

# NICE GATE&DOOR

SYSTEMS FOR THE AUTOMATION AND CONTROL OF GATES,  
GARAGE DOORS AND BARRIERS / CATALOGUE 2016





# NICE GATE&DOOR

## CATALOGO 2016

4	DESIGNING A NICE WORLD
21	LA GAMMA HI-SPEED
37	SISTEMI PER CANCELLI A BATTENTE
85	SISTEMI PER CANCELLI SCORREVOLI
107	SISTEMI ALZABARRIERA
125	SISTEMI PER PORTE DA GARAGE E INDUSTRIALI
155	SISTEMI DI COMANDO
183	ACCESSORI
211	CENTRALI DI COMANDO
225	NICE FOR YOU Servizi dedicati a te professionista per una perfetta installazione
226	GUIDA ALLA COMPATIBILITÀ DEI SISTEMI D'AUTOMAZIONE
230	INDICE ALFABETICO PER CODICE PRODOTTO

FOR INTEGRATED ALARM  
AND MANAGEMENT SYSTEMS

FOR SECTIONAL  
AND UP-AND-OVER  
GARAGE DOORS

FOR SLIDING  
AND SWING GATES

FOR LIGHTING  
SYSTEMS

FOR AWNINGS AND BLINDS,  
ROLLING SHUTTERS

# ALL IN ONE. IT'S NICE.

With Nice, all it takes is one simple movement to control and manage automations for gates, garage doors, barriers, awnings and rolling shutters, alarm and lighting systems, and electrical loads; individual, in groups or scenarios.

Wireless and solar systems make installation of any automation simple and cost effective, both in new constructions and restorations.

Just one partner that can solve all your home automation needs: Nice means the simplest integration, the most elegant design and the most advanced electronics.



2000  
"International  
Design Gallery"  
Expo 2000  
Hannover

ADI

2001  
Best of Category  
"Design for the  
Environment"  
XIX Compasso  
d'Oro



2002  
Permanent  
Collection  
at The Museum  
of Design



1999, 2003,  
2005  
"Intel Design  
Award"



1999, 2003,  
2005  
"ADI Design  
Index"



2005  
"Trophée  
d'Argent"  
Trophée  
du Design  
Batimat



2006  
"Innovation Prize"  
R+T Stuttgart



2007  
"Innovation &  
Design Award"  
LivinLuce



2008  
"Grandesign Etico  
International Award"



# FOR GATES AND DOORS? FOR YOU.

## **Ease of use, aesthetic quality, safety.**

Nice is easy to offer because it's easy to install and use, thanks to a range of products which links innovation to design:

### **1. technology for the installer**

### **2. comfort for the user**

### **3. simplicity for everyone**

Satisfy the desire of comfort and peace of mind in the most exclusive and functional way, in a perfect Nice style. Always at your side with an accurate sales and after sales service, Nice recommends you to choose the automation system that best suits your needs.

**Nice, more support, closer to you!**



## WITH JUST A CLICK

Small, slim and coloured, ideal to carry in your pocket and bag, or to use as stylish key rings; table-top or wall-mounted: the control of the entire home at your fingertips! These are the Nice radio control systems, modular, rolling code or bimodal with built-in transponder: the choice is yours!

## TOUCH SCREEN & APP

Integration of home alarm and automation systems. Era Touch is the wireless touch screen transmitter/programmer. The easiest and comfortable solution to manage up to 99 systems, individual, in groups or scenarios.

## PROXIMITY, KEY OR TOUCH SELECTORS

Practical digital, lock type selectors or proximity systems, to enter and exit the home in total safety.



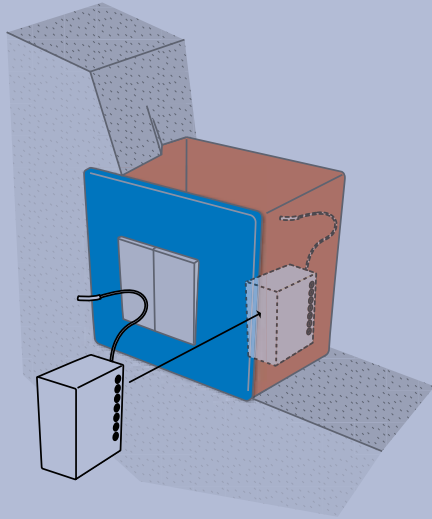

## RECESSED SYSTEMS

Nice Tag, miniaturized transmitters and control units: disappearing inside the standard wall plates, they're ideal for restorations and upgrades of existing systems, to control home automations without the need to replace the existing system or performing masonry work.

## SAFER & SAFER

A new line of accessories with a minimalist, modern and discrete design, featuring BlueBUS or all-wireless technology to guarantee safety and comfort in every residential and industrial automation application.

## AND MORE...

The most innovative automation control solutions. With Nice everything is easy: all it takes is one simple movement of the hand. New web interfaces and the possibility of integrated setups and systems... get ready for your new Nice lifestyle!

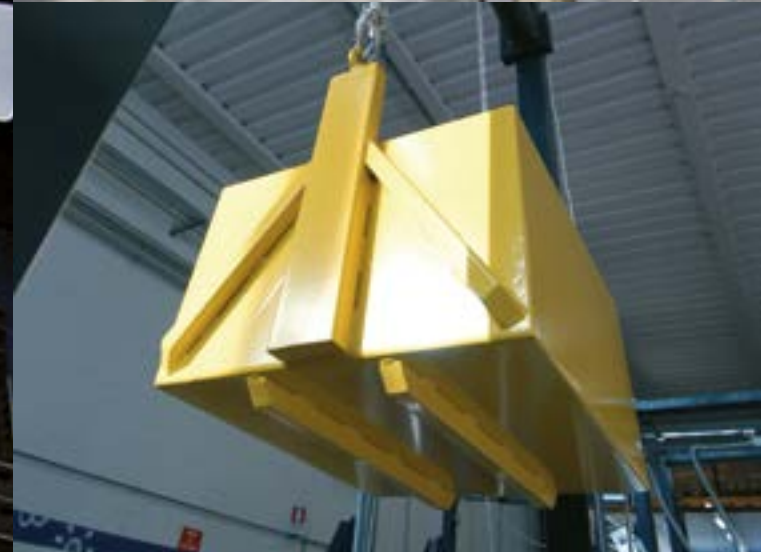
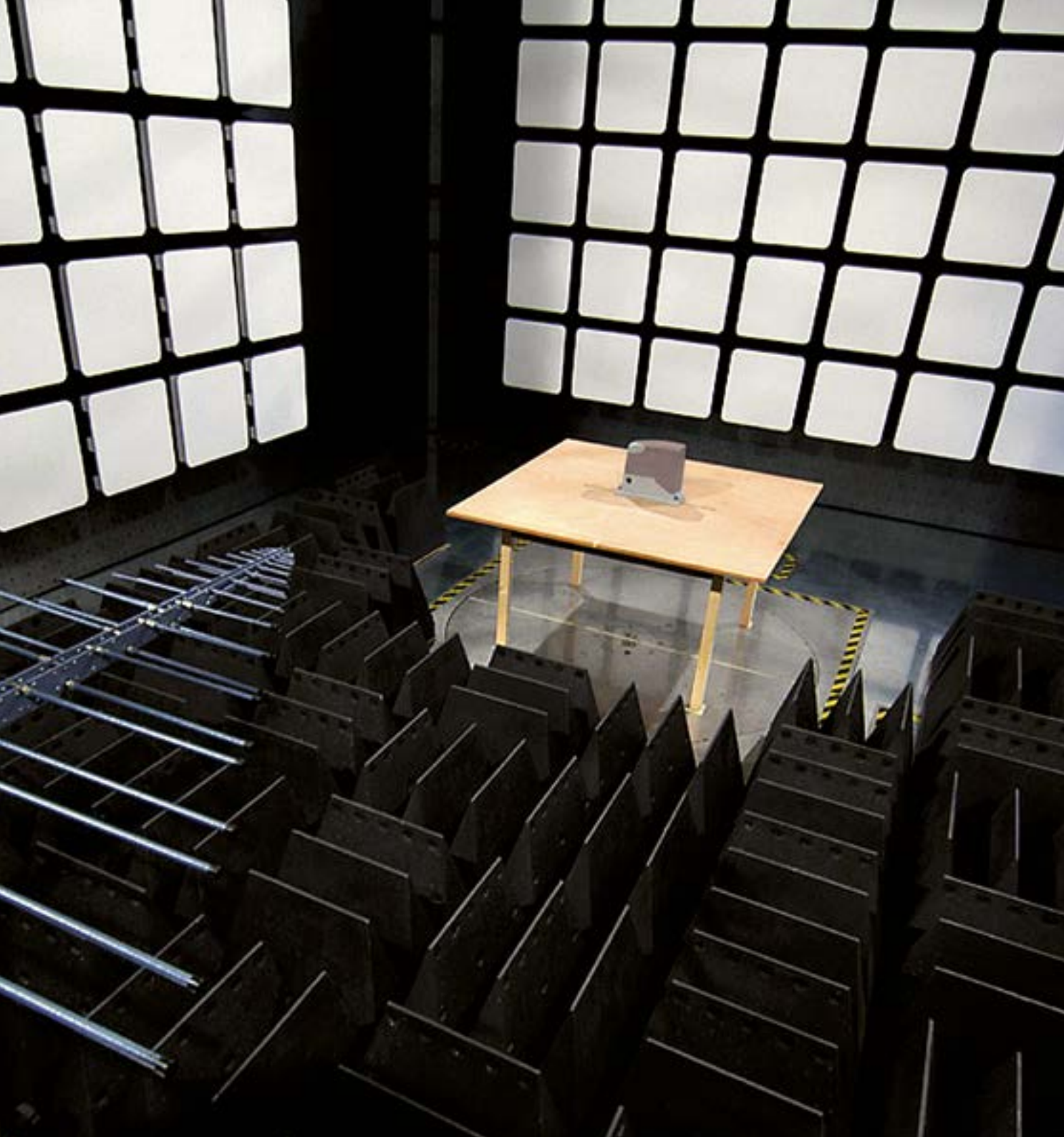

# NICE CENTRE FOR TECHNOLOGY

**Nice makes significant investments to guarantee even higher quality standards, which not only comply with directives and regulations, but also allow continuous product improvement, by exploiting high-tech procedures and experimentation and an innovative approach to open integration.**

Through its advanced laboratories Nice carefully tests and controls its products every day in order to grant safety, quality, reliability and durability over time.

Nice has adopted a quality system that complies with standard **ISO 9001**, recognized worldwide for the quality management. The laboratory also meets the strict quality requirements of **EN 17025** standards.

Nice CE certified products comply with the European Directives and the leading internationally recognized standards.

Nice laboratories have been certified by outside certification bodies, further attesting their technical expertise and conformity to carry out the tests that cover all the needs and the numerous products manufactured by the Nice group:

- LCIE (France)
- IMQ (Italy)
- Cetecom (Germany)
- FCC (USA)
- IC (Canada)
- Intertek (Sweden)
- UL (USA)



# A COMPLETE SYSTEM, WITH MANY NEW FEATURES

## HI-SPEED, FASTER THAN EVER

**High-speed 24 V motors for gate automation.**

The perfect solution to ensure the shortest waiting time and the highest safety. Versatile installation, thanks to a vast choice of solutions, precision and ensured by obstacle detection technology, long technical life, ideal for industrial applications.

**Full peace of mind, maximum convenience.**

## ERA GATE ACCESSORIES, DESIGN, VERSATILITY, COMPLETE RANGE

Three different sizes of photocells in tamper-proof and recessed versions; a complete range of selector switches, proximity readers for transponders and flashing lights to guarantee safety and comfort in every residential and industrial automation application.



## **WIDE** THE SOLID AND ESSENTIAL BARRIER GATE OPERATOR SYSTEM

24 Vdc gear motor for bars from 3 to 7 metres, with built-in control unit, adjustable speed and anti-crushing function.

**Easy to install, safe to use and simple to manage.**

## **NICE PACK** PRACTICAL AND FUNCTIONAL

Nice optimises and rationalises the use of packaging materials: more flexible and environmentally-friendly management, less waste.

**Nice for the environment and for you!**



Nice Headquarters,  
Oderzo, TV, Italy

# DESIGNING A NICE WORLD

**Improving the quality of life by simplifying everyday movements.  
Nice offers the security of going in and out in total freedom, by meeting  
the desire of comfort with practical products and an emotional design.  
In order to make the most of the housing space.**

**Nice + FontanaArte: light is movement.**

Thanks to the acquisition of FontanaArte, Nice enters the lighting system complementary sector.  
Founded in 1932 by the architect Gio Ponti, FontanaArte is one of the Italian design firms  
which has “made history in lighting and furnishings” in Italy and around the world.

**[www.fontanaarte.com](http://www.fontanaarte.com)**



# NICE PEOPLE MAKE NICE THINGS

## **TheNicePlace**

The new area covering more than 3,000 sq.m adjacent to company headquarters, devoted to meetings and the exchange, sharing and generation of knowledge, is a “living” place, open to new experiences and initiatives that respond to the needs of a company that is continuing to grow, and reflect its international nature.

With this “social hub”, Nice aims to involve people and the community in an ongoing process, so as to stimulate the development of knowledge inside and outside of the company, individually and collectively, as well as to enhance the knowledge and skills of each individual.

**[www.niceforyou.com](http://www.niceforyou.com), [www.thenicegroup.com](http://www.thenicegroup.com)**

## **Nice Feel (for everyone everywhere liberty)**

It is the project created by Nice to promote and develop activities which give people with motor difficulties greater freedom in movement and more individual autonomy.





The Nice Place,  
Oderzo, TV, Italy



# GUIDE TO READING THE CATALOGUE

1. If you know the name of the product, you can quickly find it out in the index on page 3;
2. If you know the part number but not the product name, go to pages 230/237 for the alphabetical list of part numbers;
3. If you don't know the product name or part number, look up the desired application in the index; the first few pages in each section feature a **simple selection guide** that helps identify the model of motor with the most suitable characteristics for your automation needs;

## SURFACE MOUNTED, WITH ARTICULATED ARM, RECOMMENDED FOR SMALL POSTS, IN KIT

For leaves up to 1.8 m, 24 Vdc irreversible with built-in control unit equipped with BlueBUS technology, compatible for operation with Solemyo and Opera. Mechanical limit switch on closing.

**WALKYKIT**  
pages 58/61

for 1-leaf

→ **WALKY1024KCE**

for 2-leaf

→ **WALKY2024KCE**

If you are looking to customise your automation system, refer to the compatibility table on page 226/229 to choose the most suitable electronics for each motor.



# HI-SPEED SYSTEMS FOR SLIDING GATES AND SWING GATES



SWING GATES, SURFACE MOUNTED	22	TOONA 5 HS
	24	TOONA 6 HS
	26	WINGO 3524 HS

---

SWING GATES, SURFACE MOUNTED, WITH ARTICULATED ARM	28	HYKE HS
--	----	---------

---

SWING GATES, UNDERGROUND INSTALLATION	30	M-FAB HS
--	----	----------

---

SLIDING GATES FOR RESIDENTIAL AND INDUSTRIAL APPLICATIONS	32	ROBUS 250 HS
	32	ROBUS 500 HS
	34	RUN 400 HS
	34	RUN 1200 HS

# TOONA 5 HS

NEW SOLEMYO OPERA BLUEBUS 24V

**For hi-speed automation of swing gates with leaves up to 5 m or 400 kg**, ideal for residential and industrial applications.

24 Vdc, electromechanical gear motor, surface mounted, with magnetic encoder.

 **Quick manoeuvres: 90° opening in about 16\* seconds.**

**Reliable:** the magnetic encoder ensures the safeguard of set values over time and precise obstacle detection.

**Silent:** patented layout of internal parts and lead nut in bronze.

**Sturdy:** thanks to the housing, made up of two tough aluminium shells with polyester paint finish; more resistant to atmospheric agents. Internal moving parts completely in steel, light alloys and technopolymers.

**Generously sized and practical connection compartment:** rapid and easy access from above to internal parts located in the upper section of the motor.

**Simple installation and maintenance:** with built-in capacitor.

**Moonclever control unit MC824H:**

- simple programming, by means of a single key;
- automatic memorization of limit switches on opening and closing with self-learning function;
- automatic fault diagnostics;
- programming of pause time;
- pedestrian pass door;
- deceleration on opening and closing;
- obstacle detection with dual technology;
- operation in event of power failure by means of optional rechargeable batteries (PS324);
- provision for connection of latest generation resistive sensitive edges.

\* Considering standard installation, excluding acceleration and deceleration.

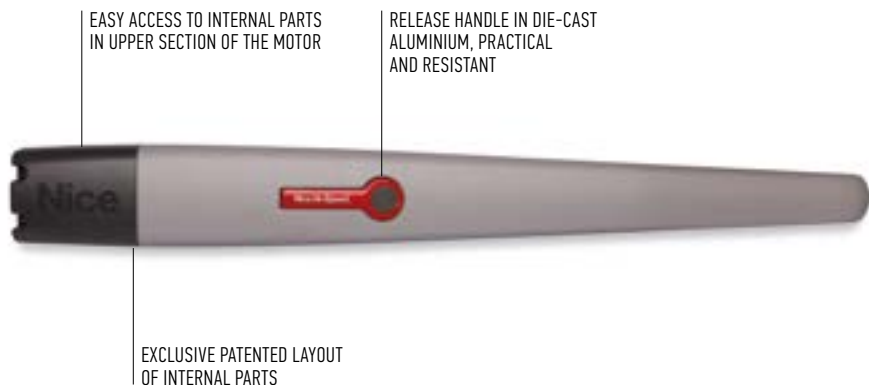

CODE	DESCRIPTION	PACK/PALLET
<b>T05024HS</b>	IRREVERSIBLE, 24 Vdc, FAST, WITH MAGNETIC ENCODER, MECHANICAL STOP ON OPENING AND CLOSING	20

## TECHNICAL SPECIFICATIONS

CODE	T05024HS
<b>ELECTRICAL DATA</b>	
POWER SUPPLY (Vdc)	24
ABSORPTION (A)	5
POWER (W)	120
<b>PERFORMANCE DATA</b>	
SPEED (m/s)	>> 0.025 <<
FORCE (N)	1800
WORK CYCLE (CYCLES/HOUR)	95
<b>DIMENSIONAL AND GENERAL DATA</b>	
PROTECTION LEVEL (IP)	44
WORKING TEMP. (°C MIN/MAX)	-20 ÷ +50
DIMENSIONS (mm)	965x115x105 h
WEIGHT (kg)	7.5

## UTILISATION LIMITS

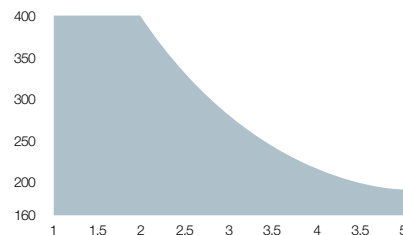

The shape, the height of the gate and the weather conditions can considerably reduce the values shown in the graph to the side. Use in windy areas 230 Vac models.

## DIMENSIONS

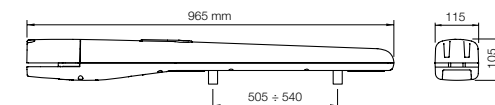

## INSTALLATION DIAGRAM

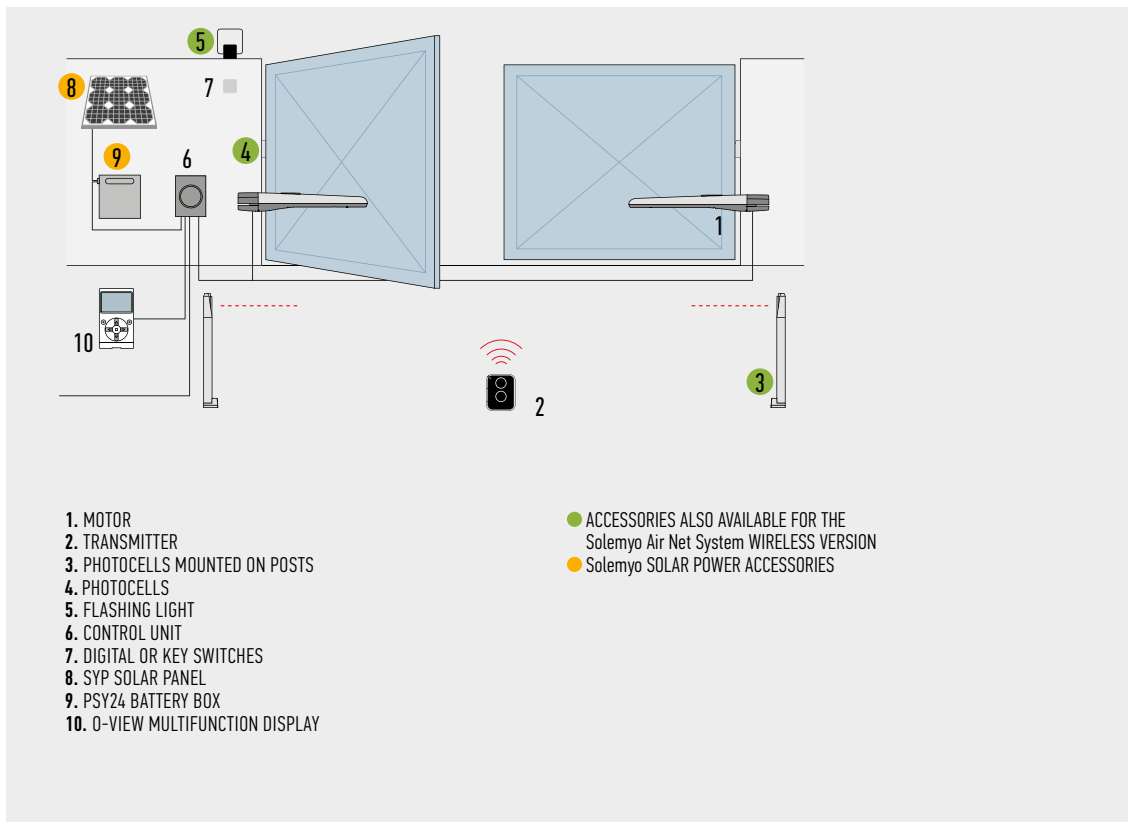

## COMPATIBILITY TABLE WITH CONTROL SYSTEMS AND ACCESSORIES

CODE	CONTROL UNIT / RECEIVER								TRANSMITTER				PHOTOCELLS								FLASHING LIGHT						
	A01 / Built-in*	A02 / Built-in*	A6F / FLOX12R*	A700F / FLOX12R*	A60 / OXI-SMX1*	A500 / FLOX12R*	A924 / FLOX12R*	MC424L / OXI	MC824H / OXI	ERA INTI	ERA ONE	ERA FLOR	NICEWAY	EPS	EPM	EPL	EP5B	EPMB	EPLB	F210	FT210	F210B	FT210B	EL	EL24	ELB	WLT
T05024HS								●	●	●	●	●															

\*Radio receiver incompatible with Opera system

## ACCESSORIES

Total interchangeability with the series Moby: identical positions and fixing brackets



**PLA6**  
 REAR BRACKET  
 250 mm LONG.  
 PC/PACK 1

**PLA8**  
 SCREW-ADJUSTABLE  
 FRONT BRACKET.  
 PC/PACK 1

**PLA10**  
 VERTICAL 12 V ELECTRIC  
 LOCK (REQUIRED FOR GATES  
 LONGER THAN 3 m).  
 PC/PACK 1

**PLA11**  
 HORIZONTAL 12 V ELECTRIC  
 LOCK (REQUIRED FOR GATES  
 LONGER THAN 3 m).  
 PC/PACK 1

### ACCESSORY

For 24 Vdc version



**TS**  
 SIGNBOARD.  
 PC/PACK 1



**PS324**  
 24 V BATTERY  
 WITH INTEGRATED  
 BATTERY CHARGER.  
 PC/PACK 1



**KIT SOLEMYO**  
 THE SOLAR POWER TO  
 AUTOMATE GATES, GARAGE  
 DOORS OR BARRIER GATES.  
 SEE PAGE 200

# TOONA 6 HS

NEW SOLEMYO OPERA BLUEBUS 24V

## For hi-speed automation of swing gates with leaves up to 6 m or 1450 kg.

24 Vdc electromechanical gear motor, surface mounted, with magnetic encoder.

### The most powerful:

ideal for industrial applications, designed for intensive use.

 **Quick manoeuvres: 90° opening in about 30\* seconds.**

**Reliable:** the magnetic encoder ensures the safeguard of set values over time and precise obstacle detection.

**Silent:** patented layout of internal parts and lead nut in bronze.

**Sturdy:** thanks to the housing, made up of two tough aluminium shells with polyester paint finish; more resistant to atmospheric agents.

Internal moving parts completely in steel, light alloys and technopolymers.

### Generously sized and practical connection compartment:

rapid and easy access from above to internal parts located in the upper section of the motor.

### Simple installation and maintenance:

with built-in capacitor.

### Moonclever control unit MC824H:

- simple programming, by means of a single key;
- automatic memorization of limit switches on opening and closing with self-learning function;
- automatic fault diagnostics;
- programming of pause time;
- pedestrian pass door;
- deceleration on opening and closing;
- obstacle detection with dual technology;
- operation in event of power failure by means of optional rechargeable batteries (PS324);
- provision for connection of latest generation resistive sensitive edges.

\* Considering standard installation, excluding acceleration and deceleration.

CODE	DESCRIPTION	PACK/PALLET
TO6024HS	IRREVERSIBLE, 24 Vdc, FAST, WITH MAGNETIC ENCODER, MECHANICAL STOP ON OPENING AND CLOSING	20

### TECHNICAL SPECIFICATIONS

CODE	TO6024HS
<b>ELECTRICAL DATA</b>	
POWER SUPPLY (Vdc)	24
ABSORPTION (A)	5
POWER (W)	120
<b>PERFORMANCE DATA</b>	
SPEED (m/s)	>> 0.016 <<
FORCE (N)	2200
WORK CYCLE (CYCLES/HOUR)	41
<b>DIMENSIONAL AND GENERAL DATA</b>	
PROTECTION LEVEL (IP)	44
WORKING TEMP. (°C MIN/MAX)	-20 ÷ +50
DIMENSIONS (mm)	1200x128x150 h
WEIGHT (kg)	15

### UTILISATION LIMITS

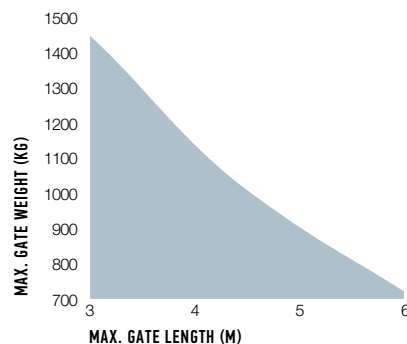

The shape, the height of the gate and the weather conditions can considerably reduce the values shown in the graph to the side. Use in windy areas 230 Vac models.

### DIMENSIONS

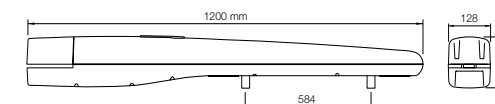

EASY ACCESS TO INTERNAL PARTS IN UPPER SECTION OF THE MOTOR

RELEASE HANDLE IN DIE-CAST ALUMINIUM, PRACTICAL AND RESISTANT

EXCLUSIVE PATENTED LAYOUT OF INTERNAL PARTS

TOUGHER HOUSING SHELL, MADE UP OF TWO STURDY SHELLS



## INSTALLATION DIAGRAM

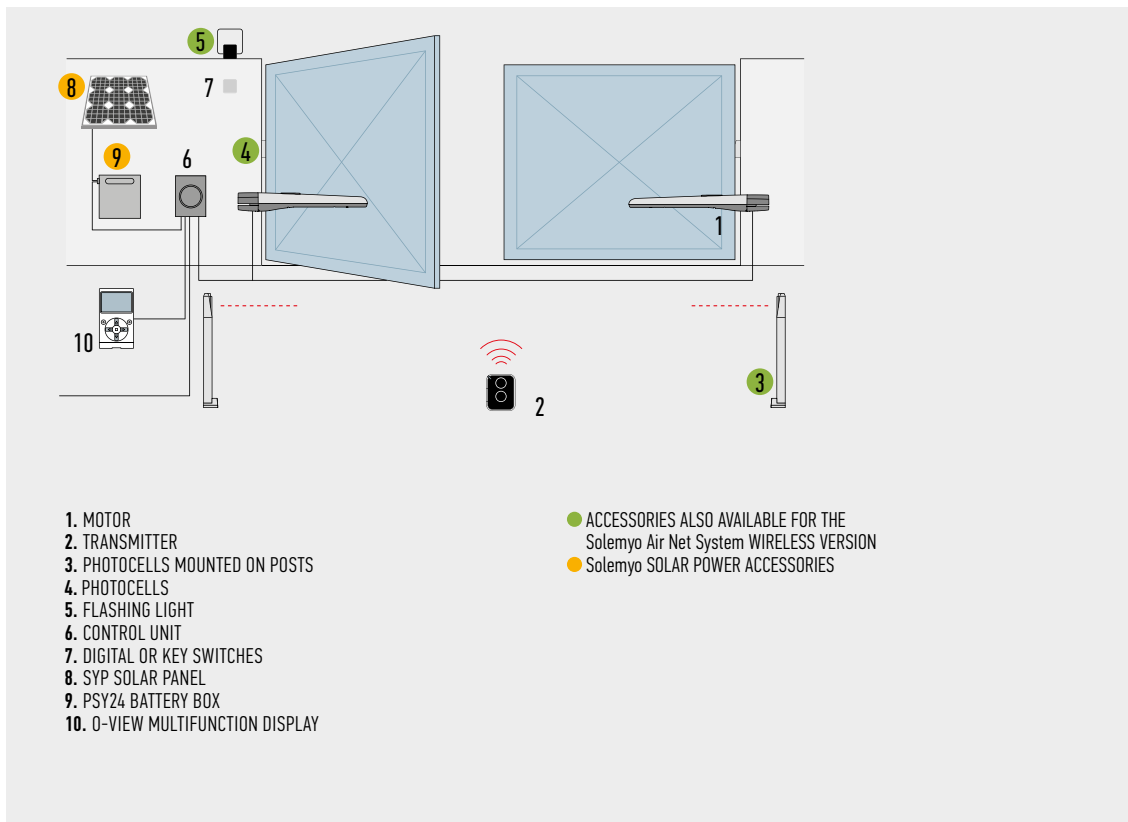

1. MOTOR
2. TRANSMITTER
3. PHOTOCELLS MOUNTED ON POSTS
4. PHOTOCELLS
5. FLASHING LIGHT
6. CONTROL UNIT
7. DIGITAL OR KEY SWITCHES
8. SYP SOLAR PANEL
9. PSY24 BATTERY BOX
10. O-VIEW MULTIFUNCTION DISPLAY

- ACCESSORIES ALSO AVAILABLE FOR THE Solemyo Air Net System WIRELESS VERSION
- Solemyo SOLAR POWER ACCESSORIES

## COMPATIBILITY TABLE WITH CONTROL SYSTEMS AND ACCESSORIES

CODE	CONTROL UNIT / RECEIVER							TRANSMITTER				PHOTOCELLS							FLASHING LIGHT								
	A01 / Built-in*	A02 / Built-in*	A6F / FLOX12R*	A700F / FLOX12R*	A60 / OXI-SMX1*	A500 / FLOX12R*	A924 / FLOX12R*	MC424L / OXI	MC824H / OXI	MC824HR / OXI	ERA INTI	ERA ONE	ERA FLOR	NICEWAY	EPS	EPM	EPL	EPSB	EPMB	EPLB	F210	FT210	F210B	FT210B	EL	EL24	ELB
<b>TO6024HS</b>								●	●	●	●	●	●				●	●	●			●			●	●	●

\*Radio receiver incompatible with Opera system

## ACCESSORIES



**PLA10**  
VERTICAL 12 V ELECTRIC LOCK (REQUIRED FOR GATES LONGER THAN 3 m).  
PC/PACK 1



**PLA11**  
HORIZONTAL 12 V ELECTRIC LOCK (REQUIRED FOR GATES LONGER THAN 3 m).  
PC/PACK 1



**TS**  
SIGNBOARD.  
PC/PACK 1



**PS324**  
24 V BATTERY WITH INTEGRATED BATTERY CHARGER.  
PC/PACK 1



**KIT SOLEMYO**  
THE SOLAR POWER TO AUTOMATE GATES, GARAGE DOORS OR BARRIER GATES. SEE PAGE 200

FOR SWING GATES  
SERIE HI-SPEED

FOR SLIDING GATES

BARRIER GATE  
OPERATOR SYSTEMS

FOR GARAGE  
AND INDUSTRIAL DOORS

CONTROL SYSTEMS  
AND ACCESSORIES

COMPATIBILITY TABLE  
AND ALPHABETICAL INDEX

# WINGO 3524 HS

NEW SOLEMYO OPERA BLUEBUS 24V

**For hi-speed automation of swing gates with leaves up to 3 m or 200 kg, ideal for residential applications.**

24 Vdc electromechanical gear motor, surface mounted, with magnetic encoder.



**Quick manoeuvres:** 90° opening in about 10\* seconds.

**Reliable:** the magnetic encoder ensures the safeguard of set values over time and precise obstacle detection.

**Silent:** patented layout of internal parts, fewer moving parts.

**Easy to install:** after the gear motor has been assembled, all electrical connections are made from above.

**Pre-assembled travel stops** on opening.

## Moonclever control unit MC824H:

- simple programming, by means of a single key;
- automatic memorization of limit switches on opening and closing with self-learning function;
- automatic fault diagnostics;
- programming of pause time;
- pedestrian pass door;
- deceleration on opening and closing;
- obstacle detection with dual technology;
- operation in event of power failure by means of optional rechargeable batteries (PS324);
- provision for connection of latest generation resistive sensitive edges.

\* Considering standard installation, excluding acceleration and deceleration.

CODE	DESCRIPTION	PACK/PALLET
WG3524HS	IRREVERSIBLE, 24 Vdc, FAST, WITH MAGNETIC ENCODER, MECHANICAL STOP ON OPENING AND CLOSING	20

## TECHNICAL SPECIFICATIONS

CODE	WG3524HS
<b>ELECTRICAL DATA</b>	
POWER SUPPLY (Vdc)	24
ABSORPTION (A)	5
POWER (W)	120
<b>PERFORMANCE DATA</b>	
SPEED (m/s)	>> 0.04 <<
FORCE (N)	1500
WORK CYCLE (CYCLES/HOUR)	30
<b>DIMENSIONAL AND GENERAL DATA</b>	
PROTECTION LEVEL (IP)	44
WORKING TEMP. (°C MIN/MAX)	-20 ÷ +50
DIMENSIONS (mm)	920x98x95 h
WEIGHT (kg)	6

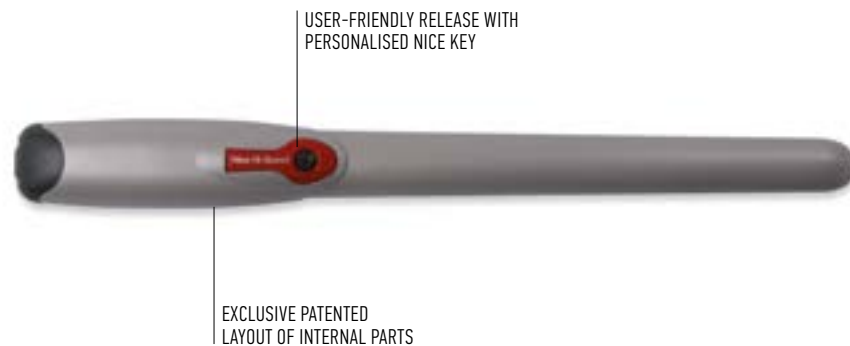

## UTILISATION LIMITS

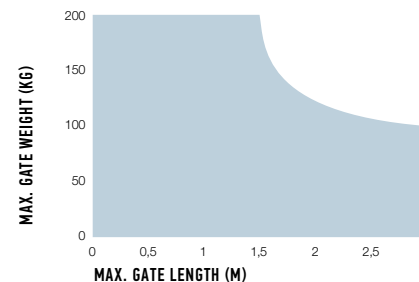

## DIMENSIONS

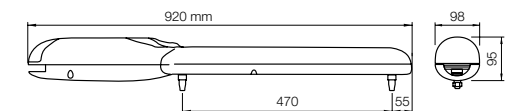

## INSTALLATION DIAGRAM

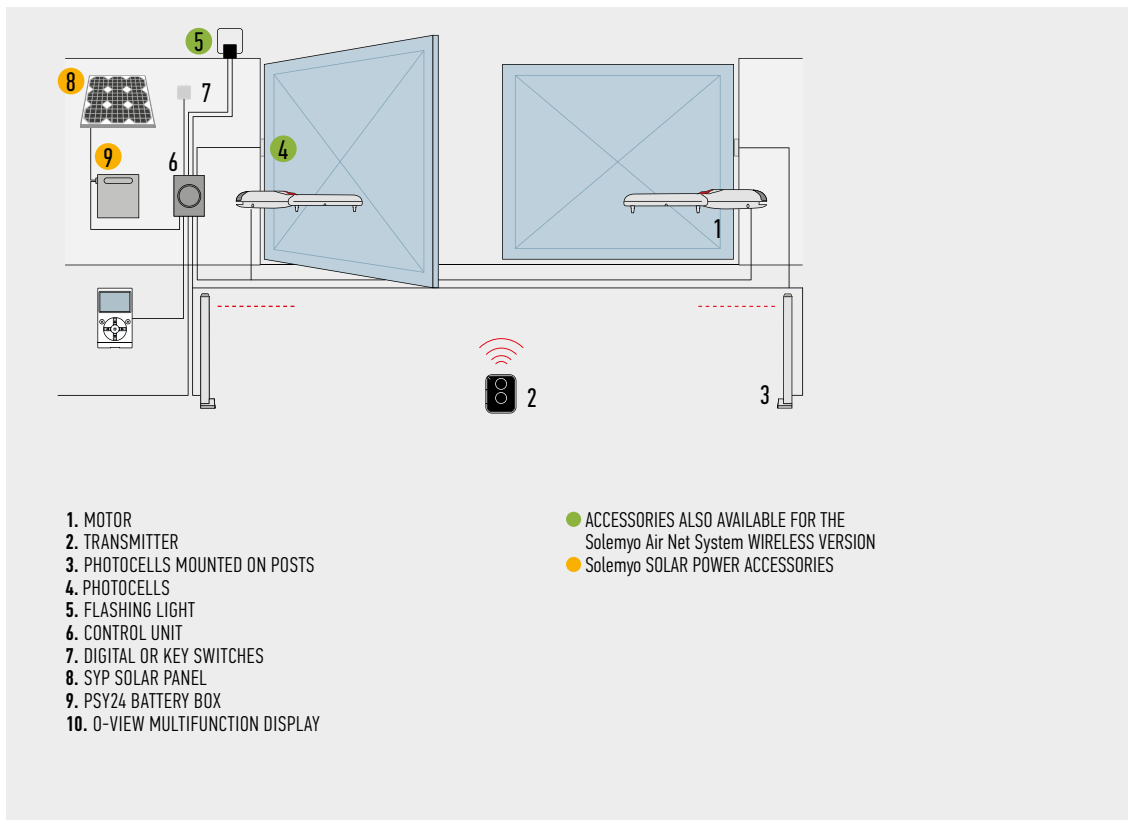

## COMPATIBILITY TABLE WITH CONTROL SYSTEMS AND ACCESSORIES

CODE	CONTROL UNIT / RECEIVER							TRANSMITTER				PHOTOCELLS							FLASHING LIGHT								
	A01 / Built-in*	A02 / Built-in*	A6F / FLOX12R*	A700F / FLOX12R*	A60 / OXI-SMX1*	A500 / FLOX12R*	A924 / FLOX12R*	MC424L / OXI	MC824H / OXI	MC824HR / OXI	ERA INTI	ERA ONE	ERA FLOR	NICEWAY	EPS	EPM	EPL	EPSB	EPMB	EPLB	F210	FT210	F210B	FT210B	EL	EL24	ELB
WG3524HS								●	●	●	●	●	●				●	●	●			●				●	●

\*Radio receiver incompatible with Opera system

## ACCESSORIES



**PS324**  
 24 V BATTERY WITH INTEGRATED BATTERY CHARGER.  
 ONLY FOR TN2010L.  
 PC/PACK 1



**PLA14**  
 SCREW-ADJUSTABLE REAR BRACKET.  
 PC/PACK 2



**PLA15**  
 SCREW-ADJUSTABLE FRONT BRACKET.  
 PC/PACK 2



**PLA10**  
 VERTICAL 12 V ELECTRIC LOCK.  
 PC/PACK 1



**PLA11**  
 HORIZONTAL 12 V ELECTRIC LOCK.  
 PC/PACK 1



**KIT SOLEMYO**  
 THE SOLAR POWER TO AUTOMATE GATES, GARAGE DOORS OR BARRIER GATES.  
 SEE PAGE 200

Nice recommends customers order products in pallets in order to facilitate storage and delivery, and ensure packs are uniform. The number of packs per single pallet has been specified for this reason. Approximate draft.

FOR SWING GATES  
SERIE HI-SPEED

FOR SLIDING GATES

BARRIER GATE  
OPERATOR SYSTEMS

FOR GARAGE  
AND INDUSTRIAL DOORS

CONTROL SYSTEMS  
AND ACCESSORIES

COMPATIBILITY TABLE  
AND ALPHABETICAL INDEX

# HYKE HS

NEW SOLEMYO OPERA 24V

**For hi-speed automation of swing gates with leaves up to 3 m or 270 kg**, ideal for residential applications even with large columns. 24 Vdc electromechanical gear motor with articulated arm, surface mounted, with magnetic encoder.

**Ideal for intensive use and quick manoeuvres: 90° opening in about 10\* seconds.**

**Ultra-powerful and reliable:** thanks to the torque of 500 Nm and encoder technology, for millimetric precision and reliability.

**Safe movement** with dual technology obstacle detection.

## Sturdy

thanks to the housing in aluminium with polyester paint finish, resistant to atmospheric agents.

**Two irreversible 24 Vdc versions** with limit switches on opening and closing: with built-in control unit (HK7024) and without control unit (HK7224).

**Practical and quick installation:** the articulated arm is adjustable in length for maximum flexibility.

**Simple and precise limit switch adjustment:** mechanical stops and micrometric adjustment screws.

**No black out:** with the optional batteries (PS124) housed inside the gear motor.

## Built-in control unit (HK7024):

- simple programming via a single key;
- self-learning of opening and closing limit positions;
- automatic fault diagnostics;
- pause time programming;
- pedestrian pass door;
- deceleration on opening and closing;
- obstacle detection with dual technology;
- provision for connection of latest generation sensitive edges.



Adjustable anti-crushing arm



CODE	DESCRIPTION	PACK/PALLET
HK7024HS	IRREVERSIBLE 24 Vdc, FAST, WITH MAGNETIC ENCODER, COMPLETE WITH ARTICULATED ARM AND BUILT-IN CONTROL UNIT	12
HK7224HS	IRREVERSIBLE 24 Vdc, FAST, COMPLETE WITH ARTICULATED ARM WITHOUT CONTROL UNIT	12

## TECHNICAL SPECIFICATIONS

CODE	HK7024HS	HK7224HS
<b>ELECTRICAL DATA</b>		
POWER SUPPLY (Vac 50/60HZ)	230	-
POWER SUPPLY (Vdc)	-	24
ABSORPTION (A)	1.5	6
POWER (W)	300	140
<b>PERFORMANCE DATA</b>		
SPEED (rpm)	>> 2 <<	
TORQUE (Nm)	500	
WORK CYCLE (CYCLES/HOUR)	40	
<b>DIMENSIONAL AND GENERAL DATA</b>		
PROTECTION LEVEL (IP)	54	
WORKING TEMP. (°C MIN/MAX)	-20 ÷ +50	
DIMENSIONS (mm)	290x210x320 h	
WEIGHT (kg)	10.5	9.5

## UTILISATION LIMITS

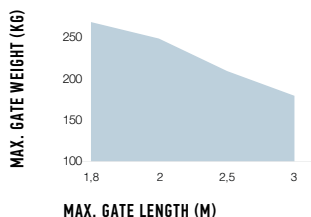
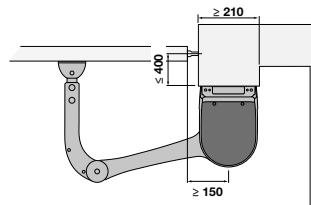

The shape, the height of the gate and the weather conditions can considerably reduce the values shown in the graph to the side.

## DIMENSIONS

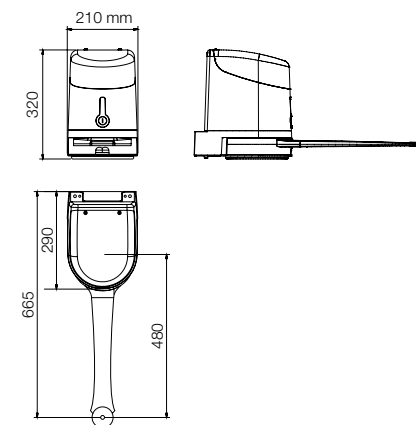

## INSTALLATION DIAGRAM

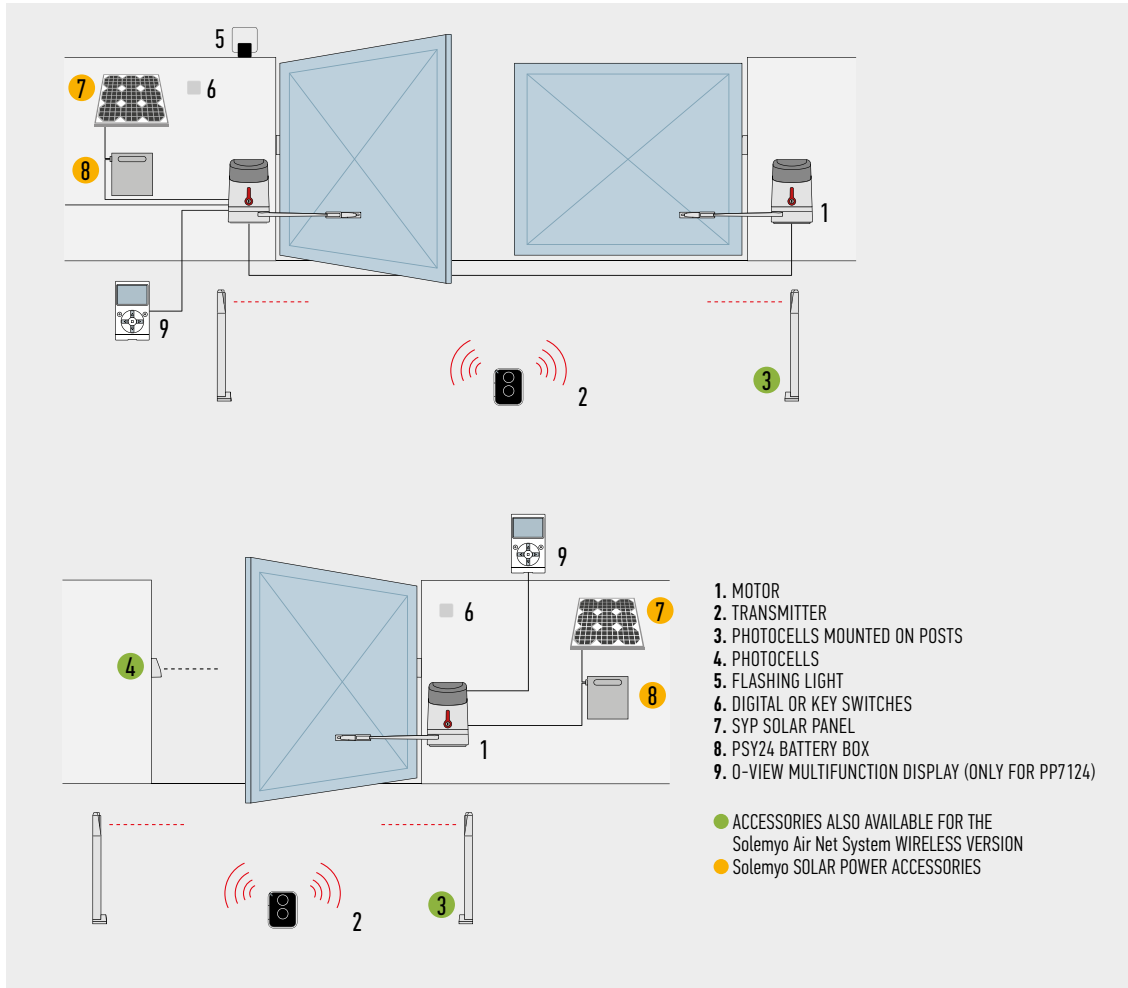

## COMPATIBILITY TABLE WITH CONTROL SYSTEMS AND ACCESSORIES

CODE	RECEIVER		TRANSMITTER				PHOTOCELLS								FLASHING LIGHT						
	Built-in*	FLOXIZR*	OXI	ERA INTI	ERA ONE	ERA FLOR	NICEWAY	EPS	EPM	EPL	EPSB	EPMB	EPLB	F210	FT210	F210B	FT210B	EL	EL24	ELB	WLT
HK7024HS			●	●	●	●	●				●	●	●			●				●	●

\*Radio receiver incompatible with Opera system

## ACCESSORIES



**HKA2**  
SPARE CONTROL UNIT FOR HK7024HS.



**PS124**  
24 V BATTERY WITH INTEGRATED BATTERY CHARGER.  
PC/PACK 1



**PLA10**  
VERTICAL 12 V ELECTRIC LOCK (REQUIRED FOR GATES LONGER THAN 3 m).  
PC/PACK 1



**PLA11**  
HORIZONTAL 12 V ELECTRIC LOCK (REQUIRED FOR GATES LONGER THAN 3 m).  
PC/PACK 1



**KIO**  
KEY-OPERATED SELECTOR SWITCH FOR LOW VOLTAGE CONTACTS, WITH RELEASE MECHANISM FOR METAL CORD.  
PC/PACK 1



**KA1**  
6 m CABLE RELEASE KIT FOR KIO.  
PC/PACK 1



**TS**  
SIGNBOARD.  
PC/PACK 1



**KIT SOLEMYO**  
THE SOLAR POWER TO AUTOMATE GATES, GARAGE DOORS OR BARRIER GATES. SEE PAGE 200

FOR SWING GATES  
SERIE HI-SPEED

FOR SLIDING GATES

BARRIER GATE  
OPERATOR SYSTEMS

FOR GARAGE  
AND INDUSTRIAL DOORS

CONTROL SYSTEMS  
AND ACCESSORIES

COMPATIBILITY TABLE  
AND ALPHABETICAL INDEX

# M-FAB HS

NEW SOLEMYO OPERA BLUEBUS 24V

For hi-speed automation of swing gates with leaves up to 3 m or 300 kg, underground installation, ideal for residential applications.

24 Vdc electromechanical gear motor, with magnetic encoder.

**Ideal for intensive use and quick manoeuvres: 90° opening in about 8 seconds.**

Foundation boxes externally chamfered, Fab Box with mechanical stop on opening:

- in stainless steel (XFABBOXI), ideal for use in extreme conditions,
- with the cataphoresis paint finish (MFABBOX), highly resistant to corrosion.

**Reliable and resistant:** motors made up of solid internal parts in metal. New IP67 waterproof die cast aluminium.

**Total freedom of choice:** release from inside and outside, two key-operated models or freely compatible lever version and easily activated with just one hand.

**Simple to use:** mechanical stop system on closure. Standard opening max. 110°, optional opening 360°.

**Totally compatible** with the previous Metro series.

**Moonclever MC824H control unit:**

- simple programming, by means of a single key;
- self-learning of opening and closing limit positions;
- automatic fault diagnostics;
- programming of pause time;
- pedestrian pass door;
- deceleration on opening and closing;
- obstacle detection with dual technology;
- operation in event of power failure by means of optional rechargeable batteries (PS324);
- provision for connection of latest generation resistive sensitive edges.

EVEN MORE RELIABLE AND RESISTENT



WATERPROOF, WITH IP67 PROTECTION RATING

EXTERNALLY CHAMFERED FAB BOX

CODE	DESCRIPTION	PACK/PALLET
MFAB3024HS	IRREVERSIBLE 24 Vdc, FAST, WITH MAGNETIC ENCODER, COMPLETE WITH CONNECTING LEVER AND MECHANICAL STOP FOR THE CLOSING MANOEUVRE	18

CODE	DESCRIPTION	PACK/PALLET
XFABBOXI	EXTERNALLY CHAMFERED FOUNDATION BOX IN STAINLESS STEEL WITH MECHANICAL STOP ON OPENING	20
MFABBOX	EXTERNALLY CHAMFERED FOUNDATION BOX WITH CATAPHORESIS FINISH WITH MECHANICAL STOP ON OPENING	20

**NOTE:** key release mechanism, freely compatible with selection of models MEA2 and MEA3 motor.

## TECHNICAL SPECIFICATIONS

CODE	MFAB3024HS
<b>ELECTRICAL DATA</b>	
POWER SUPPLY (Vdc)	24
ABSORPTION (A)	6
POWER (W)	170
<b>PERFORMANCE DATA</b>	
SPEED (rpm)	>> 2.6 <<
TORQUE (Nm)	180
WORK CYCLE (CYCLES/HOUR)	80
<b>DIMENSIONAL AND GENERAL DATA</b>	
PROTECTION LEVEL (IP)	67
WORKING TEMP. (°C MIN/MAX)	-20 ÷ +50
DIMENSIONS (mm)	390x322x194 h
WEIGHT (kg)	11

## UTILISATION LIMITS

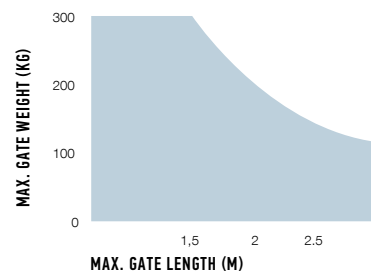

The shape, the height of the gate and the weather conditions can considerably reduce the values shown in the graph to the side.

## DIMENSIONS

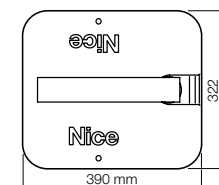
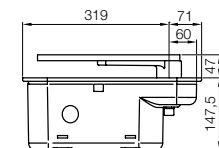

## INSTALLATION DIAGRAM

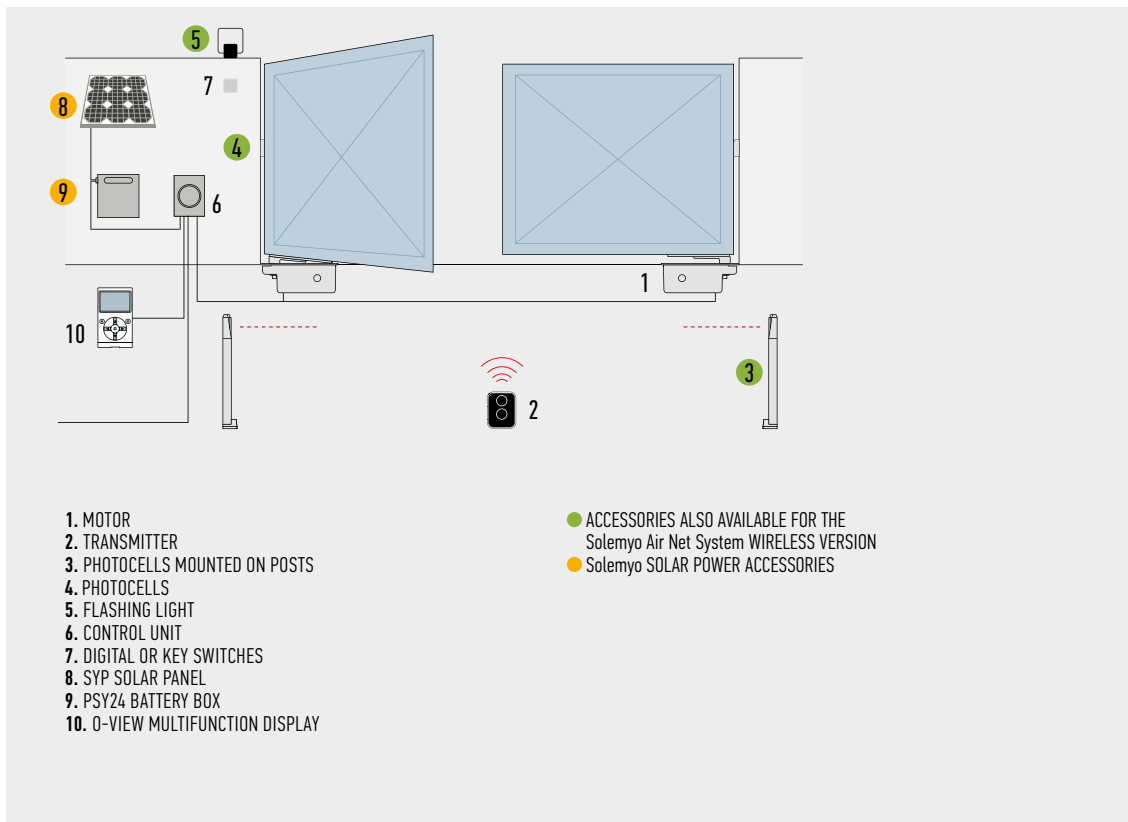

## COMPATIBILITY TABLE WITH CONTROL SYSTEMS AND ACCESSORIES

CODE	CONTROL UNIT / RECEIVER								TRANSMITTER				PHOTOCELLS							FLASHING LIGHT						
	A01 / Built-in*	A02 / Built-in*	A6F / FLOX12R*	A700F / FLOX12R*	A60 / OX1-SMX1*	A500 / FLOX12R*	A924 / FLOX12R*	MC424L / OXI	MC824H / OXI	ERA INTI	ERA ONE	ERA FLOR	NICEWAY	EPS	EPM	EPL	EPSB	EPMB	EPLB	F210	FT210	F210B	FT210B	EL	EL24	ELB
MFAB3024HS					●				●	●	●	●				●	●	●			●			●	●	●

\*Radio receiver incompatible with Opera system

## ACCESSORIES

**ME2**  
KEY UNLOCK SYSTEM.  
PC/PACK 1

**ME3**  
LEVER-TYPE KEY UNLOCK SYSTEM TO USE WHEN SYSTEM IS INSTALLED ON SURFACES SUCH AS SAND OR EARTH.  
PC/PACK 1

**ME5**  
LEVER-TYPE UNLOCK KEY FOR MEA3.  
PC/PACK 4

**ME6**  
LIMIT SWITCH BRACKET, FOR INSTALLATIONS WHERE BOX EMBEDDING IN CONCRETE IS NOT POSSIBLE.  
PC/PACK 1

**ME1**  
ACCESSORY FOR OPENING UP TO 360° FOR GATES MAX. 2.5 m IN LENGTH.  
PC/PACK 1

**PLA10**  
VERTICAL 12 V ELECTRIC LOCK.  
PC/PACK 1

**PLA11**  
HORIZONTAL 12 V ELECTRIC LOCK.  
PC/PACK 1

**TS**  
SIGNBOARD.  
PC/PACK 1

## ACCESSORY

For 24 Vdc version

**PS324**  
24 V BATTERY WITH INTEGRATED BATTERY CHARGER.  
PC/PACK 1

**KIT SOLEMYO**  
THE SOLAR POWER TO AUTOMATE GATES, GARAGE DOORS OR BARRIER GATES. SEE PAGE 200

FOR SWING GATES SERIE HI-SPEED  
FOR SLIDING GATES  
BARRIER GATE OPERATOR SYSTEMS  
FOR GARAGE AND INDUSTRIAL DOORS  
CONTROL SYSTEMS AND ACCESSORIES  
COMPATIBILITY TABLE AND ALPHABETICAL INDEX

Nice recommends customers order products in pallets in order to facilitate storage and delivery, and ensure packs are uniform. The number of packs per single pallet has been specified for this reason. Approximate draft.

# ROBUS 250/500 HS

NEW SOLEMYO OPERA BLUEBUS 24V

**For hi-speed automation of sliding gates weighing up to 250 kg (RB250HS) and up to 500 kg (RB500HS), for residential and industrial applications.**  
24 Vdc electromechanical gear motor.

 **Ideal for intensive use, opening a 4 m gate takes around 10\* seconds with RB250HS and around 9\* seconds with RB500HS.**

**User-friendly:** thanks to the Nice BlueBUS technology, the control unit can be connected to up to seven couples of photocells, control, security and signalling devices, using two wires only.

**Practical:** the control unit and PS124 buffer battery (optional) can be connected by means of a simple connector and can be housed directly inside Robus.

**Advanced:** the temperature sensor adapts the motor power to the climatic conditions and at the same time thermal cut-out.

A master/slave selection automatically synchronises two motors. This means it is possible to automate 2-leaf sliding gates set opposite each other.

**Intelligent:** thanks to the obstacle detection system and automatic programming of the working times. Self-diagnosis by means of a flashing light. 8 programming levels.

**Safe:** acceleration and deceleration can be adjusted at the beginning and at the end of each opening and closing manoeuvre.

**Sturdy:** base and release in pressure die cast with easy to open handle.

**Very quiet:** gear motor on bearings.

\* Considering standard installation, excluding acceleration and deceleration.



COMPARTMENT FOR CONTROL UNIT PROTECTED BY REMOVABLE BOX

PRESSURE DIE-CAST ALUMINIUM BASE AND RELEASE, WITH EPOXY PAINTING

CODE	DESCRIPTION	PACK/PALLET
<b>RB250HS</b>	IRREVERSIBLE, 24 Vdc, FAST, WITH INCORPORATED CONTROL UNIT, WITH ELECTROMECHANICAL LIMIT SWITCH, FOR GATES UP TO 250 kg	14
<b>RB500HS</b>	IRREVERSIBLE, 24 Vdc, FAST, WITH INCORPORATED CONTROL UNIT, WITH ELECTROMECHANICAL LIMIT SWITCH, FOR GATES UP TO 500 kg	14

## TECHNICAL SPECIFICATIONS

CODE	RB250HS	RB500HS
<b>ELECTRICAL DATA</b>		
POWER SUPPLY (Vac 50/60 Hz)	230	230
ABSORPTION (A)	2.1	2.2
POWER (W)	430	450
<b>PERFORMANCE DATA</b>		
SPEED (m/s)	>> 0.4 <<	>> 0.44 <<
TORQUE (Nm)	310	360
WORK CYCLE (CYCLES/HOUR)	50	20
<b>DIMENSIONAL AND GENERAL DATA</b>		
PROTECTION LEVEL (IP)	44	
WORKING TEMP. (°C MIN/MAX)	-20 ÷ +50	
DIMENSIONS (mm)	330x195x277 h	330x210x303 h
WEIGHT (kg)	8	11

## DIMENSIONS

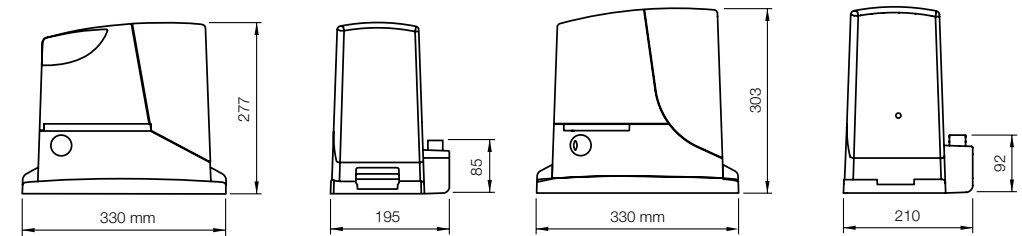

**RB250**

**RB500**



## INSTALLATION DIAGRAM

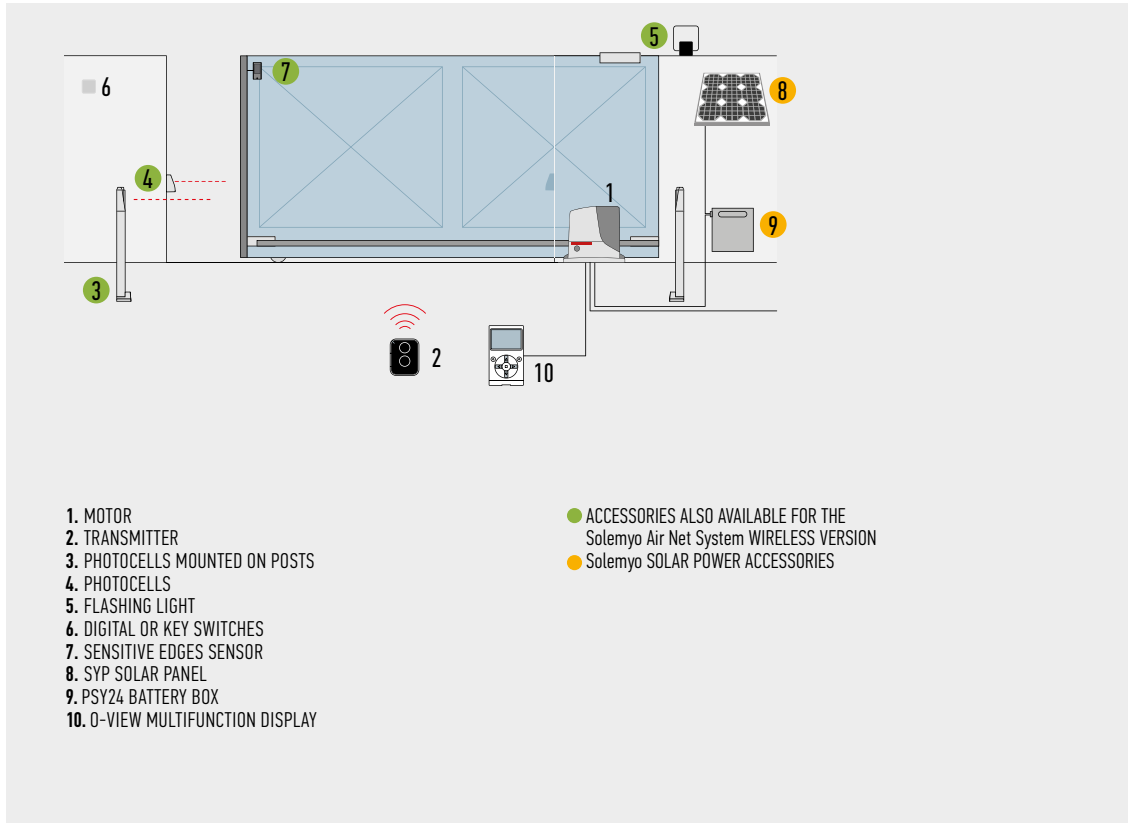

## COMPATIBILITY TABLE WITH CONTROL SYSTEMS AND ACCESSORIES

CODE	RECEIVER		TRANSMITTER				PHOTOCELLS						FLASHING LIGHT								
	Built-in*	FLOX12R*	OXI	ERA INTI	ERA ONE	ERA FLOR	NICEWAY	EPS	EPM	EPL	EPSB	EPMB	EPLB	F210	FT210	F210B	F7210B	EL	EL24	ELB	WLT
<b>RB250HS</b>			●	●	●	●	●				●	●	●			●	●			●	●
<b>RB500HS</b>			●	●	●	●	●				●	●	●			●	●			●	●

\*Radio receiver incompatible with Opera system

## ACCESSORIES



**RBA3/HS**  
SPARE CONTROL UNIT FOR RB250HS AND RB500HS.  
PC/PACK 1



**PS124**  
24 V BATTERY WITH INTEGRATED BATTERY CHARGER.  
PC/PACK 1



**RBA1**  
INDUCTIVE LIMIT SWITCH.  
PC/PACK 1



**ROA6**  
(FOR RB400)  
M4 25x20x1000 mm SLOTTED NYLON RACK WITH METAL INSERT FOR GATES WEIGHING UP TO 500 kg.  
PC/PACK 10



**ROA7**  
M4 RACK, ZINC COATED, 22x22x1000 mm.  
PC/PACK 10



**ROA8**  
M4 RACK, 30x8x1000 mm, ZINC COATED WITH SPACERS AND SCREWS.  
PC/PACK 10



**TS**  
SIGNBOARD.  
PC/PACK 1



**KIT SOLEMYO**  
THE SOLAR POWER TO AUTOMATE GATES, GARAGE DOORS OR BARRIER GATES. SEE PAGE 200

FOR SWING GATES

FOR SLIDING GATES HI-SPEED SERIES

BARRIER GATE OPERATOR SYSTEMS

FOR GARAGE AND INDUSTRIAL DOORS

CONTROL SYSTEMS AND ACCESSORIES

COMPATIBILITY TABLE AND ALPHABETICAL INDEX

# RUN 400/1200 HS

NEW OPERA BLUEBUS 24V

**For hi-speed automation of sliding gates weighing up to 400 kg (RUN400HS) and up to 1200 kg (RUN1200HS), for residential and industrial applications.**

24 Vdc electromechanical gear motor.

**The fastest:** ideal for industrial applications, designed for intensive use.



**Rapid manoeuvres, with opening and closing;**

opening a 4 m gate takes around 6\* seconds with RUN400HS, while opening a 7 m gate takes around 18\* seconds with RUN1200HS.

**User-friendly:** thanks to the Nice BlueBUS technology, the control unit can be connected to up to seven couples of photocells, control, security and signalling devices, using two wires only.

**Practical:** the control unit and PS524 battery charger (to which two B12-B batteries should be added) can be connected by means of a simple connector and can be housed directly inside the motor.

**Advanced:** the temperature sensor adapts the motor power to the climatic conditions and at the same time thermal cut-out. A master/slave selection automatically synchronises two motors. This means it is possible to automate 2-leaf sliding gates set opposite each other.

**Intelligent:** thanks to the obstacle detection system and automatic programming of the working times. Self-diagnosis by means of a flashing light. 8 programming levels.

**Safe:** acceleration and deceleration can be adjusted at the beginning and at the end of each opening and closing manoeuvre.

**Sturdy:** base and release in pressure die cast with easy to open handle.

**Very quiet:** gear motor on bearings.

\* Considering standard installation, excluding acceleration and deceleration.

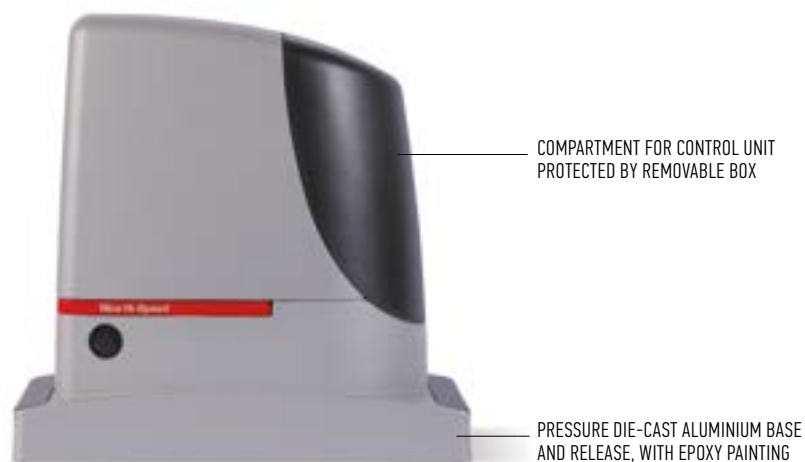

CODE	DESCRIPTION	PACK/PALLET
RUN400HS	IRREVERSIBLE, 24 Vdc, FAST, WITH INCORPORATED CONTROL UNIT, WITH ELECTROMECHANICAL LIMIT SWITCH, FOR GATES UP TO 400 kg	12
RUN1200HS	IRREVERSIBLE, 24 Vdc, FAST, WITH INCORPORATED CONTROL UNIT, WITH ELECTROMECHANICAL LIMIT SWITCH, FOR GATES UP TO 1200 kg	12

## TECHNICAL SPECIFICATIONS

CODE	RUN400HS	RUN1200HS
<b>ELECTRICAL DATA</b>		
POWER SUPPLY (Vac 50/60 Hz)	230	230
ABSORPTION (A)	2	2
POWER (W)	415	415
<b>PERFORMANCE DATA</b>		
SPEED (m/s)	>> 0.7 <<	>> 0.37 <<
TORQUE (Nm)	409	790
WORK CYCLE (CYCLES/HOUR)	60	60
<b>DIMENSIONAL AND GENERAL DATA</b>		
PROTECTION LEVEL (IP)	44	
WORKING TEMP. (°C MIN/MAX)	-20 ÷ +50	
DIMENSIONS (mm)	400x255x387 h	
WEIGHT (kg)	24.5	

## DIMENSIONS

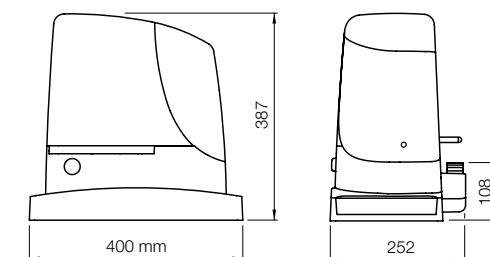

## INSTALLATION DIAGRAM

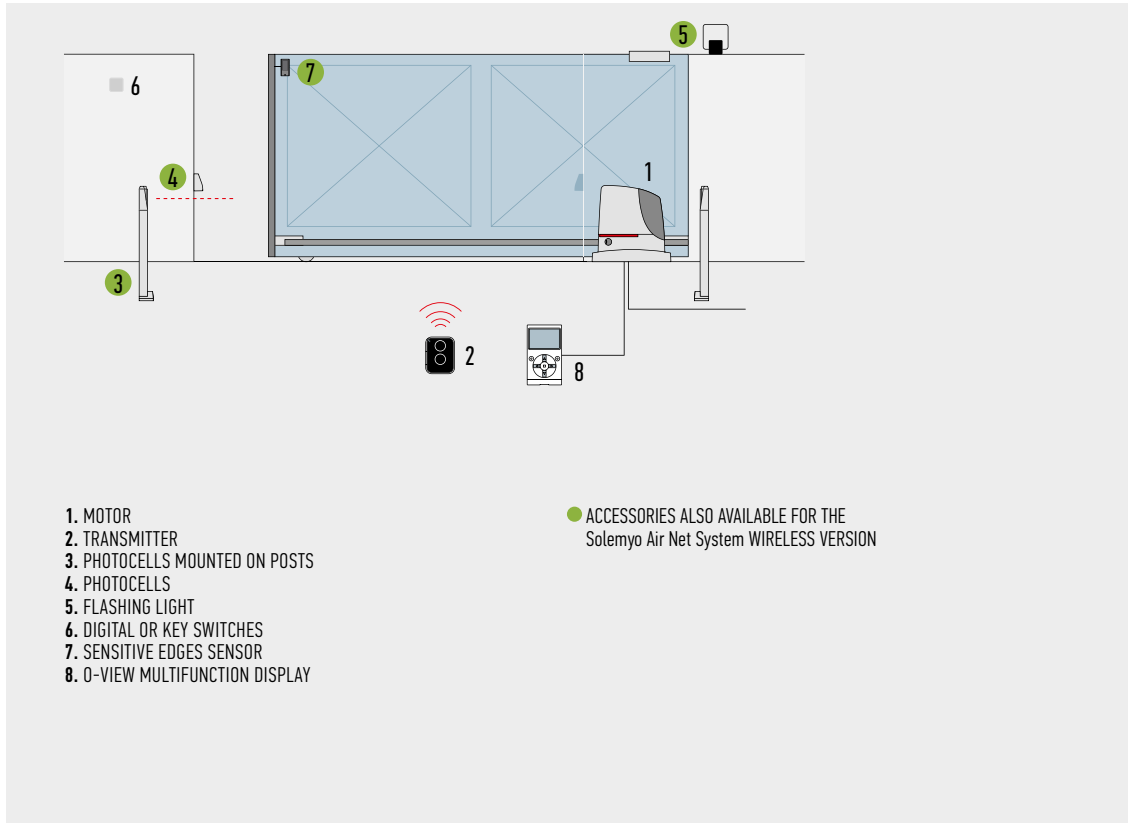

## COMPATIBILITY TABLE WITH CONTROL SYSTEMS AND ACCESSORIES

CODE	RECEIVER		TRANSMITTER				PHOTOCELLS							FLASHING LIGHT							
	Built-in*	FLOX12R*	OXI	ERA INTI	ERA ONE	ERA FLOR	NICEWAY	EPS	EPM	EPL	EPSB	EPMB	EPLB	F210	FT210	F210B	FT210B	EL	EL24	ELB	WLT
RUN400HS			●	●	●	●	●				●	●	●			●	●			●	●
RUN1200HS			●	●	●	●	●				●	●	●			●	●			●	●

\*Radio receiver incompatible with Opera system

## ACCESSORIES



**RUA6**  
 SPARE CONTROL UNIT  
 FOR RUN400HS AND  
 RUN1200HS.  
 PC/PACK 1



**B12-B**  
 12 V, 6 Ah BATTERIES.  
 PC/PACK 1



**PS524**  
 CHARGE CARD  
 FOR 7 Ah BATTERIES.  
 PC/PACK 1



**RBA1**  
 INDUCTIVE LIMIT SWITCH.  
 PC/PACK 1



**ROA7**  
 M4 RACK, ZINC COATED,  
 22X22X1000 mm.  
 PC/PACK 10



**ROA8**  
 M4 RACK, 30X8X1000 mm,  
 ZINC COATED WITH SPACERS  
 AND SCREWS.  
 PC/PACK 10



**ROA81**  
 M6 RACK, 30X30X1000 mm,  
 ZINC COATED, TO BE  
 COUPLED WITH RUA12.  
 PC/PACK 1



**RUA12**  
 12-TEETH PINION,  
 MODULE 6, TO BE COUPLED  
 WITH RACK ROA81.  
 The Run automation is supplied  
 with a module 4 pinion to be used  
 with the standard racks ROA7  
 and ROA8.  
 PC/PACK 1



**TS**  
 SIGNBOARD.  
 PC/PACK 1

FOR SWING GATES

FOR SLIDING GATES  
 HI-SPEED SERIES

BARRIER GATE  
 OPERATOR SYSTEMS

FOR GARAGE  
 AND INDUSTRIAL DOORS

CONTROL SYSTEMS  
 AND ACCESSORIES

COMPATIBILITY TABLE  
 AND ALPHABETICAL INDEX



# SYSTEMS FOR SWING GATES



SURFACE MOUNTED	42	TOONA 4
	44	TOONA 5
	46	TOONA 7
	48	TOONAKIT
	50	WINGOKIT
	52	WINGOKIT 4024
	54	WINGO5KIT
	56	WINGOKIT 5024

---

SURFACE MOUNTED, WITH ARTICULATED ARM	58	WALKYKIT 1024
	60	WALKYKIT 2024
	62	HOPP
	64	HOPPKIT
	66	HYKE
	68	HYKEKIT
	70	HYPPO 7000

---

UNDERGROUND INSTALLATION	72	X-FAB
	74	X-FABKIT 2024
	76	X-FABKIT 2124
	78	M-FAB
	80	L-FAB
	82	BIG-FAB

# SELECTION GUIDE

SURFACE MOUNTED, ALSO AVAILABLE IN KIT

**TOONA HS**  
pages 22/25



**TOONA, TOONAKIT**  
pages 42/49

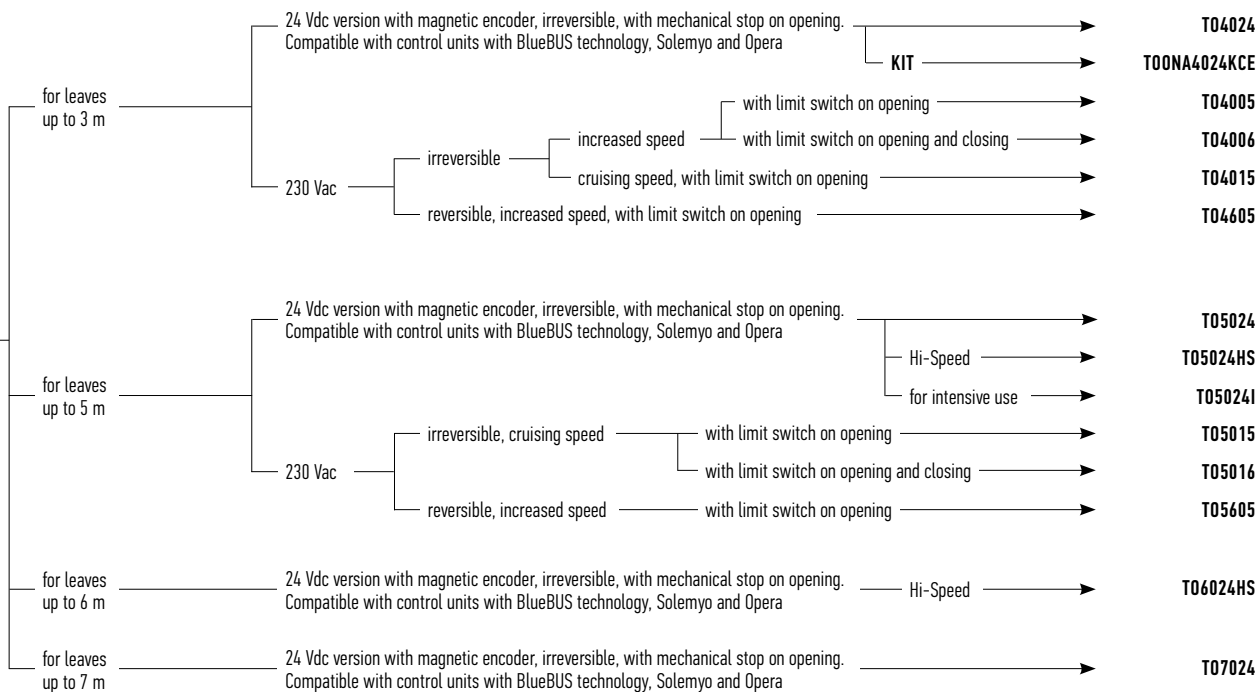

**WINGO HS**  
pages 26/27



**WINGOKIT**  
pages 50/57

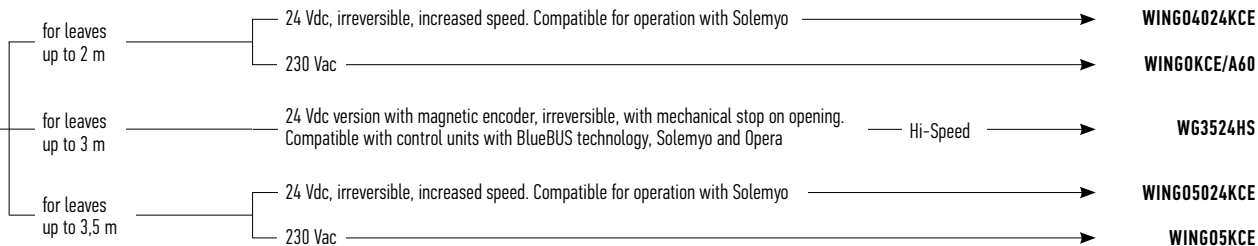

**SURFACE MOUNTED, WITH ARTICULATED ARM, RECOMMENDED FOR SMALL POSTS, IN KIT**

For leaves up to 1.8 m, 24 Vdc irreversible with built-in control unit equipped with BlueBUS technology, compatible for operation with Solemyo and Opera. Mechanical limit switch on closing.  
**WALKYKIT**  
 pages 58/61

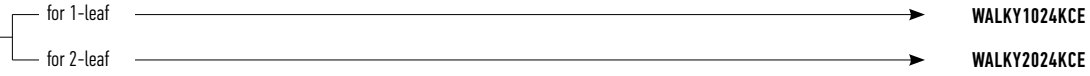

**SURFACE MOUNTED, ARTICULATED ARM, ALSO FOR LARGE SIZE POSTS AND LIGHTWEIGHT STRUCTURES, ALSO AVAILABLE IN KIT**

For leaves up to 2.4 m, 24 Vdc, reversible. Control units compatible with Solemyo. With limit switch on opening.  
**HOPP**  
**HOPPKIT**  
 pages 62/65

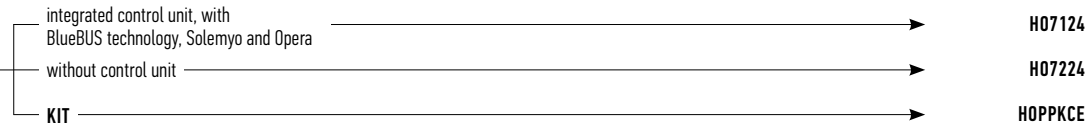

# SELECTION GUIDE

## SURFACE MOUNTED, ARTICULATED ARM, FOR LARGE SIZE POSTS

**HYKE HS**  
pages 28/29



**HYKE, HYKEKIT**  
pages 66/69

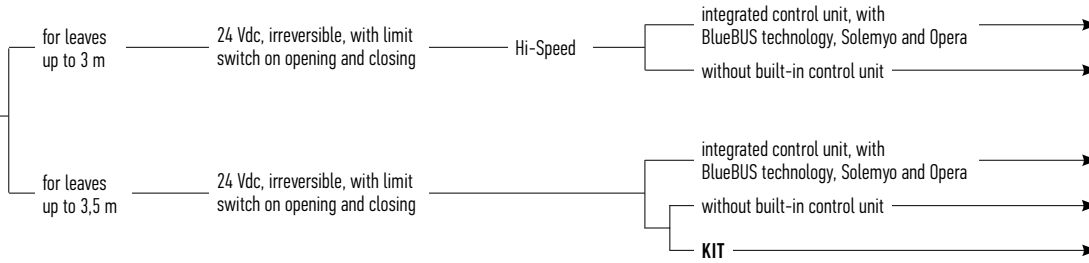

For leaves up to 3 m, irreversible.  
**HYPPO**  
pages 70/71

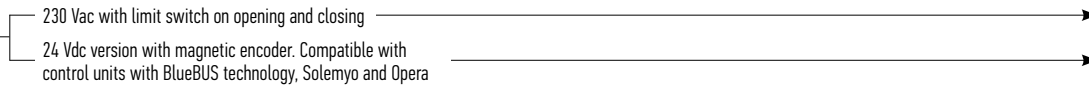

## UNDERGROUND INSTALLATION

For leaves up to 2,3 m, 24 Vdc irreversible, mechanical limit switches on opening and closing.  
**X-FAB**  
**X-FABKIT**  
pages 72/77

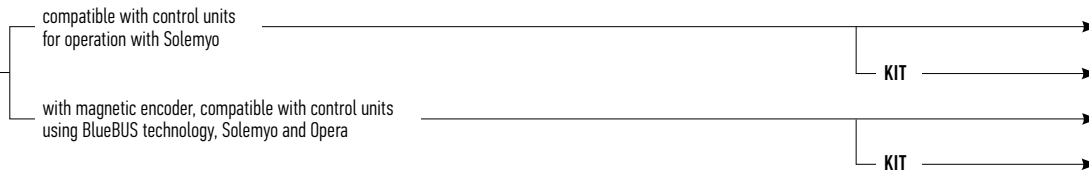



**UNDERGROUND INSTALLATION**

For leaves up to 3 m irreversible.

**M-FAB HS**  
pages 30/31



**M-FAB**  
pages 78/79

24 Vdc version with magnetic encoder.  
Compatible with control units with BlueBUS technology, Solemyo and Opera

Hi-Speed

230 Vac, grease lubrication

increased speed

cruising speed

**MFAB3024**

**MFAB3024HS**

**MFAB3000**

**MFAB3000L**



For leaves up to 4 m irreversible.

**L-FAB**  
pages 80/81

24 Vdc version with magnetic encoder.  
Compatible with control units with BlueBUS technology, Solemyo and Opera

230 Vac

**LFAB4024**

**LFAB4000**



For leaves up to 5 m, irreversible,  
24 Vdc version with magnetic encoder.

Compatible with control units with BlueBUS technology, Solemyo and Opera

**BIG-FAB**  
pages 82/83

**BFAB5024**



FOR SWING GATES

FOR SLIDING GATES

BARRIER GATE OPERATOR SYSTEMS

FOR GARAGE AND INDUSTRIAL DOORS

CONTROL SYSTEMS AND ACCESSORIES

COMPATIBILITY TABLE AND ALPHABETICAL INDEX

# TOONA 4

SOLEMYO OPERA BLUEBUS 24V 230V

## For swing gates with leaves up to 3 m.

Electromechanical gear motor, surface mounted.

Also available in 24 Vdc version, with magnetic encoder.

Ideal for residential use.

**Reliable:** durability thanks to the housing, made up of two tough aluminium shells with polyester paint finish; more resistant to atmospheric agents.

Internal moving parts completely in steel, light alloys and technopolymers.

**Silent:** patented layout of internal parts and lead nut in bronze.

## Generously sized and practical connection compartment:

rapid and easy access from above to internal parts located in the upper section of the motor.

## Simple installation and maintenance;

with built-in capacitor.

## Recommended control units:

Mindy A6F, A60, A700F; for T04024 Moonclever MC824H.

**24 Vdc version** with magnetic encoder.

**Perfect for intensive use**, compatible with the control unit

Moonclever MC824H:

- simple programming, by means of a single key;
- self-learning of opening and closing limit positions;
- automatic fault diagnostics;
- programming of pause time;
- pedestrian pass door;
- deceleration on opening and closing;
- obstacle detection with dual technology;
- operation in event of power failure by means of optional rechargeable batteries (PS324);
- provision for connection of latest generation resistive sensitive edges.

CODE	DESCRIPTION	PACK/PALLET
<b>T04024</b>	IRREVERSIBLE, 24 Vdc, WITH MAGNETIC ENCODER, MECHANICAL STOP ON OPENING	20
<b>T04005</b>	IRREVERSIBLE, 230 Vac, INCREASED SPEED, WITH LIMIT SWITCH ON OPENING	20
<b>T04006</b>	IRREVERSIBLE, 230 Vac, INCREASED SPEED, WITH LIMIT SWITCH ON OPENING AND CLOSING	20
<b>T04015</b>	IRREVERSIBLE, 230 Vac, CRUISING SPEED, WITH LIMIT SWITCH ON OPENING	20
<b>T04605</b>	REVERSIBLE, 230 Vac, INCREASED SPEED, WITH LIMIT SWITCH ON OPENING	20

## TECHNICAL SPECIFICATIONS

CODE	T04024	T04005	T04006	T04015	T04605
<b>ELECTRICAL DATA</b>					
POWER SUPPLY (Vac 50 Hz)*	-	230			
POWER SUPPLY (Vdc)	24	-			
ABSORPTION (A)	5	1.5		1.3	
POWER (W)	120	340		300	
<b>PERFORMANCE DATA</b>					
SPEED (m/s)	0.016		0.013		0.016
FORCE (N)	1800				
WORK CYCLE (CYCLES/HOUR)	95**	58		54	50
<b>DIMENSIONAL AND GENERAL DATA</b>					
PROTECTION LEVEL (IP)	44				
WORKING TEMP. (°C MIN/MAX)	-20 ÷ +50				
DIMENSIONS (mm)	820x115x105 h				
WEIGHT (kg)	6				

\*60 Hz version available on request.

\*\* With optimal installation.

EASY ACCESS TO INTERNAL PARTS IN UPPER SECTION OF MOTOR

RELEASE HANDLE IN DIE-CAST ALUMINIUM, PRACTICAL AND RESISTANT

EXCLUSIVE PATENTED LAYOUT OF INTERNAL PARTS



## UTILISATION LIMITS

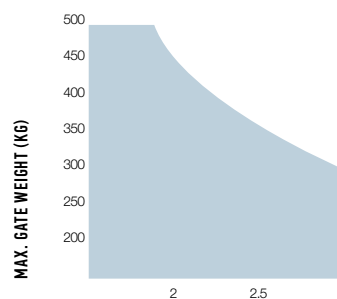

The shape, the height of the gate and the weather conditions can considerably reduce the values shown in the graph to the side. Use in windy areas 230 Vac models.

## DIMENSIONS

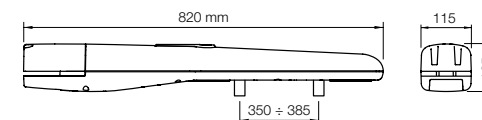

Nice recommends customers order products in pallets in order to facilitate storage and delivery, and ensure packs are uniform. The number of packs per single pallet has been specified for this reason. Approximate draft.

## INSTALLATION DIAGRAM

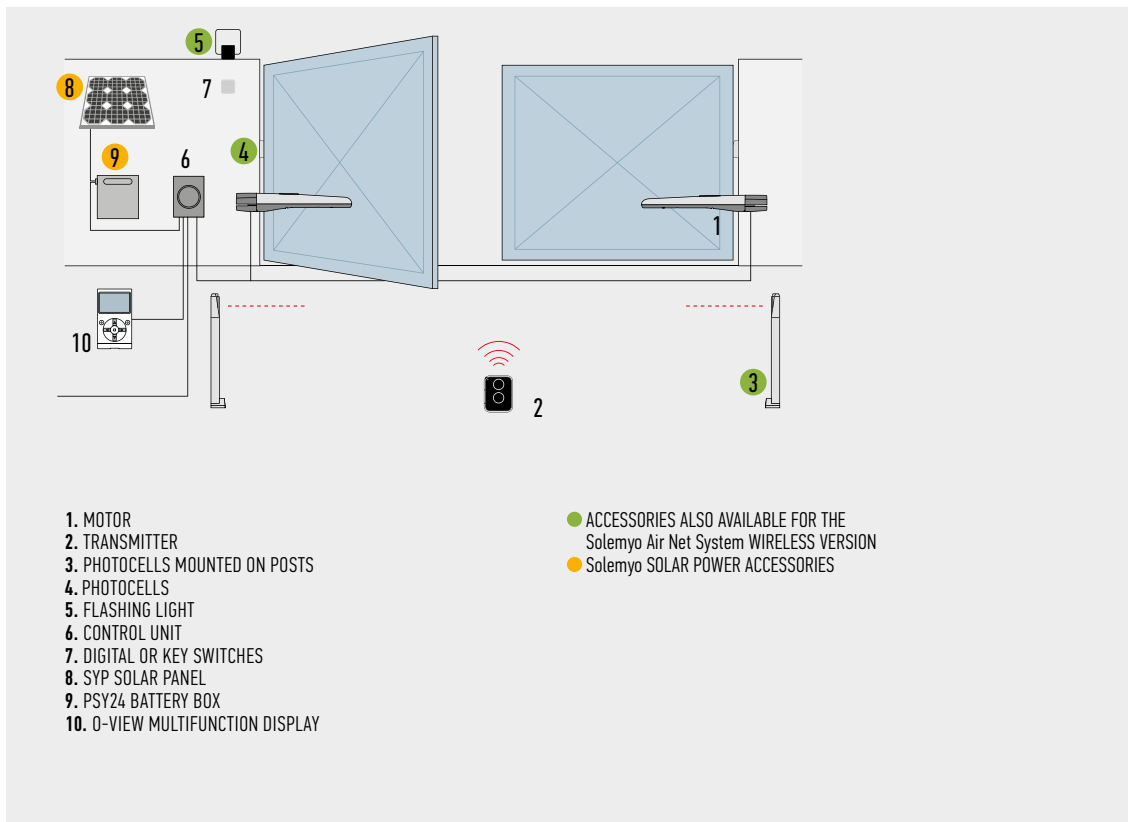

## COMPATIBILITY TABLE WITH CONTROL SYSTEMS AND ACCESSORIES

CODE	CONTROL UNIT / RECEIVER										TRANSMITTER				PHOTOCELLS							FLASHING LIGHT							
	A01 / Built-in*	A02 / Built-in*	A6F / FLOX12R*	A700F / FLOX12R*	A60 / OX1-SMX1*	A500 / FLOX12R*	A924 / FLOX12R*	MC424L / OXI	MC824H / OXI	MC824HR / OXI	ERA INTI	ERA ONE	ERA FLOR	NICEWAY	EPS	EPM	EPL	EPSB	EPMB	EPLB	F210	FT210	F210B	FT210B	EL	EL24	ELB	WLT	
<b>T04024</b>										●	●	●	●	●	●	●	●	●	●										
<b>T04005</b>			●	●	●					●	●	●	●	●	●	●	●	●	●		●	●			●				
<b>T04006</b>			●	●	●					●	●	●	●	●	●	●	●	●	●		●	●			●				
<b>T04015</b>			●	●	●					●	●	●	●	●	●	●	●	●	●		●	●			●				
<b>T04605</b>			●	●	●					●	●	●	●	●	●	●	●	●	●		●	●			●				

\*Radio receiver incompatible with Opera system

## ACCESSORIES

Total interchangeability with the series Moby: identical positions and fixing brackets

**PLA6**  
REAR BRACKET  
250 mm LONG.  
PC/PACK 1

**PLA14**  
SCREW-ADJUSTABLE  
REAR BRACKET.  
PC/PACK 2

**PLA15**  
SCREW-ADJUSTABLE  
FRONT BRACKET.  
PC/PACK 2

**PLA10**  
VERTICAL 12 V ELECTRIC  
LOCK (REQUIRED FOR GATES  
LONGER THAN 3 m).  
PC/PACK 1

**ACCESSORY**  
For 24 Vdc version

**PLA11**  
HORIZONTAL 12 V ELECTRIC  
LOCK (REQUIRED FOR GATES  
LONGER THAN 3 m).  
PC/PACK 1

**PLA13**  
MECHANICAL TRAVEL STOPS  
FOR CLOSING OR OPENING  
MANOEUVRES.  
PC/PACK 4

**TS**  
SIGNBOARD.  
PC/PACK 1

**PS324**  
24 V BATTERY  
WITH INTEGRATED  
BATTERY CHARGER.  
PC/PACK 1



**KIT SOLEMYO**  
THE SOLAR POWER TO  
AUTOMATE GATES, GARAGE  
DOORS OR BARRIER GATES.  
SEE PAGE 200

FOR SWING GATES

FOR SLIDING GATES

BARRIER GATE  
OPERATOR SYSTEMS

FOR GARAGE  
AND INDUSTRIAL DOORS

CONTROL SYSTEMS  
AND ACCESSORIES

COMPATIBILITY TABLE  
AND ALPHABETICAL INDEX

# TOONA 5

SOLEMYO OPERA BLUEBUS 24V 230V

## For swing gates with leaves up to 5 m.

Electromechanical gear motor, surface mounted.  
Also available in 24 Vdc version, with magnetic encoder.  
Ideal for residential and industrial use.

**Reliable:** durability thanks to the housing, made up of two tough aluminium shells with polyester paint finish; more resistant to atmospheric agents.

Internal moving parts completely in steel, light alloys and technopolymers.

**T05024I** ideal for intensive work load, thanks to the torque of 2200 Nm, can work on continuous duty on large sized gates.

**Silent:** patented layout of internal parts and lead nut in bronze.

**Generously sized and practical connection compartment:** rapid and easy access from above to internal parts located in the upper section of the motor.

**Simple installation and maintenance,** with built-in capacitor.

### Recommended control units:

Mindy A6F, A60, A700F;  
for T05024 and T05024I Moonclever MC824H.

**24 Vdc version** with magnetic encoder.

**Perfect for intensive use,** compatible with the control unit Moonclever MC824H:

- simple programming, by means of a single key;
- self-learning of opening and closing limit positions;
- automatic fault diagnostics;
- programming of pause time;
- pedestrian pass door;
- deceleration on opening and closing;
- obstacle detection with dual technology;
- operation in event of power failure by means of optional rechargeable batteries (PS324);
- provision for connection of latest generation resistive sensitive edges.

CODE	DESCRIPTION	PACK/PALLET
<b>T05024</b>	IRREVERSIBLE, 24 Vdc, WITH MAGNETIC ENCODER, MECHANICAL STOP ON OPENING	20
<b>T05024I</b>	IRREVERSIBLE, 24 Vdc, WITH MAGNETIC ENCODER, MECHANICAL STOP ON OPENING; FOR INTENSIVE USE	20
<b>T05015</b>	IRREVERSIBLE, 230 Vac, CRUISING SPEED, WITH LIMIT SWITCH ON OPENING	20
<b>T05016</b>	IRREVERSIBLE, 230 Vac, CRUISING SPEED, WITH LIMIT SWITCH ON OPENING AND CLOSING	20
<b>T05605</b>	REVERSIBLE, 230 Vac, INCREASED SPEED, WITH LIMIT SWITCH ON OPENING	20

## TECHNICAL SPECIFICATIONS

CODE	T05024	T05024I	T05015	T05016	T05605
<b>ELECTRICAL DATA</b>					
POWER SUPPLY (Vac 50 Hz)*	-		230		
POWER SUPPLY (Vdc)	24		-		
ABSORPTION (A)	5		1.5		1.3
POWER (W)	120		340		300
<b>PERFORMANCE DATA</b>					
SPEED (m/s)	0.016		0.013		0.016
FORCE (N)	1800		2200		1800
WORK CYCLE (CYCLES/HOUR)	95**		75***		54
<b>DIMENSIONAL AND GENERAL DATA</b>					
PROTECTION LEVEL (IP)	44				
WORKING TEMP. (°C MIN/MAX)	-20 ÷ +50				
DIMENSIONS (mm)	965x115x105 h				
WEIGHT (kg)	7				

\*60 Hz version available on request.

\*\* With optimal installation.

\*\*\* The reduction in number of manoeuvres with respect to the version T05024 depends solely on the lower manoeuvre speed.

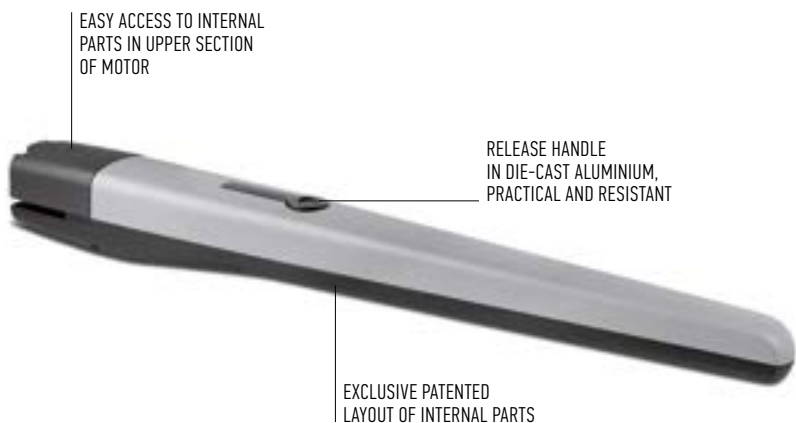

## UTILISATION LIMITS

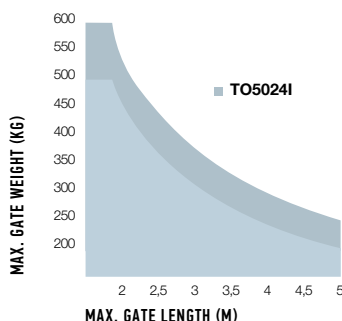

## DIMENSIONS

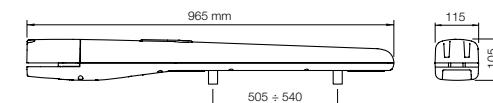

The shape, the height of the gate and the weather conditions can considerably reduce the values shown in the graph to the side. Use in windy areas 230 Vac models.

## INSTALLATION DIAGRAM

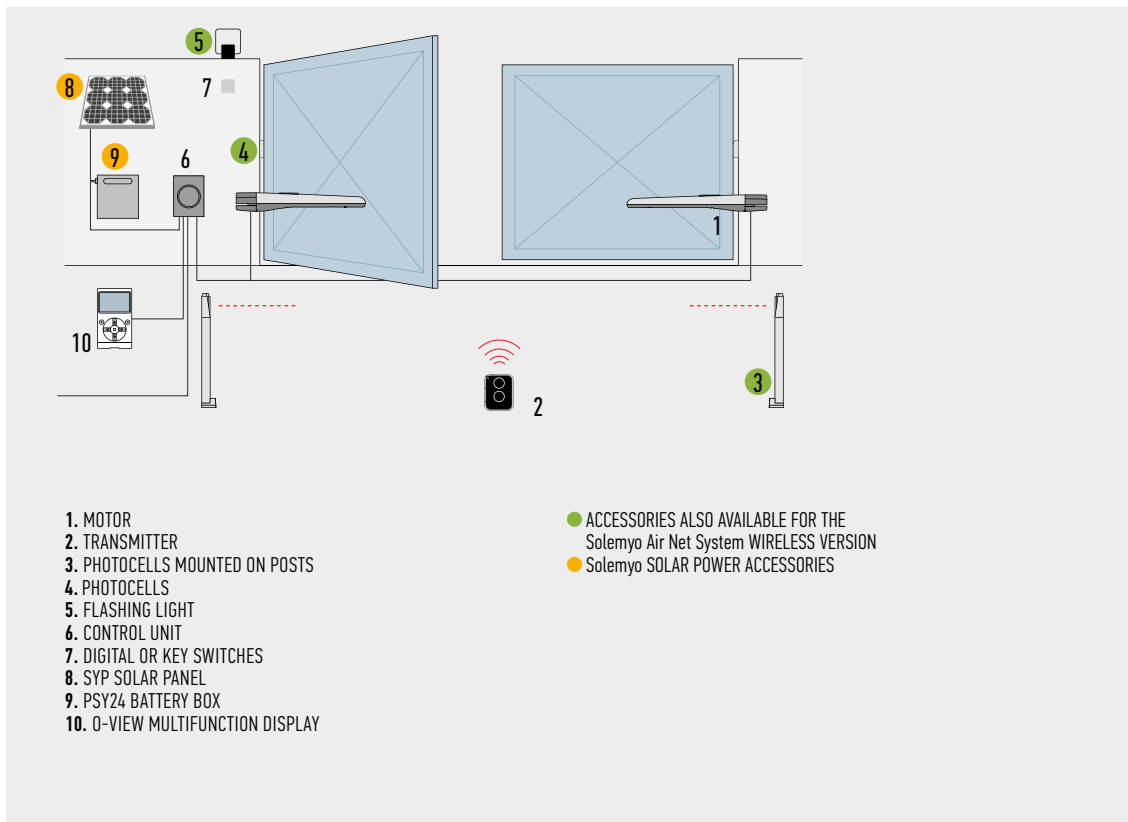

## COMPATIBILITY TABLE WITH CONTROL SYSTEMS AND ACCESSORIES

CODE	CONTROL UNIT / RECEIVER								TRANSMITTER				PHOTOCELLS							FLASHING LIGHT								
	A01 / Built-in*	A02 / Built-in*	A6F / FLOX12R*	A700F / FLOX12R*	A60 / OXI-SMX1*	A500 / FLOX12R*	A924 / FLOX12R*	MC424L / OXI	MC824H / OXI	MC824HR / OXI	ERA INTI	ERA ONE	ERA FLOR	NICEWAY	EPS	EPM	EPL	EPSB	EPMB	EPLB	F210	FT210	F210B	FT210B	EL	EL24	ELB	WLT
T05024								●		●	●	●	●				●	●	●								●	●
T05024I								●		●	●	●	●				●	●	●				●				●	●
T05015			●	●	●					●	●	●	●								●	●			●			
T05016			●	●	●					●	●	●	●								●	●			●			
T05605			●	●	●					●	●	●	●								●	●			●			

\*Radio receiver incompatible with Opera system

## ACCESSORIES

Total interchangeability with the series Moby: identical positions and fixing brackets

**PLA6**  
REAR BRACKET  
250 mm LONG.  
PC/PACK 1

**PLA8**  
SCREW-ADJUSTABLE  
FRONT BRACKET.  
PC/PACK 1

**PLA10**  
VERTICAL 12 V ELECTRIC  
LOCK (REQUIRED FOR GATES  
LONGER THAN 3 m).  
PC/PACK 1

**PLA11**  
HORIZONTAL 12 V ELECTRIC  
LOCK (REQUIRED FOR GATES  
LONGER THAN 3 m).  
PC/PACK 1

**ACCESSORY**  
For 24 Vdc version

**PLA13**  
MECHANICAL TRAVEL STOPS  
FOR CLOSING AND OPENING  
MANOEUVRES.  
PC/PACK 4

**TS**  
SIGNBOARD.  
PC/PACK 1

**PS324**  
24 V BATTERY  
WITH INTEGRATED  
BATTERY CHARGER.  
PC/PACK 1



**KIT SOLEMYO**  
THE SOLAR POWER TO  
AUTOMATE GATES, GARAGE  
DOORS OR BARRIER GATES.  
SEE PAGE 200

# TOONA 7

SOLEMYO OPERA BLUEBUS 24V

## For swing gates with leaves up to 7 m.

Electromechanical gear motor, surface mounted, powered at 24 Vdc, with magnetic encoder. Ideal for industrial installations, designed for intensive use.

**Reliable:** durability thanks to the housing, made up of two tough aluminium shells with polyester paint finish; more resistant to atmospheric agents.

Internal moving parts completely in steel, light alloys and technopolymers.

**Silent:** patented layout of internal parts and lead nut in bronze.

**Generously sized and practical connection compartment:** rapid and easy access from above to internal parts located in the upper section of the motor.

### Moonclever MC824H control unit:

- simple programming, by means of a single key;
- self-learning of opening and closing limit positions;
- automatic fault diagnostics;
- programming of pause time;
- pedestrian pass door;
- deceleration on opening and closing;
- obstacle detection with dual technology;
- operation in event of power failure by means of optional rechargeable batteries (PS324);
- provision for connection of latest generation resistive sensitive edges.



CODE	DESCRIPTION	PACK/PALLET
T07024	IRREVERSIBLE, 24 Vdc, WITH MAGNETIC ENCODER, MECHANICAL STOP ON OPENING AND CLOSING	20

### TECHNICAL SPECIFICATIONS

CODE	T07024
<b>ELECTRICAL DATA</b>	
POWER SUPPLY (Vac 50 Hz)	-
POWER SUPPLY (Vdc)	24
ABSORPTION (A)	5
POWER (W)	120
<b>PERFORMANCE DATA</b>	
SPEED (m/s)	0.013
FORCE (N)	2700
WORK CYCLE (CYCLES/HOUR)	41
<b>DIMENSIONAL AND GENERAL DATA</b>	
PROTECTION LEVEL (IP)	44
WORKING TEMP. (°C MIN/MAX)	-20 ÷ +50
DIMENSIONS (mm)	1200x128x150 h
WEIGHT (kg)	15

### UTILISATION LIMITS

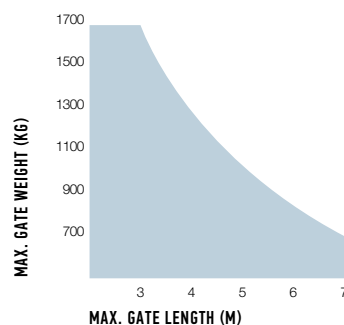

### DIMENSIONS

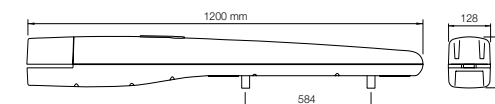

The shape, the height of the gate and the weather conditions can considerably reduce the values shown in the graph to the side.

## INSTALLATION DIAGRAM

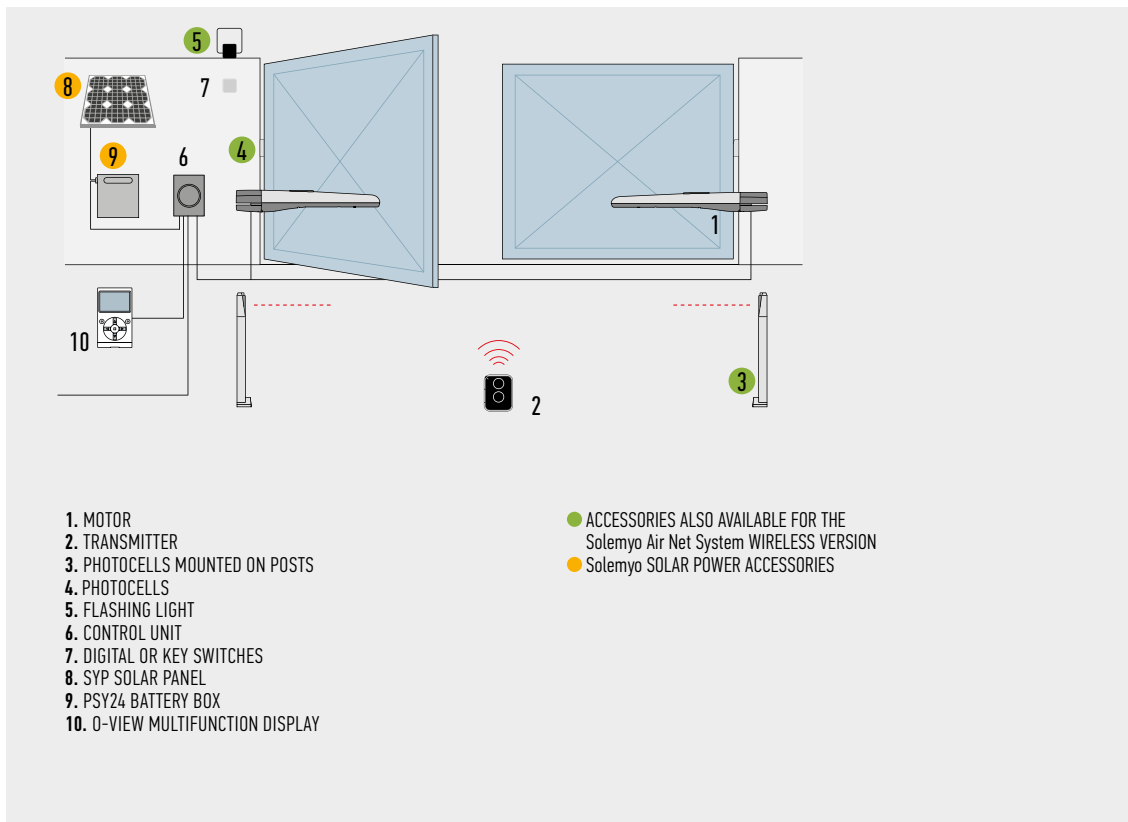

## COMPATIBILITY TABLE WITH CONTROL SYSTEMS AND ACCESSORIES

CODE	CONTROL UNIT / RECEIVER							TRANSMITTER				PHOTOCELLS							FLASHING LIGHT							
	A01 / Built-in*	A02 / Built-in*	A6F / FLOX12R*	A700F / FLOX12R*	A60 / OX1-SMX1*	A500 / FLOX12R*	A924 / FLOX12R*	MC424L / OXI	MC824H / OXI	ERA INTI	ERA ONE	ERA FLOR	NICEWAY	EPS	EPM	EPL	EPSB	EPMB	EPLB	F210	FT210	F210B	FT210B	EL	EL24	ELB
<b>T07024</b>								●	●	●	●	●				●	●	●			●				●	●

\*Radio receiver incompatible with Opera system

## ACCESSORIES



**PLA10**  
VERTICAL 12 V ELECTRIC LOCK (REQUIRED FOR GATES LONGER THAN 3 m).  
PC/PACK 1



**PLA11**  
HORIZONTAL 12 V ELECTRIC LOCK (REQUIRED FOR GATES LONGER THAN 3 m).  
PC/PACK 1



**TS**  
SIGNBOARD.  
PC/PACK 1



**PS324**  
24 V BATTERY WITH INTEGRATED BATTERY CHARGER.  
PC/PACK 1



**KIT SOLEMYO**  
THE SOLAR POWER TO AUTOMATE GATES, GARAGE DOORS OR BARRIER GATES. SEE PAGE 200

Nice recommends customers order products in pallets in order to facilitate storage and delivery, and ensure packs are uniform. The number of packs per single pallet has been specified for this reason. Approximate draft.

FOR SWING GATES

FOR SLIDING GATES

BARRIER GATE OPERATOR SYSTEMS

FOR GARAGE AND INDUSTRIAL DOORS

CONTROL SYSTEMS AND ACCESSORIES

COMPATIBILITY TABLE AND ALPHABETICAL INDEX

# TOONAKIT

SOLEMYO OPERA BLUEBUS 24V

**For swing gates with leaves up to 3 m,**  
ideal for residential use.

Electromechanical gear motor, surface mounted,  
powered at 24 Vdc, with magnetic encoder.

**Reliable:** durability thanks to the housing, made up of two tough aluminium shells with polyester paint finish;  
more resistant to atmospheric agents.

Internal moving parts completely in steel, light alloys  
and technopolymers.

**Silent:** patented layout of internal parts and lead nut  
in bronze.

**Generously sized and practical connection compartment:**  
rapid and easy access from above to internal parts located  
in the upper section of the motor.

**Ease of installation and maintenance.**

**Moonclever MC824H control unit:**

- simple programming, by means of a single key;
- self-learning of opening and closing limit positions;
- automatic fault diagnostics;
- programming of pause time;
- pedestrian pass door;
- deceleration on opening and closing;
- obstacle detection with dual technology;
- operation in event of power failure by means of optional rechargeable batteries (PS324);
- provision for connection of latest generation resistive sensitive edges.

**NEW** The new Era Gate accessories,  
with a minimal, modern and discreet design,  
renovate Nice kits' style and performance.

Discover the complete range at page 184

CODE	DESCRIPTION	PACK/PALLET
TOONA4024KCE	KIT FOR SWING GATES WITH LEAVES UP TO 3 m, 24 Vdc, SURFACE MOUNTED	12

**N.B.** The content of the package may vary; consult the retailer.

## TECHNICAL SPECIFICATIONS

CODE	T04024
<b>ELECTRICAL DATA</b>	
POWER SUPPLY (Vdc)	24
ABSORPTION (A)	5
POWER (W)	120
<b>PERFORMANCE DATA</b>	
SPEED (m/s)	0.016
FORCE (N)	1800
WORK CYCLE (CYCLES/HOUR)	95*
<b>DIMENSIONAL AND GENERAL DATA</b>	
PROTECTION LEVEL (IP)	44
WORKING TEMP. (°C MIN/MAX)	-20 ÷ +50
DIMENSIONS (mm)	820x115x105 h
WEIGHT (kg)	6

\* With optimal installation.

## UTILISATION LIMITS

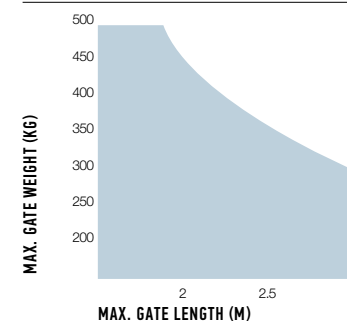

The shape, the height of the gate and the weather conditions can considerably reduce the values shown in the graph to the side.

## DIMENSIONS

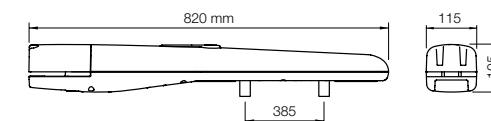

## THE KIT CONTAINS:

**T04024**  
2 ELECTROMECHANICAL IRREVERSIBLE GEAR  
MOTORS, SURFACE MOUNTED.  
WITH MECHANICAL STOP ON OPENING.



**0N2E**  
1 TRANSMITTER  
433.92 MHz, 2 CHANNELS.



**MC824H**  
1 CONTROL UNIT  
WITH OXI PLUG-IN RECEIVER.



**NEW**  
**EPMB**  
1 COUPLE OF EXTERNAL  
PHOTOCELLS DESIGNED FOR  
CONNECTION BY NICE BLUEBUS.



**NEW**  
**EKS**  
1 KEY SELECTOR SWITCH FOR  
OUTDOOR INSTALLATION.



**NEW**  
**ELB**  
1 FLASHING LIGHT  
WITH INTEGRATED AERIAL.



**TS**  
1 SIGNBOARD.





## INSTALLATION DIAGRAM

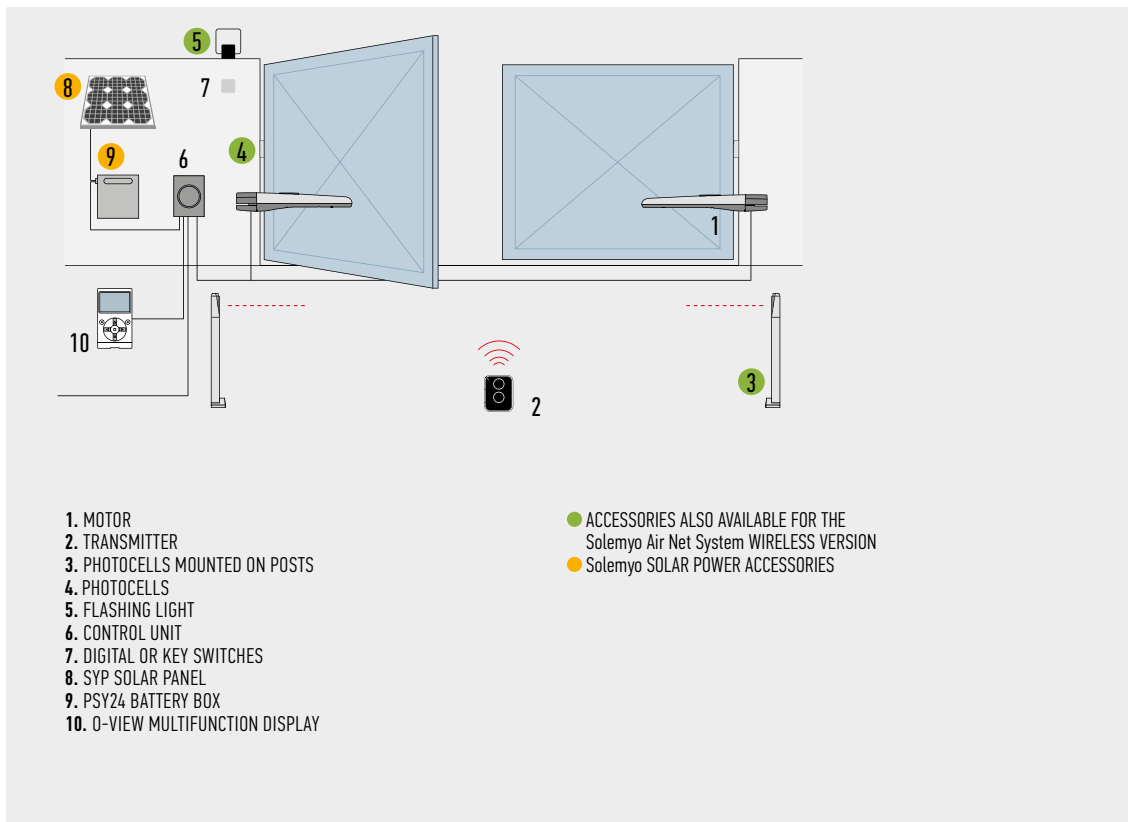

## ACCESSORIES

Total interchangeability with the series Moby: identical positions and fixing brackets



**PLA6**  
 REAR BRACKET  
 250 mm LONG.  
 PC/PACK 1



**PLA14**  
 SCREW-ADJUSTABLE  
 REAR BRACKET.  
 PC/PACK 2



**PLA15**  
 SCREW-ADJUSTABLE  
 FRONT BRACKET.  
 PC/PACK 2



**PLA10**  
 VERTICAL 12 V ELECTRIC  
 LOCK (REQUIRED FOR GATES  
 LONGER THAN 3 m).  
 PC/PACK 1



**PLA11**  
 HORIZONTAL 12 V ELECTRIC LOCK  
 (REQUIRED FOR GATES  
 LONGER THAN 3 m).  
 PC/PACK 1



**PLA13**  
 MECHANICAL TRAVEL STOPS  
 FOR CLOSING AND OPENING  
 MANOEUVRES.  
 PC/PACK 4



**PS324**  
 24 V BATTERY  
 WITH INTEGRATED  
 BATTERY CHARGER.  
 PC/PACK 1



**KIT SOLEMYO**  
 THE SOLAR POWER TO  
 AUTOMATE GATES, GARAGE  
 DOORS OR BARRIER GATES.  
 SEE PAGE 200

FOR SWING GATES

FOR SLIDING GATES

BARRIER GATE  
 OPERATOR SYSTEMS

FOR GARAGE  
 AND INDUSTRIAL DOORS

CONTROL SYSTEMS  
 AND ACCESSORIES

COMPATIBILITY TABLE  
 AND ALPHABETICAL INDEX

# WINGOKIT

230V

**For swing gates with leaves up to 2 m, surface mounted.**

**Reliable and silent:** patented layout of internal parts, fewer moving parts.

**Easy to install:** after the gear motor has been assembled, all electrical connections are made from above.

**Built-in capacitor.**

**User-friendly release** with personalised Nice key and standard lock included.

**Pre-assembled,** travel stops on opening.

**A60 control unit** for two 230 Vac motors with electronic clutch and slowdown, IP55 casing.

NEW

**The new Era Gate accessories,** with a minimal, modern and discreet design, renovate Nice kits' style and performance.

Discover the complete range at page 184

CODE	DESCRIPTION	PACK/PALLET
WINGOKCE/A60	KIT FOR SWING GATES WITH LEAVES UP TO 2 m, SURFACE MOUNTED	12

**N.B.** The content of the package may vary: consult the retailer.

## TECHNICAL SPECIFICATIONS

CODE	WG4000
<b>ELECTRICAL DATA</b>	
POWER SUPPLY (Vac 50 Hz)*	230
ABSORPTION (A)	1.5
POWER (W)	200
<b>PERFORMANCE DATA</b>	
SPEED (m/s)	0.016
FORCE (N)	1500
WORK CYCLE (CYCLES/HOUR)	30
<b>DIMENSIONAL AND GENERAL DATA</b>	
PROTECTION LEVEL (IP)	44
WORKING TEMP. (°C MIN/MAX)	-20 ÷ +50
DIMENSIONS (mm)	770x98x95 h
WEIGHT (kg)	6

\*60 Hz version available on request.

## UTILISATION LIMITS

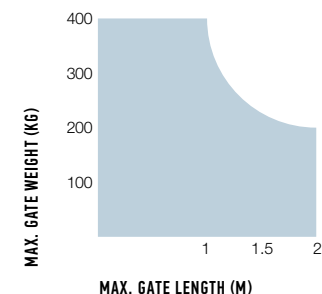

## DIMENSIONS

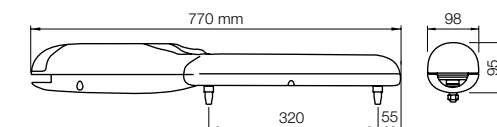

## THE KIT CONTAINS:

**WG4000**  
2 SURFACE-MOUNTED ELECTROMECHANICAL GEAR MOTORS, WITH NICE KEY RELEASE AND MECHANICAL STOP ON OPENING.

**FLO2RE**  
1 TRANSMITTER  
433.92 MHz, 2 CHANNELS.

**A60**  
1 CONTROL UNIT A60  
WITH SMXI PLUG-IN RECEIVER.

NEW

**EPM**  
1 PAIR OF PHOTOCELLS  
FOR OUTDOOR INSTALLATION.

NEW

**EKS**  
1 KEY SELECTOR SWITCH  
FOR OUTDOOR INSTALLATION.

NEW

**EL**  
1 FLASHING LIGHT WITH  
INTEGRATED AERIAL.

**TS**  
1 SIGNBOARD.



## INSTALLATION DIAGRAM

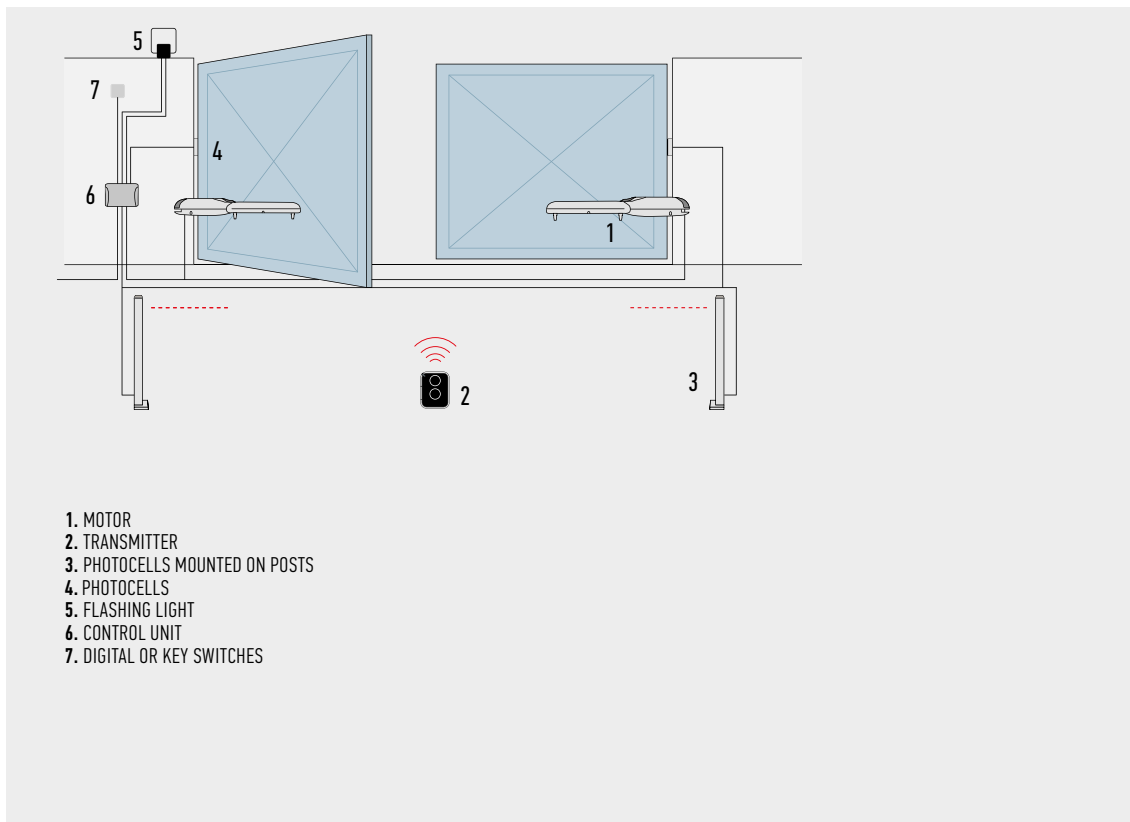

## ACCESSORIES



**PLA14**  
 SCREW-ADJUSTABLE  
 REAR BRACKET.

PC/PACK 2



**PLA15**  
 SCREW-ADJUSTABLE  
 FRONT BRACKET.

PC/PACK 2

Nice recommends customers order products in order to facilitate storage and delivery, and ensure packs are uniform. The number of packs per single pallet has been specified for this reason. Approximate draft.

FOR SWING GATES

FOR SLIDING GATES

BARRIER GATE  
 OPERATOR SYSTEMS

FOR GARAGE  
 AND INDUSTRIAL DOORS

CONTROL SYSTEMS  
 AND ACCESSORIES

COMPATIBILITY TABLE  
 AND ALPHABETICAL INDEX

# WINGOKIT 4024

SOLEMYO 24V

**For swing gates with leaves up to 2 m, surface mounted.**

24 Vdc electromechanical gear motor.

**Reliable and silent:**

patented layout of internal parts, fewer moving parts.

**Easy to install:** after the gear motor has been assembled, all electrical connections are made from above.

**User-friendly release** with personalised Nice key and standard lock included.

**Pre-assembled,** travel stops on opening.

**Moonclever control unit MC424L:**

- simple programming, by means of a single key;
- clutch with anti-crush safety feature;
- automatic memorization of limit switches on opening and closing with self-learning function;
- programming of pause time;
- pedestrian pass door;
- deceleration on opening and closing;
- obstacle detection system;
- can be linked to the 8.2 KOhm resistive sensitive edge;
- continues to work even during power failures using optional (PS124) batteries that fit inside the control unit.



**The new Era Gate accessories,** with a minimal, modern and discreet design, renovate Nice kits' style and performance.

Discover the complete range at page 184

CODE	DESCRIPTION	PACK/PALLET
WINGO4024KCE	KIT FOR SWING GATES WITH LEAVES UP TO 2 m, 24 Vdc, SURFACE MOUNTED	12

**N.B.** The content of the package may vary: consult the retailer.

**TECHNICAL SPECIFICATIONS**

CODE	WG4024
<b>ELECTRICAL DATA</b>	
POWER SUPPLY (Vdc)	24
ABSORPTION (A)	3.5
POWER (W)	85
<b>PERFORMANCE DATA</b>	
SPEED (m/s)	0.018
FORCE (N)	1500
WORK CYCLE (CYCLES/HOUR)	30
<b>DIMENSIONAL AND GENERAL DATA</b>	
PROTECTION LEVEL (IP)	44
WORKING TEMP. (°C MIN/MAX)	-20 ÷ +50
DIMENSIONS (mm)	770x98x95 h
WEIGHT (kg)	6

**UTILISATION LIMITS**

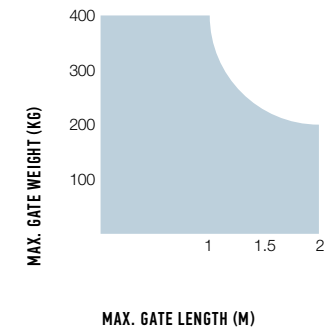

**DIMENSIONS**

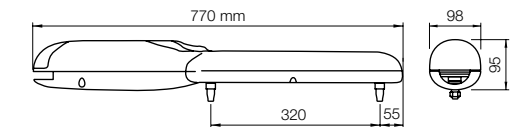

**THE KIT CONTAINS:**

**WG4024**  
2 SURFACE-MOUNTED ELECTROMECHANICAL GEAR MOTORS, WITH NICE KEY RELEASE AND MECHANICAL STOP ON OPENING.

**FL02RE**  
1 TRANSMITTER 433.92 MHz, 2 CHANNELS.

**MC424L**  
1 CONTROL UNIT WITH SMXI PLUG-IN RECEIVER.



**EPM**  
1 PAIR OF PHOTOCELLS FOR OUTDOOR INSTALLATION.



**EKS**  
1 KEY SELECTOR SWITCH FOR OUTDOOR INSTALLATION.



**EL24**  
1 FLASHING LIGHT WITH INTEGRATED AERIAL.

**TS**  
1 SIGNBOARD.



## INSTALLATION DIAGRAM

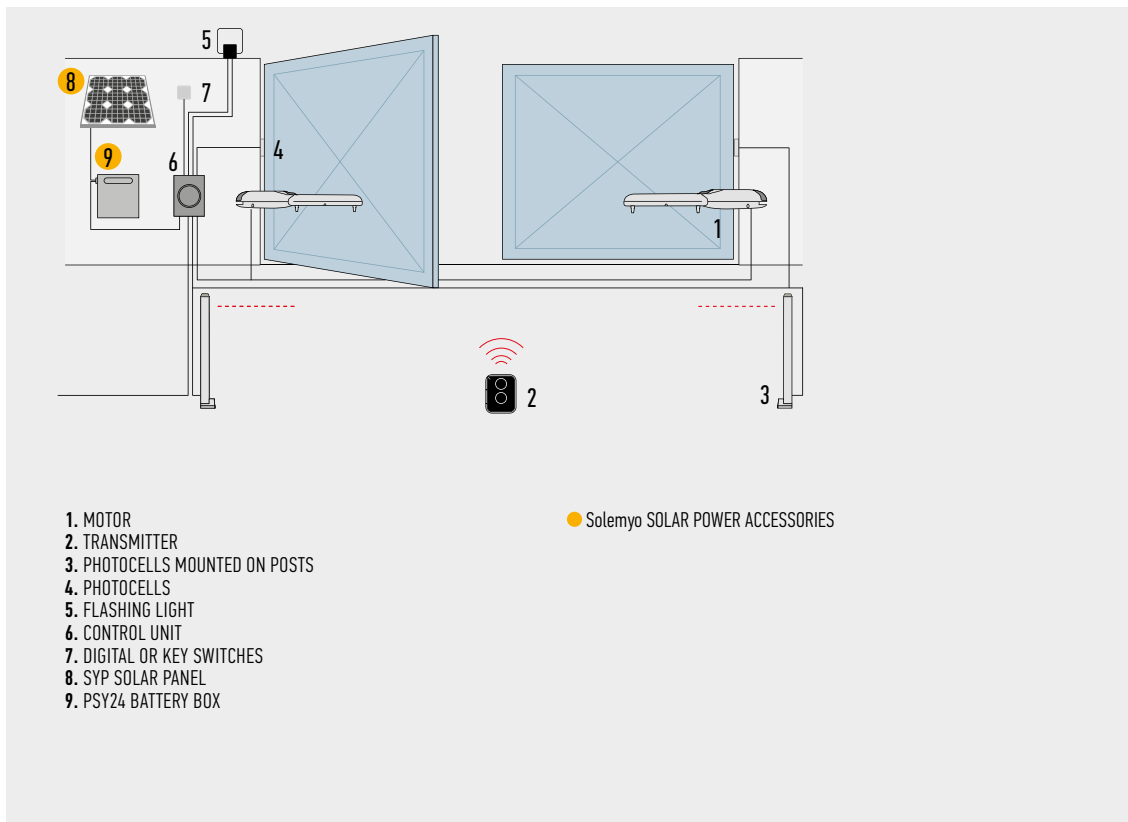

Nice recommends customers order products in pallets in order to facilitate storage and delivery, and ensure packs are uniform. The number of packs per single pallet has been specified for this reason. Approximate draft.

## ACCESSORIES



**PS124**  
 24 V BATTERY  
 WITH INTEGRATED  
 BATTERY CHARGER.  
 PC/PACK 1



**PLA14**  
 SCREW-ADJUSTABLE  
 REAR BRACKET.  
 PC/PACK 2



**PLA15**  
 SCREW-ADJUSTABLE  
 FRONT BRACKET.  
 PC/PACK 2



**PLA10**  
 VERTICAL 12 V ELECTRIC  
 LOCK.  
 PC/PACK 1



**PLA11**  
 HORIZONTAL 12 V ELECTRIC  
 LOCK.  
 PC/PACK 1



 **KIT SOLEMYO**  
 THE SOLAR POWER TO  
 AUTOMATE GATES, GARAGE  
 DOORS OR BARRIER GATES.  
 SEE PAGE 200

FOR SWING GATES

FOR SLIDING GATES

BARRIER GATE  
 OPERATOR SYSTEMS

FOR GARAGE  
 AND INDUSTRIAL DOORS

CONTROL SYSTEMS  
 AND ACCESSORIES

COMPATIBILITY TABLE  
 AND ALPHABETICAL INDEX

# WINGO5KIT

230V

**For swing gates with leaves up to 3.5 m, surface mounted.**

**Reliable and silent:** patented layout of internal parts, fewer moving parts.

**Easy to install:** after the gear motor has been assembled, all electrical connections are made from above.

**Built-in capacitor.**

**User-friendly release** with personalised Nice key or standard lock (optional).

**Pre-assembled,** travel stops on opening.

**A60 control unit** for two 230 Vac motors with electronic clutch and slowdown, IP55 casing.

NEW

**The new Era Gate accessories,** with a minimal, modern and discreet design, renovate Nice kits' style and performance.

Discover the complete range at page 184

## THE KIT CONTAINS:

**WG5000**  
2 SURFACE-MOUNTED ELECTROMECHANICAL GEAR MOTORS, WITH NICE KEY RELEASE AND MECHANICAL STOP ON OPENING.

**FL02RE**  
1 TRANSMITTER 433.92 MHz, 2 CHANNELS.

**A60**  
1 CONTROL UNIT WITH SMXI PLUG-IN RECEIVER.

NEW

**EPM**  
1 PAIR OF PHOTOCELLS FOR OUTDOOR INSTALLATION.

NEW

**EKS**  
1 KEY SELECTOR SWITCH FOR OUTDOOR INSTALLATION.

NEW

**EL**  
1 FLASHING LIGHT WITH INTEGRATED AERIAL.

**TS**  
1 SIGNBOARD.



CODE	DESCRIPTION	PACK/PALLET
WINGO5KCE	KIT FOR SWING GATES WITH LEAVES UP TO 3.5 m, SURFACE MOUNTED	12

**N.B.** The content of the package may vary; consult the retailer.

## TECHNICAL SPECIFICATIONS

CODE	WG5000
<b>ELECTRICAL DATA</b>	
POWER SUPPLY (Vac 50 Hz)*	230
ABSORPTION (A)	1.5
POWER (W)	200
<b>PERFORMANCE DATA</b>	
SPEED (m/s)	0.013
FORCE (N)	1700
WORK CYCLE (CYCLES/HOUR)	30
<b>DIMENSIONAL AND GENERAL DATA</b>	
PROTECTION LEVEL (IP)	44
WORKING TEMP. (°C MIN/MAX)	-20 ÷ +50
DIMENSIONS (mm)	920x98x95 h
WEIGHT (kg)	6

\*60 Hz version available on request.

## UTILISATION LIMITS

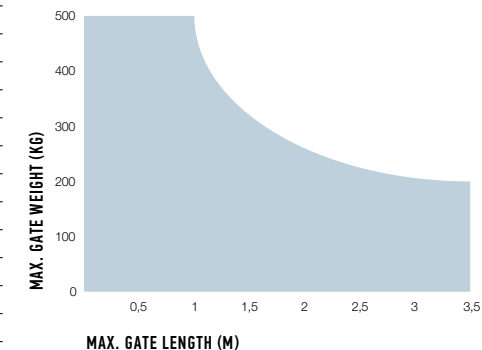

## DIMENSIONS

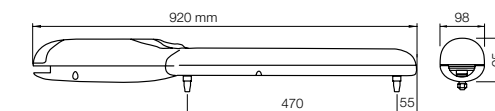

## INSTALLATION DIAGRAM

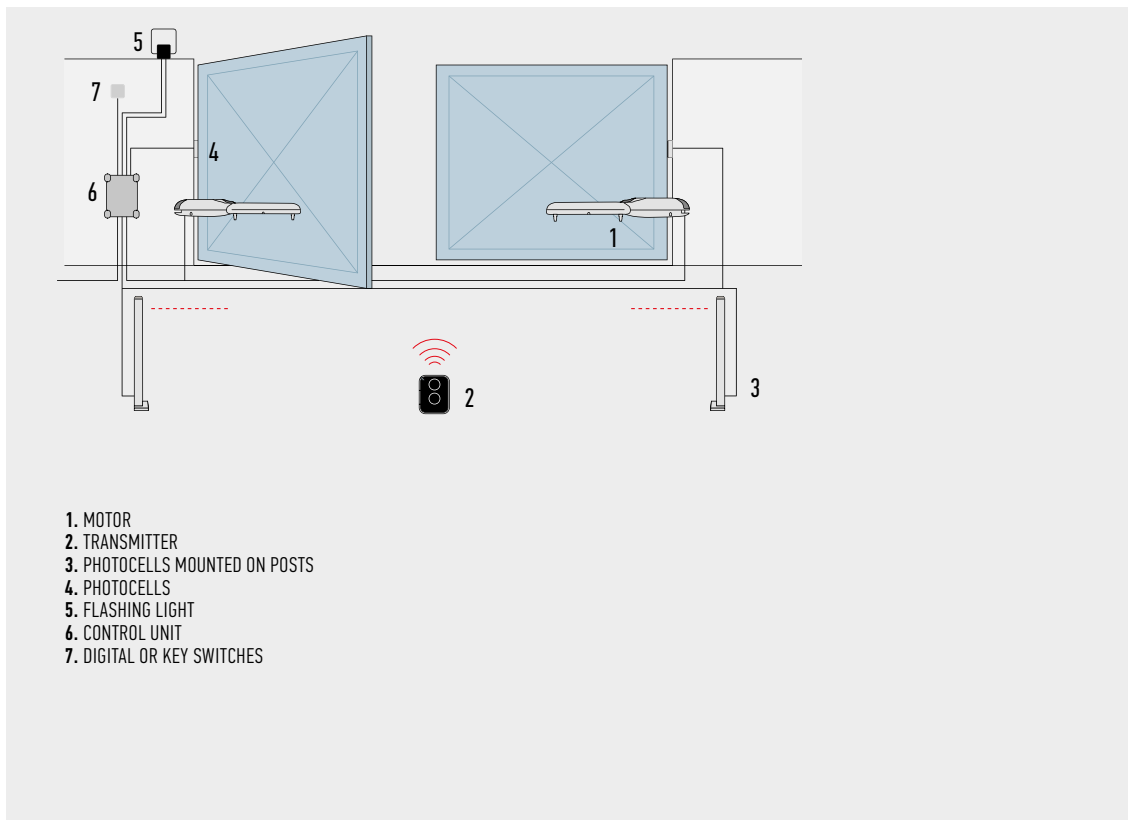

Nice recommends customers order products in pallets in order to facilitate storage and delivery, and ensure packs are uniform. The number of packs per single pallet has been specified for this reason. Approximate draft.

## ACCESSORIES



**PLA6**  
 REAR BRACKET  
 250 mm LONG.  
 PC/PACK 1



**PLA8**  
 SCREW-ADJUSTABLE  
 FRONT BRACKET.  
 PC/PACK 1



**PLA10**  
 VERTICAL 12 V ELECTRIC  
 LOCK (REQUIRED FOR GATES  
 LONGER THAN 3 m).  
 PC/PACK 1



**PLA11**  
 HORIZONTAL 12 V ELECTRIC  
 LOCK (REQUIRED FOR GATES  
 LONGER THAN 3 m).  
 PC/PACK 1

FOR SWING GATES

FOR SLIDING GATES

BARRIER GATE  
 OPERATOR SYSTEMS

FOR GARAGE  
 AND INDUSTRIAL DOORS

CONTROL SYSTEMS  
 AND ACCESSORIES

COMPATIBILITY TABLE  
 AND ALPHABETICAL INDEX

# WINGOKIT 5024

SOLEMYO 24V

**For swing gates with leaves up to 3.5 m, surface mounted.**

24 Vdc electromechanical gear motor.

**Reliable and silent:**

patented layout of internal parts, fewer moving parts.

**Easy to install:** after the gear motor has been assembled, all electrical connections are made from above.

**User-friendly release** with personalised Nice key or standard lock (optional).

**Pre-assembled,** travel stops on opening.

**Moonclever control unit MC424L:**

- simple programming, by means of a single key;
- clutch with anti-crush safety feature;
- automatic memorization of limit switches on opening and closing with self-learning function;
- programming of pause time;
- pedestrian pass door;
- deceleration on opening and closing;
- obstacle detection system;
- can be linked to the 8.2 KOhm resistive sensitive edge;
- continues to work even during power failures using optional (PS124) batteries that fit inside the control unit.

**NEW** The new Era Gate accessories, with a minimal, modern and discreet design, renovate Nice kits' style and performance.

Discover the complete range at page 184

CODE	DESCRIPTION	PACK/PALLET
WINGO5024KCE	KIT FOR SWING GATES WITH LEAVES UP TO 3.5 m, 24 Vdc, SURFACE MOUNTED	12

**N.B.** The content of the package may vary: consult the retailer.

**TECHNICAL SPECIFICATIONS**

CODE	WG5024
<b>ELECTRICAL DATA</b>	
POWER SUPPLY (Vdc)	24
ABSORPTION (A)	3.5
POWER (W)	85
<b>PERFORMANCE DATA</b>	
SPEED (m/s)	0.016
FORCE (N)	1500
WORK CYCLE (CYCLES/HOUR)	30
<b>DIMENSIONAL AND GENERAL DATA</b>	
PROTECTION LEVEL (IP)	44
WORKING TEMP. (°C MIN/MAX)	-20 ÷ +50
DIMENSIONS (mm)	920x98x95 h
WEIGHT (kg)	6

**UTILISATION LIMITS**

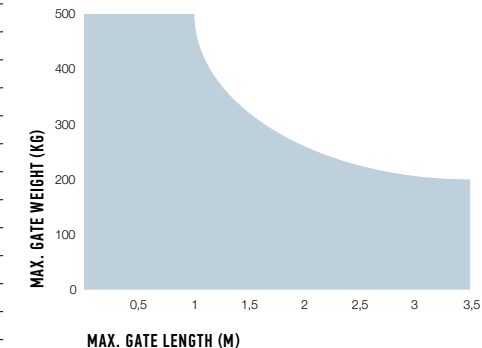

**DIMENSIONS**

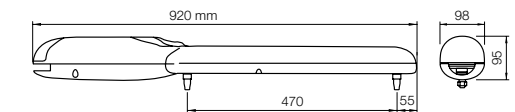

**THE KIT CONTAINS:**

**WG5024**  
2 SURFACE-MOUNTED ELECTROMECHANICAL GEAR MOTORS, WITH NICE KEY RELEASE AND MECHANICAL STOP ON OPENING.

**FL02RE**  
1 TRANSMITTER 433.92 MHz, 2 CHANNELS.

**MC424L**  
1 CONTROL UNIT WITH SMXI PLUG-IN RECEIVER.

**NEW**  
**EPM**  
1 PAIR OF PHOTOCELLS FOR OUTDOOR INSTALLATION.

**NEW**  
**EKS**  
1 KEY SELECTOR SWITCH FOR OUTDOOR INSTALLATION.

**NEW**  
**EL24**  
1 FLASHING LIGHT WITH INTEGRATED AERIAL.

**TS**  
1 SIGNBOARD.





## INSTALLATION DIAGRAM

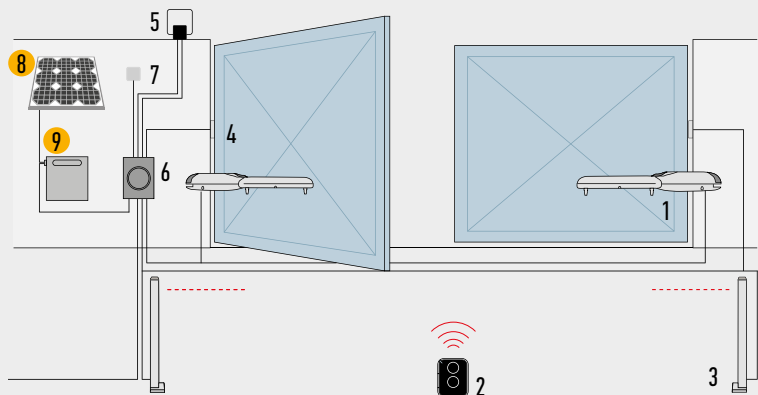

1. MOTOR
2. TRANSMITTER
3. PHOTOCELLS MOUNTED ON POSTS
4. PHOTOCELLS
5. FLASHING LIGHT
6. CONTROL UNIT
7. DIGITAL OR KEY SWITCHES
8. SYP SOLAR PANEL
9. PSY24 BATTERY BOX

● Solemyo SOLAR POWER ACCESSORIES

## ACCESSORIES



**PS124**  
24 V BATTERY  
WITH INTEGRATED  
BATTERY CHARGER.  
PC/PACK 1



**PLA6**  
REAR BRACKET  
250 mm LONG.  
PC/PACK 1



**PLA8**  
SCREW-ADJUSTABLE  
FRONT BRACKET.  
PC/PACK 1



**PLA10**  
VERTICAL 12 V ELECTRIC  
LOCK.  
PC/PACK 1



**PLA11**  
HORIZONTAL 12 V ELECTRIC  
LOCK.  
PC/PACK 1



**KIT SOLEMYO**  
THE SOLAR POWER TO  
AUTOMATE GATES, GARAGE  
DOORS OR BARRIER GATES.  
SEE PAGE 200

# WALKYKIT 1024

SOLEMYO OPERA BLUEBUS 24V

**For swing gates with leaves up to 1.8 m.**  
Especially suited to gates in wood or PVC.  
Irreversible electromechanical gear motor at 24 Vdc, with articulated arm.

**Ultra compact:** ideal for pedestrian gates, recommended for small posts (width 8 cm).

**Safe:** thanks to the irreversible motor and anti-shear arm with built-in mechanical stop on closure (with installation of entire arm).

**Practical:** the articulated arm enables installation in specific conditions, such as in the presence of small walls or obstacles adjacent to the post.

**Quick:** no waiting in front of the gate, just 7 seconds to open or close (in optimal installation conditions, with reduced arm and 90° opening).

**Convenient:** incorporable flashing LED indicator, with courtesy light function (WLT, optional); rapid motor release for manual movement of the gate.

**Built-in control unit:**

- simple programming;
- self-learning of opening and closing limit positions;
- automatic fault diagnostics;
- programming of pause time;
- pedestrian pass door;
- deceleration on opening and closing;
- provision for connection of latest generation resistive sensitive edges.

**No black out:** operation in the event of a power failure by means of optional batteries (PS424) housed inside the motor.

CODE	DESCRIPTION	PACK/PALLET
WALKY1024KCE	KIT FOR SWING GATES WITH LEAVES UP TO 1.8 m, 24 Vdc, SURFACE MOUNTED	18

**N.B.** The content of the package may vary; consult the retailer.

**TECHNICAL SPECIFICATIONS**

CODE	WL1024C
<b>ELECTRICAL DATA</b>	
POWER SUPPLY (Vac 50/60 Hz)	230
POWER SUPPLY (Vdc)	-
ABSORPTION (A)	0.8
POWER (W)	120
<b>PERFORMANCE DATA</b>	
SPEED (rpm)	1.5 - 2.2
TORQUE (Nm)	120
WORK CYCLE (CYCLES/HOUR)	50
<b>DIMENSIONAL AND GENERAL DATA</b>	
PROTECTION LEVEL (IP)	44
WORKING TEMP. (°C MIN/MAX)	-20° ÷ +50°
DIMENSIONS (mm)	90x125x385 h
WEIGHT (kg)	4,8

**DIMENSIONS**

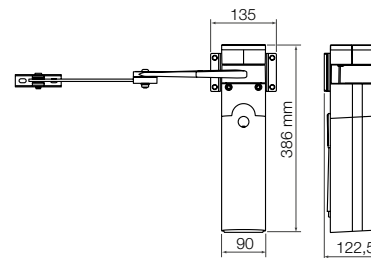

**UTILISATION LIMITS**

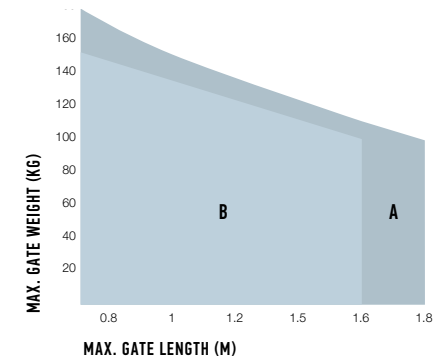
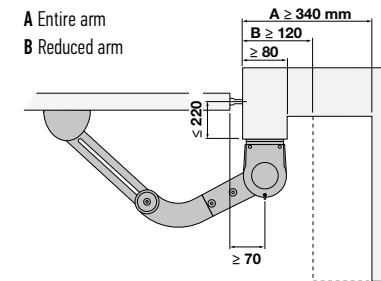

The shape, the height of the gate and the weather conditions can considerably reduce the values shown in the graph to the side.

**THE KIT CONTAINS:**



**WL1024C**  
1 ELECTROMECHANICAL GEAR MOTOR, SURFACE MOUNTED, WITH BUILT-IN CONTROL UNIT AND OXI PLUG-IN RECEIVER.

**ON2E**  
1 TRANSMITTER  
433.92 MHz, 2 CHANNELS.



**TS**  
1 SIGNBOARD.



## INSTALLATION DIAGRAM

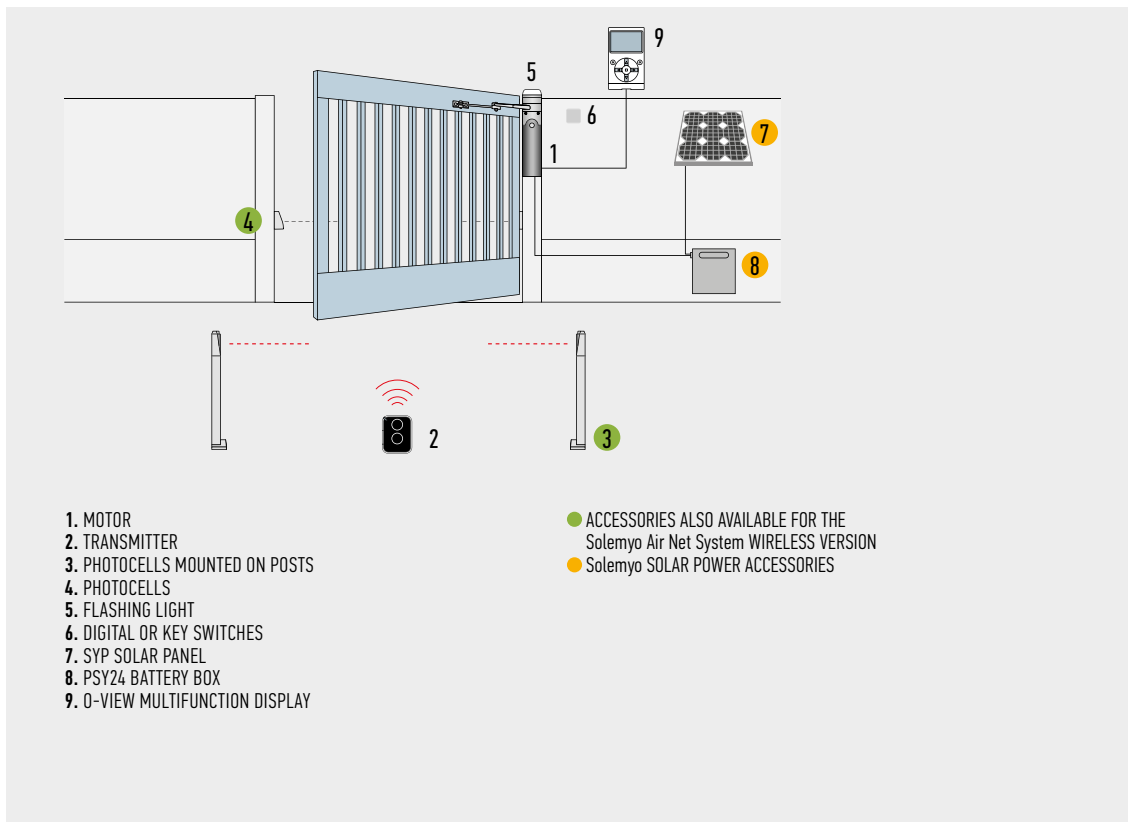

Nice recommends customers order products in pallets in order to facilitate storage and delivery, and ensure packs are uniform. The number of packs per single pallet has been specified for this reason. Approximate draft.

## ACCESSORIES



**WLA1**  
 SPARE CONTROL UNIT,  
 FOR WL1024C.



**PS424**  
 BUFFER BATTERY.  
 PC/PACK 1



**PLA10**  
 VERTICAL 12 V ELECTRIC  
 LOCK (REQUIRED FOR GATES  
 LONGER THAN 3 m).  
 PC/PACK 1



**PLA11**  
 HORIZONTAL 12 V ELECTRIC  
 LOCK (REQUIRED FOR GATES  
 LONGER THAN 3 m).  
 PC/PACK 1



**WLT**  
 MULTI-FUNCTION LED  
 INDICATOR.  
 SEE PAGE 199  
 PC/PACK 1



**KIT SOLEMYO**  
 THE SOLAR POWER TO  
 AUTOMATE GATES, GARAGE  
 DOORS OR BARRIER GATES.  
 SEE PAGE 200

FOR SWING GATES

FOR SLIDING GATES

BARRIER GATE  
 OPERATOR SYSTEMS

FOR GARAGE  
 AND INDUSTRIAL DOORS

CONTROL SYSTEMS  
 AND ACCESSORIES

COMPATIBILITY TABLE  
 AND ALPHABETICAL INDEX

# WALKYKIT 2024

SOLEMYO OPERA BLUEBUS 24V

**For swing gates with leaves up to 1.8 m.**  
Especially suited to gates in wood or PVC.  
Irreversible electromechanical gear motor at 24 Vdc, with articulated arm.

**Ultra compact:** ideal for pedestrian gates, recommended for small posts (width 8 cm).

**Safe:** thanks to the irreversible motor and anti-shear arm with built-in mechanical stop on closure (with installation of entire arm).

**Practical:** the articulated arm enables installation in specific conditions, such as in the presence of small walls or obstacles adjacent to the post.

**Quick:** no waiting in front of the gate, just 7 seconds to open or close (in optimal installation conditions, with reduced arm and 90° opening).

**Convenient:** incorporable flashing LED indicator, with courtesy light function (WLT, optional); rapid motor release for manual movement of the gate.

**Built-in control unit:**

- simple programming;
- self-learning of opening and closing limit positions;
- automatic fault diagnostics;
- programming of pause time;
- pedestrian pass door;
- deceleration on opening and closing;
- provision for connection of latest generation resistive sensitive edges.

**No black out:** operation in the event of a power failure by means of optional batteries (PS424) housed inside the motor.

**NEW** The new Era Gate accessories, with a minimal, modern and discreet design, renovate Nice kits' style and performance.

Discover the complete range at page 184

CODE	DESCRIPTION	PACK/PALLET
WALKY2024KCE	KIT FOR SWING GATES WITH LEAVES UP TO 1.8 m, 24 Vdc, WITH ARTICULATED ARM, SURFACE MOUNTED	18

**N.B.** The content of the package may vary: consult the retailer.

**TECHNICAL SPECIFICATIONS**

CODE	WL1024C	WL1024
<b>ELECTRICAL DATA</b>		
POWER SUPPLY (Vac 50/60 Hz)	230	-
POWER SUPPLY (Vdc)	-	24
ABSORPTION (A)	0.8	2
POWER (W)	120	30
<b>PERFORMANCE DATA</b>		
SPEED (rpm)	1.5 - 2.2	
TORQUE (Nm)	120	
WORK CYCLE (CYCLES/HOUR)	50	
<b>DIMENSIONAL AND GENERAL DATA</b>		
PROTECTION LEVEL (IP)	44	
WORKING TEMP. (°C MIN/MAX)	-20° ÷ +50°	
DIMENSIONS (mm)	90x125x385 h	
WEIGHT (kg)	4,8	4,3

**DIMENSIONS**

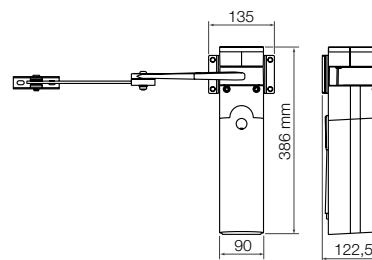

**UTILISATION LIMITS**

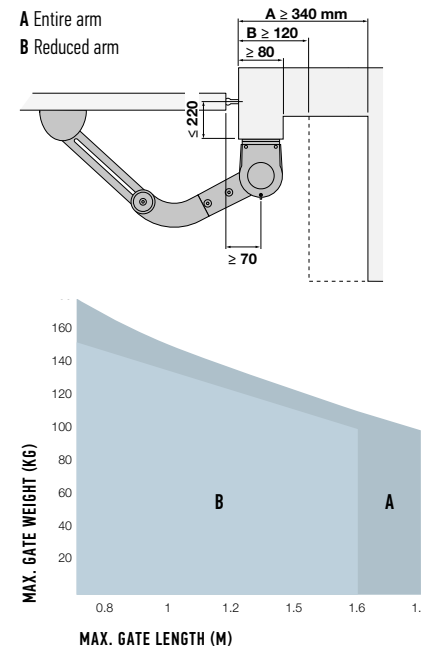

The shape, the height of the gate and the weather conditions can considerably reduce the values shown in the graph to the side.

**THE KIT CONTAINS:**

**WL1024C + WL1024**  
2 ELECTROMECHANICAL GEAR MOTORS, SURFACE MOUNTED.  
WL1024C (WITH CONTROL UNIT AND OXI PLUG-IN RECEIVER), WL1024 (WITHOUT CONTROL UNIT).



**ON2E**  
1 TRANSMITTER  
433.92 MHz, 2 CHANNELS.



**NEW**

**EPMB**  
1 COUPLE OF EXTERNAL PHOTOCELLS DESIGNED FOR CONNECTION BY NICE BLUEBUS.



**NEW**

**EKS**  
1 KEY SELECTOR SWITCH FOR OUTDOOR INSTALLATION.



**WLT**  
1 FLASHING LIGHT.



**TS**  
1 SIGNBOARD.



## INSTALLATION DIAGRAM



Nice recommends customers order products in pallets in order to facilitate storage and delivery, and ensure packs are uniform. The number of packs per single pallet has been specified for this reason. Approximate draft.

## ACCESSORIES



**WLA1**  
 SPARE CONTROL UNIT,  
 FOR WL1024C.



**PS424**  
 BUFFER BATTERY.  
 PC/PACK 1



**PLA10**  
 VERTICAL 12 V ELECTRIC  
 LOCK (REQUIRED FOR GATES  
 LONGER THAN 3 m).  
 PC/PACK 1



**PLA11**  
 HORIZONTAL 12 V ELECTRIC  
 LOCK (REQUIRED FOR GATES  
 LONGER THAN 3 m).  
 PC/PACK 1



**WLT**  
 MULTI-FUNCTION LED  
 INDICATOR.  
 SEE PAGE 199  
 PC/PACK 1



**KIT SOLEMYO**  
 THE SOLAR POWER TO  
 AUTOMATE GATES, GARAGE  
 DOORS OR BARRIER GATES.  
 SEE PAGE 200

FOR SWING GATES

FOR SLIDING GATES

BARRIER GATE  
 OPERATOR SYSTEMS

FOR GARAGE  
 AND INDUSTRIAL DOORS

CONTROL SYSTEMS  
 AND ACCESSORIES

COMPATIBILITY TABLE  
 AND ALPHABETICAL INDEX

# HOPP

SOLEMYO OPERA BLUEBUS 24V

## For swing gates with leaves up to 2.4 m, ideal for large columns.

Irreversible electromechanical 24 Vdc gear motor with articulated arm, surface mounted. Ideal for intensive use.

**Two irreversible 24 Vdc versions** with micrometric adjustment mechanical stops on opening and closing: with built-in control unit (H07124) and without control unit (H07224).

**Powerful** thanks to the 250 Nm torque.

**Resistant and compact:** 180 mm in width, ideal for any kind of post. Small shockproof body with aluminium base.

**Sturdy, aluminium anti-shearing arm.**

**Easy to install:** thanks to the new fixing bracket with quick connector for the motor. No welding.

**Sophisticated electronics with the built-in control unit,** just 3 keys to manage all programming operations:

- obstacle detection and possibility of connecting to 8.2 KOhm sensitive edge, fototest;
- automatic fault diagnostics;
- memorisation of opening and closing travel limits in self-learning mode;
- possibility of configuring the stop input in self-learning mode, NO, NC and the latest generation 8.2 KOhm resistive sensitive edges;
- deceleration on opening and closing;
- simple connection of pairs of additional photocells, foto2;
- programming of pause time;
- pedestrian open and partial open;
- clutch with anti-crushing safety mechanism.

**Energy saving with no black outs:**

3 standby modes to reduce mains consumption, or battery power consumption if connected to the Solemyo kit. Operation in the event of a power failure thanks to the optional batteries (PS124).

**Everything under control:** thanks to compatibility for operation with Opera system BUS T4, the unit can be used to expand the options of programming, control and diagnostics of the automation on site and remotely.

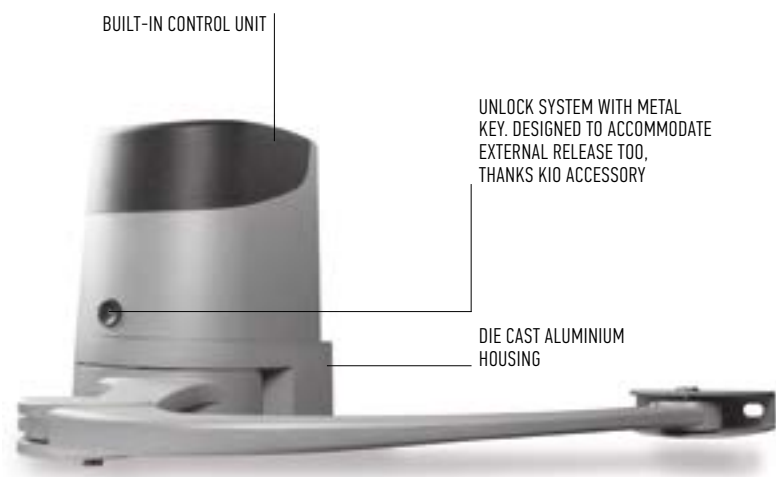

CODE	DESCRIPTION	PACK/PALLET
H07124	IRREVERSIBLE 24 Vdc, COMPLETE WITH ARTICULATED ARM AND BUILT-IN CONTROL UNIT	12
H07224	IRREVERSIBLE 24 Vdc, COMPLETE WITH ARTICULATED ARM WITHOUT CONTROL UNIT	12

**N.B.** The content of the package may vary: consult the retailer.

## TECHNICAL SPECIFICATIONS

CODE	H07124	H07224
<b>ELECTRICAL DATA</b>		
POWER SUPPLY (Vac 50/60 Hz)	230	-
POWER SUPPLY (Vdc)	-	24
ABSORPTION (A)	1.3	4
POWER (W)	280	100
<b>PERFORMANCE DATA</b>		
SPEED (rpm)	1.68	
TORQUE (Nm)	250	
WORK CYCLE (CYCLES/HOUR)	35	
<b>DIMENSIONAL AND GENERAL DATA</b>		
PROTECTION LEVEL (IP)	54	
WORKING TEMP. (°C MIN/MAX)	-20 ÷ +50	
DIMENSIONS (mm)	252x180x290 h	
WEIGHT (kg)	9	6.5

\* Version without control unit, only if associated with PP7124

## UTILISATION LIMITS

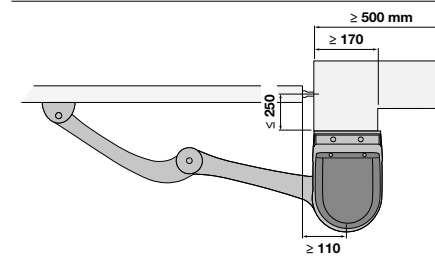

## DIMENSIONS

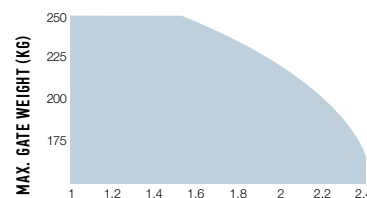
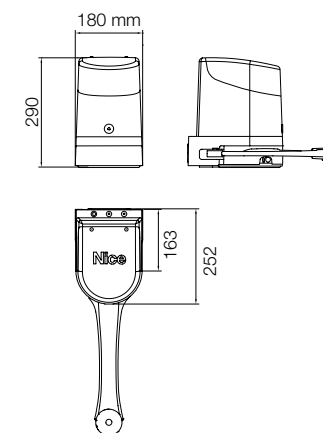

## MAX. GATE LENGTH (M)

The shape, the height of the gate and the weather conditions can considerably reduce the values shown in the graph to the side.

## INSTALLATION DIAGRAM

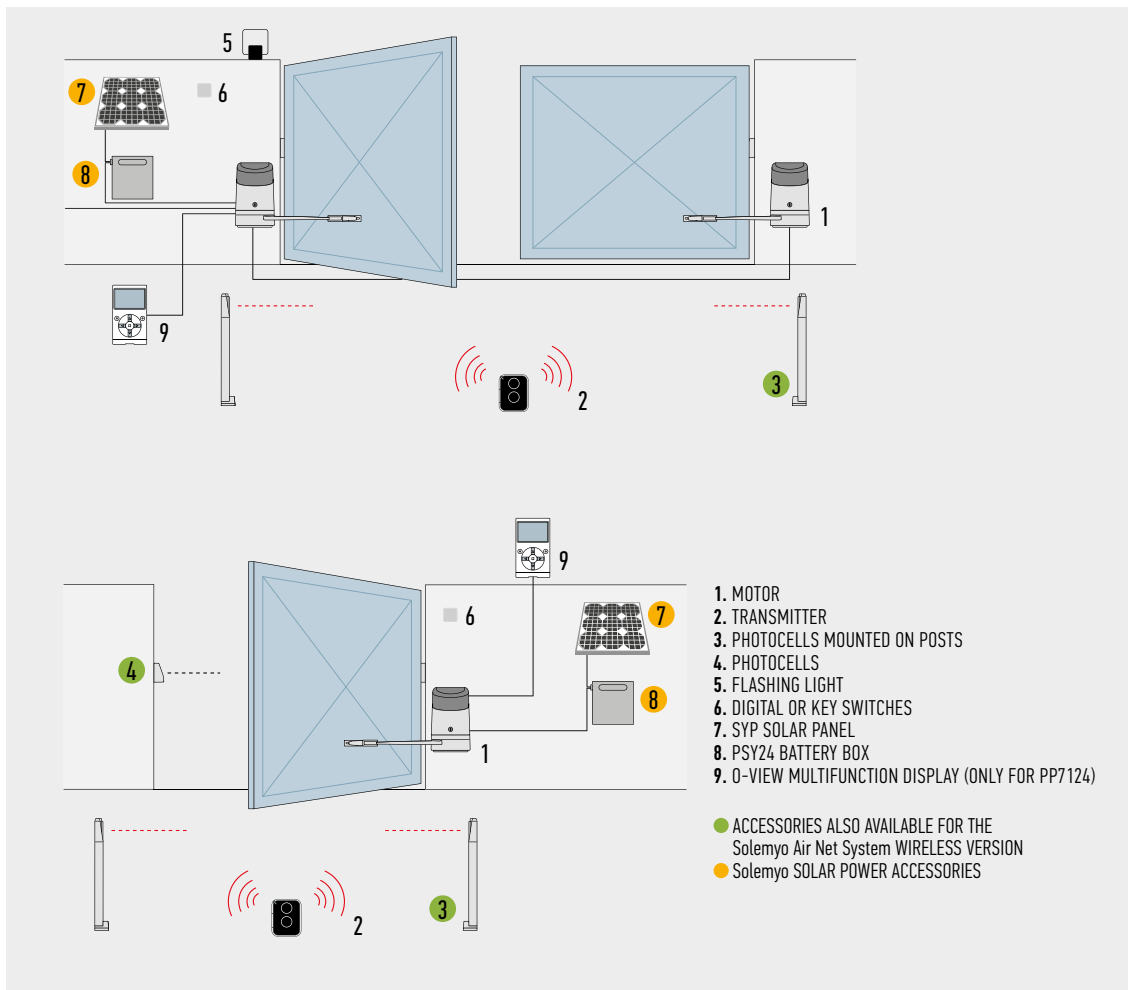

## COMPATIBILITY TABLE WITH CONTROL SYSTEMS AND ACCESSORIES

CODE	RECEIVER		TRANSMITTER				PHOTOCELLS								FLASHING LIGHT						
	Built-in*	FLOX12R*	OXI	ERA INTI	ERA ONE	ERA FLOR	NICEMWAY	EPS	EPM	EPL	EPSB	EPMB	EPLB	F210	FT210	F210B	FT210B	EL	EL24	ELB	WLT
<b>H07124</b>			●	●	●	●	●				●	●	●			●				●	●

\*Radio receiver incompatible with Opera system

## ACCESSORIES



**POA3**  
SPARE CONTROL UNIT FOR H07174.



**PS124**  
24 V BATTERY WITH INTEGRATED BATTERY CHARGER.  
PC/PACK 1



**PLA10**  
VERTICAL 12 V ELECTRIC LOCK (REQUIRED FOR GATES LONGER THAN 3 m).  
PC/PACK 1



**PLA11**  
HORIZONTAL 12 V ELECTRIC LOCK (REQUIRED FOR GATES LONGER THAN 3 m).  
PC/PACK 1



**KIO**  
KEY-OPERATED SELECTOR SWITCH FOR LOW VOLTAGE CONTACTS, WITH RELEASE MECHANISM FOR METAL CORD.  
PC/PACK 1



**KA1**  
6 m CABLE RELEASE KIT FOR KIO.  
PC/PACK 1



**TS**  
SIGNBOARD.  
PC/PACK 1



**KIT SOLEMYO**  
THE SOLAR POWER TO AUTOMATE GATES, GARAGE DOORS OR BARRIER GATES. SEE PAGE 200

FOR SWING GATES

FOR SLIDING GATES

BARRIER GATE OPERATOR SYSTEMS

FOR GARAGE AND INDUSTRIAL DOORS

CONTROL SYSTEMS AND ACCESSORIES

COMPATIBILITY TABLE AND ALPHABETICAL INDEX

# HOPPKIT

SOLEMYO OPERA BLUEBUS 24V

**For swing gates with leaves up to 2.4 m, ideal for large columns.**

Irreversible electromechanical 24 Vdc gear motor with articulated arm, surface mounted. Ideal for intensive use.

**Two irreversible 24 Vdc versions** with micrometric adjustment mechanical stops on opening and closing: with built-in control unit (H07124) and without control unit (H07224).

**Powerful** thanks to the 250 Nm torque.

**Resistant and compact:** 180 mm in width, ideal for any kind of post. Small shockproof body with aluminium base.

**Sturdy, aluminium anti-shearing arm.**

**Easy to install:** thanks to the new fixing bracket with quick connector for the motor. No welding.

- Sophisticated electronics with the built-in control unit,** just 3 keys to manage all programming operations:
- obstacle detection and possibility of connecting to 8.2 KOhm sensitive edge, fototest;
  - automatic fault diagnostics;
  - memorisation of opening and closing travel limits in self-learning mode;
  - possibility of configuring the stop input in self-learning mode, NO, NC and the latest generation 8.2 KOhm resistive sensitive edges;
  - deceleration on opening and closing;
  - simple connection of pairs of additional photocells, foto2;
  - programming of pause time;
  - pedestrian open and partial open;
  - clutch with anti-crushing safety mechanism.

**Energy saving with no black outs:**  
3 standby modes to reduce mains consumption, or battery power consumption if connected to the Solemyo kit. Operation in the event of a power failure thanks to the optional batteries (PS124).

**Everything under control: thanks to compatibility for operation with Opera system BUS T4, the unit can be used** to expand the options of programming, control and diagnostics of the automation on site and remotely.

**NEW** The new Era Gate accessories, with a minimal, modern and discreet design, renovate Nice kits' style and performance. Discover the complete range at page 184

## THE KIT CONTAINS:

**H07124 + H07224,** 2 SURFACE-MOUNTED ELECTROMECHANICAL GEAR MOTORS: H07124 (WITH CONTROL UNIT AND OXI PLUG-IN RECEIVER), H07224 (WITHOUT CONTROL UNIT).



**ON2E**  
1 TRANSMITTER 433.92 MHz,  
2 CHANNELS.



**NEW**  
**EPMB**  
1 COUPLE OF EXTERNAL  
PHOTOCELLS DESIGNED  
FOR CONNECTION BY NICE  
BLUEBUS.



**NEW**  
**ELB**  
1 FLASHING LIGHT WITH  
INTEGRATED AERIAL.



CODE	DESCRIPTION	PACK/PALLET
HOPPKCE	KIT FOR THE AUTOMATION OF SWING GATES WITH LEAVES UP TO 2.4 m, 24 Vdc, EXTERNALLY MOUNTED	12

**N.B.** The content of the package may vary: consult the retailer.

## TECHNICAL SPECIFICATIONS

CODE	H07124	H07224
<b>ELECTRICAL DATA</b>		
POWER SUPPLY (Vac 50/60 Hz)	230	-
POWER SUPPLY (Vdc)	-	24
ABSORPTION (A)	1.3	4
POWER (W)	280	100
<b>PERFORMANCE DATA</b>		
SPEED (rpm)	1.68	
TORQUE (Nm)	250	
WORK CYCLE (CYCLES/HOUR)	35	
<b>DIMENSIONAL AND GENERAL DATA</b>		
PROTECTION LEVEL (IP)	54	
WORKING TEMP. (°C MIN/MAX)	-20 ÷ +50	
DIMENSIONS (mm)	252x180x290 h	
WEIGHT (kg)	9	6.5

\* Version without control unit, only if associated with PP7124

## DIMENSIONS

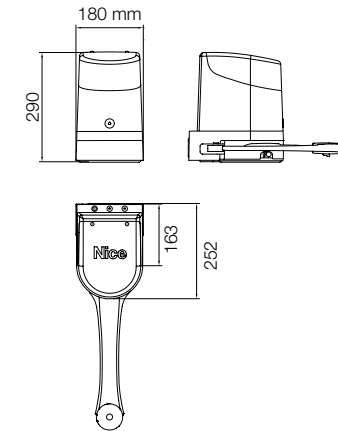

## UTILISATION LIMITS

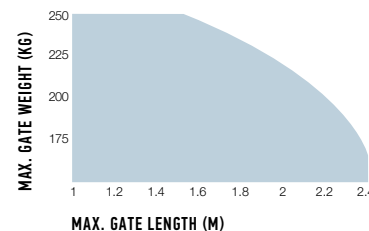

The shape, the height of the gate and the weather conditions can considerably reduce the values shown in the graph to the side.

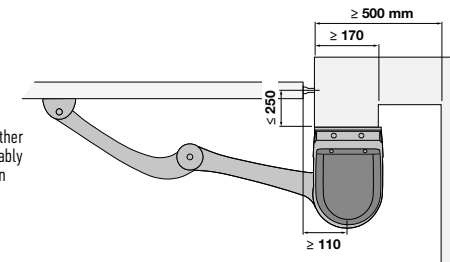



## INSTALLATION DIAGRAM

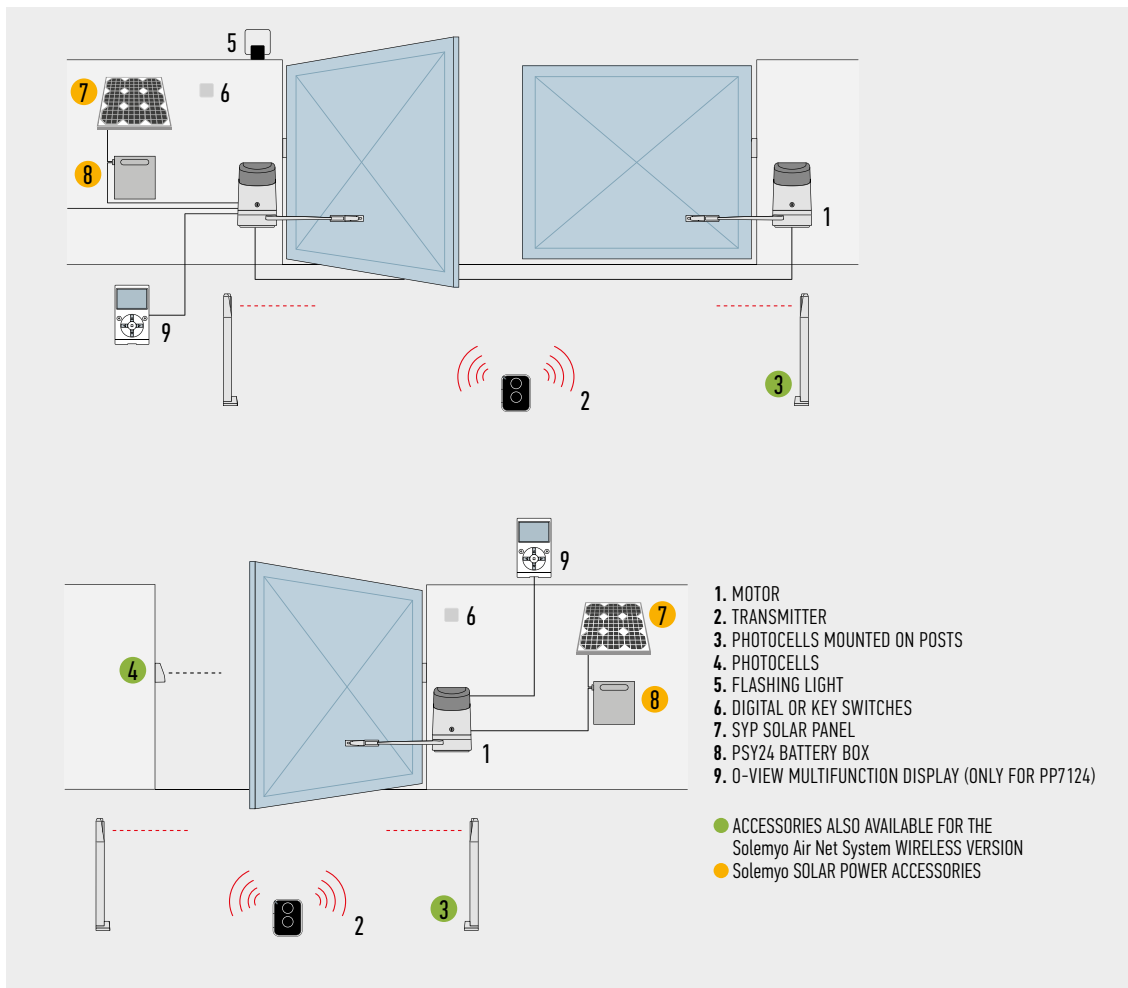

## ACCESSORIES



**POA3**  
SPARE CONTROL UNIT FOR H07174.



**PS124**  
24 V BATTERY WITH INTEGRATED BATTERY CHARGER.

PC/PACK 1



**PLA10**  
VERTICAL 12 V ELECTRIC LOCK (REQUIRED FOR GATES LONGER THAN 3 m).

PC/PACK 1



**PLA11**  
HORIZONTAL 12 V ELECTRIC LOCK (REQUIRED FOR GATES LONGER THAN 3 m).

PC/PACK 1



**KIO**  
KEY-OPERATED SELECTOR SWITCH FOR LOW VOLTAGE CONTACTS, WITH RELEASE MECHANISM FOR METAL CORD.

PC/PACK 1



**KA1**  
6 m CABLE RELEASE KIT FOR KIO.

PC/PACK 1



**TS**  
SIGNBOARD.

PC/PACK 1



**KIT SOLEMYO**  
THE SOLAR POWER TO AUTOMATE GATES, GARAGE DOORS OR BARRIER GATES. SEE PAGE 200

## For swing gates with leaves up to 3.5 m, ideal for large columns.

Irreversible electromechanical 24 Vdc gearmotor with articulated arm, surface mounted. Ideal for intensive use.

**Reliable**, durability thanks to the housing in aluminium with polyester paint finish, resistant to atmospheric agents.

**Ultra-powerful and delicate**: thanks to the torque of 500 Nm and encoder technology, for millimetric precision and reliability. Safety in movement with dual technology obstacle detection.



Adjustable anti-crushing arm

ADJUSTABLE ANTI-CRUSHING ARM



**Two irreversible 24 Vdc versions** with limit switches on opening and closing: with built-in control unit (HK7024) and without control unit (HK7224).

**Practical and quick installation:** the articulated arm is adjustable in length for maximum flexibility.

**Simple and precise limit switch adjustment:** mechanical stops and micrometric adjustment screws.

**Easy to operate release lever**, with metal lock and personalised Nice key. With provision for cable control.

**Savings, respect for the environment, and autonomy:** when connected to the buffer battery or Solemyo kit, consumption on standby is just 0.1 W.

**No black out:** with the optional batteries (PS124) housed inside the gear motor.

### Built-in control unit (HK7024):

- simple programming via a single key;
- self-learning of opening and closing limit positions;
- automatic fault diagnostics;
- pause time programming;
- pass door;
- deceleration on opening and closing;
- obstacle detection with dual technology;
- provision for connection of latest generation sensitive edges.

CODE	DESCRIPTION	PACK/PALLET
HK7024	IRREVERSIBLE 24 Vdc, COMPLETE WITH ARTICULATED ARM AND BUILT-IN CONTROL UNIT	12
HK7224	IRREVERSIBLE 24 Vdc, COMPLETE WITH ARTICULATED ARM WITHOUT CONTROL UNIT	12

### TECHNICAL SPECIFICATIONS

CODE	HK7024	HK7224
<b>ELECTRICAL DATA</b>		
POWER SUPPLY (Vac 50/60 Hz)	230	-
POWER SUPPLY (Vdc)	-	24
ABSORPTION (A)	1.5	6
POWER (W)	300	140
<b>PERFORMANCE DATA</b>		
SPEED (rpm)	1.5	
TORQUE (Nm)	500	
WORK CYCLE (CYCLES/HOUR)	40	
<b>DIMENSIONAL AND GENERAL DATA</b>		
PROTECTION LEVEL (IP)	54	
WORKING TEMP. (°C MIN/MAX)	-20 ÷ +50	
DIMENSIONS (mm)	290x210x320 h	
WEIGHT (kg)	10.5	9.5

### UTILISATION LIMITS

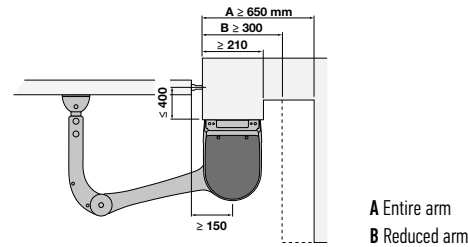

A Entire arm  
B Reduced arm

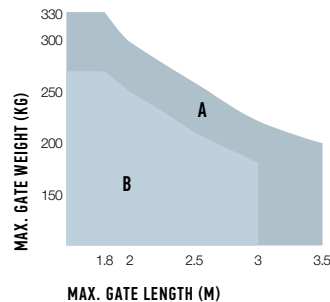

The shape, the height of the gate and the weather conditions can considerably reduce the values shown in the graph to the side.

### DIMENSIONS

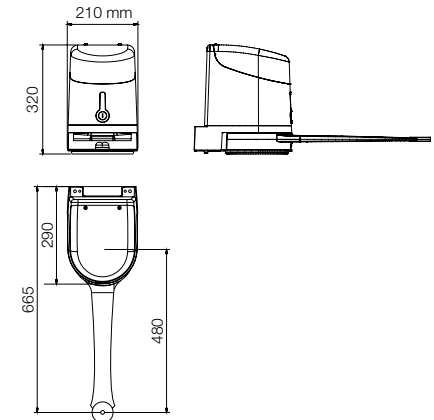

## INSTALLATION DIAGRAM

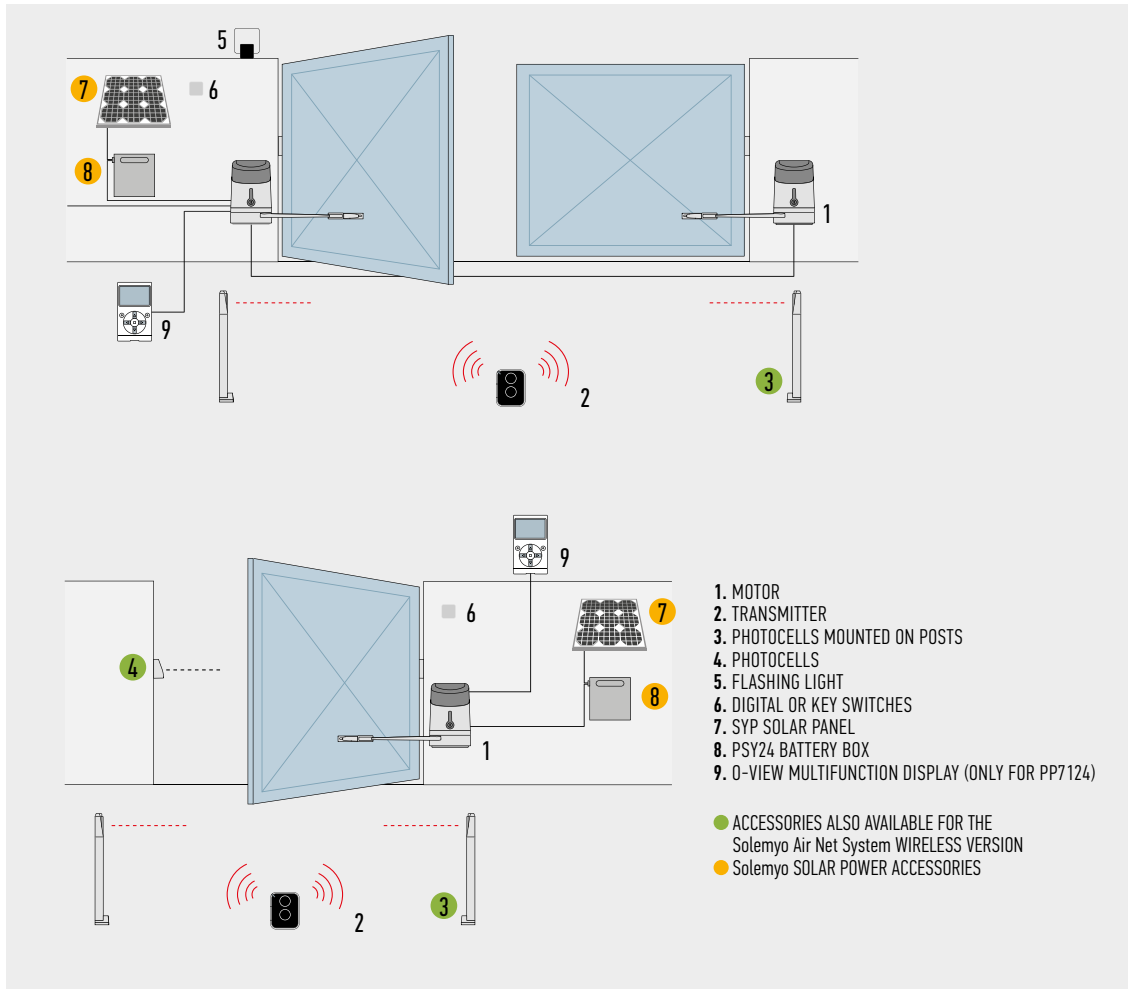

## COMPATIBILITY

CODE

HK7024

RECEIVER	TRANSMITTER	PHOTOCELLS								FLASHING LIGHT										
Built-in*	FLOX2R*	OXI	ERA INTI	ERA ONE	ERA FLOR	NICEWAY	EPS	EPM	EPL	EPSB	EPMB	EPLB	F210	FT210	F210B	FT210B	EL	EL24	ELB	WLT
		●	●	●	●	●				●	●	●			●				●	●

\*Radio receiver incompatible with Opera system

## ACCESSORIES



**HKA1**  
SPARE CONTROL UNIT FOR HK7024.



**PS124**  
24 V BATTERY WITH INTEGRATED BATTERY CHARGER.

PC/PACK 1



**PLA10**  
VERTICAL 12 V ELECTRIC LOCK (REQUIRED FOR GATES LONGER THAN 3 m).

PC/PACK 1



**PLA11**  
HORIZONTAL 12 V ELECTRIC LOCK (REQUIRED FOR GATES LONGER THAN 3 m).

PC/PACK 1



**KIO**  
KEY-OPERATED SELECTOR SWITCH FOR LOW VOLTAGE CONTACTS, WITH RELEASE MECHANISM FOR METAL CORD.

PC/PACK 1



**KA1**  
6 m CABLE RELEASE KIT FOR KIO.

PC/PACK 1



**TS**  
SIGNBOARD.

PC/PACK 1



### KIT SOLEMYO

THE SOLAR POWER TO AUTOMATE GATES, GARAGE DOORS OR BARRIER GATES. SEE PAGE 200

# HYKEKIT

SOLEMYO OPERA BLUEBUS 24V

## For swing gates with leaves up to 3.5 m, ideal for large columns.

Irreversible electromechanical 24 Vdc gear motor with articulated arm, surface mounted. Ideal for intensive use.

**Quality and durability** thanks to the housing in aluminium with polyester paint finish, resistant to atmospheric agents.

**Ultra-powerful and delicate:** thanks to the torque of 500 Nm and encoder technology, for millimetric precision and reliability. Safety in movement with dual technology obstacle detection.

**Two irreversible 24 Vdc versions** with limit switches on opening and closing: with built-in control unit (HK7024) and without control unit (HK7224).



Adjustable anti-crushing arm

**Practical and quick installation:** the articulated arm is adjustable in length for maximum flexibility.

**Simple and precise limit switch adjustment:** mechanical stops and micrometric adjustment screws.

**Easy to operate release lever,** with metal lock and personalised Nice key. With provision for cable control.

**Savings, respect for the environment, and autonomy:** when connected to the buffer battery or Solemyo kit, consumption on standby is just 0.1 W.

**No black out:** with the optional batteries (PS124) housed inside the gear motor.

### Built-in control unit (HK7024):

- simple programming via a single key;
- self-learning of opening and closing limit positions;
- automatic fault diagnostics;
- pause time programming;
- pass door;
- deceleration on opening and closing;
- obstacle detection with dual technology;
- provision for connection of latest generation sensitive edges.

**NEW** The new Era Gate accessories, with a minimal, modern and discreet design, renovate Nice kits' style and performance.

Discover the complete range at page 184

CODE	DESCRIPTION	PACK/PALLET
HYKEKCE	KIT FOR THE AUTOMATION OF SWING GATES WITH LEAVES UP TO 3.5 m, 24 Vdc, WITH ARTICULATED ARM, EXTERNALLY MOUNTED	12

**N.B.** The content of the package may vary: consult the retailer.

## TECHNICAL SPECIFICATIONS

CODE	HK7024	HK7224
<b>ELECTRICAL DATA</b>		
POWER SUPPLY (Vac 50/60 Hz)	230	-
POWER SUPPLY (Vdc)	-	24
ABSORPTION (A)	1.5	6
POWER (W)	300	140
<b>PERFORMANCE DATA</b>		
SPEED (rpm)	1.5	
TORQUE (Nm)	500	
WORK CYCLE (CYCLES/HOUR)	40	
<b>DIMENSIONAL AND GENERAL DATA</b>		
PROTECTION LEVEL (IP)	54	
WORKING TEMP. (°C MIN/MAX)	-20 ÷ +50	
DIMENSIONS (mm)	290x210x320 h	
WEIGHT (kg)	10,5	9,5

## DIMENSIONS

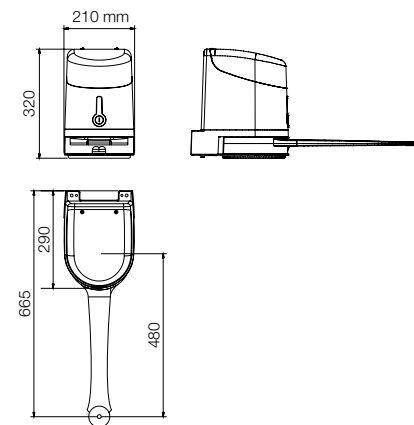

## UTILISATION LIMITS

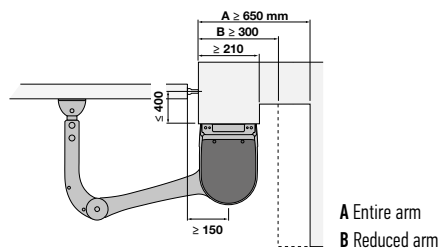

A Entire arm  
B Reduced arm

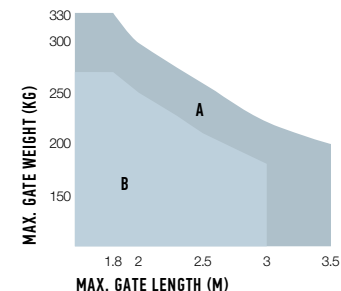

The shape, the height of the gate and the weather conditions can considerably reduce the values shown in the graph to the side.

## THE KIT CONTAINS:

**HK7024 + HK7224**  
ELECTROMECHANICAL GEAR MOTORS FOR EXTERNAL MOUNTING. HK7024 (WITH CONTROL UNIT AND SNAP-FIT RECEIVER OXI), HK7224 (WITHOUT CONTROL UNIT).



**ON2E**  
1 TRANSMITTER 433.92 MHz, 2 CHANNELS.



**NEW**  
**EPMB**  
1 COUPLE OF EXTERNAL PHOTOCELLS DESIGNED FOR CONNECTION BY NICE BLUEBUS.



**NEW**  
**ELB**  
1 FLASHING LIGHT WITH INTEGRATED AERIAL.



## INSTALLATION DIAGRAM

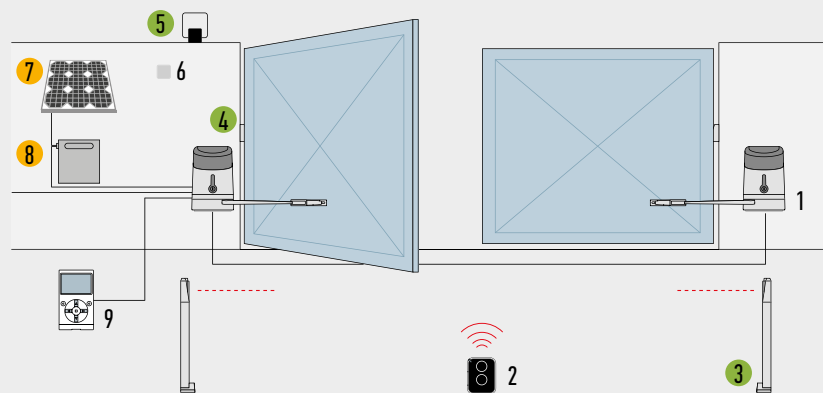

1. MOTOR
2. TRANSMITTER
3. PHOTOCELLS MOUNTED ON POSTS
4. PHOTOCELLS
5. FLASHING LIGHT
6. DIGITAL OR KEY SWITCHES
7. SYP SOLAR PANEL
8. PSY24 BATTERY BOX
9. O-VIEW MULTIFUNCTION DISPLAY

- ACCESSORIES ALSO AVAILABLE FOR THE Solemyo Air Net System WIRELESS VERSION
- Solemyo SOLAR POWER ACCESSORIES

## ACCESSORIES



**HKA1**  
SPARE CONTROL UNIT FOR HK7024.



**PS124**  
24 V BATTERY WITH INTEGRATED BATTERY CHARGER.

PC/PACK 1



**PLA10**  
VERTICAL 12 V ELECTRIC LOCK (REQUIRED FOR GATES LONGER THAN 3 m).

PC/PACK 1



**PLA11**  
HORIZONTAL 12 V ELECTRIC LOCK (REQUIRED FOR GATES LONGER THAN 3 m).

PC/PACK 1



**KIO**  
KEY-OPERATED SELECTOR SWITCH FOR LOW VOLTAGE CONTACTS, WITH RELEASE MECHANISM FOR METAL CORD.

PC/PACK 1



**KA1**  
6 m CABLE RELEASE KIT FOR KIO.

PC/PACK 1



**TS**  
SIGNBOARD.

PC/PACK 1



**KIT SOLEMYO**  
THE SOLAR POWER TO AUTOMATE GATES, GARAGE DOORS OR BARRIER GATES. SEE PAGE 200

FOR SWING GATES

FOR SLIDING GATES

BARRIER GATE OPERATOR SYSTEMS

FOR GARAGE AND INDUSTRIAL DOORS

CONTROL SYSTEMS AND ACCESSORIES

COMPATIBILITY TABLE AND ALPHABETICAL INDEX

# HYPPO 7000

SOLEMYO OPERA BLUEBUS 24V 230V

**For swing gates with leaves up to 3 m, also ideal for large pillars.**

Electromechanical gear motor, surface mounted, also in 24 Vdc version with magnetic encoder, with articulated arm.

Single model for right and left leaves.

Two irreversible versions, with 230 Vac (HY7005) and 24 Vdc (HY7024) power supplies with magnetic encoder.

Fewer connections mean **quicker installation.**

**Pre-wired, incorporated double limit-switch** both during opening and closing (HY7005).

**Easy and quick to install:** thanks to fewer connections and nothing welded to the gates.

**Long-lasting:** solid metal mechanics.

**Compact:** shockproof bodywork with no sharp corners.

### Recommended control units:

Mindy A6F, A60, A700F;  
for HY7024 Moonclever MC824H.

**24 Vdc version** with magnetic encoder.

**Perfect for intensive use,** compatible with the control unit Moonclever MC824H:

- simple programming, by means of a single key;
- self-learning of opening and closing limit positions;
- automatic fault diagnostics;
- programming of pause time;
- pedestrian pass door;
- deceleration on opening and closing;
- obstacle detection with dual technology;
- operation in event of power failure by means of optional rechargeable batteries (PS324);
- provision for connection of latest generation resistive sensitive edges.



DIE-CAST, ALUMINIUM, KEY-OPERATED UNLOCK SYSTEM, COMPLETE WITH PROTECTED KEY. DESIGNED TO ACCOMMODATE EXTERNAL RELEASE, TOO

STURDY, ANTI-SHEARING ARM, GALVANISED AND PAINTED; STRENGTHENED IN THOSE AREAS SUBJECTED TO GREATER MECHANICAL STRESS

CODE	DESCRIPTION	PACK/PALLET
HY7024	IRREVERSIBLE, 24 Vdc, WITH MAGNETIC ENCODER, WITH SHEAR-PROOF ARTICULATED ARM, GALVANIZED AND PAINTED	16
HY7005	IRREVERSIBLE, 230 Vac, WITH STURDY ARTICULATED SHEAR-PROOF ARM, GALVANIZED AND PAINTED, WITH LIMIT SWITCH ON OPENING AND CLOSING	16

### TECHNICAL SPECIFICATIONS

CODE	HY7024	HY7005
<b>ELECTRICAL DATA</b>		
POWER SUPPLY (Vac 50 Hz)*	-	230
POWER SUPPLY (Vdc)	24	-
ABSORPTION (A)	5	1.2
POWER (W)	120	250
<b>PERFORMANCE DATA</b>		
SPEED (rpm)	2	1.7
TORQUE (Nm)	250	400
WORK CYCLE (%)	80	30
<b>DIMENSIONAL AND GENERAL DATA</b>		
PROTECTION LEVEL (IP)	43	
WORKING TEMP. (°C MIN/MAX)	-20 ÷ +50	
DIMENSIONS (mm)	350x165x242 h	
WEIGHT (kg)	13	

\*60 Hz version available on request.

### UTILISATION LIMITS

- A Standard arm
- B Arm with accessory HYA12

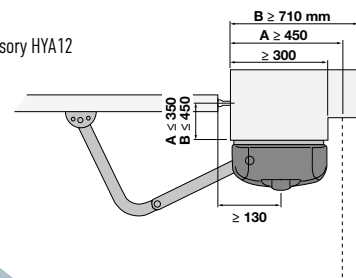

### DIMENSIONS

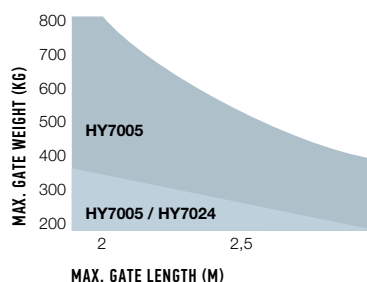
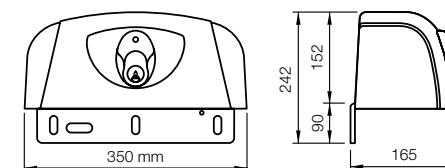

N.B. The above values are valid if the motor is used with standard accessories. The shape, the height of the gate and the weather conditions can considerably reduce the values shown in the graph to the side. Use in windy areas 230 Vac models.

## INSTALLATION DIAGRAM

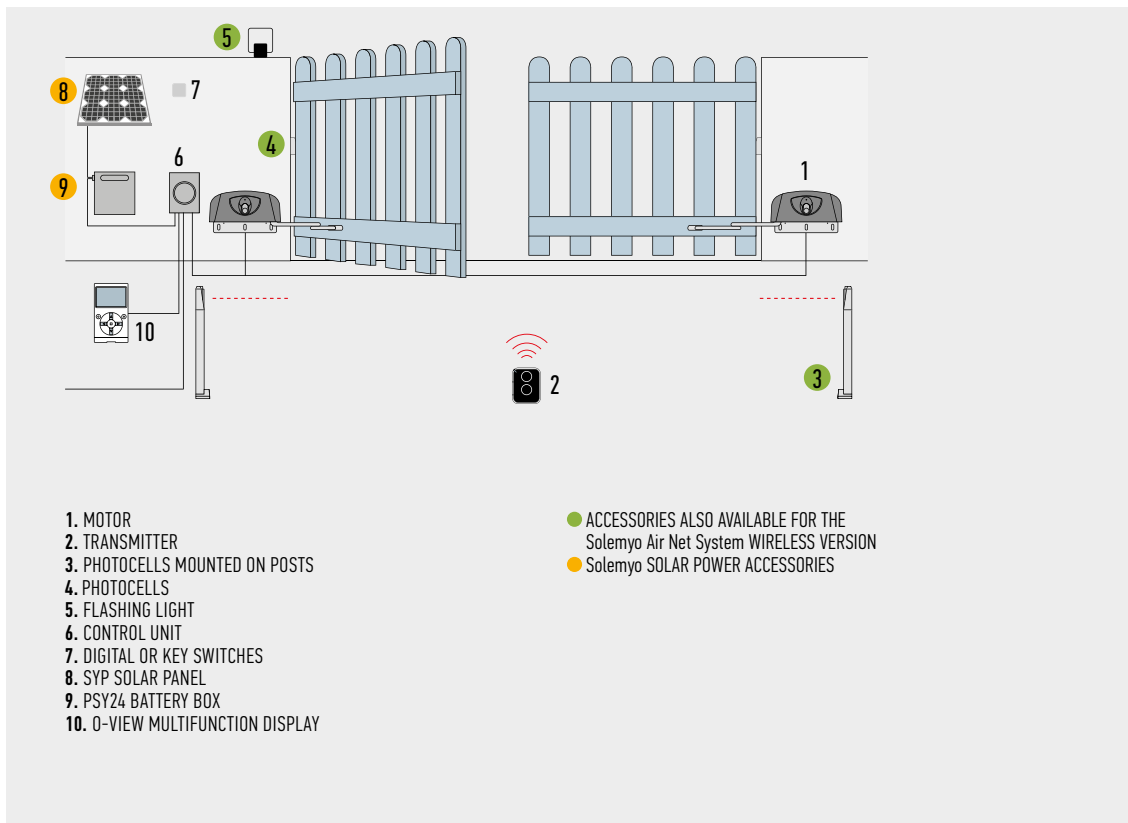

## COMPATIBILITY TABLE WITH CONTROL SYSTEMS AND ACCESSORIES

CODE	CONTROL UNIT / RECEIVER										TRANSMITTER				PHOTOCELLS						FLASHING LIGHT							
	A01 / Built-in*	A02 / Built-in*	A6F / FLOX12R*	A700F / FLOX12R*	A60 / OXI-SMXI*	A500 / FLOX12R*	A924 / FLOX12R*	MC424L / OXI	MC824H / OXI	MC824HR / OXI	ERA INTI	ERA ONE	ERA FLOR	NICEWAY	EPS	EPM	EPL	EPS8	EPMB	EPLB	F210	F210	F210B	F210B	EL	EL24	ELB	WLT
HY7024											●	●	●	●	●	●	●	●	●	●	●	●	●	●	●	●	●	●
HY7005			●	●	●					●	●	●	●	●	●	●	●	●	●	●	●	●	●	●	●	●	●	●

\*Radio receiver incompatible with Opera system

## ACCESSORIES



**HYA12**  
 LONGER ARTICULATED ARM  
 (SEE THE LAYOUT).  
 PC/PACK 1



**PLA10**  
 VERTICAL 12 V ELECTRIC  
 LOCK (REQUIRED FOR GATES  
 LONGER THAN 3 m).  
 PC/PACK 1



**PLA11**  
 HORIZONTAL 12 V ELECTRIC LOCK  
 (REQUIRED FOR GATES  
 LONGER THAN 3 m).  
 PC/PACK 1



**KIO**  
 KEY-OPERATED SELECTOR  
 SWITCH FOR LOW VOLTAGE  
 CONTACTS, WITH RELEASE  
 MECHANISM FOR METAL  
 CORD.  
 PC/PACK 1

### ACCESSORY

For 24 Vdc version



**KA1**  
 6 m CABLE RELEASE KIT  
 FOR KIO.  
 PC/PACK 1



**TS**  
 SIGNBOARD.  
 PC/PACK 1



**PS324**  
 24 V BATTERY  
 WITH INTEGRATED  
 BATTERY CHARGER.  
 PC/PACK 1



**KIT SOLEMYO**  
 THE SOLAR POWER TO  
 AUTOMATE GATES,  
 GARAGE DOORS OR BARRIER GATES.  
 SEE PAGE 200

# X-FAB

SOLEMYO OPERA BLUEBUS 24V

## For swing gates with leaves up to 2.3 m, underground installation, ultra compact.

Irreversible electromechanical 24 Vdc gear motor, ideal for intensive use.

**Sturdy and discreet:** compact foundation box with a height of only 81 mm.

Steel with cathaphoresis paint finish guarantees optimal resistance to corrosion, and thickness of 2.5 mm guarantees strength. All this in just 52 mm of protrusion from the ground.

**Practical and quick installation** thanks to the exit lever on the gear motor attached directly on the leaf.

**Opening up to 180° as standard.**

**Reliable and sturdy:** the gear motor, in IP67 pressure die cast aluminium, suspended inside the housing to enable drainage of any deposits, ensures optimal water resistance.

Load-bearing foundation box with adjustable mechanical stops on opening and closing: the gear motor can also be installed later as required.

**Practical release** easy to operate from inside and outside, acting directly on the gear motor, easy to operate by means of the special key.

## XFAB2024, compatible with the control unit Moonclever MC424L, and for operation with Solemyo systems:

- simple programming via a single key;
- memorisation of opening and closing limit positions in self-learning mode;
- pause time programming;
- pass door;
- deceleration on opening and closing;
- obstacle detection;
- provision for connection of latest generation sensitive edges;
- operation in event of power failure by means of optional rechargeable batteries (PS124) with compartment in control unit.

## XFAB2124 with magnetic encoder, compatible with control unit Moonclever MC824H, with BlueBUS technology, and compatible for operation with Solemyo and Opera systems:

- simple programming via a single key;
- self-learning of opening and closing limit positions;
- automatic fault diagnostics;
- with output for courtesy light and maintenance indicator;
- speed settings on 5 levels;
- separate and configurable inputs for Step by Step, Open and Close;
- pause time programming;
- pass door;
- deceleration on opening and closing;
- obstacle detection with dual technology;
- provision for connection of latest generation sensitive edges;
- operation in event of power failure by means of optional rechargeable batteries (PS324) with compartment in control unit.

CODE	DESCRIPTION	PACK/PALLET
XFAB2024	IRREVERSIBLE, 24 Vdc	18
XFAB2124	IRREVERSIBLE 24 Vdc VERSION WITH MAGNETIC ENCODER	18
XFABBOX	EXTERNALLY FOUNDATION BOX, WITH CATAPHORESIS PAINT FINISH. COMPLETE WITH LEAF COUPLING LEVER AND MECHANICAL STOPS ON OPENING AND CLOSING	18

## TECHNICAL SPECIFICATIONS

CODE	XFAB2024	XFAB2124
<b>ELECTRICAL DATA</b>		
POWER SUPPLY (Vdc)	24	
ABSORPTION (A)	5	
POWER (W)	120	
<b>PERFORMANCE DATA</b>		
SPEED (rpm)	1.25	
TORQUE (Nm)	250	
WORK CYCLE (CYCLES/HOUR)*	60	
<b>DIMENSIONAL AND GENERAL DATA</b>		
PROTECTION LEVEL (IP)	67	
WORKING TEMP. (°C MIN/MAX)	-20° ÷ +50°	
DIMENSIONS (mm)	235x206x96.5 h	
WEIGHT (kg)	6	

\* The indicated value has to be halved if the opening is up to 180°.

WATERPROOF, WITH IP67 PROTECTION RATING



FOUNDATION BOX WITH CATAPHORESIS PAINT FINISH

## UTILISATION LIMITS

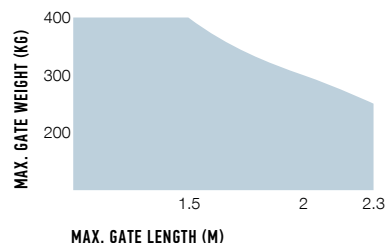

The shape, the height of the gate and the weather conditions can considerably reduce the values shown in the graph to the side.

## DIMENSIONS

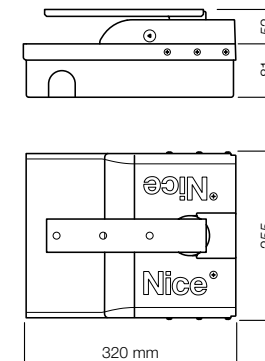



## INSTALLATION DIAGRAM

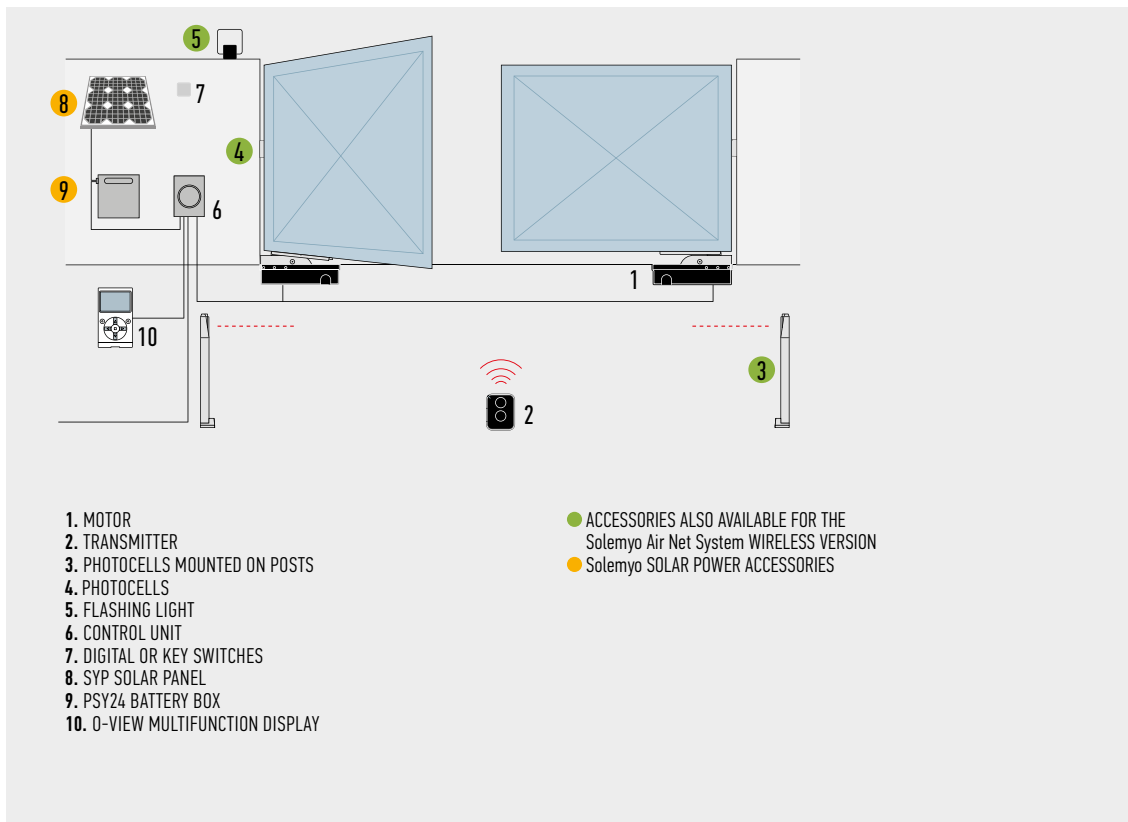

## COMPATIBILITY TABLE WITH CONTROL SYSTEMS AND ACCESSORIES

CODE	CONTROL UNIT / RECEIVER							TRANSMITTER				PHOTOCELLS							FLASHING LIGHT									
	A01 / Built-in*	A02 / Built-in*	A6F / FLOX12R*	A700F / FLOX12R*	A60 / OXI-SMX1*	A500 / FLOX12R*	A924 / FLOX12R*	MC424L / OXI	MC824H / OXI	MC824HR / OXI	ERA INTI	ERA ONE	ERA FLOR	NICEWAY	EPS	EPM	EPL	EPSB	EPMB	EPLB	F210	FT210	F210B	FT210B	EL	EL24	ELB	WLT
XFAB2024							●			●	●	●	●								●	●				●		
XFAB2124								●		●	●	●	●				●	●	●				●			●		●

\*Radio receiver incompatible with Opera system

## ACCESSORIES



**PS124**  
 24 V BATTERY WITH INTEGRATED BATTERY CHARGER FOR MC424L.  
 PC/PACK 1



**PS324**  
 24 V BATTERY WITH INTEGRATED BATTERY CHARGER FOR MC824H.  
 PC/PACK 1



**PLA10**  
 VERTICAL 12 V ELECTRIC LOCK.  
 PC/PACK 1



**PLA11**  
 HORIZONTAL 12 V ELECTRIC LOCK.  
 PC/PACK 1



**TS**  
 SIGNBOARD.  
 PC/PACK 1



**KIT SOLEMYO**  
 THE SOLAR POWER TO AUTOMATE GATES, GARAGE DOORS OR BARRIER GATES. SEE PAGE 200

# X-FABKIT 2024

SOLEMYO 24V

**For swing gates with leaves up to 2.3 m, underground installation, ultra compact.**  
Irreversible electromechanical 24 Vdc gear motor.

**Sturdy and discreet:** compact foundation box with a height of only 81 mm.  
Steel with cataphoresis paint finish guarantees optimal resistance to corrosion, and thickness of 2.5 mm guarantees strength. All this in a protrusion of just 52 mm from the ground.

**Practical and quick installation** thanks to the exit lever on the gear motor attached directly on the leaf.

**Mechanical limit switches** adjustable on opening and closing.  
**Opening up to 180° as standard.**

**Reliable and sturdy:** the gear motor, in IP67 pressure die cast aluminium, suspended inside the housing to enable drainage of any deposits, ensures optimal water resistance.

**Practical release** from inside and outside, acting directly on the gear motor, easy to operate by means of the special key.

**Moonclever control unit MC424L:**

- easy programming by pressing a single button;
- clutch with anti-crush safety feature;
- automatic memorization of limit switches on opening and closing with self-learning function;
- programming of pause time;
- pedestrian pass door;
- deceleration on opening and closing;
- obstacle detection;
- provision for connection of latest generation resistive sensitive edges;
- continues to work even during power failures using optional (PS124) batteries that fit inside the control unit.

**NEW** **The new Era Gate accessories,** with a minimal, modern and discreet design, renovate Nice kits' style and performance.  
Discover the complete range at page 184

CODE	DESCRIPTION	PACK/PALLET
XFAB2024KCE	KIT FOR SWING GATES WITH LEAVES UP TO 2.3 m, 24 Vdc, UNDERGROUND INSTALLATION	12

**N.B.** The content of the package may vary; consult the retailer.

**TECHNICAL SPECIFICATIONS**

CODE	XFAB2024
<b>ELECTRICAL DATA</b>	
POWER SUPPLY (Vdc)	24
ABSORPTION (A)	5
POWER (W)	120
<b>PERFORMANCE DATA</b>	
SPEED (rpm)	1.25
TORQUE (Nm)	250
WORK CYCLE (CYCLES/HOUR)*	60
<b>DIMENSIONAL AND GENERAL DATA</b>	
PROTECTION LEVEL (IP)	67
WORKING TEMP. (°C MIN/MAX)	-20° ÷ +50°
DIMENSIONS (mm)	235x206x96.5 h
WEIGHT (kg)	6

**DIMENSIONS**

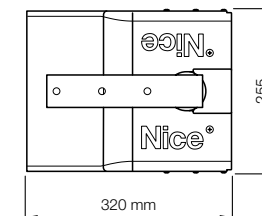
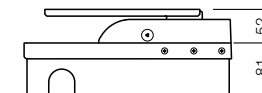

\* The indicated value has to be halved if the opening is up to 180°.

**UTILISATION LIMITS**

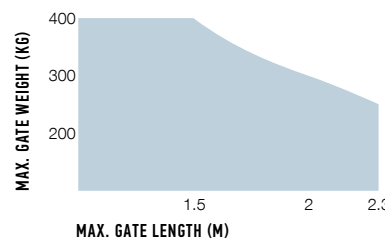

The shape, the height of the gate and the weather conditions can considerably reduce the values shown in the graph to the side.

**THE KIT CONTAINS:**

**XFAB2024**  
2 GEAR MOTORS.  
**XFABBOX**  
2 FOUNDATION BOXES.



**ON2E**  
1 TRANSMITTER 433.92 MHz,  
2 CHANNELS.



**MC424L**  
1 CONTROL UNIT WITH OXI  
PLUG-IN RECEIVER.



**NEW**  
**EPM**  
1 PAIR OF PHOTOCELLS  
FOR OUTDOOR INSTALLATION.



**NEW**  
**EKS**  
1 KEY SELECTOR SWITCH  
FOR OUTDOOR INSTALLATION.



**NEW**  
**EL24**  
1 FLASHING LIGHT  
WITH INTEGRATED AERIAL.



**TS**  
1 SIGNBOARD.



## INSTALLATION DIAGRAM

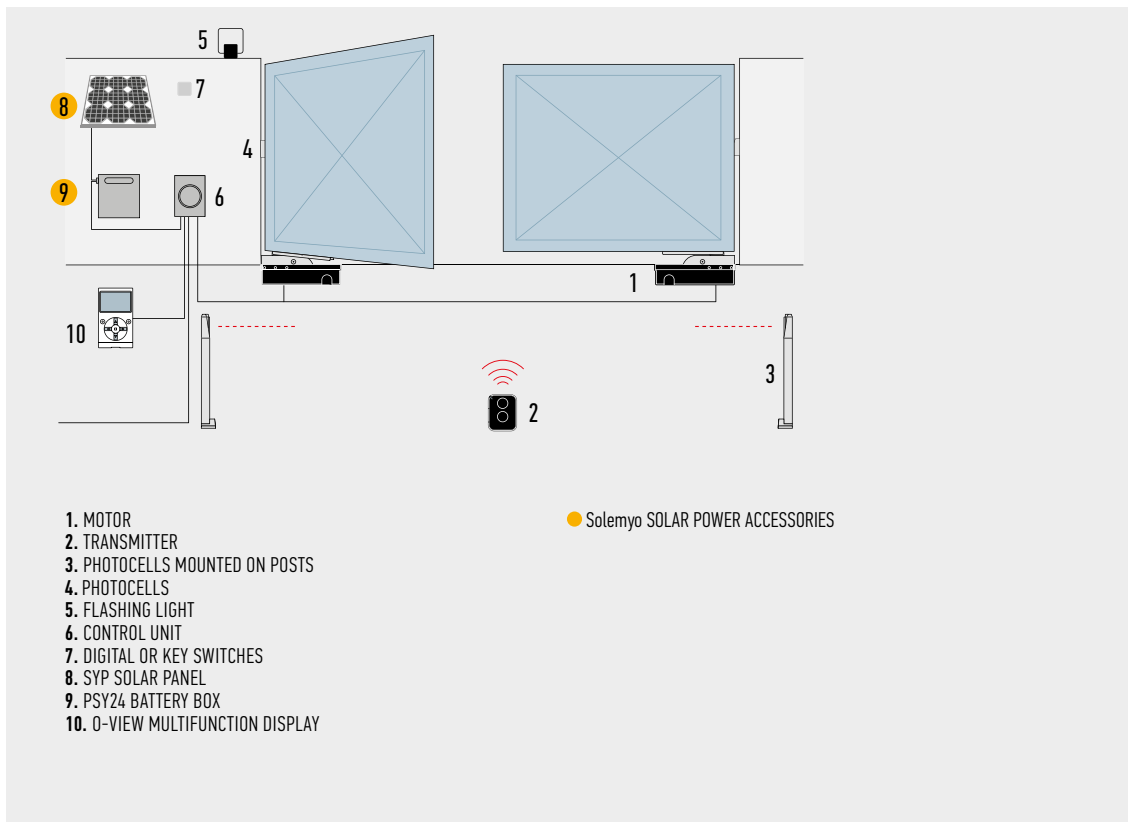

Nice recommends customers order products in pallets in order to facilitate storage and delivery, and ensure packs are uniform. The number of packs per single pallet has been specified for this reason. Approximate draft.

## ACCESSORIES



**PS124**  
 24 V BATTERY  
 WITH INTEGRATED  
 BATTERY CHARGER.  
 PC/PACK 1



**PLA10**  
 VERTICAL 12 V ELECTRIC  
 LOCK.  
 PC/PACK 1



**PLA11**  
 HORIZONTAL 12 V ELECTRIC  
 LOCK.  
 PC/PACK 1



**KIT SOLEMYO**  
 THE SOLAR POWER TO  
 AUTOMATE GATES, GARAGE  
 DOORS OR BARRIER GATES.  
 SEE PAGE 200

FOR SWING GATES

FOR SLIDING GATES

BARRIER GATE  
 OPERATOR SYSTEMS

FOR GARAGE  
 AND INDUSTRIAL DOORS

CONTROL SYSTEMS  
 AND ACCESSORIES

COMPATIBILITY TABLE  
 AND ALPHABETICAL INDEX

# X-FABKIT 2124

SOLEMYO OPERA BLUEBUS 24V

**For swing gates with leaves up to 2.3 m, underground installation, ultra compact.**

Irreversible electromechanical gear motor 24 Vdc with magnetic encoder.

**Sturdy and discreet:** compact foundation box with a height of only 81 mm.

Steel with cathaphoresis paint finish guarantees optimal resistance to corrosion, and thickness of 2.5 mm guarantees strength. All this in a protrusion of just 52 mm from the ground.

**Practical and quick installation**

thanks to the exit lever on the gear motor attached directly on the leaf.

**Mechanical limit switches** adjustable on opening and closing.

**Opening up to 180° as standard.**

**Reliable and sturdy:** the gear motor, in IP67 pressure die cast aluminium, suspended inside the housing to enable drainage of any deposits, ensures optimal water resistance.

**Practical release** from inside and outside, acting directly on the gear motor, easy to operate by means of the special key.

**Control unit Moonclever MC824H, with BlueBUS technology, and compatible for operation with Solemyo and Opera systems:**

- simple programming, by means of a single key;
- self-learning of opening and closing limit positions;
- automatic fault diagnostics;
- programming of pause time;
- pedestrian pass door;
- deceleration on opening and closing;
- obstacle detection with dual technology;
- operation in event of power failure by means of optional rechargeable batteries (PS324);
- provision for connection of latest generation resistive sensitive edges.



**The new Era Gate accessories,** with a minimal, modern and discreet design, renovate Nice kits' style and performance.

Discover the complete range at page 184

CODE	DESCRIPTION	PACK/PALLET
XFAB2124KCE	KIT FOR SWING GATES WITH LEAVES UP TO 2.3 m, 24 Vdc, UNDERGROUND INSTALLATION	12

**N.B.** The content of the package may vary; consult the retailer.

## TECHNICAL SPECIFICATIONS

CODE	XFAB2124
<b>ELECTRICAL DATA</b>	
POWER SUPPLY (Vdc)	24
ABSORPTION (A)	5
POWER (W)	120
<b>PERFORMANCE DATA</b>	
SPEED (rpm)	1.25
TORQUE (Nm)	250
WORK CYCLE (CYCLES/HOUR)*	60
<b>DIMENSIONAL AND GENERAL DATA</b>	
PROTECTION LEVEL (IP)	67
WORKING TEMP. (°C MIN/MAX)	-20° ÷ +50°
DIMENSIONS (mm)	235x206x96.5 h
WEIGHT (kg)	6

\* The indicated value has to be halved if the opening is up to 180°.

## DIMENSIONS

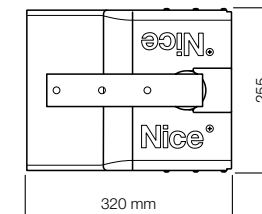
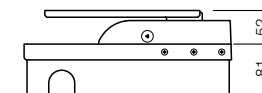

## UTILISATION LIMITS

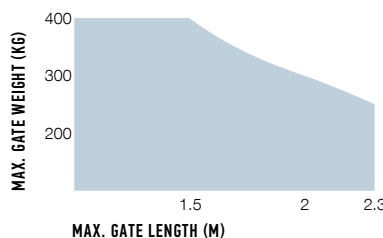

The shape, the height of the gate and the weather conditions can considerably reduce the values shown in the graph to the side.

## THE KIT CONTAINS:

**XFAB2124**  
2 GEAR MOTORS.  
**XFABBOX**  
2 FOUNDATION BOXES.



**ON2E**  
1 TRANSMITTER 433.92 MHz,  
2 CHANNELS.



**MC824H**  
1 CONTROL UNIT WITH OXI  
PLUG-IN RECEIVER.



**EPMB**  
1 COUPLE OF EXTERNAL  
PHOTOCELLS DESIGNED  
FOR CONNECTION BY NICE  
BLUEBUS.



**EKS**  
1 KEY SELECTOR SWITCH  
FOR OUTDOOR INSTALLATION.



**ELB**  
1 FLASHING LIGHT WITH  
INTEGRATED AERIAL.



**TS**  
1 SIGNBOARD.



## INSTALLATION DIAGRAM

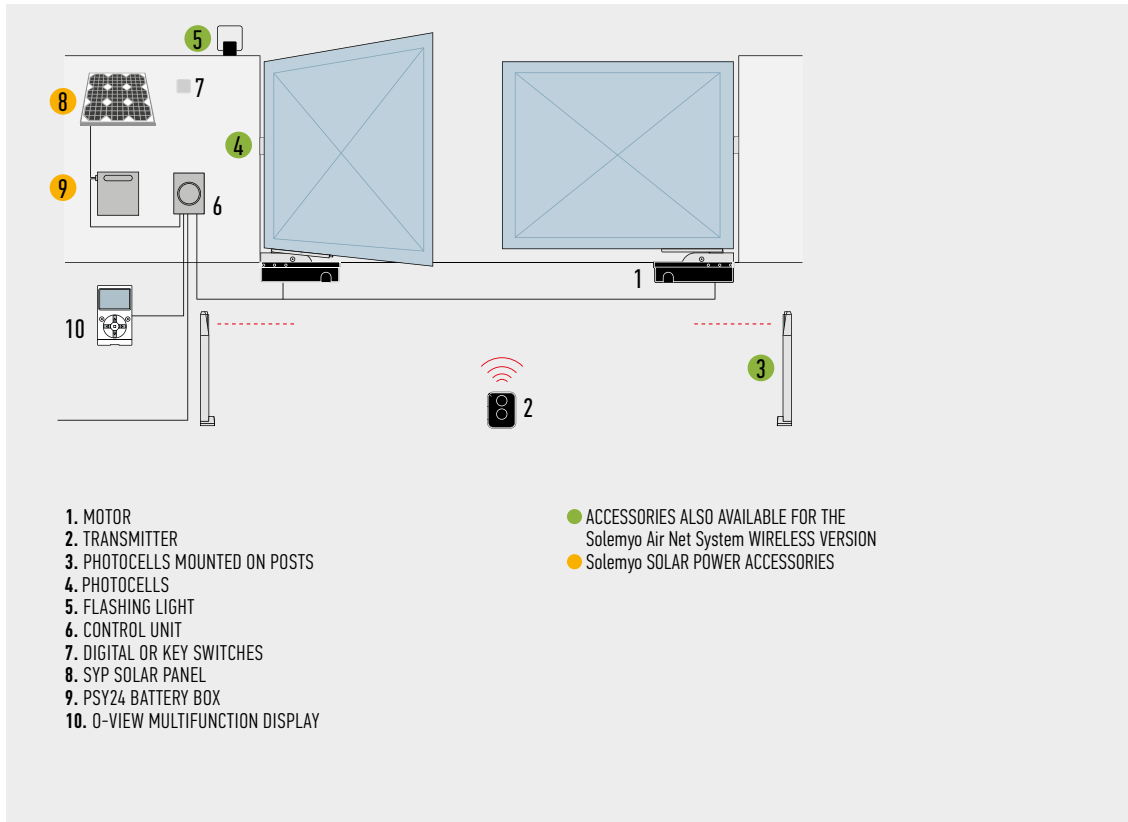

Nice recommends customers order products in pallets in order to facilitate storage and delivery, and ensure packs are uniform. The number of packs per single pallet has been specified for this reason. Approximate draft.

## ACCESSORIES



**PS324**  
 24 V BATTERY WITH INTEGRATED BATTERY CHARGER.  
 PC/PACK 1



**PLA10**  
 VERTICAL 12 V ELECTRIC LOCK.  
 PC/PACK 1



**PLA11**  
 HORIZONTAL 12 V ELECTRIC LOCK.  
 PC/PACK 1



**KIT SOLEMYO**  
 THE SOLAR POWER TO AUTOMATE GATES, GARAGE DOORS OR BARRIER GATES.  
 SEE PAGE 200

FOR SWING GATES

FOR SLIDING GATES

BARRIER GATE OPERATOR SYSTEMS

FOR GARAGE AND INDUSTRIAL DOORS

CONTROL SYSTEMS AND ACCESSORIES

COMPATIBILITY TABLE AND ALPHABETICAL INDEX

# M-FAB

SOLEMYO OPERA BLUEBUS 24V 230V

## For swing gates with leaves up to 3 m, underground installation.

Irreversible electromechanical gear motor, also available in 24 Vdc versions with magnetic encoder.

3 types of electromechanical gear motors irreversible **M-Fab**.

**2 foundation boxes externally chamfered, Fab Box**, with mechanical stop on opening:

- in stainless steel (XFABBOXI), ideal for use in extreme conditions,
- with the **cataphoresis paint finish** (MFABBOX), highly resistant to corrosion.

**Reliable and resistant:** motors made up of solid internal parts in metal. New IP67 waterproof die cast aluminium.

**Total freedom of choice:** release from inside and outside, two key-operated models or freely compatible lever version and easily activated with just one hand.

**Simple to use:** mechanical stop system on closure. Standard opening max. 110°, optional opening 360°.

**Totally compatible** with the previous Metro series.

**Recommended control units:** Mindy A6F, A60, A700F; for MFAB3024 Moonclever MC824H.

**24 Vdc version** with magnetic encoder.

**Perfect for intensive use**, compatible with the control unit Moonclever MC824H:

- simple programming, by means of a single key;
- self-learning of opening and closing limit positions;
- automatic fault diagnostics;
- programming of pause time;
- pedestrian pass door;
- deceleration on opening and closing;
- obstacle detection with dual technology;
- operation in event of power failure by means of optional rechargeable batteries (PS324);
- provision for connection of latest generation resistive sensitive edges.

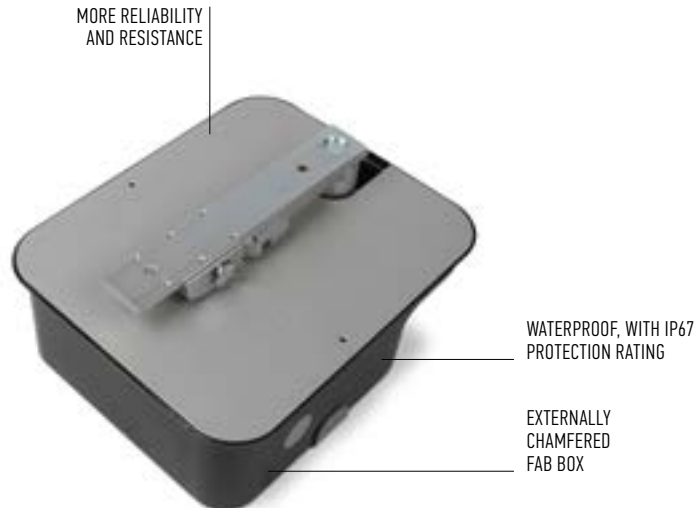

CODE	DESCRIPTION	PACK/PALLET
<b>MFAB3024</b>	IRREVERSIBLE, 24 Vdc, WITH MAGNETIC ENCODER, COMPLETE WITH CONNECTING LEVER AND MECHANICAL STOP FOR THE CLOSING MANOEUVRE	18
<b>MFAB3000</b>	IRREVERSIBLE, 230 Vac, INCREASED SPEED, GREASE LUBRICATION, COMPLETE WITH CONNECTING LEVER AND MECHANICAL STOP FOR THE CLOSING MANOEUVRE	18
<b>MFAB3000L</b>	IRREVERSIBLE, 230 Vac, CRUISING SPEED, GREASE LUBRICATION, COMPLETE WITH CONNECTING LEVER AND MECHANICAL STOP FOR THE CLOSING MANOEUVRE	18

CODE	DESCRIPTION	PACK/PALLET
<b>MFABBOXI</b>	EXTERNALLY CHAMFERED FOUNDATION BOX IN STAINLESS STEEL WITH MECHANICAL STOP ON OPENING	20
<b>MFABBOX</b>	EXTERNALLY CHAMFERED FOUNDATION BOX WITH CATAPHORESIS FINISH WITH MECHANICAL STOP ON OPENING	20

**NOTE:** key release mechanism, freely compatible with selection of models MEA2 and MEA3 motor.

## TECHNICAL SPECIFICATIONS

CODE	MFAB3024	MFAB3000	MFAB3000L
<b>ELECTRICAL DATA</b>			
POWER SUPPLY (Vac 50 Hz)*	-	230	
POWER SUPPLY (Vdc)	24	-	
ABSORPTION (A)	5	1.2	1.3
POWER (W)	120	250	300
<b>PERFORMANCE DATA</b>			
SPEED (rpm)	1.4	1.14	0.8
TORQUE (Nm)	250	300	250
WORK CYCLE (CYCLES/HOUR)**	76	30	20
<b>DIMENSIONAL AND GENERAL DATA</b>			
PROTECTION LEVEL (IP)	67		
WORKING TEMP. (°C MIN/MAX)	-20 ÷ +50		
DIMENSIONS (mm)	390x322x194.5 h		
WEIGHT (kg)	11		

\*60 Hz version available on request. \*\*The indicated value has to be halved if the opening is up to 180° - by using the MEA1 accessory.

## UTILISATION LIMITS

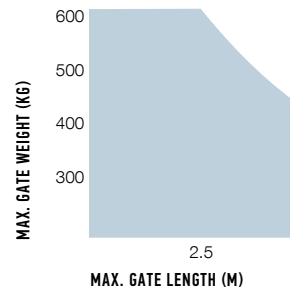

The shape, the height of the gate and the weather conditions can considerably reduce the values shown in the graph to the side. Use in windy areas 230 Vac models.

## DIMENSIONS

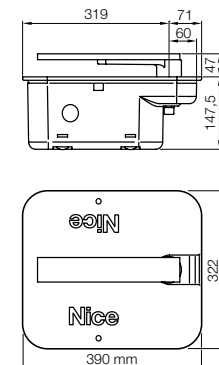

## INSTALLATION DIAGRAM

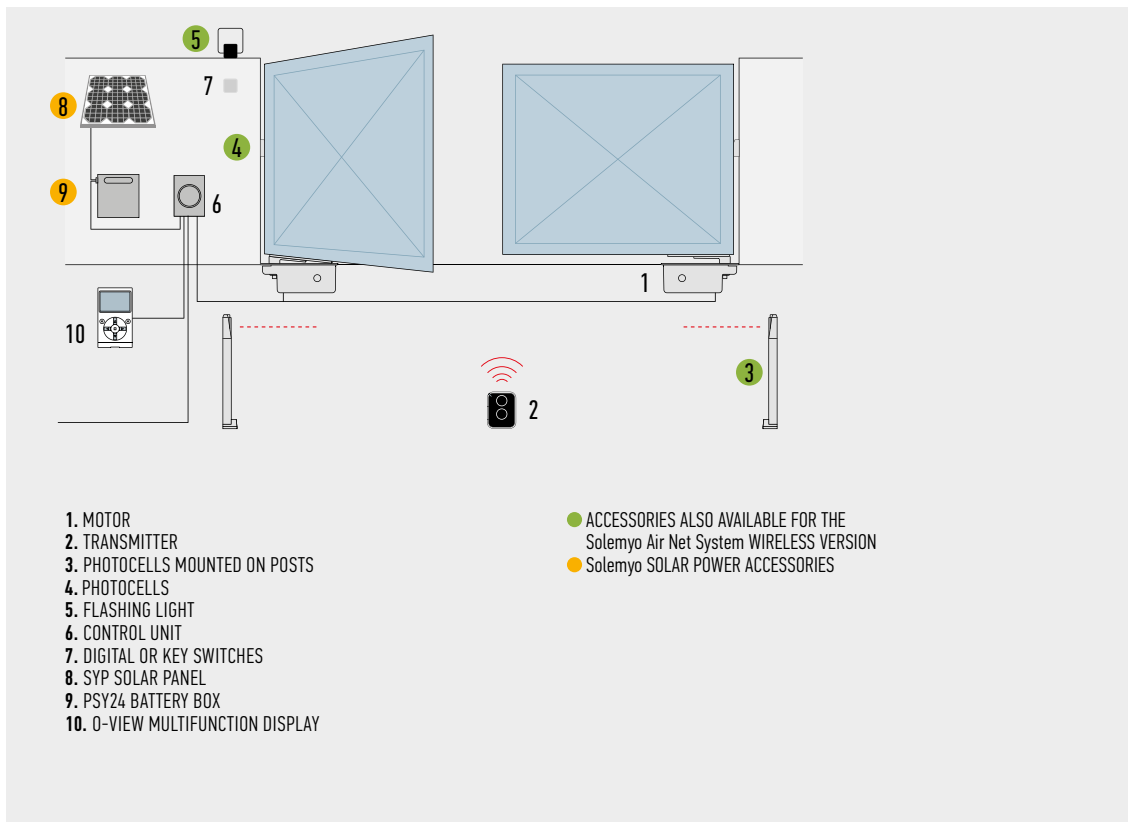

## COMPATIBILITY TABLE WITH CONTROL SYSTEMS AND ACCESSORIES

CODE	CONTROL UNIT / RECEIVER										TRANSMITTER				PHOTOCELLS							FLASHING LIGHT						
	A01 / Built-in*	A02 / Built-in*	A6F / FLOX12R*	A700F / FLOX12R*	A60 / OXI-SMX1*	A500 / FLOX12R*	A924 / FLOX12R*	MC424L / OXI	MC824H / OXI	MC824HR / OXI	ERA INTI	ERA ONE	ERA FLOR	NICEWAY	EPS	EPM	EPL	EPSB	EPMB	EPLB	F210	FT210	F210B	FT210B	EL	EL24	ELB	WLT
MFAB3024										●	●	●	●	●	●	●	●	●	●	●	●	●	●	●	●	●	●	●
MFAB3000			●	●	●					●	●	●	●	●	●	●	●	●	●	●	●	●	●	●	●	●	●	●
MFAB3000L			●	●	●					●	●	●	●	●	●	●	●	●	●	●	●	●	●	●	●	●	●	●

\*Radio receiver incompatible with Opera system

## ACCESSORIES



**ME2**  
KEY UNLOCK SYSTEM.  
PC/PACK 1



**ME3**  
LEVER-TYPE KEY UNLOCK SYSTEM TO USE WHEN SYSTEM IS INSTALLED ON SURFACES SUCH AS SAND OR EARTH.  
PC/PACK 1



**ME5**  
LEVER-TYPE UNLOCK KEY FOR MEA3.  
PC/PACK 4



**ME6**  
LIMIT SWITCH BRACKET, FOR INSTALLATIONS WHERE BOX EMBEDDING IN CONCRETE IS NOT POSSIBLE.  
PC/PACK 1



**ME1**  
ACCESSORY FOR OPENING UP TO 360° FOR GATES MAX. 2.5 m IN LENGTH.  
PC/PACK 1



**PLA10**  
VERTICAL 12 V ELECTRIC LOCK.  
PC/PACK 1



**PLA11**  
HORIZONTAL 12 V ELECTRIC LOCK.  
PC/PACK 1



**TS**  
SIGNBOARD.  
PC/PACK 1

## ACCESSORY

For 24 Vdc version



**PS324**  
24 V BATTERY WITH INTEGRATED BATTERY CHARGER.  
PC/PACK 1



**KIT SOLEMYO**  
THE SOLAR POWER TO AUTOMATE GATES, GARAGE DOORS OR BARRIER GATES. SEE PAGE 200

Nice recommends customers order products in pallets in order to facilitate storage and delivery, and ensure packs are uniform. The number of packs per single pallet has been specified for this reason. Approximate draft.

FOR SWING GATES

FOR SLIDING GATES

BARRIER GATE OPERATOR SYSTEMS

FOR GARAGE AND INDUSTRIAL DOORS

CONTROL SYSTEMS AND ACCESSORIES

COMPATIBILITY TABLE AND ALPHABETICAL INDEX

# L-FAB

SOLEMYO OPERA BLUEBUS 24V 230V

## For swing gates with leaves up to 4 m, underground installation.

Irreversible electromechanical gear motor, also available in 24 Vdc versions with magnetic encoder and mechanical stop.

Foundation boxes with mechanical stop on opening:

- in stainless steel (LFABBOX4I), ideal for use in extreme conditions,
- with cataphoresis paint finish (LFABBOX4), highly resistant to corrosion.

**Maximum freedom of choice:** release from inside or outside, two key or lever operated models, freely combinable and easy to operate with just one hand.

**Simple installation:** built-in mechanical stop system on closure.

Standard opening to 110°, or optional 360°.

**Ideal for intensive use, LFAB4024 model is compatible with the control unit Moonclever MC824H, with BlueBUS technology, Solemyo and Opera systems:**

- simple programming via a single key;
- self-learning of travel limits on opening and closing;
- self-diagnostics of faults;
- programming of pause time;
- pass door;
- deceleration on opening and closing;
- dual technology obstacle detection;
- operation in the event of a power failure with optional rechargeable batteries (PS324);
- provision for connection of latest generation sensitive edges.

LFAB4000 model is compatible with the control units A6F and A60.

RELIABILITY AND RESISTANCE



WATERPROOF, WITH IP67 PROTECTION RATING

### ACCESSORY FOR L-FAB

**BMA2**  
ADAPTORS FOR A DUAL MOTOR AUTOMATION, COMPATIBLE WITH THE MAJORITY OF FOUNDATION BOXES ON THE MARKET.

PC/PACK. 4



CODE	DESCRIPTION	PACK/PALLET
LFAB4000	IRREVERSIBLE 230 Vac WITH BUILT-IN MECHANICAL STOP ON CLOSING	18
LFAB4024	IRREVERSIBLE 24 Vdc, WITH MAGNETIC ENCODER, WITH MECHANICAL STOP ON CLOSING	18
LFABBOX4	FOUNDATION BOX WITH CATAPHORESIS PAINT FINISH FOR LFAB4000 AND LFAB4024 WITH BUILT-IN MECHANICAL STOP ON OPENING. COMPLETE WITH LEAF COUPLING LEVER	18
LFABBOX4I	STAINLESS STEEL FOUNDATION BOX FOR LFAB4000 AND LFAB4024 WITH BUILT-IN MECHANICAL STOP ON OPENING. COMPLETE WITH LEAF COUPLING LEVER	18

Note: key release mechanism, freely compatible with selection of models MEA2 and MEA3 motor.

### TECHNICAL SPECIFICATIONS

CODE	LFAB4024	LFAB4000
<b>ELECTRICAL DATA</b>		
POWER SUPPLY (Vac 50/60 Hz)	-	230
POWER SUPPLY (Vdc)	24	-
ABSORPTION (A)	5	1.5
POWER (W)	120	340
<b>PERFORMANCE DATA</b>		
SPEED (rpm)	1	0.8
TORQUE (Nm)	300	500
WORK CYCLE (CYCLES/HOUR)**	60	20

### DIMENSIONAL AND GENERAL DATA

PROTECTION LEVEL (IP)	67	
WORKING TEMP. (°C MIN/MAX)	-20 ÷ +50	
DIMENSIONS (mm)*	400x325x152 h	
WEIGHT (kg)	12.5	14.3

\*With foundation box. \*\*The indicated value has to be halved if the opening is up to 180° - by using the BMA1 accessory.

FOUNDATION BOX	LFABBOX4
WEIGHT (kg)	14.4

### UTILISATION LIMITS

#### LFAB4000 - LFAB4024

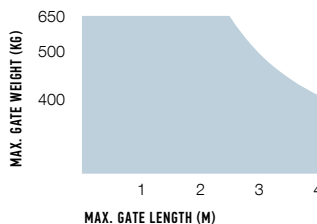

The shape, the height of the gate and the weather conditions can considerably reduce the values shown in the graph to the side. Use in windy areas 230 Vac models.

### DIMENSIONS

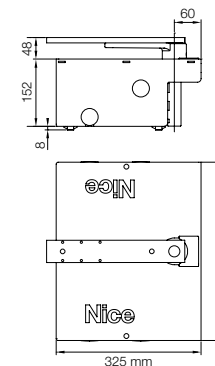



## INSTALLATION DIAGRAM

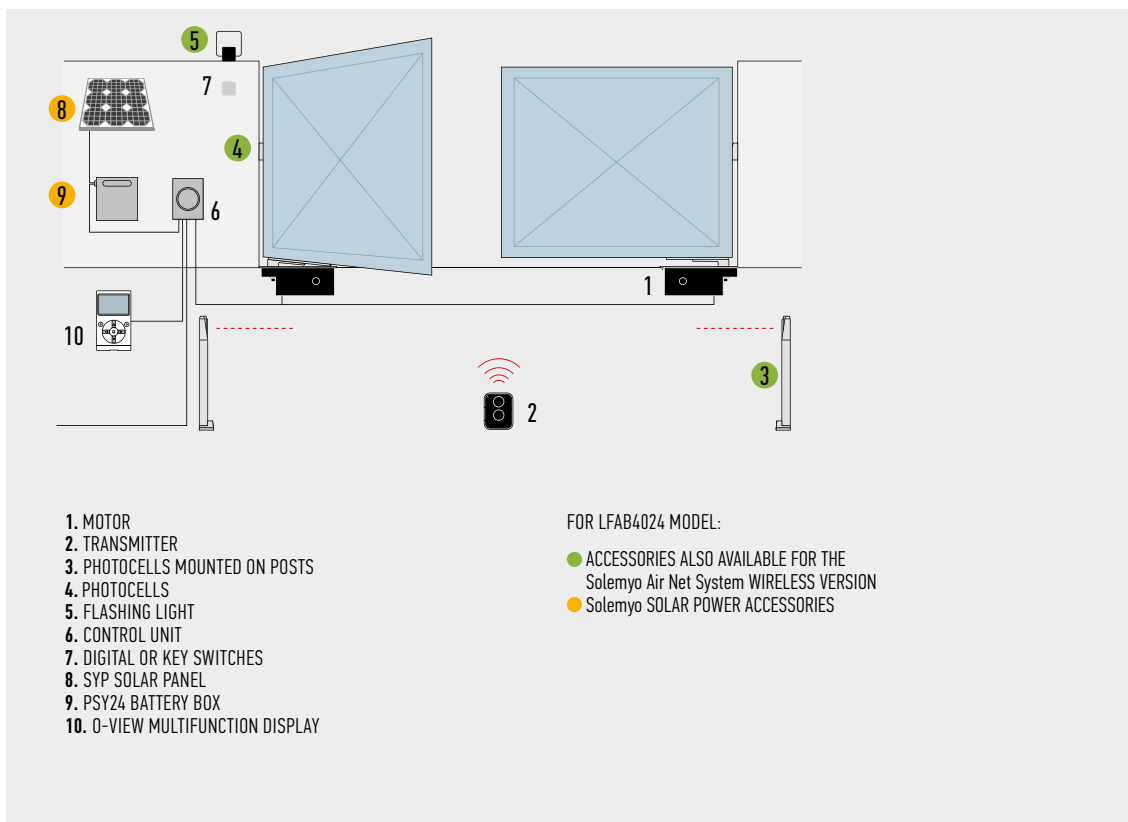

1. MOTOR
2. TRANSMITTER
3. PHOTOCELLS MOUNTED ON POSTS
4. PHOTOCELLS
5. FLASHING LIGHT
6. CONTROL UNIT
7. DIGITAL OR KEY SWITCHES
8. SYP SOLAR PANEL
9. PSY24 BATTERY BOX
10. 0-VIEW MULTIFUNCTION DISPLAY

- FOR LFAB4024 MODEL:**
- ACCESSORIES ALSO AVAILABLE FOR THE Solemyo Air Net System WIRELESS VERSION
  - Solemyo SOLAR POWER ACCESSORIES

## COMPATIBILITY TABLE WITH CONTROL SYSTEMS AND ACCESSORIES

CODE	CONTROL UNIT / RECEIVER							TRANSMITTER				PHOTOCELLS							FLASHING LIGHT									
	A01 / Built-in*	A02 / Built-in*	A6F / FLOX12R*	A700F / FLOX12R*	A60 / OX1-SMX1*	A500 / FLOX12R*	A924 / FLOX12R*	MC424L / OXI	MC824H / OXI	MC824HR / OXI	ERA INTI	ERA ONE	ERA FLOR	NICEWAY	EPS	EPM	EPL	EPSB	EPMB	EPLB	F210	FT210	F210B	FT210B	EL	EL24	ELB	WLT
LFAB4000			●	●	●					●	●	●	●				●	●	●		●			●				
LFAB4024								●		●	●	●	●				●	●	●		●					●	●	

\*Radio receiver incompatible with Opera system

## ACCESSORIES



**MEA2**  
KEY UNLOCK SYSTEM.  
PC/PACK 1



**MEA3**  
LEVER-TYPE KEY UNLOCK SYSTEM TO USE WHEN SYSTEM IS INSTALLED ON SURFACES SUCH AS SAND OR EARTH.  
PC/PACK 1



**MEA5**  
LEVER-TYPE UNLOCK KEY FOR MEA3.  
PC/PACK 4



**BMA1**  
ACCESSORY FOR OPENING UP TO 360° FOR GATES MAX. 3.5 m IN LENGTH.  
PC/PACK 1



**PLA10**  
VERTICAL 12 V ELECTRIC LOCK (REQUIRED FOR GATES LONGER THAN 3 m).  
PC/PACK 1



**PLA11**  
HORIZONTAL 12 V ELECTRIC LOCK (REQUIRED FOR GATES LONGER THAN 3 m).  
PC/PACK 1



**TS**  
SIGNBOARD.  
PC/PACK 1

## ACCESSORY

For 24 Vdc version



**PS324**  
24 V BATTERY WITH INTEGRATED BATTERY CHARGER.  
PC/PACK 1



**KIT SOLEMYO**  
THE SOLAR POWER TO AUTOMATE GATES, GARAGE DOORS OR BARRIER GATES. SEE PAGE 200

FOR SWING GATES

FOR SLIDING GATES

BARRIER GATE OPERATOR SYSTEMS

FOR GARAGE AND INDUSTRIAL DOORS

CONTROL SYSTEMS AND ACCESSORIES

COMPATIBILITY TABLE AND ALPHABETICAL INDEX

# BIG-FAB

SOLEMYO OPERA BLUEBUS 24V

## For swing gates with leaves up to 5 m, underground installation.

Irreversible electromechanical gear motor, 24 Vdc with magnetic encoder and mechanical stop.

**Chamfered foundation boxes** with mechanical stop on opening:

- in stainless steel (BFABBOXI), ideal for use in extreme conditions,
- with cataphoresis paint finish (BFABBOX), highly resistant to corrosion.

**Maximum freedom of choice:** release from inside or outside, two key or lever operated models, freely combinable and easy to operate with just one hand.

**Simple to use:** mechanical stop system on closure. Standard opening to 110°, or optional 360°.

**Ideal for intensive use, compatible with the control unit Moonclever MC824H:**

- simple programming via a single key;
- self-learning of travel limits on opening and closing;
- self-diagnostics of faults;
- programming of pause time;
- pass door;
- deceleration on opening and closing;
- dual technology obstacle detection;
- operation in the event of a power failure with optional rechargeable batteries (PS324);
- provision for connection of latest generation sensitive edges.



### ACCESSORY FOR L-FAB

**BMA2**  
ADAPTORS FOR A DUAL MOTOR AUTOMATION, COMPATIBLE WITH THE MAJORITY OF FOUNDATION BOXES ON THE MARKET.

PC/PACK. 4



CODE	DESCRIPTION	PACK/PALLET
<b>BFAB5024</b>	IRREVERSIBLE, 24 Vdc, WITH MAGNETIC ENCODER, WITH MECHANICAL STOP ON CLOSING	18
<b>BFABBOX</b>	FOUNDATION BOX, WITH CATAPHORESIS PAINT FINISH, WITH BUILT-IN MECHANICAL STOP ON OPENING	18
<b>BFABBOXI</b>	STAINLESS STEEL FOUNDATION BOX, WITH BUILT-IN MECHANICAL STOP ON OPENING	18

**NOTE:** key release mechanism, freely compatible with selection of models MEA2 and MEA3 motor.

### TECHNICAL SPECIFICATIONS

CODE	BFAB5024
<b>ELECTRICAL DATA</b>	
POWER SUPPLY (Vdc)	24
ABSORPTION (A)	7
POWER (W)	170
<b>PERFORMANCE DATA</b>	
SPEED (rpm)	0.8
TORQUE (Nm)	400
WORK CYCLE (CYCLES/HOUR)**	45
<b>DIMENSIONAL AND GENERAL DATA</b>	
PROTECTION LEVEL (IP)	67
WORKING TEMP. (°C MIN/MAX)	-20 ÷ +50
DIMENSIONS (mm)*	400x325x152 h
WEIGHT (kg)	13.3

\*With foundation box. \*\*The indicated value has to be halved if the opening is up to 180° - by using the BMA1 accessory.

FOUNDATION BOX	BFABBOX
WEIGHT (kg)	20.3

### UTILISATION LIMITS

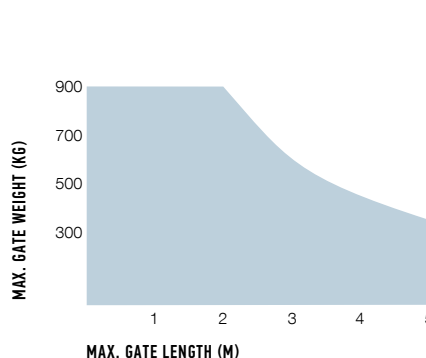

The shape, the height of the gate and the weather conditions can considerably reduce the values shown in the graph to the side. Use in windy areas 230 Vac models.

### DIMENSIONS

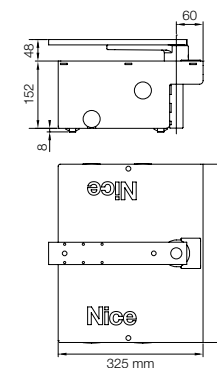

## INSTALLATION DIAGRAM

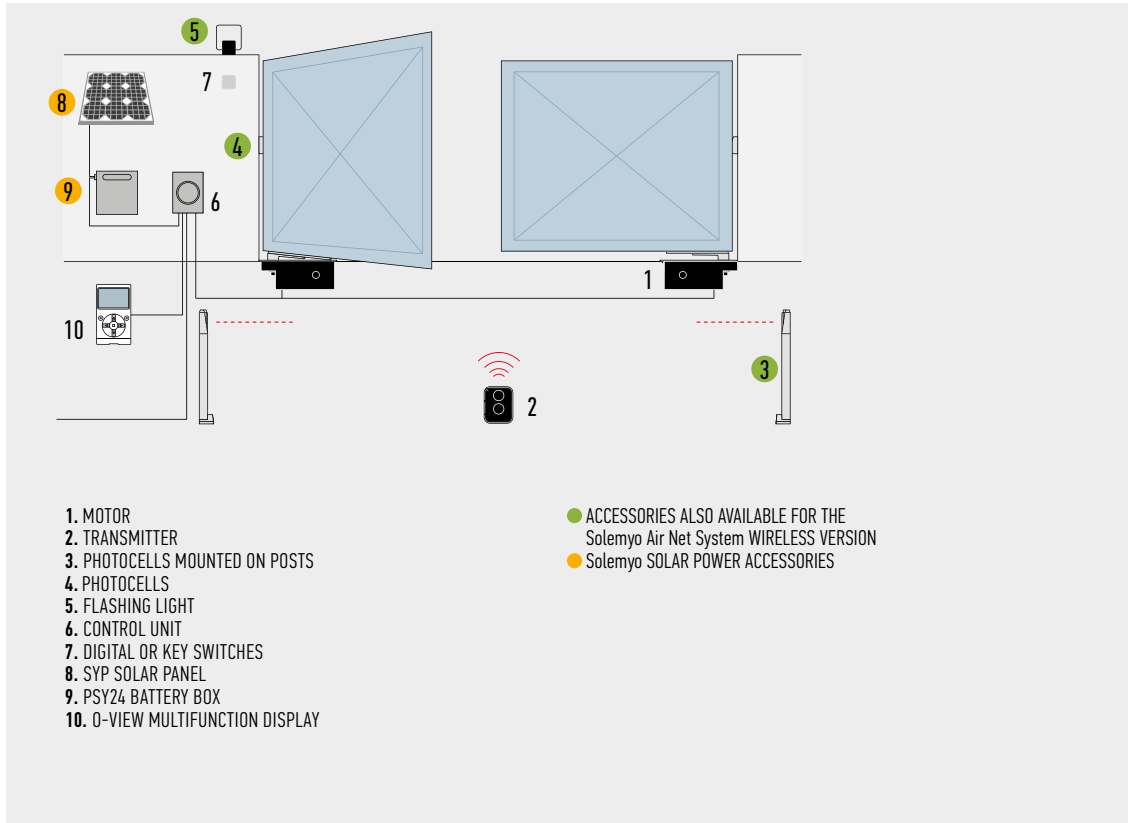

## COMPATIBILITY TABLE WITH CONTROL SYSTEMS AND ACCESSORIES

CODE	CONTROL UNIT / RECEIVER								TRANSMITTER				PHOTOCELLS							FLASHING LIGHT						
	A01 / Built-in*	A02 / Built-in*	A6F / FLOX12R*	A700F / FLOX12R*	A60 / OXI-SMX1*	A500 / FLOX12R*	A924 / FLOX12R*	MC424L / OXI	MC824H / OXI	ERA INTI	ERA ONE	ERA FLOR	NICEWAY	EPS	EPM	EPL	EPSB	EPMB	EPLB	F210	FT210	F210B	FT210B	EL	EL24	ELB
<b>BFAB5024</b>					●				●	●	●	●				●	●	●			●			●	●	●

\*Radio receiver incompatible with Opera system

## ACCESSORIES



**MEA2**  
KEY UNLOCK SYSTEM.  
PC/PACK 1



**MEA3**  
LEVER-TYPE KEY UNLOCK SYSTEM TO USE WHEN SYSTEM IS INSTALLED ON SURFACES SUCH AS SAND OR EARTH.  
PC/PACK 1



**MEA5**  
LEVER-TYPE UNLOCK KEY FOR MEA3.  
PC/PACK 4



**BMA1**  
ACCESSORY FOR OPENING UP TO 360° FOR GATES MAX. 3.5 m IN LENGTH.  
PC/PACK 1



**PLA10**  
VERTICAL 12 V ELECTRIC LOCK (REQUIRED FOR GATES LONGER THAN 3 m).  
PC/PACK 1



**PLA11**  
HORIZONTAL 12 V ELECTRIC LOCK (REQUIRED FOR GATES LONGER THAN 3 m).  
PC/PACK 1



**TS**  
SIGNBOARD.  
PC/PACK 1

## ACCESSORY

For 24 Vdc version



**PS324**  
24 V BATTERY WITH INTEGRATED BATTERY CHARGER.  
PC/PACK 1



**KIT SOLEMYO**  
THE SOLAR POWER TO AUTOMATE GATES, GARAGE DOORS OR BARRIER GATES. SEE PAGE 200



# SYSTEMS FOR SLIDING GATES



FOR RESIDENTIAL USE, INSTALLED	88	NAKED SLIDING 400
ALSO INSIDE A COMPACT POST	88	SLIGHT
	90	SLIGHTKIT

---

FOR RESIDENTIAL AND INDUSTRIAL USE	92	ROBUS 400/600/1000
	94	ROBUSKIT 400
	96	ROBUSKIT 600
	98	ROADKIT
	100	RUN 1500
	102	RUN 1800/2500
	104	TUB

---

RACKS	105
-------	-----

# SELECTION GUIDE

## FOR RESIDENTIAL USE, INSTALLED ALSO INSIDE A COMPACT POST

Irreversible, 24 Vdc, with built-in control unit and absolute encoder.  
With BlueBUS technology, compatible for operation with Solemyo and Opera.  
**NAKED SLIDING 400**  
pages 88/89

for gates up to 400 kg

**NKSL400**

Irreversible, 24 Vdc, with built-in control unit and absolute encoder.  
With BlueBUS technology, compatible for operation with Solemyo and Opera.  
**SLIGHT**  
**SLIGHTKIT**  
pages 88/91

for gates up to 400 kg

**SLH400**

**SLH400KCE**

**KIT**



## FOR RESIDENTIAL USE, ALSO AVAILABLE IN KIT

Irreversible, 24 Vdc, with built-in control unit.  
With BlueBUS technology, compatible for operation with Solemyo and Opera.

**ROBUS HS** NEW  
pages 33/33

**ROBUS**  
**ROBUSKIT**  
pages 92/97

for gates up to 250 kg  
with electromechanical limit switch

Hi-Speed

**RB350HS**

for gates up to 400 kg  
with electromechanical limit switch

**KIT**

**RB400**

**RB400KCE**

for gates up to 500 kg  
with electromechanical limit switch

Hi-Speed

**RB500HS**

for gates  
up to 600 kg

electromechanical limit switch

**KIT**

**RB600**

**RB600KCE**

inductive limit switch

**RB600P**

for gates  
up to 1000 kg

electromechanical limit switch

inductive limit switch

**RB1000**

**RB1000P**

Irreversible, 24 Vdc,  
with built-in control unit.  
For gates up to 400 kg  
with leaf length up to 6 m  
**ROADKIT**  
pages 98/99

**RDKCE**



**FOR RESIDENTIAL AND INDUSTRIAL USE**

Irreversible,  
with built-in control unit,  
with BlueBUS technology.

**RUN HS**  
pages 34/35 

**RUN**  
pages 100/103

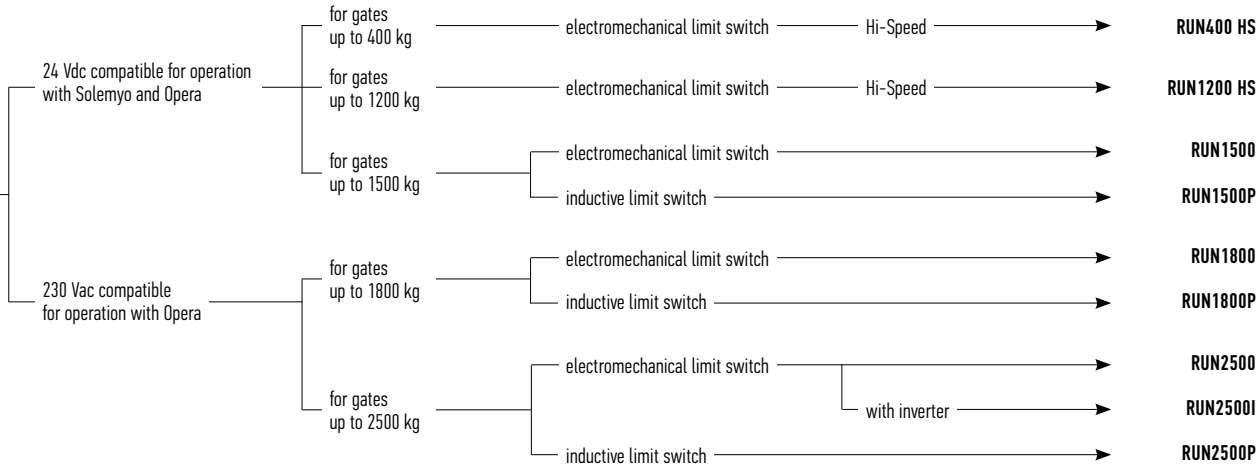

**FOR INDUSTRIAL USE**

Irreversible, 400 Vac,  
with built-in control unit.

**TUB**  
pages 104



FOR SWING GATES

FOR SLIDING GATES

BARRIER GATE  
OPERATOR SYSTEMS

FOR GARAGE  
AND INDUSTRIAL DOORS

CONTROL SYSTEMS  
AND ACCESSORIES

COMPATIBILITY TABLE  
AND ALPHABETICAL INDEX

# NAKED SLIDING 400

SOLEMYO OPERA BLUEBUS 24V

## Nice concealed motor for sliding gates up to 400 Kg with leaf length up to 6 m.

Motor with built-in control unit and absolute encoder which can be installed inside a compact post with suitable holes.

Its extremely small size allows the motor to be installed even in very slender posts, with interior size down to 140x140 mm.

**User-friendly:** thanks to the BlueBUS system, allowing the control unit to be connected to up to 7 pairs of photocells and control, security and signalling devices with just two wires.

**State-of-the-art:** it features a temperature sensor that adapts the motor force to weather conditions, also modulating the overload protection.

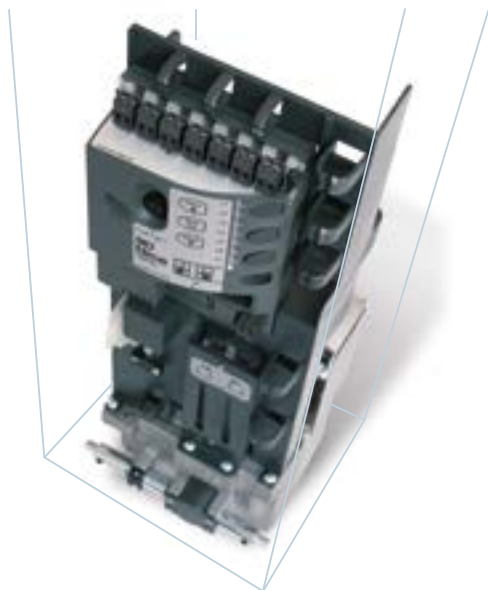

**Master/slave selection:** for automatic synchronisation even of 2 motors, allowing automation of sliding gates with two opposing leaves.

**Intelligent:** thanks to obstacle detection and automatic working time programming. Self-diagnostics with flashing light signalling.

**Safe:** adjustable acceleration and deceleration at the start and end of every opening and closing operation.

**User-friendly, precise limit switch adjustment:** integral absolute limit switch, quick learning with just one opening or closing operation with motor released.

**Practical:** control unit and optional PS124 buffer batteries can be connected by means of practical guided - connector.

**Flexible:** unlocking can be provided on both sides of the post and/or on the outside (with the K10 and KA1 accessories). Also easy to install on existing posts.



# SLIGHT

SOLEMYO OPERA BLUEBUS 24V

## Nice motor for sliding gates up to 400 kg with leaf length up to 6 m.

Motor with built-in control unit and absolute encoder.

**Innovative ultra-compact design:** the vertical configuration of the motor makes it easy to install even in narrow openings.

**User-friendly:** thanks to the BlueBUS system, it allows the control unit to be connected to up to 7 pairs of photocells and control, security and signalling devices with just two wires.

**Built-in LED light:** programmable as either a flashing or courtesy light, it warns of gate movement during opening and closing.

**Master/slave selection:** for automatic synchronisation even of 2 motors, allowing automation of sliding gates with two opposing leaves.

**Intelligent:** thanks to obstacle detection and automatic working time programming. Self-diagnostics with flashing light signalling.

**Safe:** adjustable acceleration and deceleration at the start and end of every opening and closing operation.

### Built-in absolute limit stop:

- simple and precise regulation thanks to the rapid learning in a single movement with the motor released;
- no bracket or accessory to be installed on the ratchet;
- particularly suitable in snow areas.

**Practical:** control unit and optional PS124 buffer batteries can be connected by means of practical guided - connector.



COURTESY OR FLASHING LED LIGHT





CODE	DESCRIPTION	PACK/PALLET
<b>NKSL400</b>	IRREVERSIBLE, 24 Vdc, WITH BUILT-IN CONTROL UNIT AND ABSOLUTE ENCODER ALLOWING INTEGRATION IN POST	16
<b>SLH400</b>	IRREVERSIBLE, 24 Vdc, WITH BUILT-IN CONTROL UNIT AND ABSOLUTE ENCODER WITH BUILT-IN LED LIGHT	16

### TECHNICAL SPECIFICATIONS

CODE	NKSL400	SLH400
<b>ELECTRICAL DATA</b>		
POWER SUPPLY (Vac 50/60 Hz)	230	230
ABSORPTION (A)	1.1	1.1
POWER (W)	250	250
<b>PERFORMANCE DATA</b>		
SPEED (m/s)	0.34	0.34
FORCE (N)	400	400
WORK CYCLE (CYCLES/HOUR)	35	35
<b>DIMENSIONAL AND GENERAL DATA</b>		
PROTECTION LEVEL (IP)	10*	44
WORKING TEMP. (°C MIN/MAX)	-20 ÷ +50	-20 ÷ +50
DIMENSIONS (mm)	131x172x405 h	191x198x408 h
WEIGHT (kg)	6.5	8

\* The protection degree of the automation is determined by the composition motor and column.

### DIMENSIONS

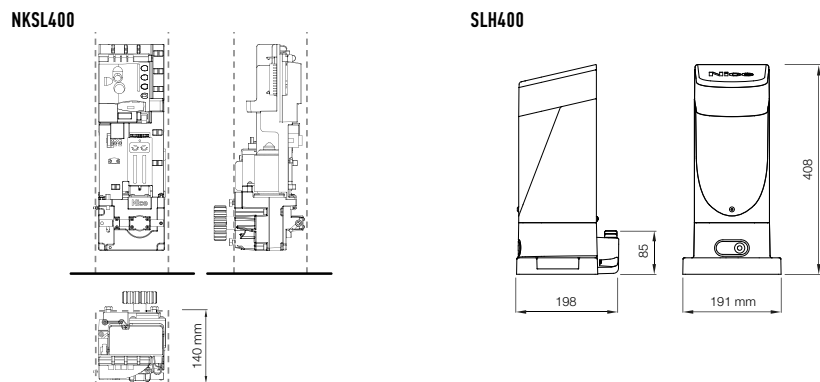

### COMPATIBILITY TABLE WITH CONTROL SYSTEMS AND ACCESSORIES

CODE	RECEIVER		TRANSMITTER				PHOTOCELLS						FLASHING LIGHT								
	Built-in*	FLOX1ZR*	OXI	ERA INTI	ERA ONE	ERA FLOR	NICEWAY	EPS	EPM	EPL	EPSB	EPMB	EPLB	FZ10	FT210	FZ10B	FT210B	EL	EL24	ELB	WLT
<b>SLH400</b>			●	●	●	●	●				●	●	●			●	●			●	●
<b>NKSL400</b>			●	●	●	●	●				●	●	●			●	●			●	●

\*Radio receiver incompatible with Opera system

### ACCESSORIES



**NKA3**  
SPARE CONTROL UNIT.  
PC/PACK 1



**PS124**  
24 V BATTERY WITH INTEGRATED BATTERY CHARGER.  
PC/PACK 1



**ROA6**  
M4 25x20x1000 mm SLOTTED NYLON RACK WITH METAL INSERT FOR GATES WEIGHING UP TO 500 kg.  
PC/PACK 10



**ROA7**  
M4 RACK, ZINC COATED, 22x22x1000 mm.  
PC/PACK 10



**ROA8**  
M4 RACK, 30x8x1000 mm, ZINC COATED WITH SPACERS AND SCREWS.  
PC/PACK 10



**K10**  
KEY-OPERATED SELECTOR SWITCH FOR LOW VOLTAGE CONTACTS, WITH RELEASE MECHANISM FOR METAL CORD.  
PC/PACK 1



**KA1**  
6 m CABLE RELEASE KIT FOR K10.  
PC/PACK 1



**TS**  
SIGNBOARD.  
PC/PACK 1



**KIT SOLEMYO**  
THE SOLAR POWER TO AUTOMATE GATES, GARAGE DOORS OR BARRIER GATES. SEE PAGE 200

### INSTALLATION DIAGRAM

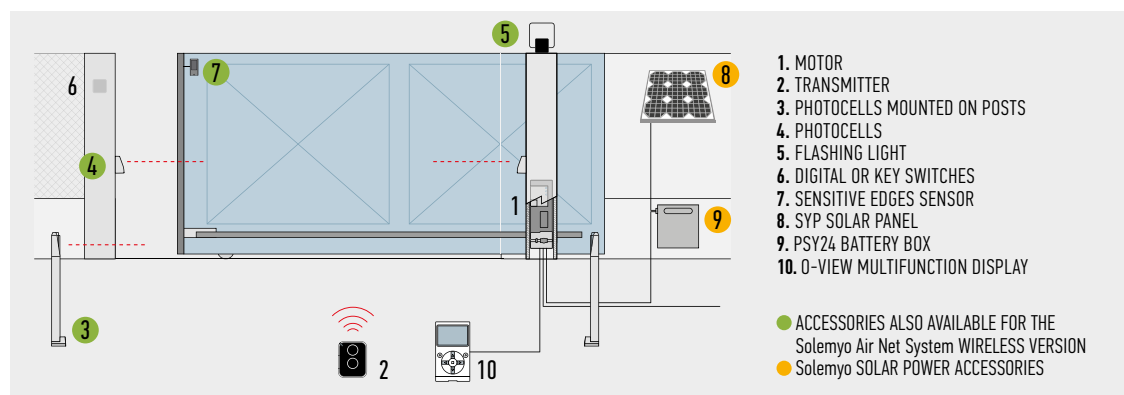

# SLIGHT KIT

NEW SOLEMYO OPERA BLUEBUS 24V

## Nice motor for sliding gates up to 400 kg with leaf length up to 6 m.

Motor with built-in control unit and absolute encoder.

**Innovative ultra-compact design:** the vertical configuration of the motor makes it easy to install even in narrow openings.

**User-friendly:** thanks to the BlueBUS system, it allows the control unit to be connected to up to 7 pairs of photocells and control, security and signalling devices with just two wires.

**Built-in LED light:** programmable as either a flashing or courtesy light, it warns of gate movement during opening and closing.

**Master/slave selection:** for automatic synchronisation even of 2 motors, allowing automation of sliding gates with two opposing leaves.

**Intelligent:** thanks to obstacle detection and automatic working time programming. Self-diagnostics with flashing light signalling.

**Safe:** adjustable acceleration and deceleration at the start and end of every opening and closing operation.

### Built-in absolute limit stop:

- simple and precise regulation thanks to the rapid learning in a single movement with the motor released;
- no bracket or accessory to be installed on the ratchet;
- particularly suitable in snow areas.

**Practical:** control unit and optional PS124 buffer batteries can be connected by means of practical guided - connector.

CODE	DESCRIPTION	PACK/PALLET
SLH400KCE	KIT FOR THE AUTOMATION OF SLIDING GATES UP TO 400 Kg, IRREVERSIBLE, 24 Vdc, WITH BUILT-IN CONTROL UNIT AND ABSOLUTE ENCODER WITH BUILT-IN LED LIGHT	16

## TECHNICAL SPECIFICATIONS

CODE	SLH400
<b>ELECTRICAL DATA</b>	
POWER SUPPLY (Vac 50/60 Hz)	230
ABSORPTION (A)	1.1
POWER (W)	250
<b>PERFORMANCE DATA</b>	
SPEED (m/s)	0.34
FORCE (N)	400
WORK CYCLE (CYCLES/HOUR)	35
<b>DIMENSIONAL AND GENERAL DATA</b>	
PROTECTION LEVEL (IP)	44
WORKING TEMP. (°C MIN/MAX)	-20 ÷ +50
DIMENSIONS (mm)	191x198x408 h
WEIGHT (kg)	8

\* The protection degree of the automation is determined by the composition motor and column.

## DIMENSIONS

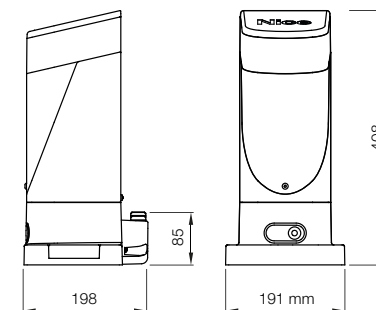

## THE KIT CONTAINS:

**SLH400**  
1 IRREVERSIBLE ELECTROMECHANICAL GEAR MOTOR, WITH BUILT-IN CONTROL UNIT AND ABSOLUTE ENCODER WITH BUILT-IN LED LIGHT



**ON2E**  
2 TRANSMITTERS  
433.92 MHz, 2 CHANNELS.



NEW

**EPMB**  
1 COUPLE OF EXTERNAL PHOTOCELLS DESIGNED FOR CONNECTION BY NICE BLUEBUS.



**OXI**  
RECEIVERS WITH CONNECTOR  
4 CHANNELS



NEW

**ELB**  
1 FLASHING LIGHT WITH INTEGRATED AERIAL.



**TS**  
1 SIGNBOARD.



## INSTALLATION DIAGRAM

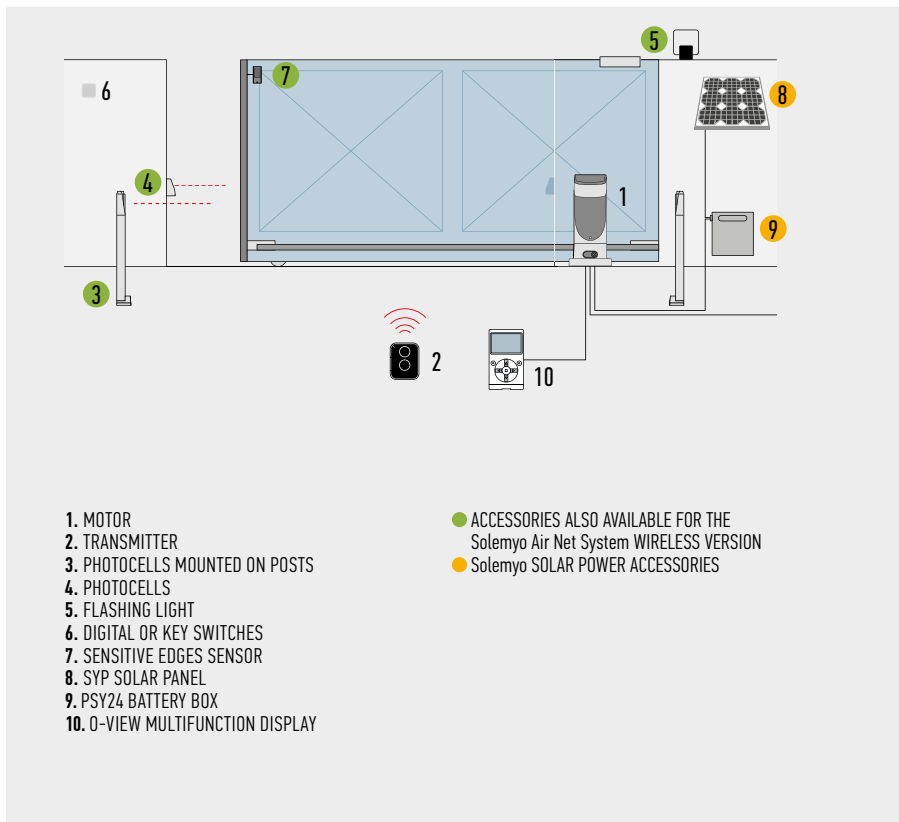

## ACCESSORIES



**NKA3**  
SPARE CONTROL UNIT.  
PC/PACK 1



**PS124**  
24 V BATTERY  
WITH INTEGRATED  
BATTERY CHARGER.  
PC/PACK 1



**ROA6**  
M4 25x20x1000 mm SLOTTED  
NYLON RACK WITH METAL  
INSERT FOR GATES  
WEIGHING UP TO 500 kg.  
PC/PACK 10



**ROA7**  
M4 RACK, ZINC COATED,  
22x22x1000 mm.  
PC/PACK 10



**ROA8**  
M4 RACK, 30x8x1000 mm,  
ZINC COATED WITH  
SPACERS AND SCREWS.  
PC/PACK 10



**K10**  
KEY-OPERATED SELECTOR  
SWITCH FOR LOW VOLTAGE  
CONTACTS, WITH RELEASE  
MECHANISM FOR METAL  
CORD.  
PC/PACK 1



**KA1**  
6 m CABLE RELEASE KIT  
FOR K10.  
PC/PACK 1



**KIT SOLEMYO**  
THE SOLAR POWER TO  
AUTOMATE GATES, GARAGE  
DOORS OR BARRIER GATES.  
SEE PAGE 200

FOR SWING GATES

FOR SLIDING GATES

BARRIER GATE  
OPERATOR SYSTEMS

FOR GARAGE  
AND INDUSTRIAL DOORS

CONTROL SYSTEMS  
AND ACCESSORIES

COMPATIBILITY TABLE  
AND ALPHABETICAL INDEX

# ROBUS 400/600/1000

SOLEMYO OPERA BLUEBUS 24V

**For sliding gates weighing up to 400 kg (RB400), up to 600 kg (RB600) and up to 1000 kg (RB1000).**

**Versions with electromechanical limit switch (RB400/RB600/RB1000) and with inductive limit switch (RB400P/RB600P/RB1000P).**

**User-friendly:** the Nice BlueBUS technology, enables to power and control a maximum of seven couples of photocells using two wires only.

**Practical:** the control unit and PS124 buffer battery (optional) can be connected by means of a simple connector and can be housed directly inside the motor.

**Advanced:** RB400, RB600 and RB1000 are equipped with a temperature sensor: adapt the motor power to the climatic conditions and at the same time thermal cut-out. A master/slave selection automatically synchronises two motors. This means it is possible to automate 2-leaf sliding gates set opposite each other.

**Intelligent:** thanks to the obstacle detection system and automatic programming of the working times. Self-diagnosis by means of a flashing light. 8 programming levels.

**Safe:** acceleration and deceleration can be adjusted at the beginning and end of each opening and closing manoeuvre.

**Sturdy:** base and release in pressure die cast with easy to open handle.

**Very quiet:** gear motor on bearings.

ALUMINIUM RELEASE HANDLE FOR EASY OPENING

COMPARTMENT FOR THE PULL-OUT CONTROL UNIT, PROTECTED BY CASING, AND FOR BUFFER BATTERIES



CODE	DESCRIPTION	PACK/PALLET
<b>RB400</b>	IRREVERSIBLE, 24 Vdc, WITH INCORPORATED CONTROL UNIT, WITH ELECTROMECHANICAL LIMIT SWITCH, FOR GATES UP TO 400 kg	15
<b>RB600</b>	IRREVERSIBLE, 24 Vdc, WITH INCORPORATED CONTROL UNIT, WITH ELECTROMECHANICAL LIMIT SWITCH, FOR GATES UP TO 600 kg	15
<b>RB600P</b>	IRREVERSIBLE, 24 Vdc, WITH INCORPORATED CONTROL UNIT, WITH INDUCTIVE LIMIT SWITCH, FOR GATES UP TO 600 kg	15
<b>RB1000</b>	IRREVERSIBLE, 24 Vdc, WITH INCORPORATED CONTROL UNIT, WITH ELECTROMECHANICAL LIMIT SWITCH, FOR GATES UP TO 1000 kg	15
<b>RB1000P</b>	IRREVERSIBLE, 24 Vdc, WITH INCORPORATED CONTROL UNIT, WITH INDUCTIVE LIMIT SWITCH, FOR GATES UP TO 1000 kg	15

## TECHNICAL SPECIFICATIONS

CODE	RB400	RB600/600P	RB1000/1000P
<b>ELECTRICAL DATA</b>			
POWER SUPPLY (Vac 50/60 Hz)	230		
ABSORPTION (A)	1.1	2.5	2.3
POWER (W)	250	515	450
<b>PERFORMANCE DATA</b>			
SPEED (m/s)	0.34	0.31	0.28
FORCE (N)	400	600	900
WORK CYCLE (CYCLES/HOUR)	35	40	50
<b>DIMENSIONAL AND GENERAL DATA</b>			
PROTECTION LEVEL (IP)	44		
WORKING TEMP. (°C MIN/MAX)	-20 ÷ +50		
DIMENSIONS (mm)	330x195x277 h	330x210x303 h	
WEIGHT (kg)	8	11	13

## DIMENSIONS

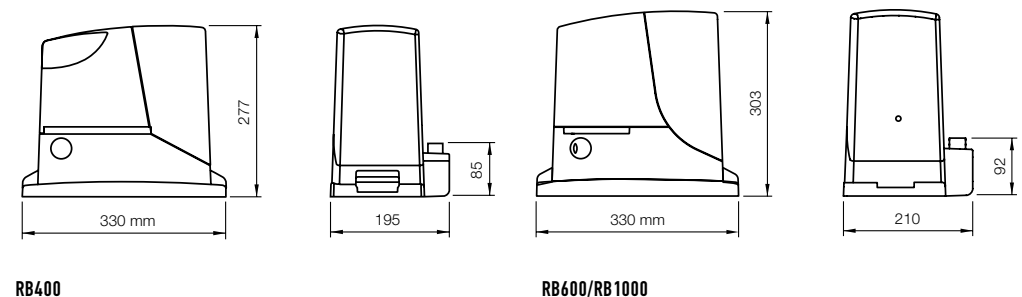

## INSTALLATION DIAGRAM

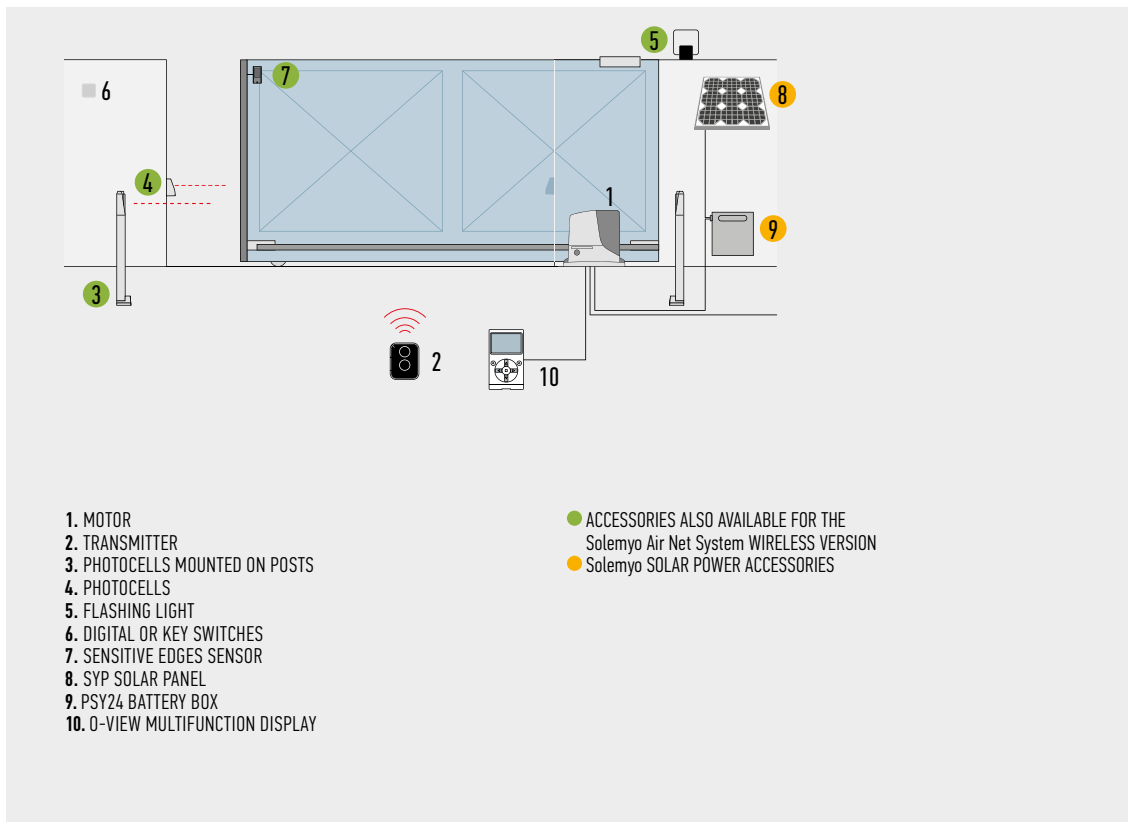

## COMPATIBILITY TABLE WITH CONTROL SYSTEMS AND ACCESSORIES

CODE	RECEIVER		TRANSMITTER				PHOTOCELLS							FLASHING LIGHT								
	Built-in*	FLOX12R*	OXI	ERA INTI	ERA ONE	ERA FLOR	NICEWAY	EPS	EPM	EPL	EPSB	EPMB	EPLB	F210	FT210	F210B	F210B	EL	EL24	ELB	WLT	
<b>RB400</b>			●																			
<b>RB600/600P</b>			●	●	●	●	●				●	●	●			●	●			●	●	
<b>RB1000/1000P</b>			●	●	●	●	●				●	●	●			●	●			●	●	

\*Radio receiver incompatible with Opera system

## ACCESSORIES

**RBA3**  
SPARE CONTROL UNIT FOR RB400, RB600/600P, RB1000/1000P AND RUN1500/1500P.  
PC/PACK 1

**PS124**  
24 V BATTERY WITH INTEGRATED BATTERY CHARGER.  
PC/PACK 1

**RBA1**  
INDUCTIVE LIMIT SWITCH.  
PC/PACK 1

**ROA6**  
(FOR RB400)  
M4 25x20x1000 mm SLOTTED NYLON RACK WITH METAL INSERT FOR GATES WEIGHING UP TO 500 kg.  
PC/PACK 10

**ROA7**  
M4 RACK, ZINC COATED, 22x22x1000 mm.  
PC/PACK 10

**ROA8**  
M4 RACK, 30x8x1000 mm, ZINC COATED WITH SPACERS AND SCREWS.  
PC/PACK 10

**TS**  
SIGNBOARD.  
PC/PACK 1



**KIT SOLEMYO**  
THE SOLAR POWER TO AUTOMATE GATES, GARAGE DOORS OR BARRIER GATES. SEE PAGE 200

FOR SWING GATES

FOR SLIDING GATES

BARRIER GATE OPERATOR SYSTEMS

FOR GARAGE AND INDUSTRIAL DOORS

CONTROL SYSTEMS AND ACCESSORIES

COMPATIBILITY TABLE AND ALPHABETICAL INDEX

# ROBUSKIT 400

SOLEMYO OPERA BLUEBUS 24V

## For sliding gates weighing up to 400 kg.

**User-friendly:** the Nice BlueBUS technology, enables to power and control a maximum of seven couples of photocells using two wires only.

**Practical:** the control unit and PS124 buffer battery (optional) can be connected by means of a simple connector and can be housed directly inside Robus.

**Advanced:** RB400 is equipped with a temperature sensor: adapt the motor power to the climatic conditions and at the same time thermal cut-out.  
A master/slave selection automatically synchronises two motors. This means it is possible to automate 2-leaf sliding gates set opposite each other.

**Intelligent:** thanks to the obstacle detection system and automatic programming of the working times. Self-diagnosis by means of a flashing light. 8 programming levels.

**Safe:** acceleration and deceleration can be adjusted at the beginning and end of each opening and closing manoeuvre.

**Sturdy:** base and release in pressure die cast aluminium and epoxy paint finish.

**Very quiet:** gear motor on bearings.



**The new Era Gate accessories,** with a minimal, modern and discreet design, renovate Nice kits' style and performance.

Discover the complete range at page 184

CODE	DESCRIPTION	PACK/PALLET
RB400KCE	KIT FOR THE AUTOMATION OF SLIDING GATES UP TO 400 kg, 24 Vdc, INCORPORATED CONTROL UNIT	14

**N.B.** The content of the package may vary; consult the retailer.

## TECHNICAL SPECIFICATIONS

CODE	RB400
<b>ELECTRICAL DATA</b>	
POWER SUPPLY (Vac 50/60 Hz)	230
ABSORPTION (A)	1.1
POWER (W)	250
<b>PERFORMANCE DATA</b>	
SPEED (m/s)	0.34
FORCE (N)	400
WORK CYCLE (CYCLES/HOUR)	35
<b>DIMENSIONAL AND GENERAL DATA</b>	
PROTECTION LEVEL (IP)	44
WORKING TEMP. (°C MIN/MAX)	-20 ÷ +50
DIMENSIONS (mm)	330x195x277 h
WEIGHT (kg)	8

## DIMENSIONS

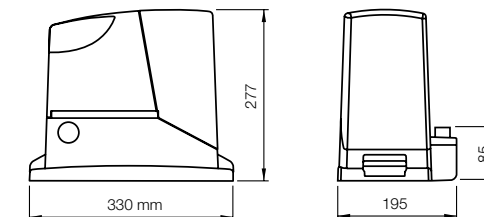

## THE KIT CONTAINS:

**RB400**  
1 IRREVERSIBLE ELECTROMECHANICAL GEAR MOTOR, WITH INCORPORATED CONTROL UNIT AND OXI PLUG-IN RECEIVER WHICH CAN BE USED FOR CONNECTIONS VIA NICE BLUEBUS.



**ON2E**  
1 TRANSMITTER  
433.92 MHz, 2 CHANNELS.



**EPMB**  
1 COUPLE OF EXTERNAL PHOTOCELLS DESIGNED FOR CONNECTION BY NICE BLUEBUS.



**EKS**  
1 KEY SELECTOR SWITCH FOR OUTDOOR INSTALLATION.



**ELB**  
1 FLASHING LIGHT WITH INTEGRATED AERIAL.



**TS**  
1 SIGNBOARD.



## INSTALLATION DIAGRAM

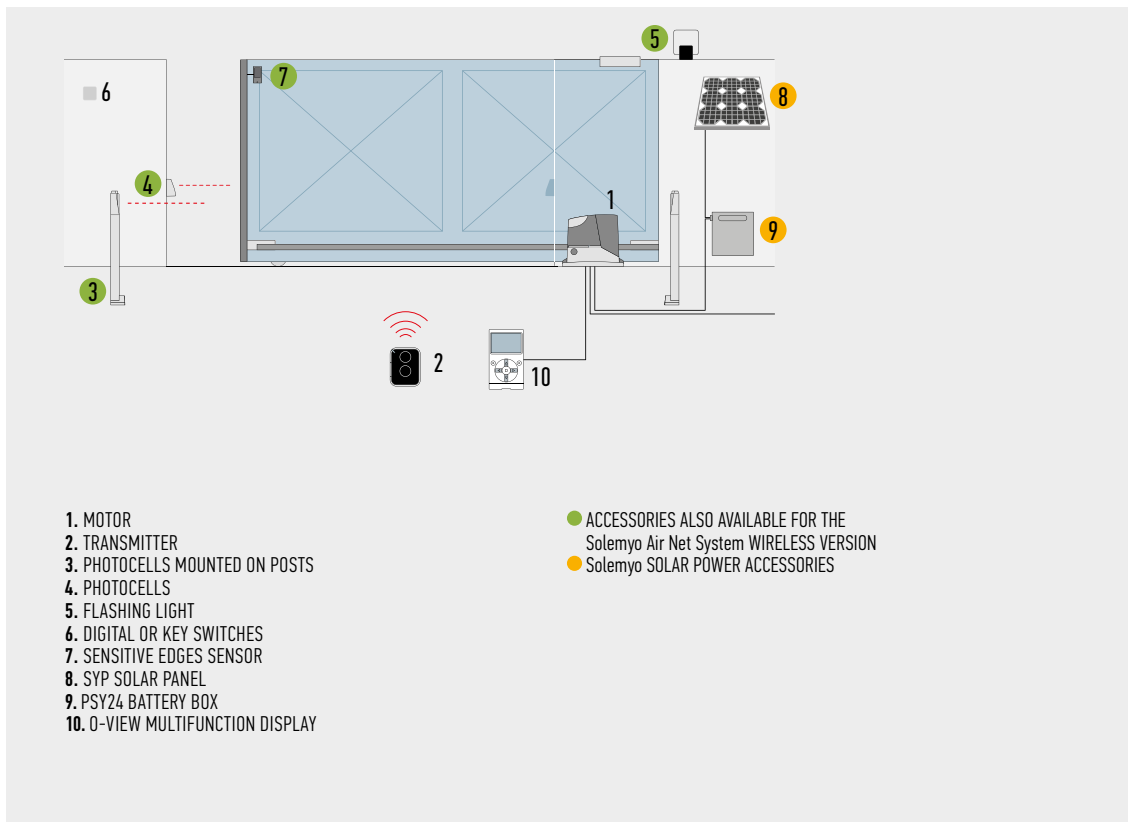

Nice recommends customers order products in pallets in order to facilitate storage and delivery, and ensure packs are uniform. The number of packs per single pallet has been specified for this reason. Approximate draft.

## ACCESSORIES



**RBA3**  
 SPARE CONTROL UNIT  
 FOR RB400, RB600/600P,  
 RB1000/1000P  
 AND RUN1500/1500P.  
 PC/PACK 1



**PS124**  
 24 V BATTERY  
 WITH INTEGRATED  
 BATTERY CHARGER.  
 PC/PACK 1



**RBA1**  
 INDUCTIVE LIMIT SWITCH.  
 PC/PACK 1



**ROA6**  
 M4 25x20x1000 mm SLOTTED  
 NYLON RACK WITH METAL  
 INSERT FOR GATES WEIGHING  
 UP TO 500 kg.  
 PC/PACK 10



**ROA7**  
 M4 RACK, ZINC COATED,  
 22x22x1000 mm.  
 PC/PACK 10



**ROA8**  
 M4 RACK, 30x8x1000 mm,  
 ZINC COATED WITH SPACERS  
 AND SCREWS.  
 PC/PACK 10



**KIT SOLEMYO**  
 THE SOLAR POWER TO  
 AUTOMATE GATES, GARAGE  
 DOORS OR BARRIER GATES.  
 SEE PAGE 200

FOR SWING GATES

FOR SLIDING GATES

BARRIER GATE  
 OPERATOR SYSTEMS

FOR GARAGE  
 AND INDUSTRIAL DOORS

CONTROL SYSTEMS  
 AND ACCESSORIES

COMPATIBILITY TABLE  
 AND ALPHABETICAL INDEX

# ROBUSKIT 600

SOLEMYO OPERA BLUEBUS 24V

## For sliding gates weighing up to 600 kg.

**User-friendly:** the Nice BlueBUS technology, enables to power and control a maximum of seven couples of photocells using two wires only.

**Practical:** the control unit and PS124 buffer battery (optional) can be connected by means of a simple connector and can be housed directly inside the motor.

**Advanced:** RB600 is equipped with a temperature sensor: adapt the motor power to the climatic conditions and at the same time thermal cut-out; a master/slave selection automatically synchronises two motors. This means it is possible to automate 2-leaf sliding gates set opposite each other.

**Intelligent:** thanks to the obstacle detection system and automatic programming of the working times. Self-diagnosis by means of a flashing light. 8 programming levels.

**Safe:** acceleration and deceleration can be adjusted at the beginning and end of each opening and closing manoeuvre.

**Sturdy:** base and release in pressure die cast with easy to open handle.

**Very quiet:** gear motor on bearings.



**The new Era Gate accessories,** with a minimal, modern and discreet design, renovate Nice kits' style and performance.

Discover the complete range at page 184

CODE	DESCRIPTION	PACK/PALLET
RB600KCE	KIT FOR THE AUTOMATION OF SLIDING GATES UP TO 600 kg, 24 Vdc, INCORPORATED CONTROL UNIT	14

**N.B.** The content of the package may vary; consult the retailer.

## TECHNICAL SPECIFICATIONS

CODE	RB600
<b>ELECTRICAL DATA</b>	
POWER SUPPLY (Vac 50/60 Hz)	230
ABSORPTION (A)	2.5
POWER (W)	515
<b>PERFORMANCE DATA</b>	
SPEED (m/s)	0.31
FORCE (N)	600
WORK CYCLE (CYCLES/HOUR)	40
<b>DIMENSIONAL AND GENERAL DATA</b>	
PROTECTION LEVEL (IP)	44
WORKING TEMP. (°C MIN/MAX)	-20 ÷ +50
DIMENSIONS (mm)	330x210x303 h
WEIGHT (kg)	11

## DIMENSIONS

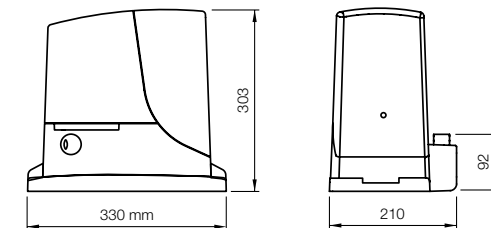

## THE KIT CONTAINS:

**RB600**  
1 IRREVERSIBLE ELECTROMECHANICAL GEAR MOTOR, 1 WITH INCORPORATED CONTROL UNIT AND OXI PLUG-IN RECEIVER WHICH CAN BE USED FOR CONNECTIONS VIA NICE BLUEBUS.



**ON2E**  
1 TRANSMITTER 433.92 MHz, 2 CHANNELS.



**EPMB**  
1 COUPLE OF EXTERNAL PHOTOCELLS DESIGNED FOR CONNECTION BY NICE BLUEBUS.



**EKS**  
1 KEY SELECTOR SWITCH FOR OUTDOOR INSTALLATION.



**ELB**  
1 FLASHING LIGHT WITH INTEGRATED AERIAL.



**TS**  
1 SIGNBOARD.





## INSTALLATION DIAGRAM

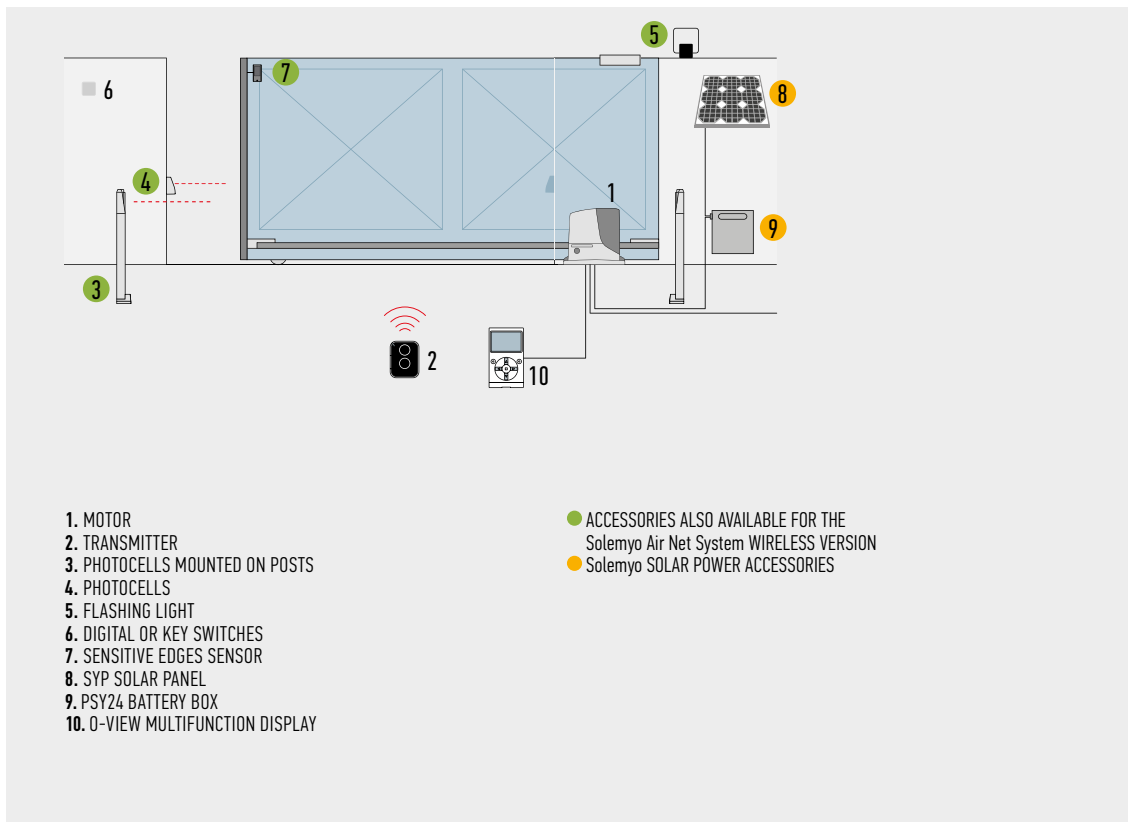

Nice recommends customers order products in pallets in order to facilitate storage and delivery, and ensure packs are uniform. The number of packs per single pallet has been specified for this reason. Approximate draft.

## ACCESSORIES



**RBA3**  
 SPARE CONTROL UNIT  
 FOR RB400, RB600/600P,  
 RB1000/1000P  
 AND RUN1500/1500P.  
 PC/PACK 1



**PS124**  
 24 V BATTERY  
 WITH INTEGRATED  
 BATTERY CHARGER.  
 PC/PACK 1



**RBA1**  
 INDUCTIVE LIMIT SWITCH.  
 PC/PACK 1



**ROA7**  
 M4 RACK, ZINC COATED,  
 22x22x1000 mm.  
 PC/PACK 10



**ROA8**  
 M4 RACK, 30x8x1000 mm,  
 ZINC COATED WITH  
 SPACERS AND SCREWS.  
 PC/PACK 10



**KIT SOLEMYO**  
 THE SOLAR POWER TO  
 AUTOMATE GATES, GARAGE  
 DOORS OR BARRIER GATES.  
 SEE PAGE 200

FOR SWING GATES

FOR SLIDING GATES

BARRIER GATE  
 OPERATOR SYSTEMS

FOR GARAGE  
 AND INDUSTRIAL DOORS

CONTROL SYSTEMS  
 AND ACCESSORIES

COMPATIBILITY TABLE  
 AND ALPHABETICAL INDEX

# ROADKIT

24V

## For sliding gates weighing up to 400 kg.

**Practical:** built-in control unit, can be connected by means of a simple connector and can be housed directly inside the motor; incorporated radio card, compatible with the Nice Flo and Smilo systems: 150 transmitters can be entered!

**Advanced:** the speed, strength and pause can all be adjusted.

**Intelligent:** thanks to the obstacle detection system and automatic programming of the working times. Self-diagnosis by means of a flashing light.

**Practical:** the control unit and PS124 buffer battery (optional) can be connected by means of a simple connector and can be housed directly inside the motor.



**The new Era Gate accessories,** with a minimal, modern and discreet design, renovate Nice kits' style and performance.

Discover the complete range at page 184

CODE	DESCRIPTION
<b>RD400</b>	KIT FOR THE AUTOMATION OF SLIDING GATES UP TO 400 kg AND UP TO 6 m LENGTH, 24 Vdc, WITH INCORPORATED CONTROL UNIT AND RECEIVER

**N.B.** The content of the package may vary; consult the retailer.

### TECHNICAL SPECIFICATIONS

CODE	RD400
<b>ELECTRICAL DATA</b>	
POWER SUPPLY (Vac 50/60 Hz)	230
ABSORPTION (A)	1.1
POWER (W)	210
<b>PERFORMANCE DATA</b>	
SPEED (m/s)	0.25
FORCE (N)	400
WORK CYCLE (CYCLES/HOUR)	20
<b>DIMENSIONAL AND GENERAL DATA</b>	
PROTECTION LEVEL (IP)	44
WORKING TEMP. (°C MIN/MAX)	-20 ÷ +50
DIMENSIONS (mm)	330x195x277 h
WEIGHT (kg)	8

### DIMENSIONS

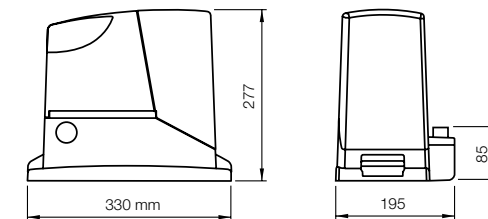

### THE KIT CONTAINS:

**RD400**  
1 IRREVERSIBLE ELECTROMECHANICAL GEAR MOTOR, 24 Vdc, WITH INCORPORATED CONTROL UNIT AND RECEIVER.



**FL02RE**  
1 TRANSMITTER 433.92 MHz, 2 CHANNELS.



**EPM**  
1 PAIR OF PHOTOCELLS FOR OUTDOOR INSTALLATION.



**EKS**  
1 KEY SELECTOR SWITCH FOR OUTDOOR INSTALLATION.



**ELB**  
1 FLASHING LIGHT WITH INTEGRATED AERIAL.



**TS**  
1 SIGNBOARD.



## INSTALLATION DIAGRAM

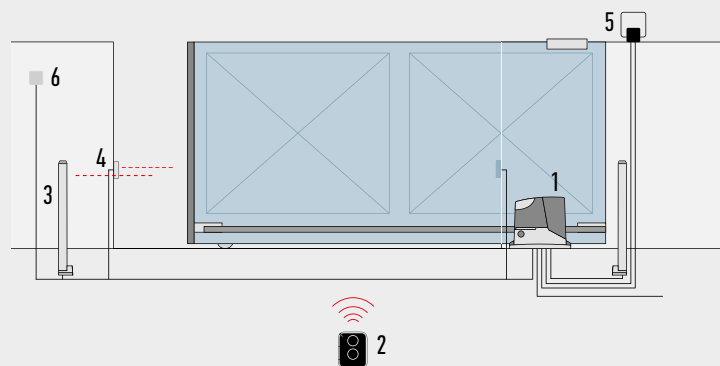

1. MOTOR
2. TRANSMITTER
3. PHOTOCELLS MOUNTED ON POSTS
4. PHOTOCELLS
5. FLASHING LIGHT
6. DIGITAL OR KEY SWITCHES

## ACCESSORIES



**RBA4**  
SPARE CONTROL UNIT  
FOR RDKCE.



**PS124**  
24 V BATTERY  
WITH INTEGRATED  
BATTERY CHARGER.

PC/PACK 1



**CM-B**  
PAWL WITH TWO METAL  
RELEASE KEYS.



**ROA6**  
M4 25X20X1000 mm SLOTTED  
NYLON RACK WITH METAL  
INSERT FOR GATES WEIGHING  
UP TO 500 kg.

PC/PACK 10



**ROA7**  
M4 RACK, ZINC COATED,  
22X22X1000 mm.

PC/PACK 10



**ROA8**  
M4 RACK, 30X8X1000 mm,  
ZINC COATED WITH  
SPACERS AND SCREWS.

PC/PACK 10

FOR SWING GATES

FOR SLIDING GATES

BARRIER GATE  
OPERATOR SYSTEMS

FOR GARAGE  
AND INDUSTRIAL DOORS

CONTROL SYSTEMS  
AND ACCESSORIES

COMPATIBILITY TABLE  
AND ALPHABETICAL INDEX

# RUN 1500

SOLEMYO OPERA BLUEBUS 24V

**For sliding gates weighing up to 1500 kg.**

**Versions with electromechanical limit switch (RUN1500) and with inductive limit switch (RUN1500P).**

**User-friendly:** the BlueBUS technology, enables to power and control a maximum of 7 couples of photocells using two wires only.

**Practical:** the control unit and PS124 buffer battery (optional) can be connected by means of a simple connector and can be housed directly inside the motor.

**Advanced:** the temperature sensor adapts the motor force to weather conditions, setting the thermal cut-out protection accordingly; a master/slave selection automatically synchronises 2 motors, enabling the automation of sliding gates with two opposing leaves.

**Intelligent:** thanks to the obstacle detection system and automatic programming of the working times. Self-diagnosis by means of a flashing light. 8 programming levels.

**Safe:** acceleration and deceleration can be adjusted at the beginning and end of each opening and closing manoeuvre.

**Sturdy:** aluminium release handle for easy opening.

**Very quiet:** gear motor on bearings.



COMPARTMENT FOR CONTROL UNIT PROTECTED BY REMOVABLE BOX

PRESSURE DIE-CAST ALUMINIUM BASE AND RELEASE, WITH EPOXY PAINTING

CODE	DESCRIPTION	PACK/PALLET
RUN1500	IRREVERSIBLE, 24 Vdc, WITH BUILT-IN CONTROL UNIT, WITH ELECTROMECHANICAL LIMIT SWITCH, FOR SLIDING GATES WEIGHING UP TO 1500 kg	12
RUN1500P	IRREVERSIBLE, 24 Vdc, WITH BUILT-IN CONTROL UNIT, WITH INDUCTIVE LIMIT SWITCH, FOR SLIDING GATES WEIGHING UP TO 1500 kg	12

## TECHNICAL SPECIFICATIONS

CODE	RUN1500/1500P
<b>ELECTRICAL DATA</b>	
POWER SUPPLY (Vac 50/60 Hz)	230
ABSORPTION (A)	2
POWER (W)	400
<b>PERFORMANCE DATA</b>	
SPEED (m/s)	0.25
FORCE (N)	1000
WORK CYCLE (CYCLES/HOUR)	60
<b>DIMENSIONAL AND GENERAL DATA</b>	
PROTECTION LEVEL (IP)	44
WORKING TEMP. (°C MIN/MAX)	-20 ÷ +50
DIMENSIONS (mm)	400x255x390 h
WEIGHT (kg)	19

## DIMENSIONS

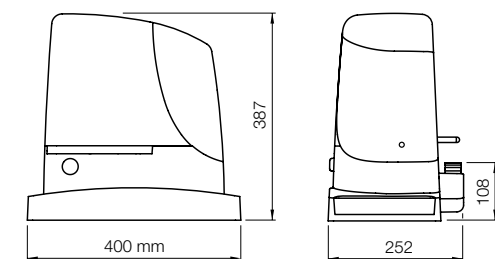

## INSTALLATION DIAGRAM

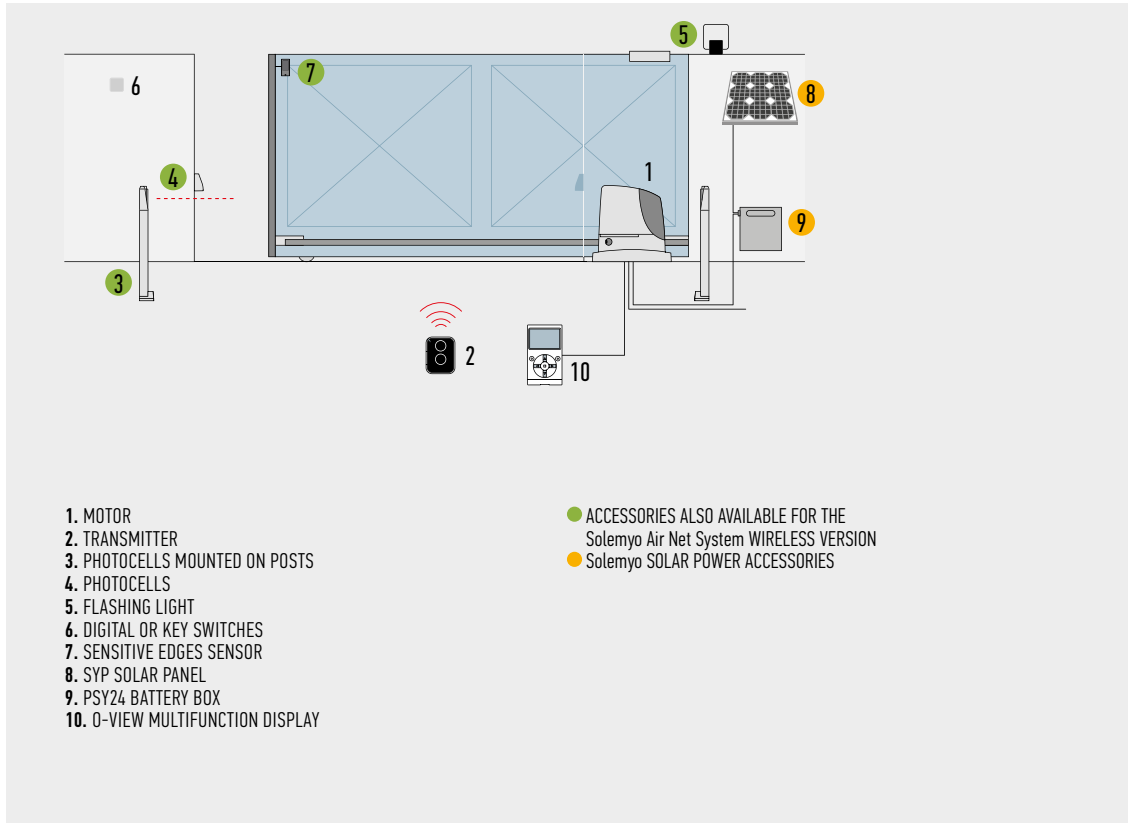

## COMPATIBILITY TABLE WITH CONTROL SYSTEMS AND ACCESSORIES

CODE	RECEIVER			TRANSMITTER				PHOTOCELLS						FLASHING LIGHT							
	Built-in*	FLOX2R*	OXI	ERA INTI	ERA ONE	ERA FLOR	NICEWAY	EPS	EPM	EPL	EPSB	EPMB	EPLB	F210	FT210	F210B	FT210B	EL	EL24	ELB	WLT
RUN1500/1500P			●	●	●	●	●				●	●	●			●	●			●	●

\*Radio receiver incompatible with Opera system

## ACCESSORIES

**RBA3**  
 SPARE CONTROL UNIT FOR RB400, RB600/600P, RB1000/1000P AND RUN1500/1500P.  
 PC/PACK 1

**PS124**  
 24 V BATTERY WITH INTEGRATED BATTERY CHARGER.  
 PC/PACK 1

**RBA1**  
 INDUCTIVE LIMIT SWITCH.  
 PC/PACK 1

**ROA7**  
 M4 RACK, ZINC COATED, 22X22X1000 mm.  
 PC/PACK 10

**ROA8**  
 M4 RACK, 30X8X1000 mm, ZINC COATED WITH SPACERS AND SCREWS.  
 PC/PACK 10

**ROA81**  
 M6 RACK, 30X30X1000 mm, ZINC COATED, TO BE COUPLED WITH RUA12.  
 PC/PACK 1

**RUA12**  
 12-TEETH PINION, MODULE 6, TO BE COUPLED WITH RACK ROA81.  
 The Run automation is supplied with a module 4 pinion to be used with the standard racks ROA7 and ROA8.  
 PC/PACK 1

**TS**  
 SIGNBOARD.  
 PC/PACK 1



**KIT SOLEMYO**  
 THE SOLAR POWER TO AUTOMATE GATES, GARAGE DOORS OR BARRIER GATES. SEE PAGE 200

Nice recommends customers order products in pallets in order to facilitate storage and delivery, and ensure packs are uniform. The number of packs per single pallet has been specified for this reason. Approximate draft.

FOR SWING GATES

FOR SLIDING GATES

BARRIER GATE OPERATOR SYSTEMS

FOR GARAGE AND INDUSTRIAL DOORS

CONTROL SYSTEMS AND ACCESSORIES

COMPATIBILITY TABLE AND ALPHABETICAL INDEX

# RUN 1800/2500

OPERA BLUEBUS 230V

**For sliding gates weighing up to 1800 kg (RUN1800) and up to 2500 kg (RUN2500).**

**Ventilated motor with inductive limit switch (RUN1800P/RUN2500P) or electromechanical limit switch (RUN1800/RUN2500I/RUN2500).**

**Suitable to operate in extreme conditions, in systems for intensive use.**

**Simple to install:** the BlueBUS system enables connections by means of just two wires between the control unit and up to 15 control safety and signalling devices.

**Safe:** the acceleration settings (at the start of the manoeuvre) and the deceleration settings (at the end of the manoeuvre) are precise and reliable.

**The temperature sensor:** Run is able to manage force, adapting it to the different climatic and environmental conditions, while adapting the thermal cut-out protection and intensity of self-ventilation, depending on the temperature reading.

A **master/slave** selection also automatically synchronises 2 motors, enabling the automation of sliding gates with two opposing leaves.

**Practical and functional:** the control unit (and inverter on version RUN2500I), housed inside Run, can be simply connected by means of the practical connector guide.

**Very quiet:** gear motor on bearings.

## RUN2500I version with built-in inverter

**Perfect movement:** the inverter enables the power supply and drive of the 3-phase motor with single-phase current at 230 Vac, acting on the frequency to adjust speed of the automation from a minimum of 8.2 m/min to maximum 15.4 m/min.

In the automation deceleration phase, the inverter, which dialogues with the control unit, increases the torque, thus improving performance and reducing the risk of the automation blocking on impact with obstacles.

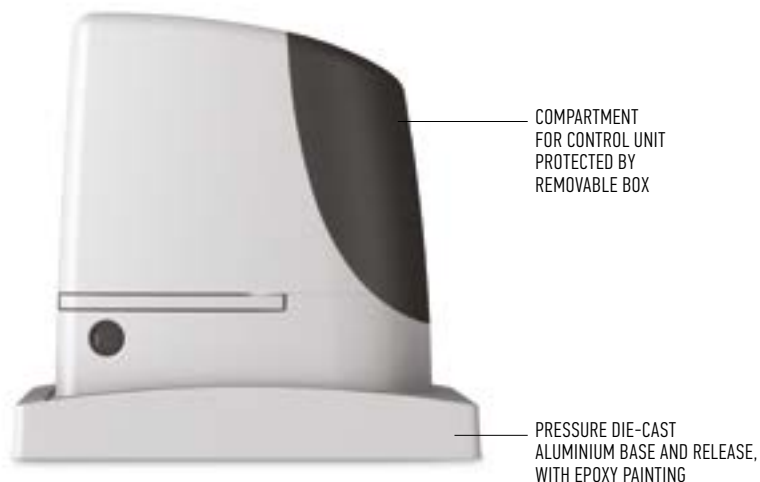

CODE	DESCRIPTION	PACK/PALLET
<b>RUN1800</b>	IRREVERSIBLE, 230 Vac, WITH BUILT-IN CONTROL UNIT, WITH ELECTROMECHANICAL LIMIT SWITCH, FOR SLIDING GATES WEIGHING UP TO 1800 kg	12
<b>RUN1800P</b>	IRREVERSIBLE, 230 Vac, WITH BUILT-IN CONTROL UNIT, WITH INDUCTIVE LIMIT SWITCH, FOR SLIDING GATES WEIGHING UP TO 1800 kg	12
<b>RUN2500</b>	IRREVERSIBLE, 230 Vac, WITH BUILT-IN CONTROL UNIT, WITH ELECTROMECHANICAL LIMIT SWITCH, FOR SLIDING GATES WEIGHING UP TO 2500 kg	12
<b>RUN2500P</b>	IRREVERSIBLE, 230 Vac, WITH BUILT-IN CONTROL UNIT, WITH INDUCTIVE LIMIT SWITCH, FOR SLIDING GATES WEIGHING UP TO 2500 kg	12
<b>RUN2500I</b>	IRREVERSIBLE, 230 Vac, WITH BUILT-IN CONTROL UNIT AND INVERTER, WITH ELECTROMECHANICAL LIMIT SWITCHES, FOR SLIDING GATES WEIGHING UP TO 2500 kg	12

## TECHNICAL SPECIFICATIONS

CODE	RUN1800/1800P	RUN2500/2500P	RUN2500I
<b>ELECTRICAL DATA</b>			
POWER SUPPLY (Vac/Hz)	230/50*		230/50-60
ABSORPTION (A)	3	3.8	3.7
POWER (W)	700	870	650
<b>PERFORMANCE DATA</b>			
SPEED (m/s)	0.17		0.26
FORCE (N)	1110	1390	1660
WORK CYCLE (CYCLES/HOUR)	42		56
<b>DIMENSIONAL AND GENERAL DATA</b>			
PROTECTION LEVEL (IP)	44		
WORKING TEMP. (°C MIN/MAX)	-20 ÷ +50		
DIMENSIONS (mm)	400x255x390 h		
WEIGHT (kg)	24.5		25

\*60 Hz version available on request.

## DIMENSIONS

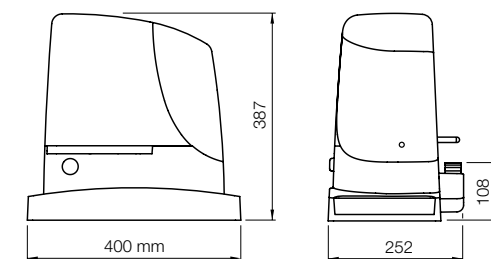

## INSTALLATION DIAGRAM

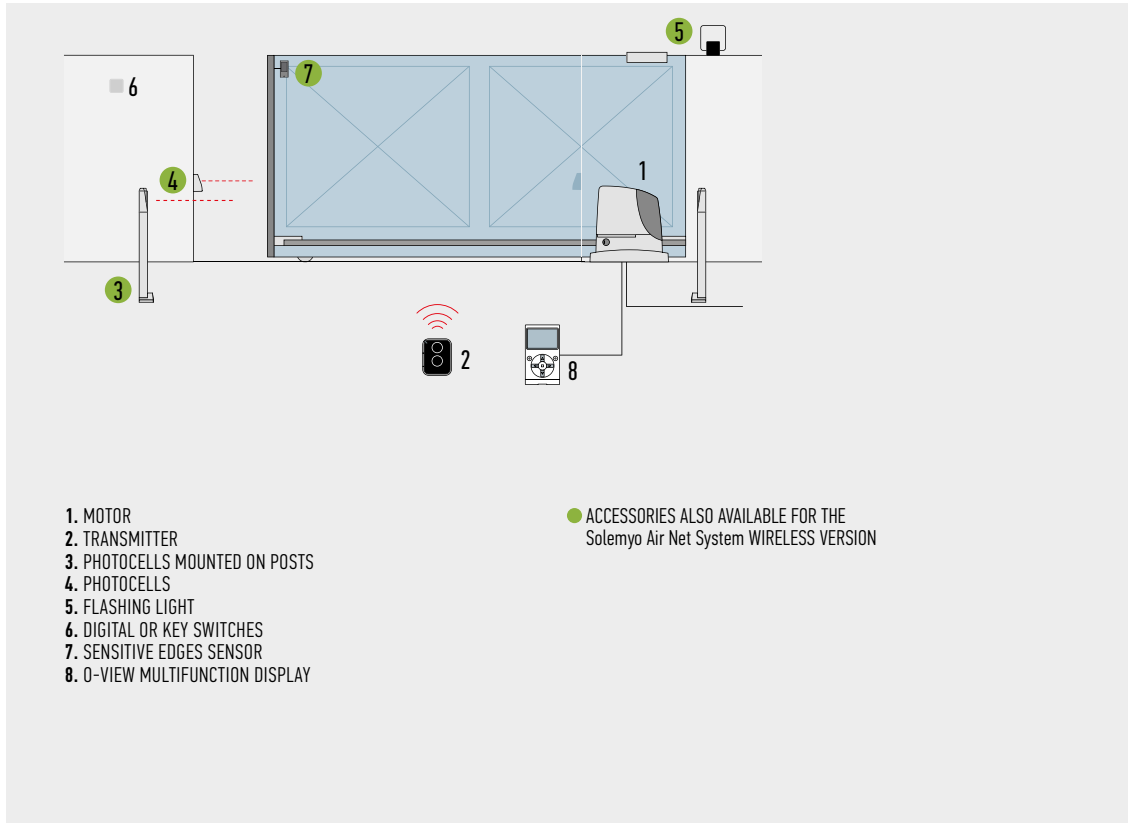

## COMPATIBILITY TABLE WITH CONTROL SYSTEMS AND ACCESSORIES

CODE	RECEIVER			TRANSMITTER				PHOTOCELLS						FLASHING LIGHT							
	Built-in*	FLOX2R*	OXI	ERA INTI	ERA ONE	ERA FLOR	NICEWAY	EPS	EPM	EPL	EPSB	EPMB	EPLB	F210	FT210	F210B	FT210B	EL	EL24	ELB	WLT
RUN1800/1800P			●	●	●	●	●				●	●	●			●	●			●	●
RUN2500/2500P			●	●	●	●	●				●	●	●			●	●			●	●
RUN2500I			●	●	●	●	●				●	●	●			●	●			●	●

\*Radio receiver incompatible with Opera system

## ACCESSORIES

**RUA1**  
SPARE CONTROL UNIT FOR RUN1800/1800P AND RUN2500/2500P.  
PC/PACK 1

**RUA2**  
SPARE CONTROL UNIT FOR RUN2500I.  
PC/PACK 1

**RUA3**  
SPARE INVERTER FOR RUN2500I.  
PC/PACK 1

**ROA7**  
M4 RACK, ZINC COATED, 22X22X1000 mm.  
PC/PACK 10

**ROA8**  
M4 RACK, 30X8X1000 mm, ZINC COATED WITH SPACERS AND SCREWS.  
PC/PACK 10

**ROA81**  
M6 RACK, 30X30X1000 mm, ZINC COATED, TO BE COUPLED WITH RUA12.  
PC/PACK 1

**RUA12**  
12-TEETH PINION, MODULE 6, TO BE COUPLED WITH RACK ROA81. The Run automation is supplied with a module 4 pinion to be used with the standard racks ROA7 and ROA8.  
PC/PACK 1

**TS**  
SIGNBOARD.  
PC/PACK 1

Nice recommends customers order products in pallets in order to facilitate storage and delivery, and ensure packs are uniform. The number of packs per single pallet has been specified for this reason. Approximate draft.

FOR SWING GATES  
FOR SLIDING GATES  
BARRIER GATE OPERATOR SYSTEMS  
FOR GARAGE AND INDUSTRIAL DOORS  
CONTROL SYSTEMS AND ACCESSORIES  
COMPATIBILITY TABLE AND ALPHABETICAL INDEX

# TUB

400V

## For sliding gates weighing up to 3500 kg. Ideal for industrial use.

Irreversible electromechanical 400 Vac gear motor with built-in Mindy A500 control unit.

### Powerful:

550 W absorbed output and a peak thrust of over 400 Nm.

### Functionality and safety:

programmable, electronic brake which prevents gate inertia; self-ventilated motor to increase the working cycles; optional PIU card to increase the basic functions.

### Maximum durability and silence:

bronze and metal gears.

### Advanced:

Tub meets all requirements in terms of control, thanks to the functions which can be selected by means of dipswitches.

### Practical:

the lever release enables safe and simple operation.



CODE	DESCRIPTION
<b>TUB3500</b>	IRREVERSIBLE, ELECTROMECHANICAL LIMIT SWITCH, 400 Vac, WITH BUILT-IN MINDY A500 CONTROL UNIT

### TECHNICAL SPECIFICATIONS

CODE	TUB3500
<b>ELECTRICAL DATA</b>	
POWER SUPPLY (Vac 50 Hz)*	400
ABSORPTION (A)	1.65
POWER (W)	550
<b>PERFORMANCE DATA</b>	
SPEED (m/s)	0.17
FORCE (N)	7740
WORK CYCLE (CYCLES/DAY)	200
<b>DIMENSIONAL AND GENERAL DATA</b>	
PROTECTION LEVEL (IP)	44
WORKING TEMP. (°C MIN/MAX)	-20 ÷ +50
DIMENSIONS (mm)	480x240x580 h
WEIGHT (kg)	60

### DIMENSIONS

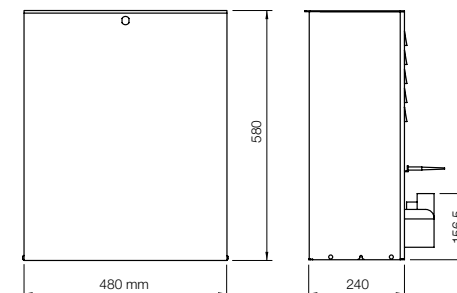

\*Usable also at 60 Hz with consequent change in performance ratings.

### INSTALLATION DIAGRAM

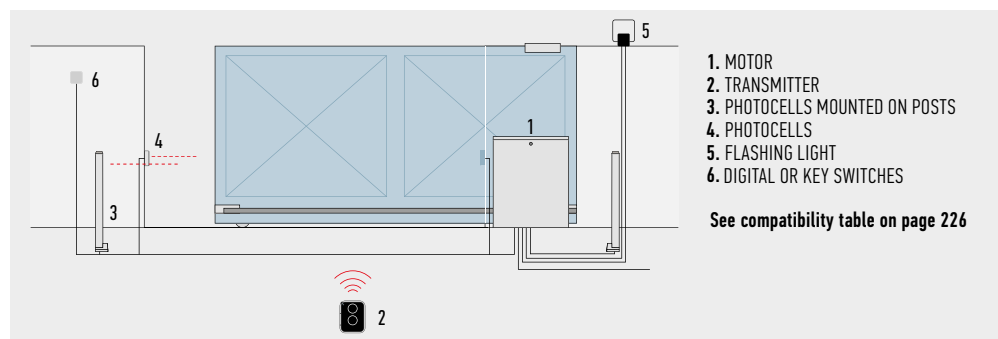

### ACCESSORIES



**A500**  
SPARE CONTROL UNIT.  
PC/PACK 1



**PIU**  
EXPANSION CARD  
FOR CONTROL UNIT.  
PC/PACK 1



**ROA81**  
M6 RACK, 30x30x1000 mm,  
ZINC COATED.  
PC/PACK 1



**TS**  
SIGNBOARD.  
PC/PACK 1





# RACKS

**For sliding gates or on motors with pinion.**

Plastic racks are available for gates up to 500 kg (ROA6) and **galvanised** racks, ideal for any type of sliding gate, residential and industrial: ROA7 for direct welding on the gate, and the **practical** ROA8 (the spacers are welded onto the gate, and then the rack is screwed onto the spacers).



**ROA6**  
M4 25x20x1000 mm SLOTTED NYLON RACK WITH METAL INSERT FOR GATES WEIGHING UP TO 500 kg.  
PC/PACK 10



**ROA7**  
M4 RACK, ZINC COATED, 22x22x1000 mm.  
PC/PACK 10



**ROA8**  
M4 RACK, 30x8x1000 mm, ZINC COATED WITH SPACERS AND SCREWS.  
PC/PACK 10



**ROA81**  
M6 RACK, 30x30x1000 mm, ZINC COATED.  
PC/PACK 1

FOR SWING GATES  
FOR SLIDING GATES  
BARRIER GATE OPERATOR SYSTEMS  
FOR GARAGE AND INDUSTRIAL DOORS  
CONTROL SYSTEMS AND ACCESSORIES  
COMPATIBILITY TABLE AND ALPHABETICAL INDEX



# BARRIER GATE OPERATOR SYSTEMS



NICEBAR SYSTEM

110 S-BAR  
112 M-BAR  
116 L-BAR

---

WIDE SYSTEM

120 S-WIDE  
M-WIDE  
L-WIDE

# S/M/L BAR BARRIER GATE OPERATORS FOR ALL SIZES

HIGH PERFORMING, RELIABLE AND DURABLE.  
ELEGANT, STREAMLINED DESIGN.  
CAREFULLY SELECTED MATERIALS.  
GREATER CONVENIENCE, SAFETY AT ALL TIMES.

## Integrated solutions for all requirements.

New range of barrier gate operators to control road access to car parks, industrial, private and block of flats transit areas, including high traffic ones.

## 5 models in 3 standard versions, up to 7 modular bars from 3 to 9 m.

Easy transport and optimised management in the warehouse.

NICE KEY RELEASE

TAMPER-PROOF  
FUNCTION: PROVISION FOR  
INTEGRATED ASSEMBLY OF  
PHOTOCELLS

PAINT-FINISHED ALUMINIUM  
FOR BAR SUPPORT  
AND COVER, WITH OPTIONAL  
FLASHING LIGHT

STEEL CASE WITH PROTECTIVE  
CATAPHORESIS TREATMENT  
AND PAINT FINISH, OR WITH  
STAINLESS STEEL CASE



# SELECTION GUIDE, COMPOSITION OF BARS AND ACCESSORIES

Bars and accessories are not included in the gear motor's code.

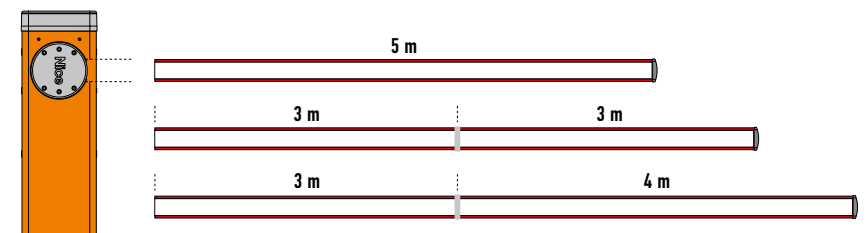
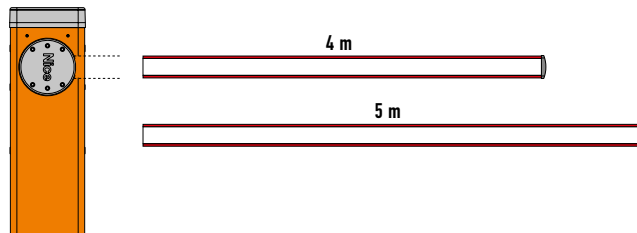
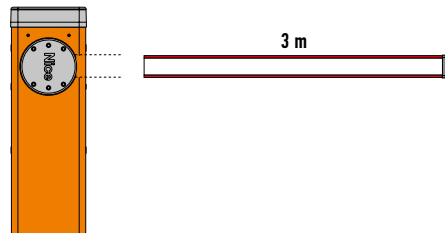
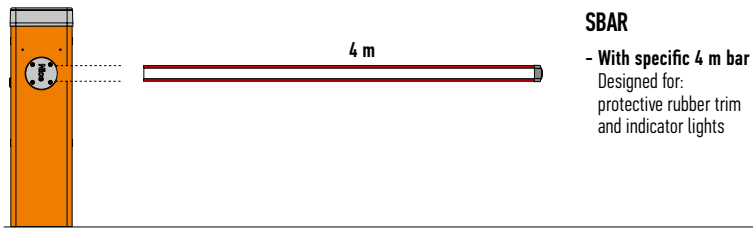

**M3BAR**  
 - With 3 m bar  
 Designed for:  
 protective rubber trim  
 and indicator lights

**M5BAR**  
 - With 4 m bar  
 Designed for:  
 protective rubber trim,  
 indicator lights,  
 rack (1 pc), mobile stand

- With 5 m bar  
 Designed for:  
 protective rubber trim  
 and indicator lights

**M7BAR**  
 - With 5 m bar  
 Designed for:  
 protective rubber trim,  
 indicator lights, rack (1 pc),  
 mobile stand

- With bar up to 6 m (3+3)\*  
 Designed for:  
 protective rubber trim,  
 indicator lights,  
 rack (2 pcs),  
 mobile stand

- With bar up to 7 m (3+4)\*  
 Designed for:  
 protective rubber trim  
 and indicator lights

\*Use XBA9 joint to assemble bars

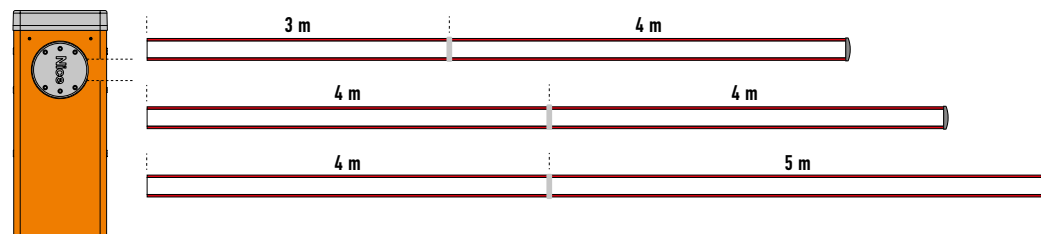

**LBAR**  
 - With bar of 7 m (3+4)\*  
 Designed for:  
 protective rubber trim,  
 indicator lights,  
 rack (2 pcs),  
 mobile stand

- With bar of 8 m (4+4)\*  
 Designed for:  
 protective rubber trim,  
 indicator lights,  
 rack (2 pcs),  
 mobile stand

- With bar of 9 m (4+5)\*  
 Designed for:  
 protective rubber trim  
 and indicator lights

\*Use XBA9 joint to assemble bars

FOR SWING GATES

FOR SLIDING GATES

BARRIER GATE  
OPERATOR SYSTEMS

FOR GARAGE  
AND INDUSTRIAL DOORS

CONTROL SYSTEMS  
AND ACCESSORIES

COMPATIBILITY TABLE  
AND ALPHABETICAL INDEX

# S-BAR

SOLEMYO OPERA BLUEBUS 24V

## Electromechanical road barrier system for control of road access.

24 Vdc gear motor with built-in control unit.

For bar up to 4 m.

**Strength and reliability:** robust structure in steel, new high strength balancing springs guaranteed up to 500,000 opening and closing operations and elliptical section bar with high wind-gust resistance.

Optional flashing or traffic light can be integrated in cover.



**More comfort and safety in programming and maintenance phases:** the separate enclosures for electronics and mechanics protect internal parts from potential risks.

**Rapid and easy access** to the control unit located in the upper section of the barrier body.

Simple fixture of the completely concealed photocells onto the specially designed seats on the barrier body.

**More safety and reliability:** obstacle detection and monitoring of motor absorption during automation movement.

Automatic fault diagnostics during operation with consequent signalling of fault type through specific flash sequences.

Provision for connection of latest generation optical and resistive sensitive edges (with 8.2 KOhm resistance).

**Energy saving:** the system sets to standby when not in use to save consumption.

**No blackouts:** emergency backup power with the optional batteries housed inside the case.

**Release from side with Nice triangular key,** can be installed on either side.

## IN ORDER TO HAVE A FULLY FUNCTIONAL BARRIER GATE OPERATOR SYSTEM:

1. CHOOSE THE GEAR MOTOR

2. SELECT THE BAR

3. COMPLETE THE SYSTEM WITH THE OPTIONAL ACCESSORIES

### WITH BAR UP TO 4 m, IRREVERSIBLE 230 Vac, 24 Vdc MOTOR, WITH FOUNDATION PLATE:

CODE	DESCRIPTION
SBAR	WITH STEEL CASE WITH PROTECTIVE CATAPHORESIS TREATMENT AND PAINT FINISH
SBARI	WITH STAINLESS STEEL CASE

### TECHNICAL SPECIFICATIONS

CODE	SBAR	SBARI
<b>ELECTRICAL DATA</b>		
POWER SUPPLY (Vac 50/60 Hz)		230
POWER SUPPLY (Vdc)		24
ABSORPTION (A)		1
POWER (W)		300
<b>PERFORMANCE DATA</b>		
SPEED (S)		<4
TORQUE (Nm)		100
WORK CYCLE (CYCLES/HOUR)		100
<b>DIMENSIONAL AND GENERAL DATA</b>		
PROTECTION LEVEL (IP)		44
WORKING TEMP. (°C MIN/MAX)		-20 ÷ +50
DIMENSIONS (mm)		330x180x1180 h
WEIGHT (kg)		46

### DIMENSIONS

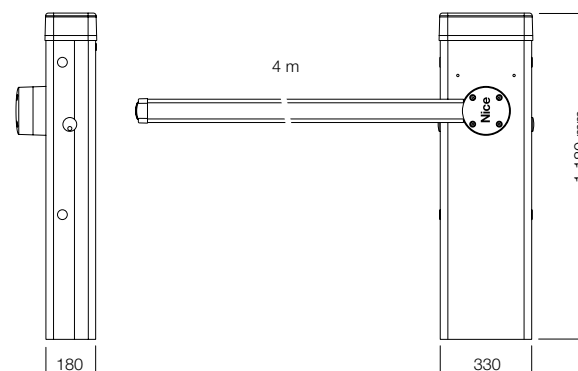

## INSTALLATION DIAGRAM

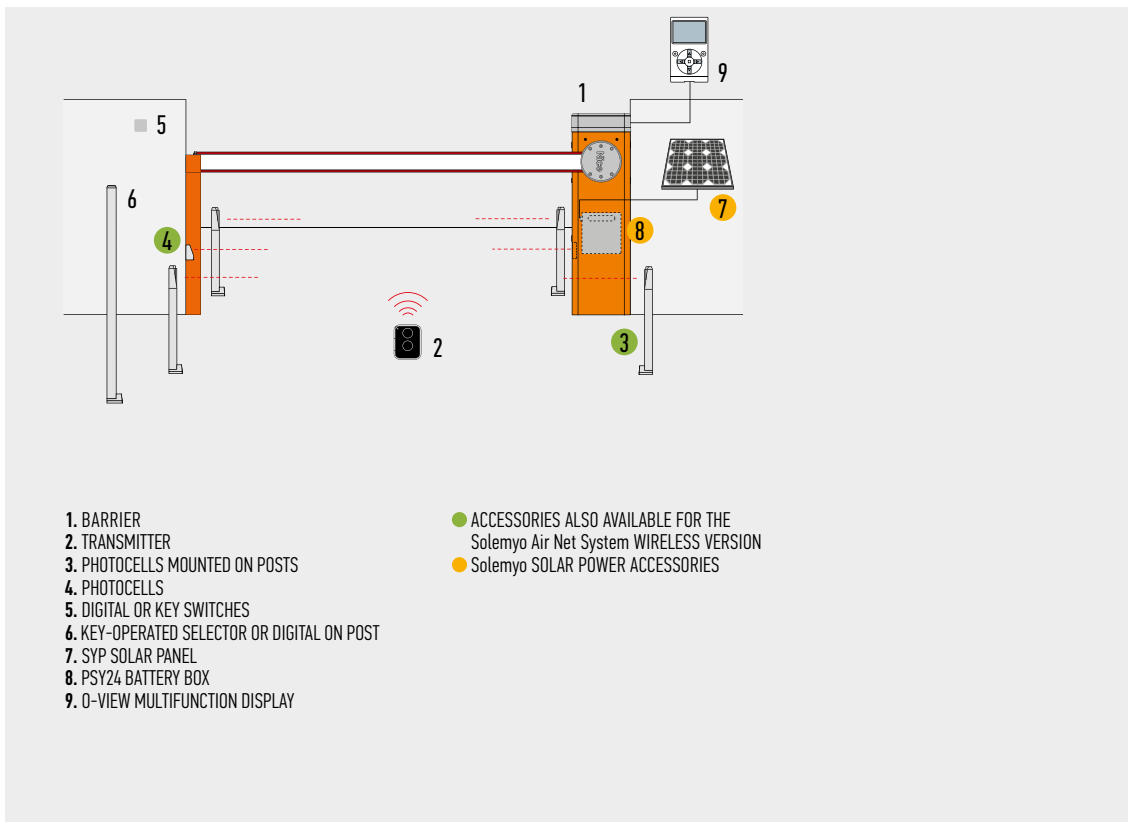

## COMPATIBILITY TABLE WITH CONTROL SYSTEMS AND ACCESSORIES

CODE	RECEIVER			TRANSMITTER			PHOTOCELLS						FLASHING LIGHT								
	Built-in*	FLOX12R*	OXI	ERA INTI	ERA ONE	ERA FLOR	NICEWAY	EPS	EPM	EPL	EPSB	EPMB	EPLB	F210	FT210	F210B	FT210B	EL	EL24	ELB	WLT
<b>SBAR / SBARI</b>			●	●	●	●	●				●	●	●			●	●			●	●

\*Radio receiver incompatible with Opera system

## BARS



**XBA19**  
 WHITE PAINT-FINISHED ALUMINIUM BAR  
 45x58x4000 mm.  
 PC/PACK 1



**WA10**  
 RED ADHESIVE REFLECTOR STRIPS.  
 PC/PACK 24



**WA11**  
 ADJUSTABLE STAND FOR BARS.  
 PC/PACK 1

## ACCESSORIES



**XBA20**  
 SPARE CONTROL UNIT FOR SBAR.  
 PC/PACK 1

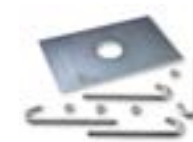

**SIA1**  
 ANCHORAGE BASE WITH CLAMPS.  
 PC/PACK 1



**KIT SOLEMYO**  
 THE SOLAR POWER TO AUTOMATE GATES, GARAGE DOORS OR BARRIER GATES.  
 SEE PAGE 200



**PS124**  
 24 V BATTERY WITH INTEGRATED BATTERY CHARGER.  
 PC/PACK 1



**XBA7**  
 INTEGRABLE FLASHING LIGHT.  
 PC/PACK 1



**XBA13**  
 RUBBER IMPACT PROTECTION STRIP. LENGTH 1 m.  
 PC/PACK 9



**XBA4**  
 INDICATOR LIGHTS FOR CLICK FIXTURE ON UPPER OR LOWER SIDE OF BAR. LENGTH 4 m.  
 PC/PACK 1

Nice recommends customers order products in pallets in order to facilitate storage and delivery, and ensure packs are uniform. The number of packs per single pallet has been specified for this reason. Approximate draft.

FOR SWING GATES

FOR SLIDING GATES

BARRIER GATE OPERATOR SYSTEMS

FOR GARAGE AND INDUSTRIAL DOORS

CONTROL SYSTEMS AND ACCESSORIES

COMPATIBILITY TABLE AND ALPHABETICAL INDEX

# M-BAR

SOLEMYO OPERA BLUEBUS 24V

## Electromechanical road barrier system for control of road access.

24 Vdc gear motor with built-in control unit and loop detector.

### For bars up from 3 to 7 m.

**Modular:** bars are easily assembled using the aluminium expansion joint.

Possibility for intelligent control of two opposing automations thanks to “master/slave” function.

**Strength and reliability:** robust structure in steel, new high strength balancing springs guaranteed up to 1,000,000 opening and closing operations and elliptical section bar with high wind-gust resistance.

Optional flashing or traffic light can be integrated in cover.  
Encoder movement control and electromechanical limit switches.  
**More comfort and safety in programming and maintenance phases:** the separate enclosures for electronics and mechanics protect internal parts from potential risks.

**Rapid and easy access** to the control unit located in the upper section of the barrier body.

Simple fixture of the completely concealed photocells onto the specially designed seats on the barrier body.

**More safety and reliability:** obstacle detection and monitoring of motor absorption during automation movement.

Automatic fault diagnostics during operation with consequent signalling of fault type through specific flash sequences.

Provision for connection of latest generation optical and resistive sensitive edges (with 8.2 KOhm resistance).

**Energy saving:** the system sets to standby when not in use to save consumption.

**No blackouts:** emergency backup power with the optional batteries housed inside the case.

**Release from side with metal key,** can be installed on either side.



## IN ORDER TO HAVE A FULLY FUNCTIONAL BARRIER GATE OPERATOR SYSTEM:

1. CHOOSE THE GEAR MOTOR

2. SELECT THE BAR

3. COMPLETE THE SYSTEM WITH THE OPTIONAL ACCESSORIES

### WITH BAR UP TO 3 m, IRREVERSIBLE 230 Vac, 24 Vdc MOTOR, WITH FOUNDATION PLATE:

CODE	DESCRIPTION
M3BAR	WITH STEEL CASE WITH PROTECTIVE CATAPHORESIS TREATMENT AND PAINT FINISH. FOR INTENSIVE USE
M3BARI	WITH STAINLESS STEEL CASE

### WITH BAR UP TO 4 OR 5 m, IRREVERSIBLE 230 Vac, 24 Vdc MOTOR, WITH FOUNDATION PLATE:

CODE	DESCRIPTION
M5BAR	WITH STEEL CASE WITH PROTECTIVE CATAPHORESIS TREATMENT AND PAINT FINISH. FOR INTENSIVE USE
M5BARI	WITH STAINLESS STEEL CASE

### WITH BAR UP TO 5, 6 OR 7 m, IRREVERSIBLE 230 Vac, 24 Vdc MOTOR, WITH FOUNDATION PLATE:

CODE	DESCRIPTION
M7BAR	WITH STEEL CASE WITH PROTECTIVE CATAPHORESIS TREATMENT AND PAINT FINISH
M7BARI	WITH STAINLESS STEEL CASE

## TECHNICAL SPECIFICATIONS

CODE	M3BAR	M3BARI	M5BAR	M5BARI	M7BAR	M7BARI
<b>ELECTRICAL DATA</b>						
POWER SUPPLY (Vac 50/60 Hz)				230		
POWER SUPPLY (Vdc)				24		
ABSORPTION (A)	1,3		1,1		1,1	
POWER (W)	150		110		110	
<b>PERFORMANCE DATA</b>						
SPEED MIN.=MAX. (S)	1,5 ÷ 4		3 ÷ 6		6 ÷ 10	
TORQUE (Nm)	100		200		300	
WORK CYCLE (CYCLES/HOUR)	600		450		200	
<b>DIMENSIONAL AND GENERAL DATA</b>						
PROTECTION LEVEL (IP)				54		
WORKING TEMP. (°C MIN/MAX)				-20 ÷ +55		
DIMENSIONS (mm)				400x299x1215 h		
WEIGHT (kg)				80		85

## DIMENSIONS

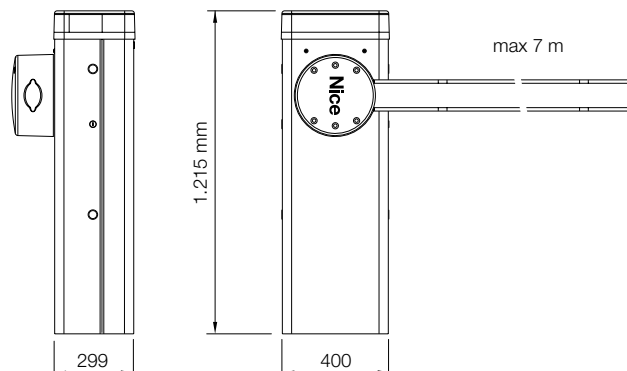



## INSTALLATION DIAGRAM

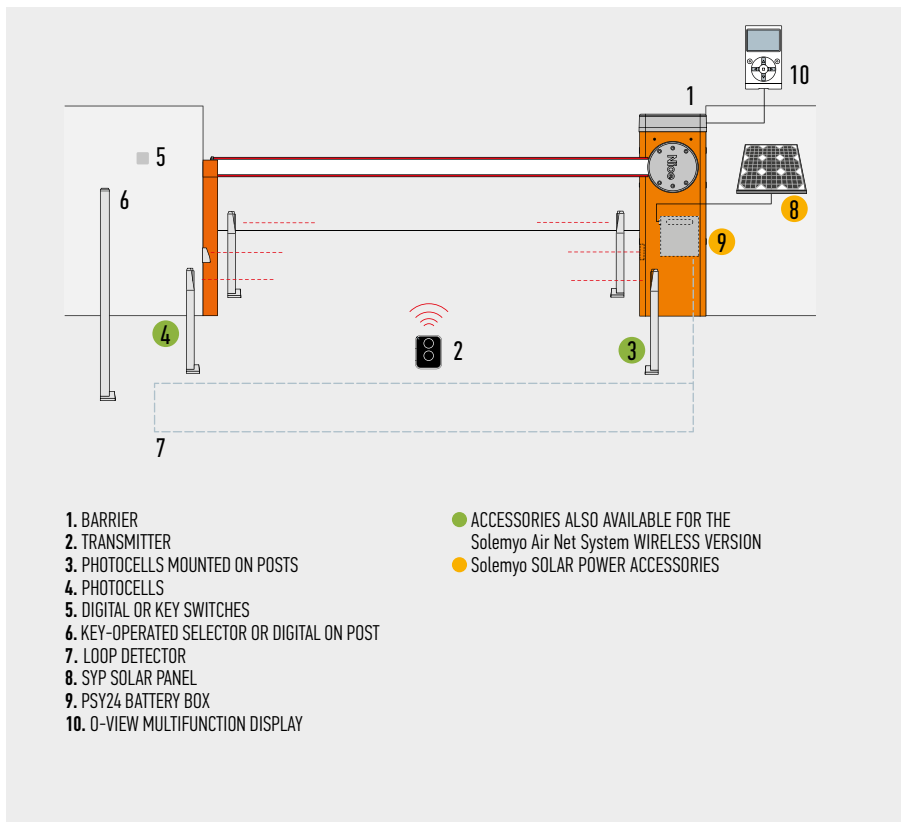

## COMPATIBILITY TABLE WITH CONTROL SYSTEMS AND ACCESSORIES

CODE	RECEIVER		TRANSMITTER				PHOTOCELLS							FLASHING LIGHT							
	Built-in*	FLOX2R*	OXI	ERA INTI	ERA ONE	ERA FLOR	NICEWAY	EPS	EPM	EPL	EPSB	EPMB	EPLB	F210	FT210	F210B	FT210B	EL	EL24	ELB	WLT
<b>M3BAR / M3BARI</b>			●								●	●	●			●	●			●	●
<b>M5BAR / M5BARI</b>			●	●	●	●	●				●	●	●			●	●			●	●
<b>M7BAR / M7BARI</b>			●	●	●	●	●				●	●	●			●	●			●	●

\*Radio receiver incompatible with Opera system

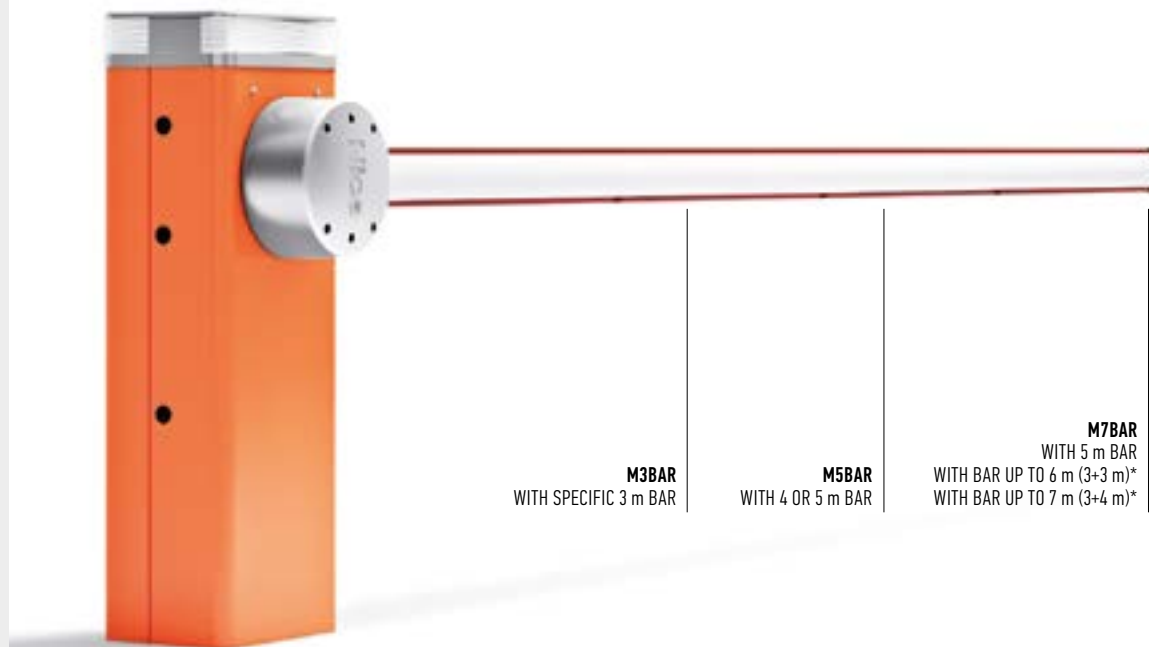

\*Use XBA9 joint to assemble bars



**KIT SOLEMYO**  
 THE SOLAR POWER TO  
 AUTOMATE GATES, GARAGE  
 DOORS OR BARRIER GATES.  
 SEE PAGE 200

Nice recommends customers order products in pallets in order to facilitate storage and delivery, and ensure packs are uniform. The number of packs per single pallet has been specified for this reason. Approximate draft.

FOR SWING GATES

FOR SLIDING GATES

BARRIER GATE  
 OPERATOR SYSTEMS

FOR GARAGE  
 AND INDUSTRIAL DOORS

CONTROL SYSTEMS  
 AND ACCESSORIES

COMPATIBILITY TABLE  
 AND ALPHABETICAL INDEX

# ACCESSORIES M-BAR

## ACCESSORIES FOR M3BAR, M5BAR, M7BAR



**XBA3HF**  
SPARE CONTROL UNIT.  
PC/PACK 1



**PS224**  
24 Vdc BUFFER BATTER.  
PC/PACK 1



**XBA13**  
RUBBER IMPACT PROTECTION  
STRIP. LENGTH 1 m.  
PC/PACK 9



**WA10**  
RED ADHESIVE  
REFLECTOR STRIPS.  
PC/PACK 24



**XBA8**  
INTEGRABLE TRAFFIC LIGHT.  
PC/PACK 1



**XBA7**  
INTEGRABLE FLASHING LIGHT.  
PC/PACK 1



**XBA16**  
ANCHORAGE BASE WITH  
CLAMPS, FOR MBAR.  
PC/PACK 1



**WA11**  
ADJUSTABLE STAND  
FOR BARS.  
PC/PACK 1

## BARS FOR M3BAR

## ACCESSORIES FOR M3BAR



**XBA15**  
WHITE PAINT-FINISHED  
ALUMINIUM BAR  
69x92x3150 mm.  
PC/PACK 1



**XBA4**  
INDICATOR LIGHTS FOR CLICK  
FIXTURE ON UPPER OR LOWER  
SIDE OF BAR. LENGTH 4 m.  
PC/PACK 1



**XBA10**  
PIVOT JOINT  
FOR BARS UP TO 4 m.  
PC/PACK 1



**XBA11**  
JOINT FOR BARS XBA15  
(FROM 1950 mm  
TO 2400 mm).  
PC/PACK 1

### BARS FOR M5BAR



**XBA14**  
WHITE PAINT-FINISHED  
ALUMINIUM BAR  
69x92x4150 mm  
PC/PACK 1



**XBA5**  
WHITE PAINT-FINISHED  
ALUMINIUM BAR  
69x92x5150 mm.  
PC/PACK 1

### ACCESSORIES FOR M5BAR



**XBA4**  
INDICATOR LIGHTS FOR CLICK  
FIXTURE ON UPPER OR LOWER  
SIDE OF BAR. LENGTH 4 m.  
PC/PACK 1



**XBA6**  
INDICATOR LIGHTS FOR CLICK  
FIXTURE ON UPPER OR LOWER  
SIDE OF BAR. LENGTH 6 m.  
PC/PACK 1



**XBA10**  
PIVOT JOINT  
FOR BARS UP TO 4 m.  
PC/PACK 1



**XBA11**  
JOINT FOR BARS XBA15 AND  
XBA14 (FROM 1950 mm  
TO 2400 mm).  
PC/PACK 1



**WA12**  
MOBILE STAND FOR BARS  
- *NEW FULLY REINFORCED  
VERSION.*  
PC/PACK 1



**WA13**  
ALUMINIUM RACK UP TO 2 m.  
PC/PACK 1

### BARS FOR M7BAR



**XBA15**  
WHITE PAINT-FINISHED  
ALUMINIUM BAR  
69x92x3150 mm.  
PC/PACK 1



**XBA14**  
WHITE PAINT-FINISHED  
ALUMINIUM BAR  
69x92x4150 mm  
PC/PACK 1



**XBA5**  
WHITE PAINT-FINISHED  
ALUMINIUM BAR  
69x92x5150 mm.  
PC/PACK 1



**XBA9**  
EXPANSION JOINT.  
PC/PACK 1



**XBA6**  
INDICATOR LIGHTS FOR CLICK  
FIXTURE ON UPPER OR LOWER  
SIDE OF BAR. LENGTH 6 m.  
PC/PACK 1



**XBA18**  
INDICATOR LIGHTS FOR CLICK  
FIXTURE ON UPPER OR LOWER  
SIDE OF BAR. LENGTH 8 m.  
PC/PACK 1



**WA12**  
MOBILE STAND FOR BARS  
- *NEW FULLY REINFORCED  
VERSION.*  
PC/PACK 1



**WA13**  
ALUMINIUM RACK UP TO 2 m.  
PC/PACK 1

### ACCESSORIES FOR M7BAR

# L-BAR

SOLEMYO OPERA BLUEBUS 24V

## Electromechanical road barrier system for control of road access.

24 Vdc gear motor with built-in control unit and loop detector.

## Powerful and fast, for bars from 7 to 9 m.

**Modular:** bars are easily assembled using the aluminium expansion joint.

Possibility for intelligent control of two opposing automations thanks to **"master/slave" function**.

**Strength and reliability:** robust structure in steel, new high strength balancing springs guaranteed up to 1,000,000 opening and closing operations and elliptical section bar with high wind-gust resistance.

Optional flashing or traffic light can be integrated in cover.

Encoder movement control and electromechanical limit switches.

**More comfort and safety in programming and maintenance phases:** the separate enclosures for electronics and mechanics protect internal parts from potential risks.

**Rapid and easy access** to the control unit located in the upper section of the barrier body.

Simple fixture of the completely concealed photocells onto the specially designed seats on the barrier body.

**More safety and reliability:** obstacle detection and monitoring of motor absorption during automation movement.

Automatic fault diagnostics during operation with consequent signalling of fault type through specific flash sequences.

Provision for connection of latest generation optical and resistive sensitive edges (with 8.2 KOhm resistance).

**Energy saving:** the system sets to standby when not in use to save consumption.

**No blackouts:** emergency backup power with the optional batteries housed inside the case.

**Release from side with metal key,** can be installed on either side.



## IN ORDER TO HAVE A FULLY FUNCTIONAL BARRIER GATE OPERATOR SYSTEM:

1. CHOOSE THE GEAR MOTOR

2. SELECT THE BAR

3. COMPLETE THE SYSTEM WITH THE OPTIONAL ACCESSORIES

## FOR BARS UP TO 9 m, IRREVERSIBLE 230 Vac, 24 Vdc MOTOR, WITH FOUNDATION PLATE:

CODE	DESCRIPTION
LBAR	WITH STEEL CASE WITH PROTECTIVE CATAPHORESIS TREATMENT AND PAINT FINISH
LBARI	WITH STAINLESS STEEL CASE

## TECHNICAL SPECIFICATIONS

CODE	LBAR	LBARI
<b>ELECTRICAL DATA</b>		
POWER SUPPLY (Vac 50/60 Hz)	230	
ABSORPTION (A)	1.3	
POWER (W)	160	
<b>PERFORMANCE DATA</b>		
SPEED MIN.÷MAX. (S)	8 ÷ 12	
TORQUE (Nm)	400	
WORK CYCLE (CYCLES/HOUR)	150	
<b>DIMENSIONAL AND GENERAL DATA</b>		
PROTECTION LEVEL (IP)	54	
WORKING TEMP. (°C MIN/MAX)	-20 ÷ +50	
DIMENSIONS (mm)	500x299x1215 h	
WEIGHT (kg)	98	

## DIMENSIONS

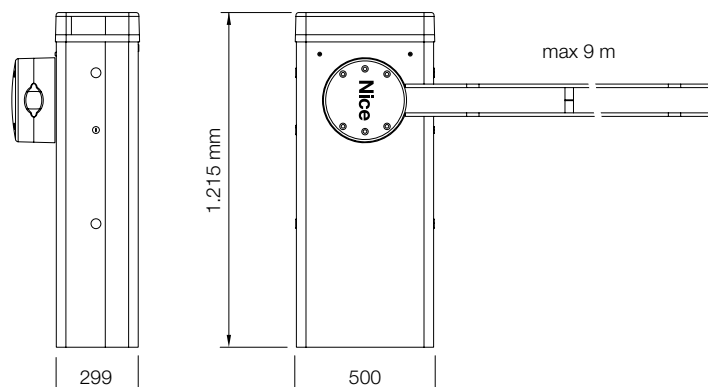

## INSTALLATION DIAGRAM

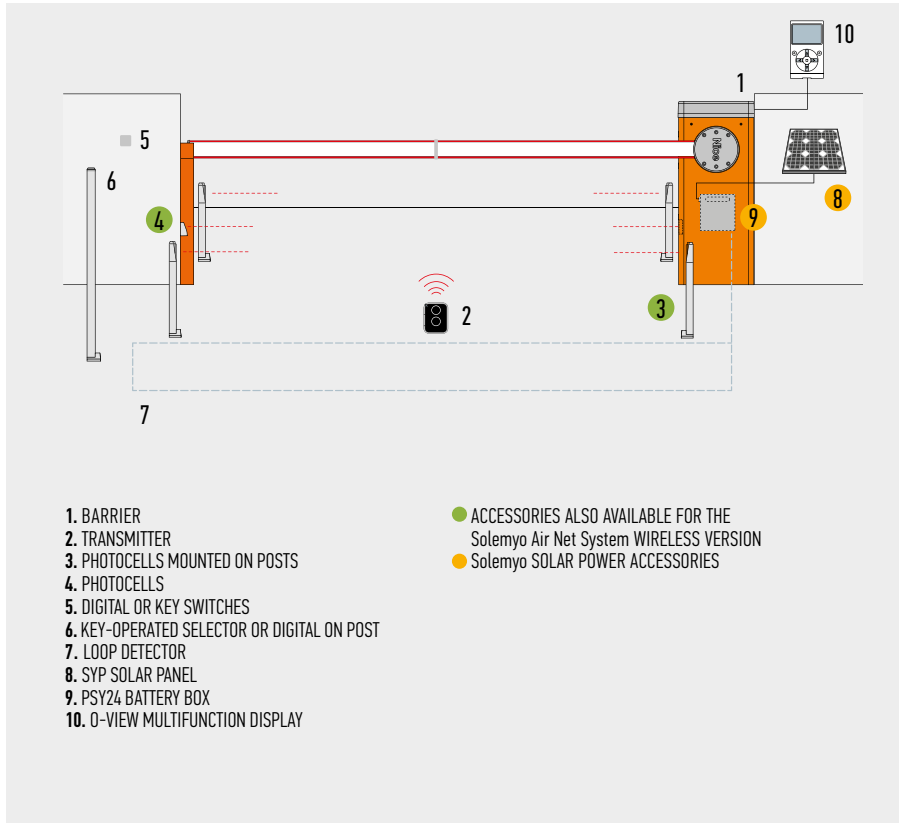

## COMPATIBILITY TABLE WITH CONTROL SYSTEMS AND ACCESSORIES

CODE	RECEIVER		TRANSMITTER				PHOTOCELLS							FLASHING LIGHT							
	Built-in*	FLOX2R*	OXI	ERA INTI	ERA ONE	ERA FLOR	NICEWAY	EPS	EPM	EPL	EPSB	EPMB	EPLB	F210	FT210	F210B	FT210B	EL	EL24	ELB	WLT
<b>LBAR / LBARI</b>			●	●	●	●	●				●	●	●			●	●			●	●

\*Radio receiver incompatible with Opera system

## BARS



**XBA15**  
 WHITE PAINT-FINISHED ALUMINIUM BAR  
 69x92x3150 mm.

PC/PACK 1



**XBA14**  
 WHITE PAINT-FINISHED ALUMINIUM BAR  
 69x92x4150 mm.

PC/PACK 1



**XBA5**  
 WHITE PAINT-FINISHED ALUMINIUM BAR  
 69x92x5150 mm.

PC/PACK 1



**XBA9**  
 EXPANSION JOINT.

PC/PACK 1



**XBA13**  
 RUBBER IMPACT PROTECTION STRIP. LENGTH 1 m.

PC/PACK 9



**WA10**  
 RED ADHESIVE REFLECTOR STRIPS.

PC/PACK 24



**XBA3HF**  
 SPARE CONTROL UNIT.

PC/PACK 1



**PS224**  
 24 Vdc BUFFER BATTERY.

PC/PACK 1



**XBA7**  
 INTEGRABLE FLASHING LIGHT.

PC/PACK 1



**WA13**  
 ALUMINIUM RACK UP TO 2 m.

PC/PACK 1



**XBA17**  
 ANCHORAGE BASE WITH CLAMPS, FOR LBAR.

PC/PACK 1



**WA12**  
 MOBILE STAND FOR BARS - NEW FULLY REINFORCED VERSION.

PC/PACK 1



**WA11**  
 ADJUSTABLE STAND FOR BARS.

PC/PACK 1

## ACCESSORIES

FOR SWING GATES

FOR SLIDING GATES

BARRIER GATE OPERATOR SYSTEMS

FOR GARAGE AND INDUSTRIAL DOORS

CONTROL SYSTEMS AND ACCESSORIES

COMPATIBILITY TABLE AND ALPHABETICAL INDEX

# NICE WIDE, SOLID AND ESSENTIAL



## EASY TO INSTALL

Large front door for quick and easy access.  
The bar can be assembled either on the right or left.  
Easily removable reinforced gear motor support.



## VANDAL-PROOF SAFETY

Photocells integrated inside the barrier body,  
minimum visual impact and maximum protection.



## PRACTICAL TO MAINTAIN

The built-in control unit can be removed to  
simplify wiring and maintenance. A backup  
battery installed inside the control unit  
prevents blackout problems.



## COMFORTABLE AND INTUITIVE RELEASE

Easy release of barrier system thanks to  
a triangular key.

REMOVABLE COVER FOR EASY  
ACCESS TO THE INSIDE PARTS

ELLIPTICAL SECTION BAR WITH  
HIGH WIND-GUST RESISTANCE

PROTECTED RELEASE  
AGAINST THE WEATHER

CATAPHORESIS TREATED  
AND PAINTED OR  
STAINLESS STEEL CASE

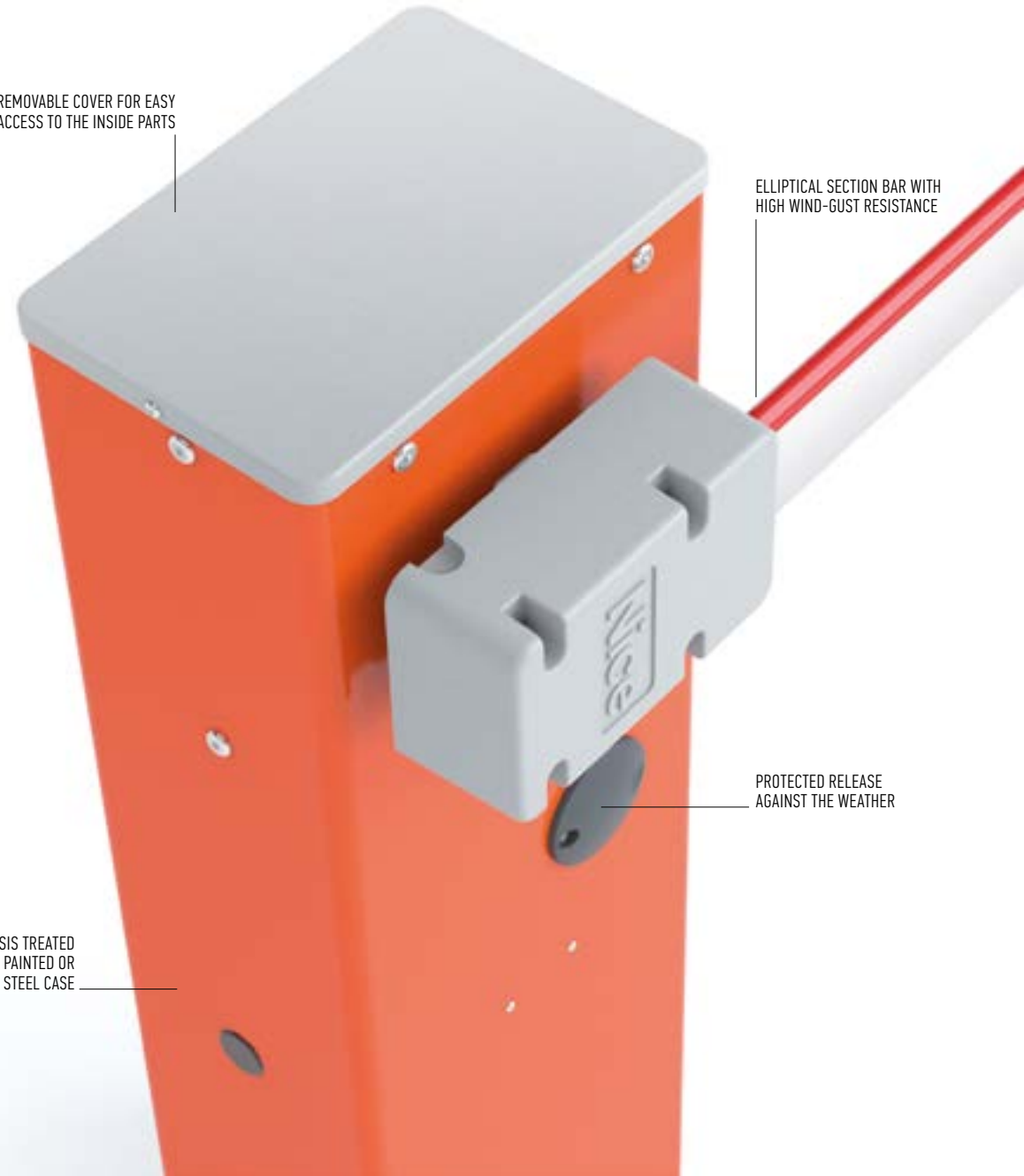

# SELECTION GUIDE, BARS AND ACCESSORIES

Bars and accessories are not included in the gear motor's code.

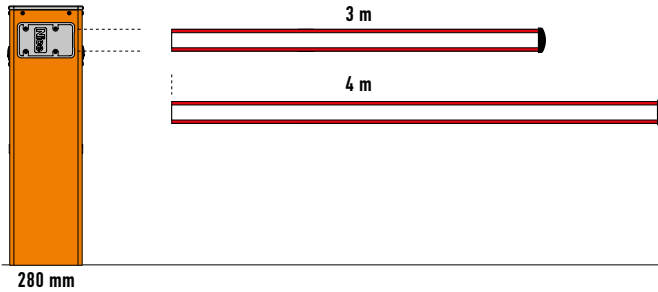

## WIDES

- With 3 m bar  
Can be fitted with:  
protective rubber trim,  
indicator lights,  
pivot joint,  
rack (1 pc)

- With 4 m bar  
Can be fitted with:  
protective rubber trim,  
indicator lights,  
pivot joint

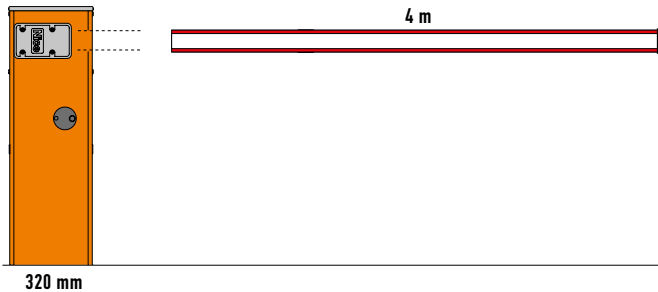

## WIDEM

- With 4 m bar  
Can be fitted with:  
protective rubber trim,  
indicator lights  
pivot joint,  
joint for bar, rack (2 pcs)  
mobile stand

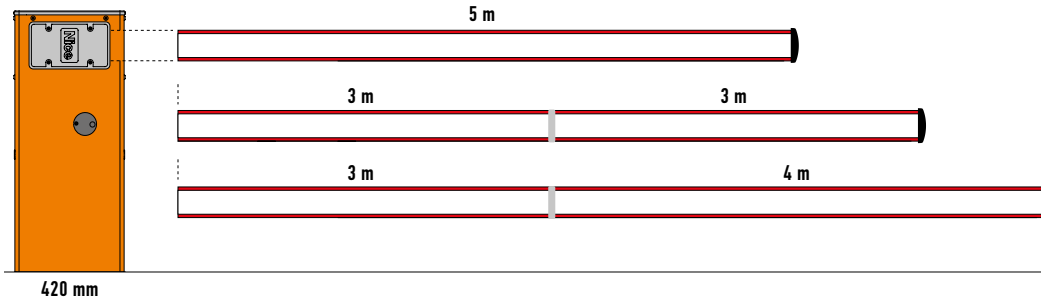

## WIDEL

- With 5 m bar  
Can be fitted with:  
protective rubber trim,  
indicator lights,  
rack (2 pcs),  
mobile stand

- With 6 m bar (3+3 m)\*  
Can be fitted with:  
protective rubber trim,  
indicator lights,  
rack (2 pcs),  
mobile stand

- With 7 m bar (3+4 m)\*  
Can be fitted with:  
protective rubber trim,  
indicator lights

\*Use the XBA9 joint to assemble bars

FOR SWING GATES

FOR SLIDING GATES

BARRIER GATE  
OPERATOR SYSTEMS

FOR GARAGE  
AND INDUSTRIAL DOORS

CONTROL SYSTEMS  
AND ACCESSORIES

COMPATIBILITY TABLE  
AND ALPHABETICAL INDEX

# WIDE SYSTEM

NEW

24V

## Electromechanical road barrier system for control of road access.

24 Vdc gear motor, with built-in control unit, adjustable speed and anti-crush safety function.

**Two types of case available**, galvanized steel or stainless steel (AISI 304) in **three sizes from 3 to 7 metres long**.

### More comfort and safety in programming and maintenance

The same built-in control unit is used on all versions, and is installed in the bottom part of the barrier body. Large front door for quick and easy access. Easily-removable reinforced gear motor support.

### Maximum anti-crush safety

when both opening and closing; barrier body supports on the inside for minimum visual impact.

**Electronically-adjustable speed** from 3.5" (Wide M) to 5" (Wide L) for fast opening.

### Sturdiness, reliability and easy installation

Elliptical section bar for lighter weight and higher wind-gust resistance; special profile for fast assembly of the accessories.

Optional pivot joint to protect the barrier in the event of collision.

The bar can be assembled either on the right or left.

**Easy to balance, thanks** to practical spring tension adjustment.

**No blackouts:** operation is guaranteed in the event of power outages by the PS234 backup battery installed inside the control unit.

**Release with triangular key** protected against the weather.



## IN ORDER TO HAVE A FULLY FUNCTIONAL BARRIER GATE OPERATOR SYSTEM:

1. CHOOSE THE GEAR MOTOR

2. SELECT THE BAR

3. COMPLETE THE SYSTEM WITH THE OPTIONAL ACCESSORIES

### WITH BAR UP TO 4 m, IRREVERSIBLE 230 Vac, 24 Vdc MOTOR, WITH FOUNDATION PLATE:

CODE	DESCRIPTION
<b>WIDES</b>	WITH PAINTED GALVANISED STEEL CASE
<b>WIDESI</b>	WITH STAINLESS STEEL CASE
<b>WIDEM</b>	WITH PAINTED GALVANISED STEEL CASE
<b>WIDEMI</b>	WITH STAINLESS STEEL CASE

### WITH BAR UP TO 7 m, IRREVERSIBLE 230 Vac, 24 Vdc MOTOR, WITH FOUNDATION PLATE:

CODE	DESCRIPTION
<b>WIDEL</b>	WITH PAINTED GALVANISED STEEL CASE
<b>WIDELI</b>	WITH STAINLESS STEEL CASE

## TECHNICAL SPECIFICATIONS

CODE	WIDES - WIDESI	WIDEM - WIDEMI	WIDEL - WIDELI
<b>ELECTRICAL DATA</b>			
POWER SUPPLY (Vac 50/60 Hz)	230		
ABSORPTION (A)	1	1.1	0.6
POWER (W)	300		360
<b>PERFORMANCE DATA</b>			
SPEED (S)	4	3.5	5
TORQUE (Nm)	100	140	200
WORK CYCLE (CYCLES/HOUR)	100	300	200
<b>DIMENSIONAL AND GENERAL DATA</b>			
PROTECTION LEVEL (IP)	44		
WORKING TEMP. (°C MIN/MAX)	-20 ÷ +50		
DIMENSIONS (mm)	280x178x1000 h	320x205x1000 h	420x205x1030 h
WEIGHT (kg)	40	46	54

## DIMENSIONS

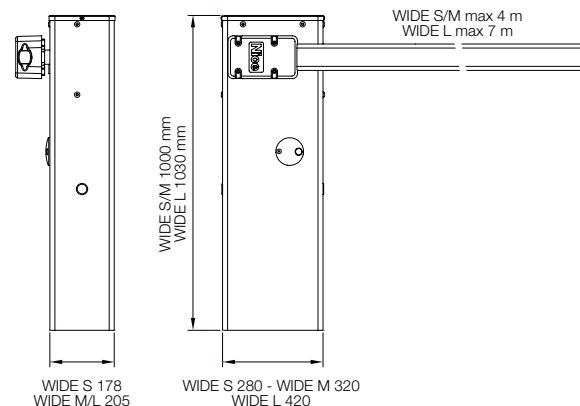



## INSTALLATION DIAGRAM

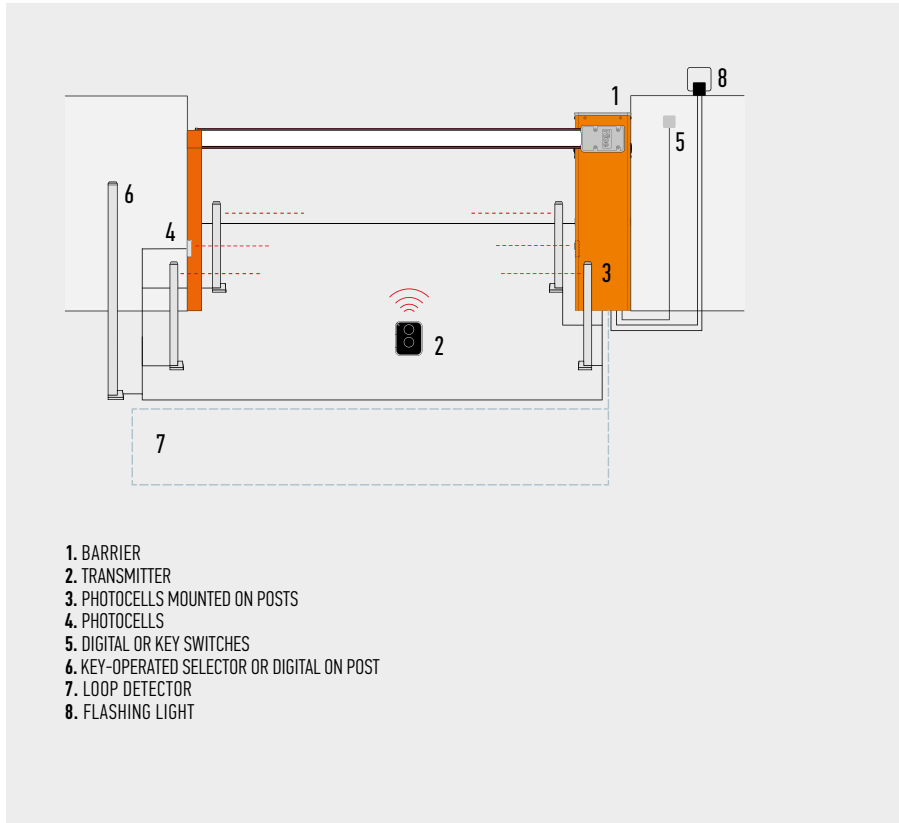

## COMPATIBILITY TABLE WITH CONTROL SYSTEMS AND ACCESSORIES

CODE	RECEIVER		TRANSMITTER						PHOTOCELLS							FLASHING LIGHT					
	Built-in*	FLOX2R*	OXI	ERA INTI	ERA ONE	ERA FLOR	NICEWAY	EPS	EPM	EPL	EPSB	EPMB	EPLB	F210	FT210	F210B	FT210B	EL	EL24	ELB	WLT
<b>WIDES - WIDESI</b>			●	●	●	●	●	●	●	●				●	●				●		
<b>WIDEM - WIDEMI</b>			●	●	●	●	●	●	●	●				●	●				●		
<b>WIDEL - WIDELI</b>			●	●	●	●	●	●	●	●				●	●				●		

\*Radio receiver incompatible with Opera system

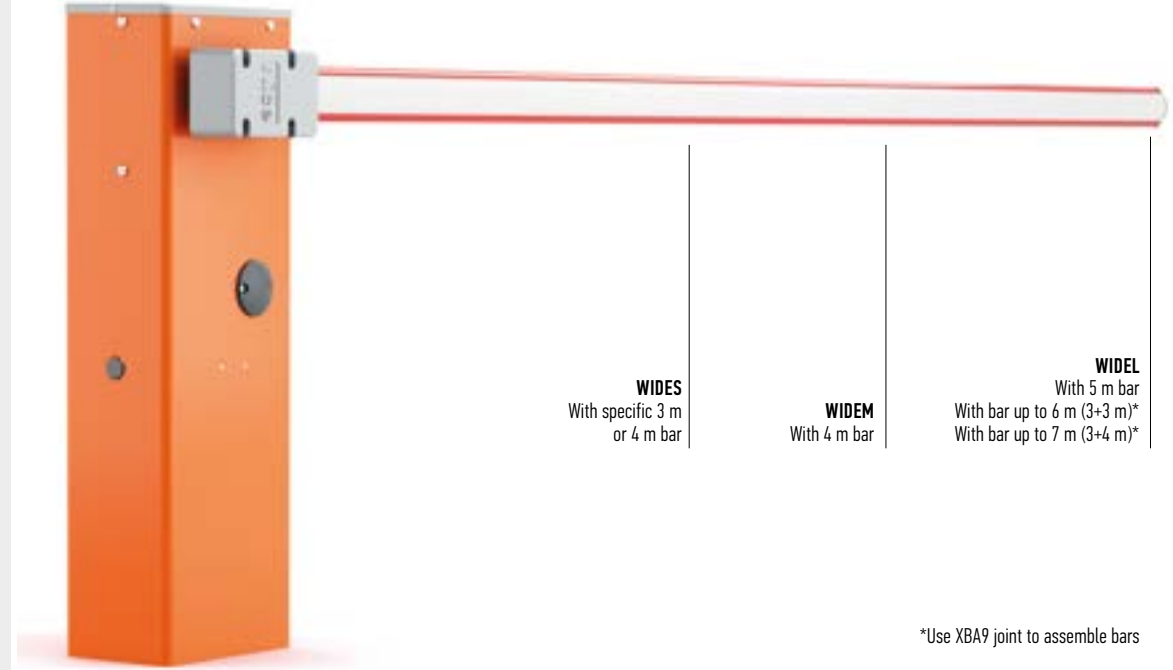

\*Use XBA9 joint to assemble bars

# ACCESSORIES WIDE

## COMMON ACCESSORIES

---



**WIA20**  
SPARE CONTROL UNIT.



**PS324**  
24 V BATTERY  
WITH INTEGRATED  
BATTERY CHARGER.  
PC/PACK 1



**XBA13**  
RUBBER IMPACT PROTECTION  
STRIP. LENGTH 1 m.  
PC/PACK 9



**WA10**  
RED ADHESIVE  
REFLECTOR STRIPS.  
PC/PACK 24



**WA11**  
ADJUSTABLE STAND  
FOR BARS.  
PC/PACK 1



**WA13**  
ALUMINIUM RACK UP TO 2 m.  
PC/PACK 1

## BARS FOR WIDE S

## ACCESSORIES FOR WIDE S

---



**XBA19**  
WHITE PAINT-FINISHED  
ALUMINIUM BAR  
45x58x4000 mm.  
PC/PACK 1



**XBA4**  
INDICATOR LIGHTS FOR CLICK  
FIXTURE ON UPPER OR LOWER  
SIDE OF BAR. LENGTH 4 m.  
PC/PACK 1



**WIA10**  
PIVOT JOINT.  
PC/PACK 1



**SIA1**  
ANCHORAGE BASE  
WITH CLAMPS.  
PC/PACK 1

## BARS FOR WIDE M



**XBA19**  
WHITE PAINT-FINISHED  
ALUMINIUM BAR  
45x58x4000 mm.  
PC/PACK 1

## ACCESSORIES FOR WIDE M



**XBA4**  
INDICATOR LIGHTS FOR CLICK  
FIXTURE ON UPPER OR LOWER  
SIDE OF BAR. LENGTH 4 m.  
PC/PACK 1



**WIA10**  
PIVOT JOINT.  
PC/PACK 1



**SIA1**  
ANCHORAGE BASE  
WITH CLAMPS.  
PC/PACK 1



**WA12**  
MOBILE STAND FOR BARS  
- *NEW FULLY REINFORCED  
VERSION.*  
PC/PACK 1



**WIA11**  
JOINT FOR BAR  
FOR WIDE M.  
PC/PACK 1

## BARS FOR WIDE L



**XBA15**  
WHITE PAINT-FINISHED  
ALUMINIUM BAR  
69x92x3150 mm.  
PC/PACK 1



**XBA14**  
WHITE PAINT-FINISHED  
ALUMINIUM BAR  
69x92x4150 mm  
PC/PACK 1



**XBA5**  
WHITE PAINT-FINISHED  
ALUMINIUM BAR  
69x92x5150 mm.  
PC/PACK 1



**XBA9**  
EXPANSION JOINT.  
PC/PACK 1



**XBA6**  
INDICATOR LIGHTS FOR CLICK  
FIXTURE ON UPPER OR LOWER  
SIDE OF BAR. LENGTH 6 m.  
PC/PACK 1



**XBA18**  
INDICATOR LIGHTS FOR CLICK  
FIXTURE ON UPPER OR LOWER  
SIDE OF BAR. LENGTH 8 m.  
PC/PACK 1

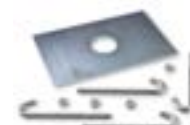

**SIA2**  
ANCHORAGE BASE  
WITH CLAMPS.  
PC/PACK 1



**WA12**  
MOBILE STAND FOR BARS  
- *NEW FULLY REINFORCED  
VERSION.*  
PC/PACK 1



# SYSTEMS FOR GARAGE AND INDUSTRIAL



FOR SECTIONAL AND UP-AND-OVER DOORS	128	SPINBUS
	132	SPINBUSKIT 20/21/22
	134	SPINBUSKIT 23
	136	SPINKIT

---

FOR UP-AND-OVER AND ARTICULATED DOORS	138	TEN
	140	TENKIT

---

FOR SECTIONAL DOORS	142	SOON
	144	SUMO

---

FOR FOLDING 2-LEAF DOORS	146	HYPP0 7100
--------------------------	-----	------------

---

FOR BALANCED ROLLING DOORS	150	GIRO
	152	RONDO

# SELECTION GUIDE

## FOR SECTIONAL AND UP-AND-OVER DOORS, ALSO AVAILABLE IN KIT

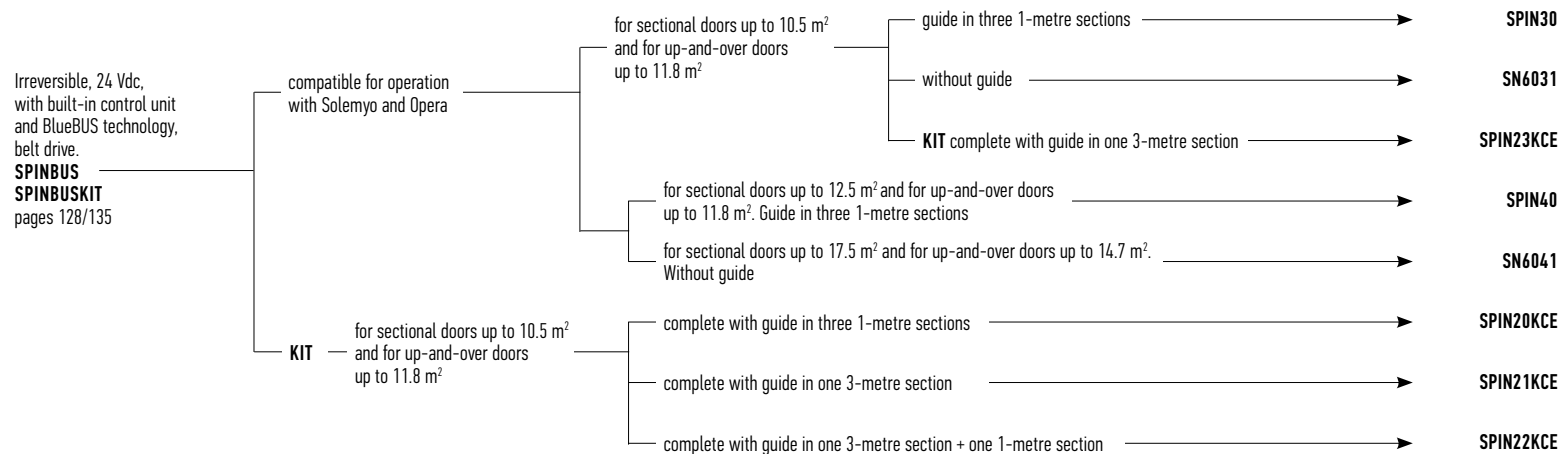

## FOR SECTIONAL AND UP-AND-OVER DOORS, IN KIT

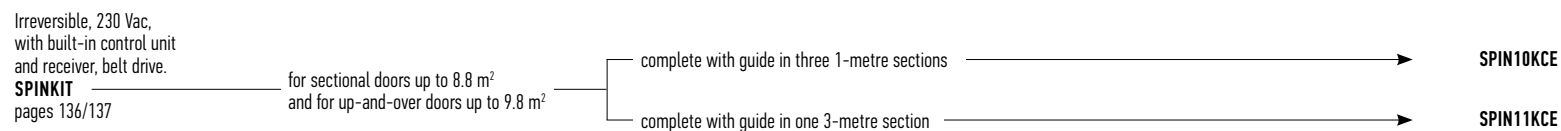

## FOR UP-AND-OVER DOORS, ALSO AVAILABLE IN KIT

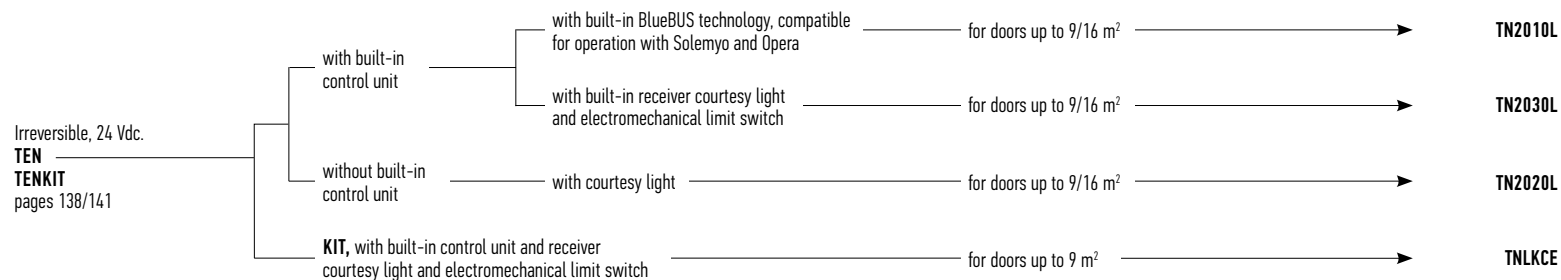

**FOR SECTIONAL DOORS, IDEAL FOR INDUSTRIAL AND COMMERCIAL USE**

Irreversible with built-in control unit  
24 Vdc motor, with absolute encoder  
and incorporated BlueBUS technology.  
Compatible for operation  
with Solemyo and Opera.

**SOON** → for doors up to 20 m<sup>2</sup> →

pages 142/143

**SO2000**



**FOR SECTIONAL AND SLIDING 2-LEAF DOORS FOR INDUSTRIAL AND COMMERCIAL USE**

Irreversible, 24 Vdc motor,  
with magnetic encoder,  
with no need for limit switch  
adjustment.

**SUMO** → IP44 →

- cruising speed, up to 35 m<sup>2</sup> → **SU2000**
- increased speed, up to 25 m<sup>2</sup> → **SU2000V**
- high speed, up to 15 m<sup>2</sup> → **SU2000VV**

→ IP54, up to 35 m<sup>2</sup> → **SU2010**

pages 144/145

**SU2000**

**SU2000V**

**SU2000VV**

**SU2010**



**FOR FOLDING 2-LEAF DOORS**

Irreversible  
with telescopic arm.

**HYPP0** →

- 230 Vac with limit switch on opening and closing → **HY7100**
- 24 Vdc version with magnetic encoder.  
Compatible with control units with BlueBUS technology,  
Solemyo and Opera → **HY7124**

pages 146/147

**HY7100**

**HY7124**



FOR SWING GATES

FOR SLIDING GATES

BARRIER GATE  
OPERATOR SYSTEMS

FOR GARAGE  
AND INDUSTRIAL DOORS

CONTROL SYSTEMS  
AND ACCESSORIES

ALPHABETICAL INDEX

# SPINBUS

SOLEMYO OPERA BLUEBUS 24V

**For sectional doors up to 12.5 m<sup>2</sup> and up-and-over garage doors up to 11.8 m<sup>2</sup>.** Irreversible electromechanical gear motor, for residential use, with belt drive, 24 Vdc motor, with magnetic encoder.

**Complete version of the guide in 3x1 m sections.**

**Rapid installation - anywhere!**

The adjustable head, cord-type release and cable-controlled, step-by-step release can be fitted in any part of the garage in order to actuate the system without a remote control device and without the need to install wall-mounted control units!

THREE-SECTION GUIDE IN GALVANISED STEEL WITH BELT DRIVE SYSTEM, VERY QUIET



BY ROTATING THE "PETAL" WHICH DIFFUSES THE LIGHT (40 W!), USERS ACCESS THE INCORPORATED BLUEBUS CONTROL UNIT

**Guaranteed savings and respect for the environment:**

with the connection to the mains in standby mode the control unit with radio connected consumes just 0.8 W (SPIN30) and 1.2 W (SPIN40); when connected to a battery or to the Solemyo kit, consumption in standby mode is reduced to 0.036 W.

**User-friendly thanks to the BlueBUS system:**

which enables connection by means of just two wires between the control unit and pair of photocells.

**Safe:** obstacle detection system and automatic programming of the working times; motor absorption is monitored during movement, self-diagnosis by means of a flashing light and courtesy light.

Acceleration and deceleration can be adjusted at the beginning and end of each opening and closing manoeuvre.

Can be connected with latest generation sensitive edges 8.2 KOhm.

**Luminous:** 40 W lamp that can be used as garage lightning.

CODE	DESCRIPTION	PACK/PALLET
SPIN30	IRREVERSIBLE, 230 Vac, 24 Vdc MOTOR, WITH INCORPORATED CONTROL UNIT, 800 N. COMPLETE WITH GUIDE IN THREE 1 m-SECTIONS	15
SPIN40	IRREVERSIBLE, 230 Vac, 24 Vdc MOTOR, WITH INCORPORATED CONTROL UNIT, 1000 N. COMPLETE WITH GUIDE IN THREE 1 m-SECTIONS	15

## TECHNICAL SPECIFICATIONS

CODE	SPIN30	SPIN40
<b>ELECTRICAL DATA</b>		
POWER SUPPLY (Vac 50/60 Hz)	230	
ABSORPTION (A)	1.3	1.4
POWER (W)	350	370
<b>PERFORMANCE DATA</b>		
SPEED (m/s)	0.20	
FORCE (N)	800	1000
WORK CYCLE (CYCLES/DAY)	50	
<b>DIMENSIONAL AND GENERAL DATA</b>		
PROTECTION LEVEL (IP)	40	
WORKING TEMP. (°C MIN/MAX)	-20 ÷ +50	
DIMENSIONS (mm)	311x327x105 h	
WEIGHT (kg)	3.6	4.7

## UTILISATION LIMITS

Using the maximum travel

	NON-PROJECTING UP-AND-OVER DOOR		PROJECTING UP-AND-OVER DOOR		SECTIONAL	
	H	L	H	L	H	L
SPIN30	2.2 m	4.2 m	2.8 m	4.2 m	2.4 m	5 m
SPIN40	2.2 m	4.2 m	2.8 m	4.2 m	2.4 m	5.2 m

## DIMENSIONS

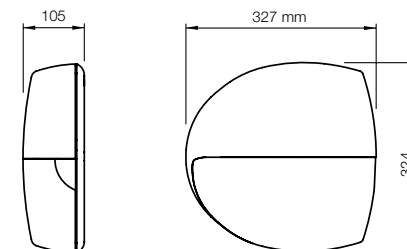



## INSTALLATION DIAGRAM

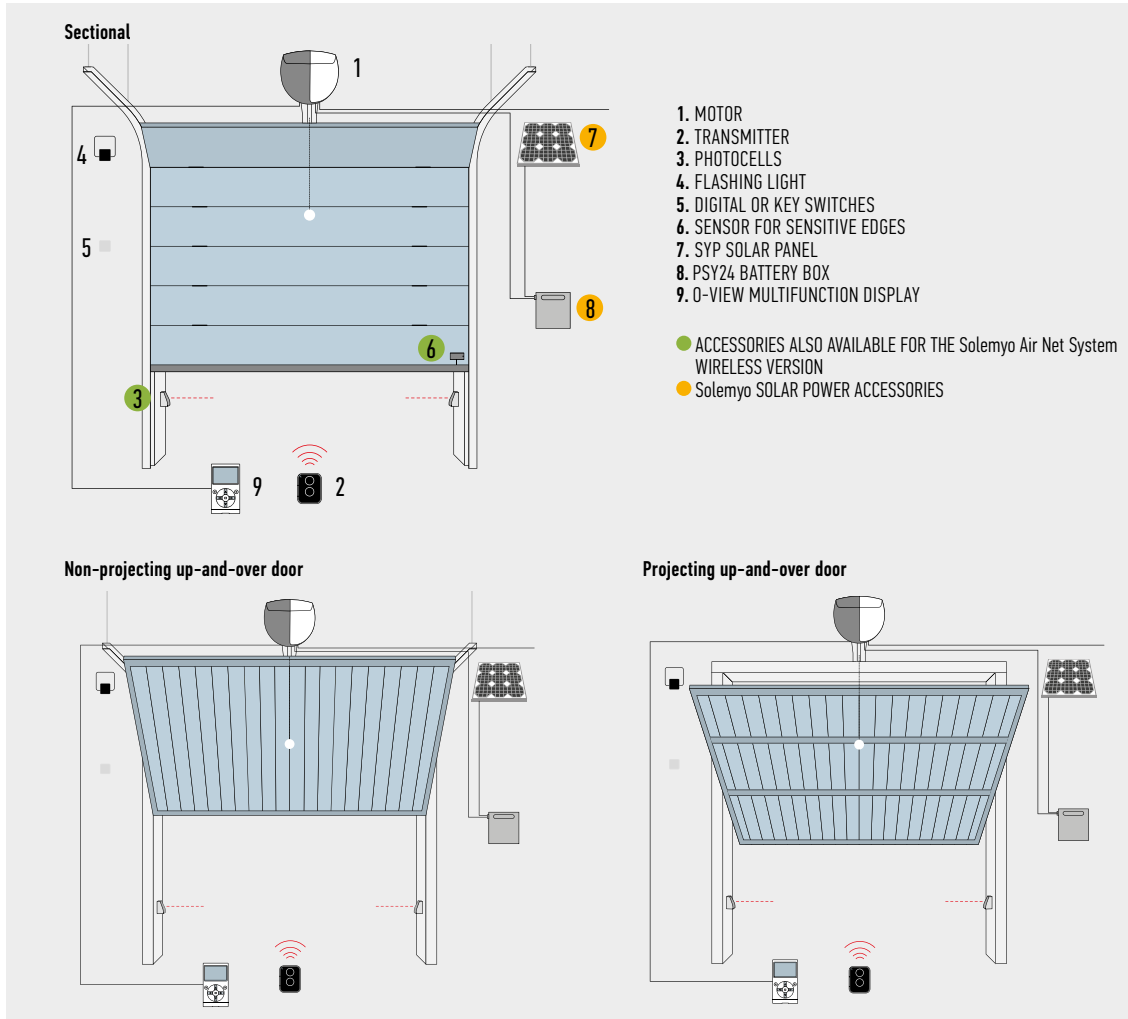

## COMPATIBILITY TABLE WITH CONTROL SYSTEMS AND ACCESSORIES

CODE	RECEIVER		TRANSMITTER				PHOTOCELLS								FLASHING LIGHT						
	Built-in*	FLOX/ZR*	DXI	ERA INTI	ERA ONE	ERA FLOR	NICEWAY	EPS	EPM	EPL	EPSB	EPMB	EPLB	FZ10	FTZ10	FZ10B	FTZ10B	EL	ELZ4	ELB	WLT
SPIN30			●	●	●	●	●				●	●	●			●	●			●	●
SPIN40			●	●	●	●	●				●	●	●			●	●			●	●

\*Radio receiver incompatible with Opera system

## ACCESSORIES

**SNA3**  
SPARE CONTROL UNIT FOR SPIN30/SN6031.

**SNA4**  
SPARE CONTROL UNIT FOR SPIN40/SN6041.

**PS124**  
24 V BATTERY WITH INTEGRATED BATTERY CHARGER.  
PC/PACK 1

**SPA2**  
KIT FOR UNLOCKING FROM THE OUTSIDE WITH CABLE.  
PC/PACK 1

**SPA5**  
OSCILLATING ARM SLIDING ON BEARINGS WITH OPTIMISED STRUCTURE FOR PROJECTING UP-AND-OVER DOORS.  
PC/PACK 1

**SPA6**  
LARGE 585 mm LONG CONNECTING ARM.  
PC/PACK 1

**SPA7**  
KIT OF TWO ADDITIONAL FIXING BRACKETS.  
PC/PACK 2

**SNA16**  
QUICK-CONNECT BRACKETS FOR CEILING MOUNTING.  
PC/PACK 10

**TS**  
SIGNBOARD.  
PC/PACK 1

**KIT SOLEMYO**  
THE SOLAR POWER TO AUTOMATE GATES, GARAGE DOORS OR BARRIER GATES. SEE PAGE 200

Nice recommends customers order products in pallets in order to facilitate storage and delivery, and ensure packs are uniform. The number of packs per single pallet has been specified for this reason. Approximate draft.

FOR SWING GATES

FOR SLIDING GATES

BARRIER GATE OPERATOR SYSTEMS

FOR GARAGE AND INDUSTRIAL DOORS

CONTROL SYSTEMS AND ACCESSORIES

COMPATIBILITY TABLE AND ALPHABETICAL INDEX

# SPINBUS

SOLEMYO OPERA BLUEBUS 24V

**For sectional doors up to 17.5 m<sup>2</sup> and up-and-over garage doors up to 14.7 m<sup>2</sup>.** 230 Vac irreversible electromechanical gear motor, for residential use, with belt drive, 24 Vdc motor, with magnetic encoder.

**To use with the SNA30 - SNA31 guides.**

**Rapid installation - anywhere!**

The adjustable head, cord-type release and cable-controlled, step-by-step release can be fitted in any part of the garage in order to actuate the system without a remote control device and without the need to install wall-mounted control units!

**Guaranteed savings and respect for the environment:** when connected to the mains on standby the control unit with radio connected consumes just 0.8 W (SN6031) and 1.2 W (SN6041); when connected to a battery or to the Solemyo kit, consumption in standby mode is reduced to 0.036 W.

**User-friendly thanks to the BlueBUS system:** which enables connection by means of just two wires between the control unit and pair of photocells.

**Safe:** obstacle detection system and automatic programming of the working times; motor absorption is monitored during movement, self-diagnosis by means of a flashing light and courtesy light. Acceleration and deceleration can be adjusted at the beginning and end of each opening and closing manoeuvre. Can be connected with latest generation sensitive edges 8.2 KOhm.

**Luminous:** 40 W lamp that can be used as garage lightning.



BY ROTATING THE "PETAL" WHICH DIFFUSES THE LIGHT USERS ACCESS THE INCORPORATED BLUEBUS CONTROL UNIT

CODE	DESCRIPTION	PACK/PALLET
<b>SN6031</b>	IRREVERSIBLE, 230 Vac, 24 Vdc MOTOR, WITH INCORPORATED CONTROL UNIT, 800 N	15
<b>SN6041</b>	IRREVERSIBLE, 230 Vac, 24 Vdc MOTOR, WITH INCORPORATED CONTROL UNIT, 1000 N	15

CODE	DESCRIPTION	PACK/PALLET
<b>SNA30</b>	PREASSEMBLED 3 m GUIDE	1
<b>SNA31</b>	1 m EXTENSION FOR GUIDE SNA30	1

## TECHNICAL SPECIFICATIONS

CODE	SN6031	SN6041
<b>ELECTRICAL DATA</b>		
POWER SUPPLY (Vac 50/60 Hz)	230	
ABSORPTION (A)	1.3	1.4
POWER (W)	350	370
<b>PERFORMANCE DATA</b>		
SPEED (m/s)	0.20	
FORCE (N)	800	1000
WORK CYCLE (CYCLES/DAY)	50	
<b>DIMENSIONAL AND GENERAL DATA</b>		
PROTECTION LEVEL (IP)	40	
WORKING TEMP. (°C MIN/MAX)	-20 ÷ +50	
DIMENSIONS (mm)	311x327x105 h	
WEIGHT (kg)	3.6	4.7

## UTILISATION LIMITS

Using the maximum travel

	NON-PROJECTING UP-AND-OVER DOOR		PROJECTING UP-AND-OVER DOOR		SECTIONAL	
	H	L	H	L	H	L
<b>SN6031 WITH SNA30</b>	2.2 m	4.2 m	2.8 m	4.2 m	2.4 m	5 m
<b>SN6041 WITH SNA30</b>	2.2 m	4.2 m	2.8 m	4.2 m	2.4 m	5.2 m
<b>SN6031 WITH SNA30 + SNA31</b>	3.2 m	2.9 m	3.5 m	3.4 m	3.4 m	3.5 m
<b>SN6041 WITH SNA30 + SNA31</b>	3.2 m	4.2 m	3.5 m	4.2 m	3.4 m	5.2 m

## DIMENSIONS

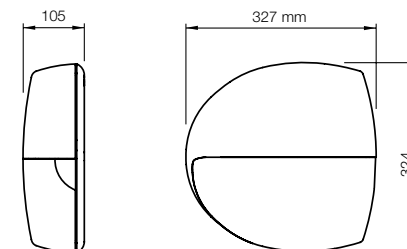

## INSTALLATION DIAGRAM

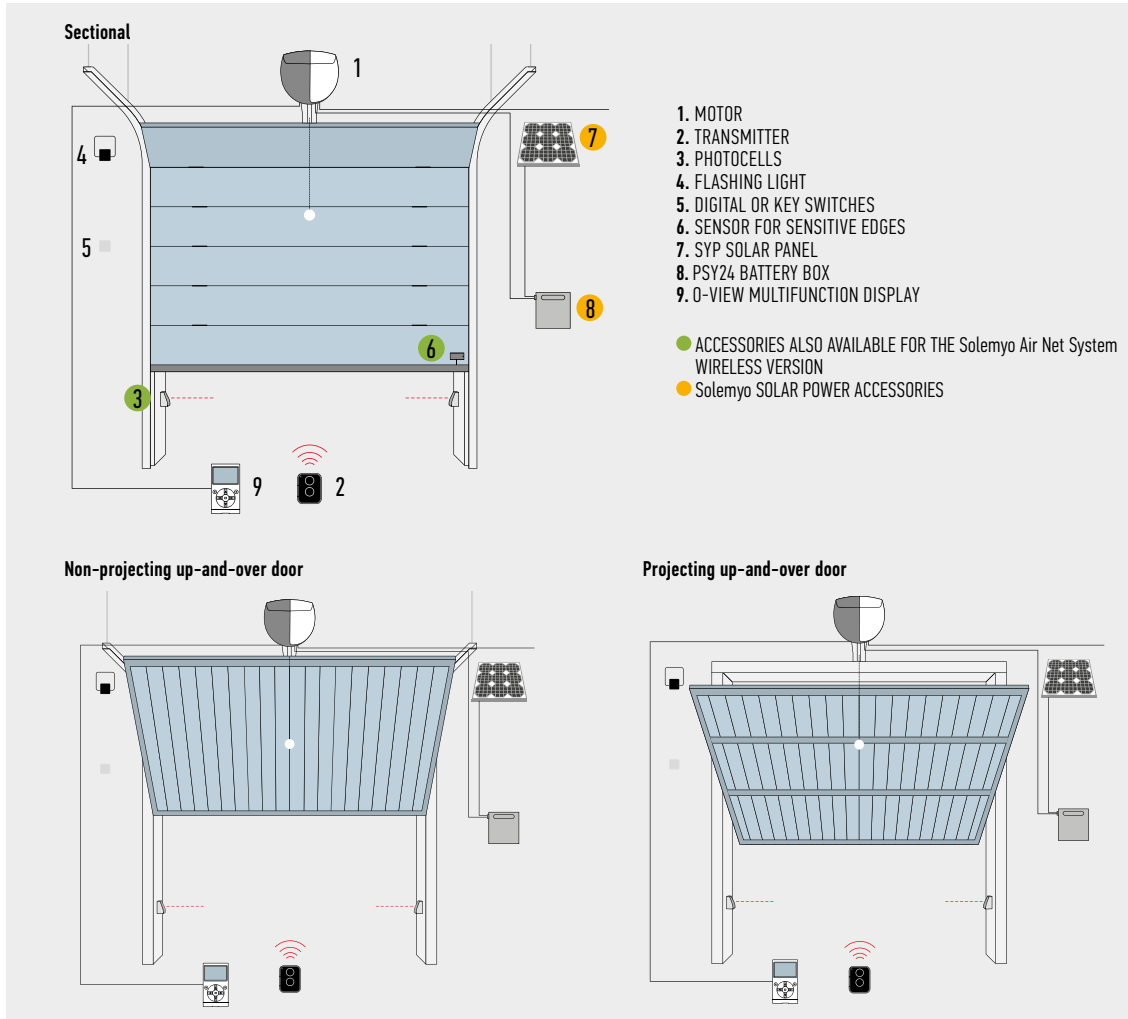

## COMPATIBILITY TABLE WITH CONTROL SYSTEMS AND ACCESSORIES

CODE	RECEIVER		TRANSMITTER				PHOTOCELLS								FLASHING LIGHT						
	Built-in*	FLOXIZR*	DXI	ERA INTI	ERA ONE	ERA FLOR	NICEWAY	EPS	EPM	EPL	EPSB	EPMB	EPLB	FZ10	FT210	FZ10B	FT210B	EL	EL24	ELB	WLT
SN6031			●	●	●	●	●				●	●	●			●	●			●	●
SN6041			●	●	●	●	●				●	●	●			●	●			●	●

\*Radio receiver incompatible with Opera system

## ACCESSORIES

**SNA3**  
SPARE CONTROL UNIT FOR SPIN30/SN6031.

**SNA4**  
SPARE CONTROL UNIT FOR SPIN40/SN6041.

**PS124**  
24 V BATTERY WITH INTEGRATED BATTERY CHARGER.  
PC/PACK 1

**SPA2**  
KIT FOR UNLOCKING FROM THE OUTSIDE WITH CABLE.  
PC/PACK 1

**SPA5**  
OSCILLATING ARM SLIDING ON BEARINGS WITH OPTIMISED STRUCTURE FOR PROJECTING UP-AND-OVER DOORS.  
PC/PACK 1

**SPA6**  
LARGE 585 mm LONG CONNECTING ARM.  
PC/PACK 1

**SPA7**  
KIT OF TWO ADDITIONAL FIXING BRACKETS.  
PC/PACK 2

**SNA16**  
QUICK-CONNECT BRACKETS FOR CEILING MOUNTING.  
PC/PACK 10

**KIT SOLEMYO**  
THE SOLAR POWER TO AUTOMATE GATES, GARAGE DOORS OR BARRIER GATES. SEE PAGE 200

**TS**  
SIGNBOARD.  
PC/PACK 1

FOR SWING GATES

FOR SLIDING GATES

BARRIER GATE OPERATOR SYSTEMS

FOR GARAGE AND INDUSTRIAL DOORS

CONTROL SYSTEMS AND ACCESSORIES

COMPATIBILITY TABLE AND ALPHABETICAL INDEX

# SPINBUSKIT 20/21/22

BLUEBUS 24V

For sectional doors up to 10.5 m<sup>2</sup>  
and up-and-over garage doors up to 11.8 m<sup>2</sup>.

### Three versions in kit:

- pre-mounted, **guide in three 1-metre sections** SPIN20KCE,
- **with pre-mounted guide of 3 m** SPIN21KCE or **pre-mounted**
- **guide of 4 m (3+1 m)** SPIN22KCE.

### Rapid installation - anywhere!

The adjustable head, cord-type release and cable-controlled, step-by-step release can be fitted in any part of the garage in order to actuate the system without a remote control device and without the need to install wall-mounted control units!

### User-friendly thanks to the BlueBUS system:

which enables connection by means of just two wires between the control unit and pair of photocells.

**Safe:** obstacle detection system and automatic programming of the working times; motor absorption is monitored during movement, self-diagnosis by means of a flashing light and courtesy light.

Acceleration and deceleration can be adjusted at the beginning and end of each opening and closing manoeuvre.

Can be connected with last generation sensitive edges 8.2 KOhm.

Courtesy light: 21 W lamp.

CODE	DESCRIPTION	PACK/PALLET
SPIN20KCE	KIT FOR AUTOMATING SECTIONAL AND UP-AND-OVER DOORS. GUIDE IN THREE 1-METRE SECTIONS	14
SPIN21KCE	KIT FOR AUTOMATING SECTIONAL AND UP-AND-OVER DOORS. PRE-MOUNTED GUIDE OF 3 m	15
SPIN22KCE	KIT FOR AUTOMATING SECTIONAL AND UP-AND-OVER DOORS. GUIDE IN ONE 3-METRE SECTION + ONE 1-METRE SECTION	15

**N.B.** The content of the package may vary: consult the retailer.

### TECHNICAL SPECIFICATIONS

CODE	SN6021
<b>ELECTRICAL DATA</b>	
POWER SUPPLY (Vac 50/60 Hz)	230
ABSORPTION (A)	0.8
POWER (W)	250
<b>PERFORMANCE DATA</b>	
SPEED (m/s)	0.20
FORCE (N)	650
WORK CYCLE (CYCLES/DAY)	50
<b>DIMENSIONAL AND GENERAL DATA</b>	
PROTECTION LEVEL (IP)	40
WORKING TEMP. (°C MIN/MAX)	-20 ÷ +50
DIMENSIONS (mm)	311x327x105 h
WEIGHT (kg)	3.6

### UTILISATION LIMITS

Using the maximum travel

	NON-PROJECTING UP-AND-OVER DOOR		PROJECTING UP-AND-OVER DOOR		SECTIONAL	
	H	L	H	L	H	L
SPIN20KCE	2.2 m	4.2 m	2.8 m	4.2 m	2.4 m	4.4 m
SPIN21KCE	2.2 m	4.2 m	2.8 m	4.2 m	2.4 m	4.4 m
SPIN22KCE	3.2 m	2.9 m	3.5 m	3.4 m	3.4 m	3.1 m

### DIMENSIONS

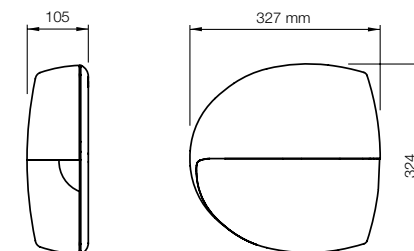

### THE KIT CONTAINS:

**SN6021**  
1 GEAR MOTOR WITH BUILT-IN SNA2 CONTROL UNIT AND SMXI PLUG-IN RECEIVER.



**FLO2RE**  
1 TRANSMITTER  
433.92 MHz, 2 CHANNELS.



**SPIN20KCE**  
GUIDE  
IN THREE 1-METRE SECTIONS.

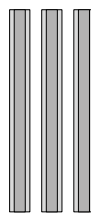

3 x 1 m

**SPIN21KCE**  
GUIDE  
IN ONE 3-METRE SECTION.



1 x 3 m

**SPIN22KCE**  
GUIDE  
IN ONE 3-METRE SECTION.  
+ ONE 1-METRE SECTION.

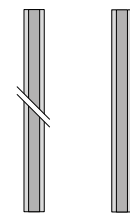

1 x 3 m 1 x 1 m

## INSTALLATION DIAGRAM

Sectional

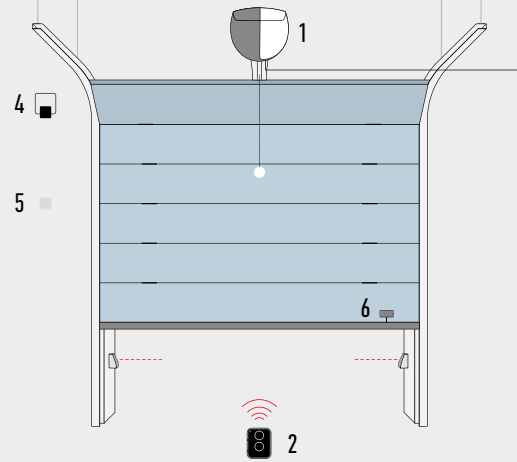

1. MOTOR
2. TRANSMITTER
3. PHOTOCELLS
4. FLASHING LIGHT
5. DIGITAL OR KEY SWITCHES
6. SENSOR FOR SENSITIVE EDGES

Non-projecting up-and-over door

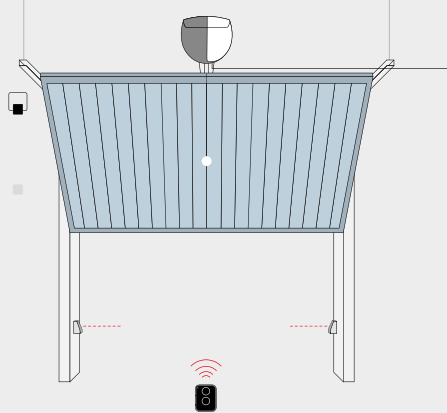

Projecting up-and-over door

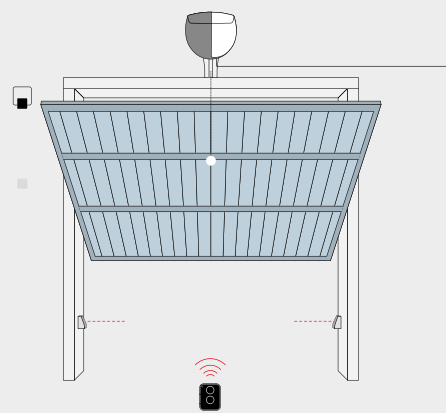

## ACCESSORIES



**SNA2**  
SPARE CONTROL UNIT  
FOR SPIN20KCE, SPIN21KCE  
AND SPIN22KCE.



**SPA2**  
KIT FOR UNLOCKING FROM  
THE OUTSIDE WITH CABLE.  
PC/PACK 1



**SPA5**  
OSCILLATING ARM SLIDING  
ON BEARINGS WITH  
OPTIMISED STRUCTURE  
FOR PROJECTING  
UP-AND-OVER DOORS.  
PC/PACK 1



**SPA6**  
LARGE 585 mm LONG  
CONNECTING ARM.  
PC/PACK 1



**SPA7**  
KIT OF TWO ADDITIONAL  
FIXING BRACKETS.  
PC/PACK 2



**SNA16**  
QUICK-CONNECT BRACKETS  
FOR CEILING MOUNTING.  
PC/PACK 10



**TS**  
SIGNBOARD.  
PC/PACK 1

Nice recommends customers order products in pallets in order to facilitate storage and delivery, and ensure packs are uniform. The number of packs per single pallet has been specified for this reason. Approximate draft.

FOR SWING GATES

FOR SLIDING GATES

BARRIER GATE  
OPERATOR SYSTEMS

FOR GARAGE  
AND INDUSTRIAL DOORS

CONTROL SYSTEMS  
AND ACCESSORIES

COMPATIBILITY TABLE  
AND ALPHABETICAL INDEX

# SPINBUSKIT 23

SOLEMYO OPERA BLUEBUS 24V

For sectional doors up to 10.5 m<sup>2</sup>  
and up-and-over garage doors up to 11.8 m<sup>2</sup>.

With pre-mounted 3-metre guide.

Rapid installation - anywhere!

The adjustable head, cord-type release and cable-controlled, step-by-step release can be fitted in any part of the garage in order to actuate the system without a remote control device and without the need to install wall-mounted control units!

**Guaranteed savings and respect for the environment:** with connection to the mains in standby mode the control unit with radio connected consumes just 5.2 W; when connected to a battery or to the Solemyo kit, consumption on standby is reduced to 0.036 W.

**Safe:** obstacle detection system and automatic programming of the working times; motor absorption is monitored during movement, self-diagnosis by means of a flashing light and courtesy light. Acceleration and deceleration can be adjusted at the beginning and end of each opening and closing manoeuvre. Can be connected with last generation sensitive edges 8.2 KOhm.

**Courtesy light:** 21 W lamp.

**No black out:** operation in the event of a power failure with optional batteries (PS124) housed inside the motor.

CODE	DESCRIPTION	PACK/PALLET
SPIN23KCE	KIT FOR AUTOMATING SECTIONAL AND UP-AND-OVER DOORS. PRE-MOUNTED GUIDE IN ONE 3-METRE SECTION	15

**N.B.** The content of the package may vary; consult the retailer.

## TECHNICAL SPECIFICATIONS

CODE	SN6021
<b>ELECTRICAL DATA</b>	
POWER SUPPLY (Vac 50/60 Hz)	230
ABSORPTION (A)	0.8
POWER (W)	250
<b>PERFORMANCE DATA</b>	
SPEED (m/s)	0.20
FORCE (N)	650
WORK CYCLE (CYCLES/DAY)	50
<b>DIMENSIONAL AND GENERAL DATA</b>	
PROTECTION LEVEL (IP)	40
WORKING TEMP. (°C MIN/MAX)	-20 ÷ +50
DIMENSIONS (mm)	311x327x105 h
WEIGHT (kg)	3.6

## UTILISATION LIMITS

Using the maximum travel

	NON-PROJECTING UP-AND-OVER DOOR		PROJECTING UP-AND-OVER DOOR		SECTIONAL	
	H	L	H	L	H	L
SPIN23KCE	2.2 m	4.2 m	2.8 m	4.2 m	2.4 m	4.4 m

## DIMENSIONS

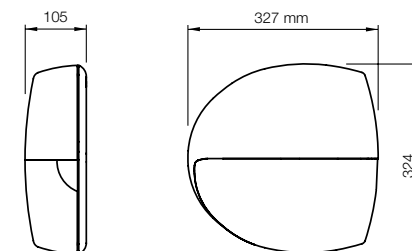

## THE KIT CONTAINS:

**SN6021**  
1 GEAR MOTOR WITH BUILT-IN CONTROL UNIT AND SMXI PLUG-IN RECEIVER.



**FLO2RE**  
1 TRANSMITTER  
433.92 MHz, 2 CHANNELS.



**SNA30**  
GUIDE  
IN ONE 3-METRE SECTION.

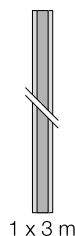

1 x 3 m

## INSTALLATION DIAGRAM

Nice recommends customers order products in pallets in order to facilitate storage and delivery, and ensure packs are uniform. The number of packs per single pallet has been specified for this reason. Approximate draft.

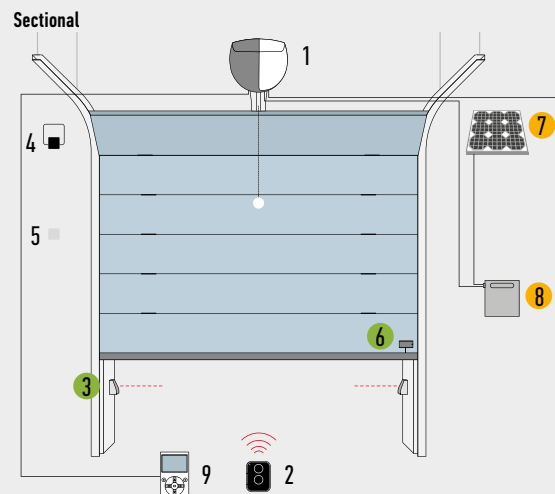

1. MOTOR
2. TRANSMITTER
3. PHOTOCELLS
4. FLASHING LIGHT
5. DIGITAL OR KEY SWITCHES
6. SENSOR FOR SENSITIVE EDGES
7. SYP SOLAR PANEL
8. PSY24 BATTERY BOX
9. 0-VIEW MULTIFUNCTION DISPLAY

- ACCESSORIES ALSO AVAILABLE FOR THE Solemyo Air Net System WIRELESS VERSION
- Solemyo SOLAR POWER ACCESSORIES

Non-projecting up-and-over door

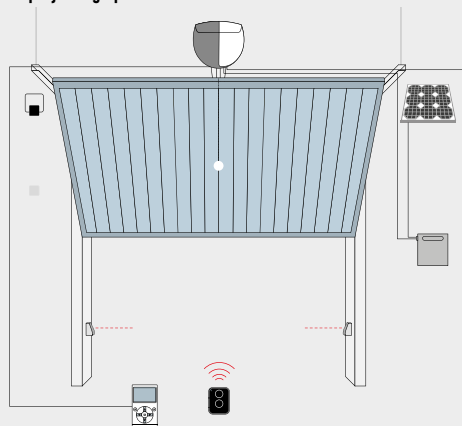

Projecting up-and-over door

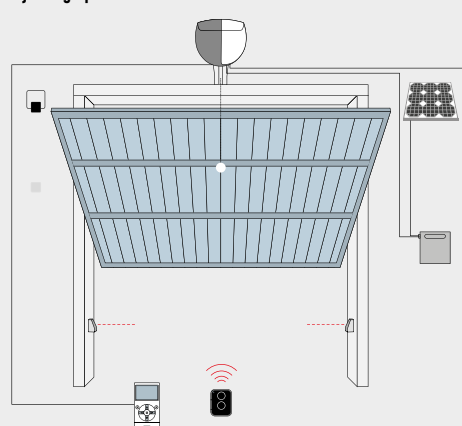

## ACCESSORIES



**SNA20**  
SPARE CONTROL UNIT  
FOR SPIN23KCE.



**PS124**  
24 V BATTERY  
WITH INTEGRATED  
BATTERY CHARGER.  
PC/PACK 1



**SPA2**  
KIT FOR UNLOCKING FROM  
THE OUTSIDE WITH CABLE.  
PC/PACK 1



**SPA5**  
OSCILLATING ARM SLIDING  
ON BEARINGS WITH OPTIMISED  
STRUCTURE FOR PROJECTING  
UP-AND-OVER DOORS.  
PC/PACK 1



**SPA6**  
LARGE 585 mm LONG  
CONNECTING ARM.  
PC/PACK 1



**SPA7**  
KIT OF TWO ADDITIONAL  
FIXING BRACKETS.  
PC/PACK 2



**SNA16**  
QUICK-CONNECT BRACKETS  
FOR CEILING MOUNTING.  
PC/PACK 10



**TS**  
SIGNBOARD.  
PC/PACK 1



**KIT SOLEMYO**  
THE SOLAR POWER TO  
AUTOMATE GATES, GARAGE  
DOORS OR BARRIER GATES.  
SEE PAGE 200

FOR SWING GATES

FOR SLIDING GATES

BARRIER GATE  
OPERATOR SYSTEMS

FOR GARAGE  
AND INDUSTRIAL DOORS

CONTROL SYSTEMS  
AND ACCESSORIES

ALPHABETICAL INDEX

# SPINKIT

24V

**For sectional doors up to 8.8 m<sup>2</sup> and up-and-over garage doors up to 9.8 m<sup>2</sup>, belt drive.**

**Two versions in kit:**

- pre-assembled, **3x1 m sections guide** (SPIN10KCE)
- **pre-assembled 3 m guide** (SPIN11KCE).

**Advanced:** incorporated radio card, compatible with the Nice Flo, FloR and Smilo systems: 150 transmitters can be entered! Input for photocells and possibility of connecting photo-test with self-learning function during installation.

**Safe:** obstacle detection system and automatic programming of the working times; motor absorption is monitored during movement, self-diagnosis by means of a flashing light and courtesy light. Acceleration and deceleration can be adjusted at the beginning and end of each opening and closing manoeuvre. Can be connected with last generation sensitive edges 8.2 KOhm.

CODE	DESCRIPTION
<b>SPIN10KCE</b>	KIT FOR AUTOMATING SECTIONAL AND UP-AND-OVER DOORS. 3X1 m-SECTIONS LINEAR GUIDE
<b>SPIN11KCE</b>	KIT FOR AUTOMATING SECTIONAL AND UP-AND-OVER DOORS. 3 m PRE-ASSEMBLED GUIDE

**N.B.** The content of the package may vary: consult the retailer.

## TECHNICAL SPECIFICATIONS

CODE	SN6011
<b>ELECTRICAL DATA</b>	
POWER SUPPLY (Vac 50/60 Hz)	230
ABSORPTION (A)	0.7
POWER (W)	200
<b>PERFORMANCE DATA</b>	
SPEED (m/s)	0.14
FORCE (N)	550
WORK CYCLE (CYCLES/DAY)	30
<b>DIMENSIONAL AND GENERAL DATA</b>	
PROTECTION LEVEL (IP)	40
WORKING TEMP. (°C MIN/MAX)	-20 ÷ +50
DIMENSIONS (mm)	225x330x100 h
WEIGHT (kg)	3.3

## UTILISATION LIMITS

Using the maximum travel

	NON-PROJECTING UP-AND-OVER DOOR		PROJECTING UP-AND-OVER DOOR		SECTIONAL	
	H	L	H	L	H	L
<b>SPIN10KCE</b>	2.2 m	3.5 m	2.8 m	3.5 m	2.4 m	3.7 m
<b>SPIN11KCE</b>	2.2 m	3.5 m	2.8 m	3.5 m	2.4 m	3.7 m

## DIMENSIONS

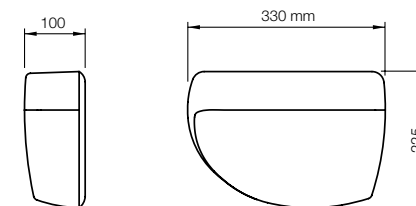

## THE KIT CONTAINS:

**SN6011**  
1 GEAR MOTOR SN6011 WITH INCORPORATED CONTROL UNIT AND PLUG-IN RECEIVER.



**FLO2RE**  
1 TRANSMITTER  
433.92 MHz, 2 CHANNELS.



**SPIN10KCE**  
GUIDE  
IN THREE 1-METRE SECTIONS.

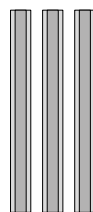

3 x 1 m

**SPIN11KCE**  
GUIDE  
IN ONE 3-METRE SECTION.



1 x 3 m





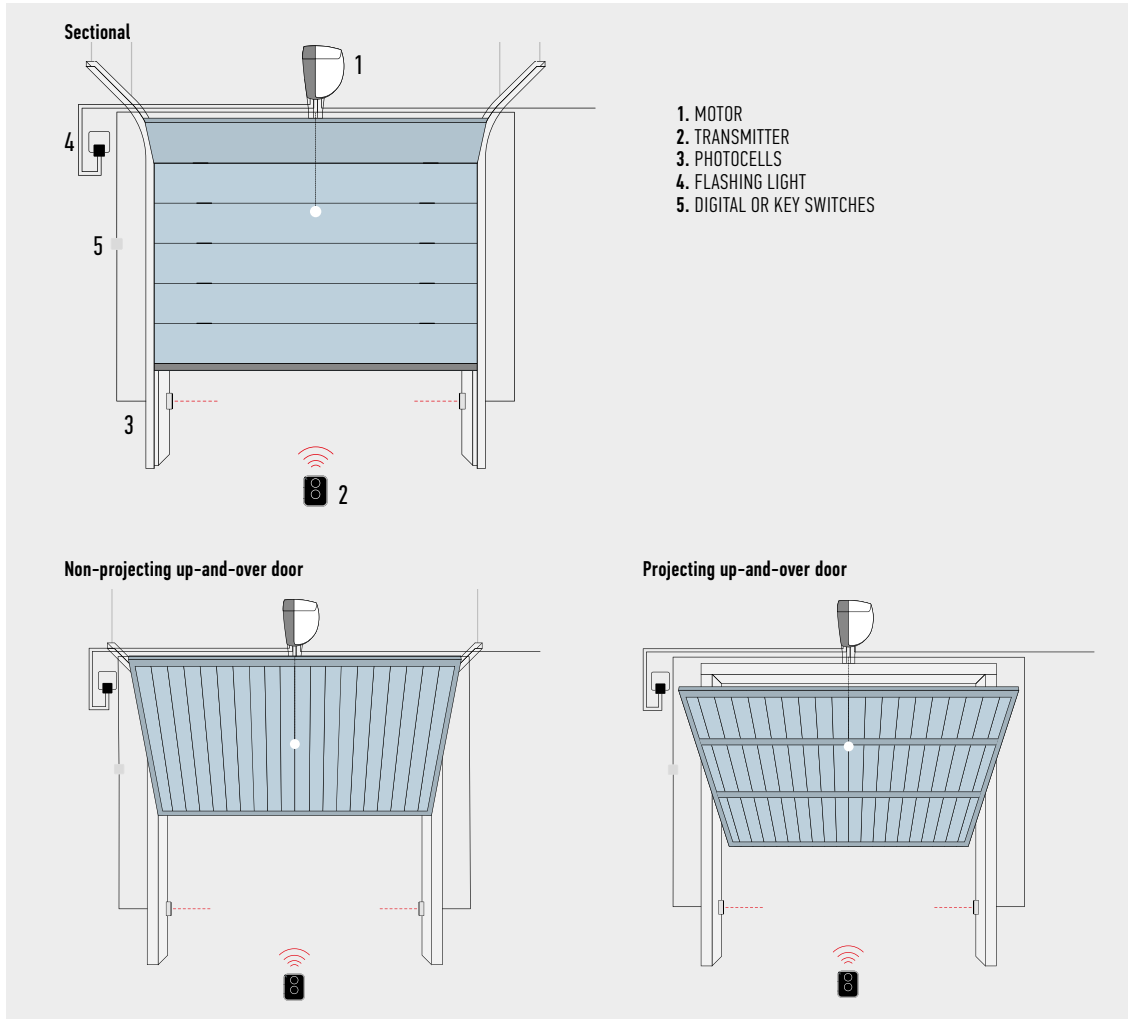



## INSTALLATION DIAGRAM



Nice recommends customers order products in order to facilitate storage and delivery, and ensure packs are uniform. The number of packs per single pallet has been specified for this reason. Approximate draft.

## ACCESSORIES

				FOR SWING GATES
<p><b>SNA1</b> SPARE CONTROL UNIT FOR SPIN10KCE AND SPIN11KCE.</p>	<p><b>SPA2</b> KIT FOR UNLOCKING FROM THE OUTSIDE WITH CABLE. PC/PACK 1</p>	<p><b>SPA5</b> OSCILLATING ARM SLIDING ON BEARINGS WITH OPTIMISED STRUCTURE FOR PROJECTING UP-AND-OVER DOORS. PC/PACK 1</p>	<p><b>SPA6</b> LARGE 585 mm LONG CONNECTING ARM. PC/PACK 1</p>	FOR SLIDING GATES
				BARRIER GATE OPERATOR SYSTEMS
<p><b>SPA7</b> KIT OF TWO ADDITIONAL FIXING BRACKETS. PC/PACK 2</p>	<p><b>SNA16</b> QUICK-CONNECT BRACKETS FOR CEILING MOUNTING. PC/PACK 10</p>	<p><b>TS</b> SIGNBOARD. PC/PACK 1</p>		FOR GARAGE AND INDUSTRIAL DOORS
				CONTROL SYSTEMS AND ACCESSORIES
				COMPATIBILITY TABLE AND ALPHABETICAL INDEX

**For projecting and non projecting up-and-over doors up to 9 m<sup>2</sup> (up to 16 m<sup>2</sup> using 2 motors). 24 Vdc electromechanical gear motor.**

**Three versions, standard and upgraded:**

- with built-in control unit, force regulator and absolute encoder (TN2010L);
- with incorporated control unit and receiver, electromechanical limit switch (TN2030L);
- without control unit (TN2020L).

**Reliable and precise:** memorisation of the opening and closing limit switch positions; gradual starting and slowdown during closing.

**Safe:** obstacle detection system and monitoring of the motor absorption during movement, self-diagnosis by means of a flashing light, courtesy light. The latest generation optical and resistive 8.2 KOhm sensitive edges can also be connected.

**Functional:** possibility to connect a second motor without control unit TN2020L, to automate doors up to 16 m<sup>2</sup>.

**TN2030L model with built-in radio receiver compatible with Nice system Flo, FloR and Smilo.**

**TN2010L version with BlueBUS technology and compatible for operation with Solemyo and Opera systems.**

**Advanced:** the absolute encoder technology guarantees precision without the need of a limit switch, reliability and the long term safeguard of the set values.

**Simple:** thanks to the BlueBUS technology which enables connection by means of just two wires between the control unit and photocells.

**Energy saving:** the system enters in stand-by when not in use.

**Practical:** the control unit and PS324 buffer battery (optional) can be connected by means of a simple connector and can be housed directly inside the motor.

Compatible with Nice SMXI and OXI plug-in receivers (optional).



CODE	DESCRIPTION	PACK/PALLET
TN2010L	IRREVERSIBLE, 24 Vdc, WITH INCORPORATED CONTROL UNIT, COURTESY LIGHT, ABSOLUTE ENCODER WITH BLUEBUS TECHNOLOGY, COMPATIBLE FOR OPERA AND SOLEMYO SYSTEMS. UPGRADED VERSION	15
TN2030L	IRREVERSIBLE, 24 Vdc, WITH INCORPORATED CONTROL UNIT AND RECEIVER, COURTESY LIGHT AND ELECTROMECHANICAL LIMIT SWITCH. UPGRADED VERSION	15
TN2020L	IRREVERSIBLE, 24 Vdc, WITH COURTESY LIGHT, WITHOUT INCORPORATED CONTROL UNIT. UPGRADED VERSION	15

**TECHNICAL SPECIFICATIONS**

CODE	TN2010L	TN2010L+TN2020L	TN2030L	TN2030L+TN2020L
<b>ELECTRICAL DATA</b>				
POWER SUPPLY (Vac 50/60 Hz)	230			
ABSORPTION (A)	1	1.4		1.4
POWER (W)	240	350	220	330
<b>PERFORMANCE DATA</b>				
SPEED (rpm)	1.4	1.7	1.4	1.4
TORQUE (Nm)	600	750	420	700
WORK CYCLE (CYCLES/HOUR)	15	25	20	10
<b>DIMENSIONAL AND GENERAL DATA</b>				
PROTECTION LEVEL (IP)	44			
WORKING TEMP. (°C MIN/MAX)	-20 ÷ +50			
DIMENSIONS (mm)	150x158x512 h			
WEIGHT (kg)	10	17.2*	9.5	16.7*

\* 7.2 for TN2020/TN2020L

**UTILISATION LIMITS**

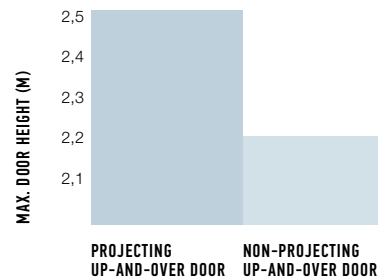

**DIMENSIONS**

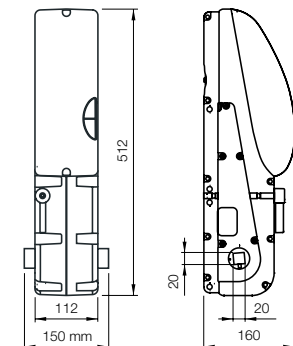

N.B. The values indicated above refer to the use of motors with standard accessories.

## INSTALLATION DIAGRAM

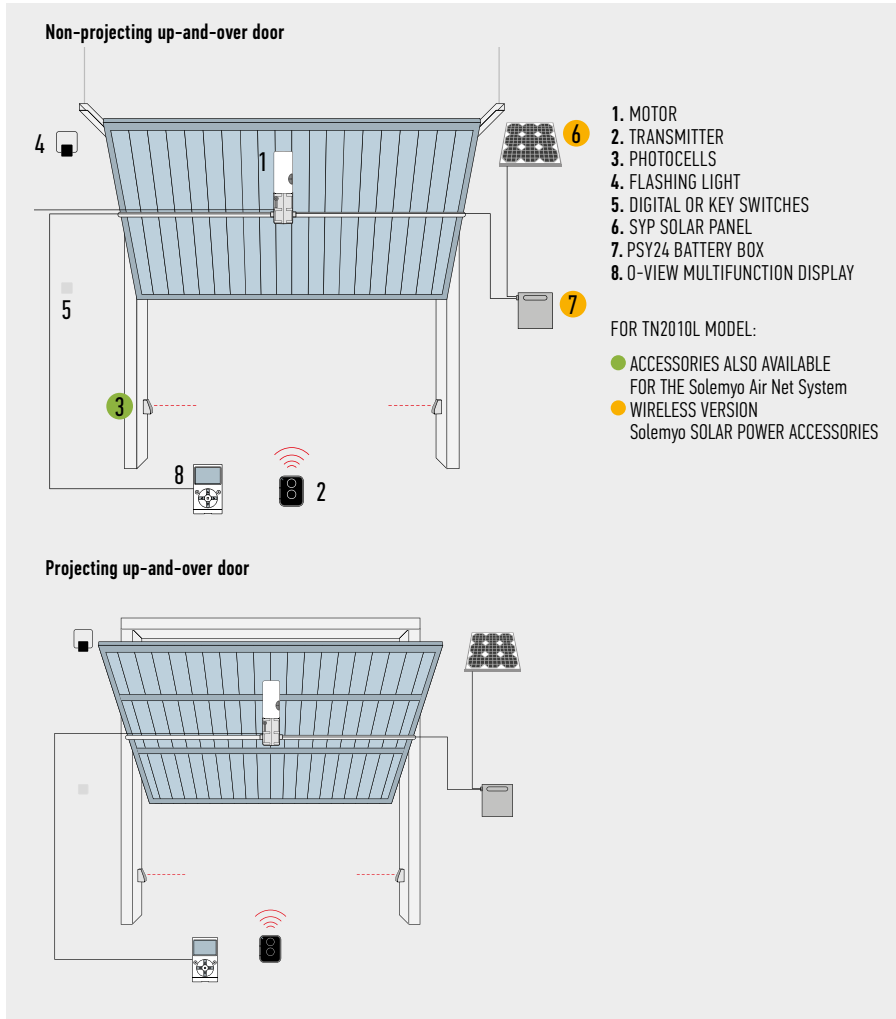

## COMPATIBILITY

CODE	RECEIVER		TRANSMITTER				PHOTOCELLS								FLASHING LIGHT						
	Built-in*	FLOX/ZR*	OXI	ERA INTI	ERA ONE	ERA FLOR	NICEWAY	EPS	EPM	EPL	EPSB	EPMB	EPLB	FZ10	FTZ10	FZ10B	FTZ10B	EL	ELZ4	ELB	WLT
TN2010L			●	●	●	●	●	●	●	●	●	●	●	●	●	●	●			●	●
TN2030L	●			●	●	●	●	●	●	●				●	●					●	●

\*Radio receiver incompatible with Opera system

## ACCESSORIES

<b>TNA1</b> SPARE CONTROL UNIT FOR TN2030L AND TNLKCE.	<b>TNA2</b> SPARE CONTROL UNIT FOR TN2010L.	<b>PS324</b> 24 V BATTERY WITH INTEGRATED BATTERY CHARGER. ONLY FOR TN2010L. PC/PACK 1	<b>TNA9</b> ADDITIONAL CONNECTION CABLE AND SUPPORTS FOR WALL-MOUNTING OF PS324 BATTERY. PC/PACK 1	<b>OTA2</b> MOTOR SUPPORT BRACKET (1250 mm LONG). PC/PACK 1
<b>OTA3</b> MOTOR SUPPORT BRACKET (2000 mm LONG). PC/PACK 1	<b>OTA9</b> MOTOR SUPPORT BRACKET (520 mm LONG). PC/PACK 1	<b>TNA5</b> PAIR OF STANDARD STRAIGHT TELESCOPIC ARMS. PC/PACK 1	<b>TNA6</b> PAIR OF STANDARD CURVED TELESCOPIC ARMS. PC/PACK 1	<b>TNA8</b> 20X20 mm DRIVE SHAFT (200 mm LONG). PC/PACK 1
<b>TNA4</b> 20X20 mm DRIVE SHAFT (1500 mm LONG). PC/PACK 1	<b>TNA38</b> DRIVING DEVICE FOR TRANSMISSION SHAFTS. PC/PACK 1	<b>OTA11</b> KIT FOR UNLOCK FROM THE OUTSIDE WITH A METAL CORD. PC/PACK 1	<b>OTA12</b> KIT FOR EXTERNAL UNLOCKING WITH KEY RATCHET (CANNOT BE USED WITH LATERALLY INSTALLED MOTORS). PC/PACK 1	<b>TS</b> SIGNBOARD. PC/PACK 1

FOR SWING GATES

FOR SLIDING GATES

BARRIER GATE  
OPERATOR SYSTEMS

FOR GARAGE  
AND INDUSTRIAL DOORS

CONTROL SYSTEMS  
AND ACCESSORIES

COMPATIBILITY TABLE  
AND ALPHABETICAL INDEX

# TENKIT

24V

## For projecting and non projecting up-and-over doors up to 9 m<sup>2</sup>.

Irreversible electromechanical 24 Vdc gear motor.

**Functions:** standard input for photocells and possibility of connecting phototest function in self-learning mode during installation.

**Convenient:** built-in radio board compatible with the systems Nice Flo, FloR e Smilo: possibility of entering up to 150 transmitters.

Push-button programming and automatic position search.

**Adjustments:** 3 force levels, 2 speeds, 3 pause time levels, 3 step-by-step modes.

**Maximum safety:** provision for connection of latest generation 8.2 KOhm sensitive edges.

Obstacle detection and automatic programming of work times, monitoring of motor absorption throughout travel, self-diagnostics via the flashing light and courtesy light. Acceleration and deceleration at the start and end of each manoeuvre.

CODE	DESCRIPTION	PACK/PALLET
TNLKCE	IRREVERSIBLE, 24 Vdc, WITH INCORPORATED CONTROL UNIT AND RECEIVER, COURTESY LIGHT AND ELECTROMECHANICAL LIMIT SWITCH. UPGRADED VERSION	15

**N.B.** The content of the package may vary; consult the retailer.

### TECHNICAL SPECIFICATIONS

CODE	TNLKCE
<b>ELECTRICAL DATA</b>	
POWER SUPPLY (Vac 50/60 Hz)	230
ABSORPTION (A)	0.9
POWER (W)	200
<b>PERFORMANCE DATA</b>	
SPEED (rpm)	1.4
TORQUE (Nm)	420
WORK CYCLE (CYCLES/HOUR)	15
<b>DIMENSIONAL AND GENERAL DATA</b>	
PROTECTION LEVEL (IP)	44
WORKING TEMP. (°C MIN/MAX)	-20 ÷ +50
DIMENSIONS (mm)	150x158x512 h
WEIGHT (kg)	15.5

### UTILISATION LIMITS

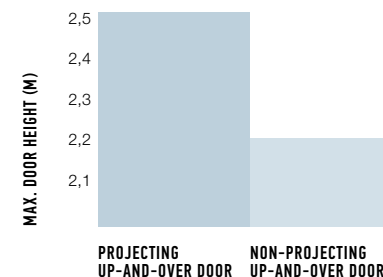

**N.B.** The values indicated above refer to the use of motors with standard accessories.

### DIMENSIONS

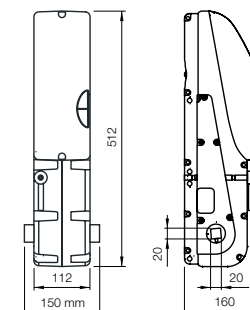

### THE KIT CONTAINS:

**TN2030L**  
1 IRREVERSIBLE ELECTROMECHANICAL GEAR MOTOR, WITH INCORPORATED CONTROL UNIT AND PLUG-IN RECEIVER, COURTESY LIGHT AND ELECTROMECHANICAL LIMIT SWITCH, COMPLETE WITH A PAIR OF STANDARD TELESCOPIC ARMS TNA5 AND WITH RELATIVE DRIVING DEVICES TNA38.



**FLO2RE**  
1 TRANSMITTER  
433.92 MHz, 2 CHANNELS.



**TS**  
1 SIGNBOARD.



## INSTALLATION DIAGRAM

### Non-projecting up-and-over door

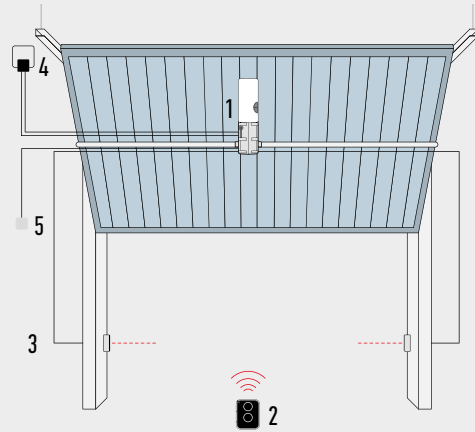

1. MOTOR
2. TRANSMITTER
3. PHOTOCELLS
4. FLASHING LIGHT
5. DIGITAL OR KEY SWITCHES

### Projecting up-and-over door

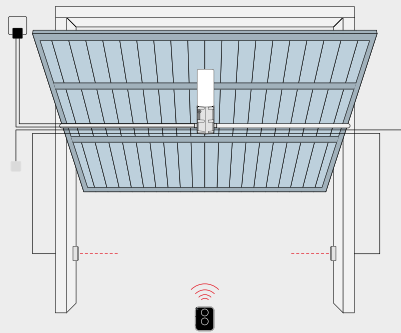

Nice recommends customers order products in pallets in order to facilitate storage and delivery, and ensure packs are uniform. The number of packs per single pallet has been specified for this reason. Approximate draft.

## ACCESSORIES



**TNA1**  
SPARE CONTROL UNIT  
FOR TNKCE AND TNLKE.



**OTA2**  
MOTOR SUPPORT BRACKET  
(1250 mm LONG).  
PC/PACK 1



**OTA3**  
MOTOR SUPPORT BRACKET  
(2000 mm LONG).  
PC/PACK 1



**OTA9**  
MOTOR SUPPORT BRACKET  
(520 mm LONG).  
PC/PACK 1



**TNA5**  
PAIR OF STANDARD STRAIGHT  
TELESCOPIC ARMS.  
PC/PACK 1



**TNA6**  
PAIR OF STANDARD CURVED  
TELESCOPIC ARMS.  
PC/PACK 1



**TNA8**  
20X20 mm DRIVE SHAFT  
(200 mm LONG).  
PC/PACK 1



**TNA4**  
20X20 mm DRIVE SHAFT  
(1500 mm LONG).  
PC/PACK 1



**TNA38**  
DRIVING DEVICE  
FOR TRANSMISSION  
SHAFTS.  
PC/PACK 1



**OTA11**  
KIT FOR UNLOCK  
FROM THE OUTSIDE  
WITH A METAL CORD.  
PC/PACK 1



**OTA12**  
KIT FOR EXTERNAL  
UNLOCKING WITH KEY  
RATCHET (CANNOT BE USED  
WITH LATERALLY INSTALLED  
MOTORS).  
PC/PACK 1



**TS**  
SIGNBOARD.  
PC/PACK 1

FOR SWING GATES

FOR SLIDING GATES

BARRIER GATE  
OPERATOR SYSTEMS

FOR GARAGE  
AND INDUSTRIAL DOORS

CONTROL SYSTEMS  
AND ACCESSORIES

COMPATIBILITY TABLE  
AND ALPHABETICAL INDEX

# SOON

SOLEMYO OPERA BLUEBUS 24V

**For sectional doors\* up to 20 m<sup>2</sup>.**  
24 Vdc electromechanical gear motor  
with absolute encoder.

\*For balanced sectional doors equipped with anti-crash  
(safety device useful in case of spring breaking).

**Easy to install:** Soon can be fitted directly onto the shaft  
of a sectional door; compact, particularly in width, in order  
to make assembly easy in any position.

**User-friendly thanks to the BlueBUS system**  
that enables users to connect the photocell couples  
and control unit using just two wires.

**Practical:** the control unit and PS124 buffer battery (optional)  
can be connected by means of a simple connector and can be  
housed directly inside the motor.

**Energy saving:** when the system is not being used it will  
switch over to standby.

**Reliable and precise:** memorization of limit switch positions  
on opening and closing; gradual starting and slowdown during  
closing; the absolute encoder technology guarantees precision  
without the need of a limit switch, reliability and long term  
safeguard of the set values.

**Safe:** obstacle detection system; motor absorption is monitored  
during movement, self-diagnosis by means of a flashing light  
and courtesy light.

Last generation of 8.2 KOhm optical and sensitive edges can also  
be connected.



CODE	DESCRIPTION	PACK/PALLET
S02000	IRREVERSIBLE, 24 Vdc, WITH ABSOLUTE ENCODER FOR DOORS UP TO 5 m IN HEIGHT	20

## TECHNICAL SPECIFICATIONS

CODE	S02000
<b>ELECTRICAL DATA</b>	
POWER SUPPLY (Vac 50/60 Hz)	230
ABSORPTION (A)	1.6
POWER (W)	350
<b>PERFORMANCE DATA</b>	
SPEED (rpm)	30
TORQUE (Nm)	50
WORK CYCLE (CYCLES/HOUR)	15
<b>DIMENSIONAL AND GENERAL DATA</b>	
PROTECTION LEVEL (IP)	40
WORKING TEMP. (°C MIN/MAX)	-20 ÷ +50
DIMENSIONS (mm)	115x300x375 h
WEIGHT (kg)	10.5

## DIMENSIONS

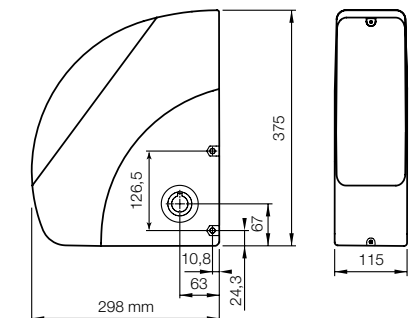

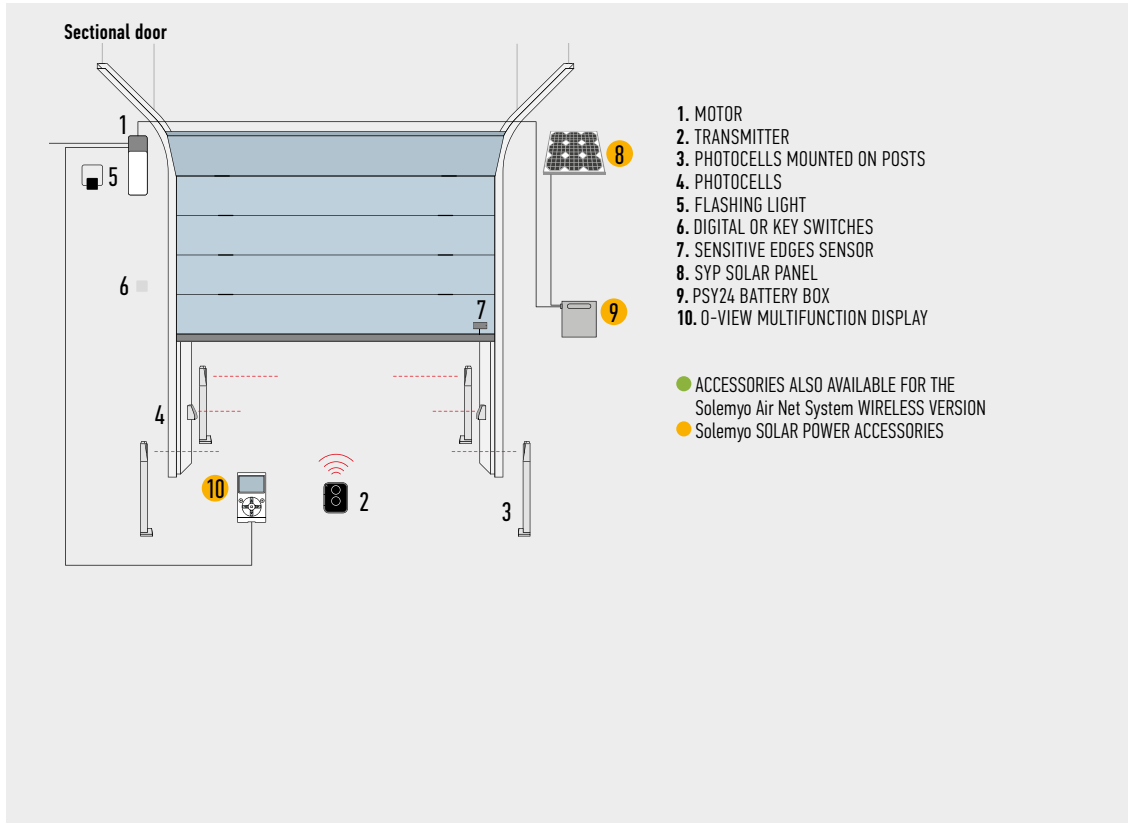

**COMPATIBILITY TABLE WITH CONTROL SYSTEMS AND ACCESSORIES**

CODE	RECEIVER		TRANSMITTER				PHOTOCELLS							FLASHING LIGHT							
	Built-in*	FLOX12R*	DXI	ERA INTI	ERA ONE	ERA FLOR	NICEWAY	EPS	EPM	EPL	EPSB	EPMB	EPLB	F210	FT210	F210B	FT210B	EL	EL24	ELB	WLT
<b>SO2000</b>			●	●	●	●	●				●	●	●			●	●			●	●

\*Radio receiver incompatible with Opera system

**ACCESSORIES**



**SOA2**  
SPARE CONTROL UNIT  
FOR SO2000.



**PS124**  
24 V BATTERY  
WITH INTEGRATED  
BATTERY CHARGER.

PC/PACK 1



**CRA9**  
ADAPTER FOR DIAMETER  
31.75 (1.1/4"), 35  
AND 40 mm SHAFTS.

PC/PACK 1



**TS**  
SIGNBOARD.

PC/PACK 1



**KIT SOLEMYO**  
THE SOLAR POWER TO  
AUTOMATE GATES, GARAGE  
DOORS OR BARRIER GATES.  
SEE PAGE 200

FOR SWING GATES

FOR SLIDING GATES

BARRIER GATE  
OPERATOR SYSTEMS

FOR GARAGE  
AND INDUSTRIAL DOORS

CONTROL SYSTEMS  
AND ACCESSORIES

COMPATIBILITY TABLE  
AND ALPHABETICAL INDEX

# SUMO

24V

## For sectional doors and two-wings sliding doors up to 35 m<sup>2</sup>.

24 Vdc electromechanical gear motor with magnetic encoder, no need to adjust limit switches.

Perfect for intensive use.

**Revolutionary aesthetics:** compact, particularly in width, in order to make assembly easy in any position; quick to install.

**Easy to install:** Sumo can be fitted directly onto the shaft of sectional doors.

Perfect for Ø 25.4 mm shafts and can be used also with Ø 31.75-35-40 mm shafts thanks to the CRA9 adapter.

## Many different functions with the separate Mindy A924 control unit:

- automatic memorization of limit switches on opening and closing;
- gradual departure and slowdown during closing;
- integrated battery charge card with optional battery power supply in the event of power failures easy programming by pressing a single button;
- pause time programming and speed adjustment;
- "service" warning light for maintenance (can be programmed according to the number of manoeuvre required).

CASE TOTALLY MADE FROM THICK DIE-CAST ALUMINIUM

INSPECTION COMPARTMENT, EASY TO ACCESS FOR CONNECTIONS

RELEASE CORD, 6.5 m LONG, WITH EMERGENCY HANDLE



CODE	DESCRIPTION	PACK/PALLET
SU2000	IRREVERSIBLE 24 Vdc, WITH MAGNETIC ENCODER, NO NEED TO ADJUST LIMIT SWITCHES, FROM 15 m <sup>2</sup> UP TO 35 m <sup>2</sup>	20
SU2000V	IRREVERSIBLE 24 Vdc, WITH MAGNETIC ENCODER, NO NEED TO ADJUST LIMIT SWITCHES, INCREASED SPEED, FROM 10 m <sup>2</sup> UP TO 25 m <sup>2</sup>	20
SU2000VV	IRREVERSIBLE 24 Vdc, WITH MAGNETIC ENCODER, NO NEED TO ADJUST LIMIT SWITCHES, HIGH SPEED, FROM 10 m <sup>2</sup> UP TO 15 m <sup>2</sup>	20
SU2010	IRREVERSIBLE 24 Vdc, WITH MAGNETIC ENCODER, NO NEED TO ADJUST LIMIT SWITCHES, IP54, FROM 15 m <sup>2</sup> UP TO 35 m <sup>2</sup>	20

## TECHNICAL SPECIFICATIONS

CODE	SU2000	SU2000V	SU2000VV	SU2010
<b>ELECTRICAL DATA</b>				
POWER SUPPLY (Vdc)	24			
ABSORPTION (A)	13			
POWER (W)	500			
<b>PERFORMANCE DATA</b>				
SPEED (rpm)	16	23.5	42	16
TORQUE (Nm)	120	82	46	120
WORK CYCLE (%)	50			
<b>DIMENSIONAL AND GENERAL DATA</b>				
PROTECTION LEVEL (IP)	44			54
WORKING TEMP. (°C MIN/MAX)	-20 ÷ +50			
DIMENSIONS (mm)	110x270x350 h			
WEIGHT (kg)	10.5			

## DIMENSIONS

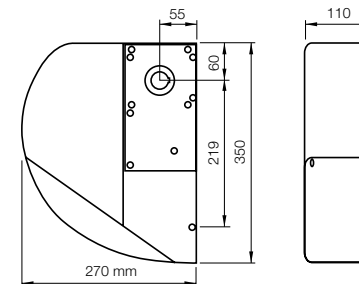



Nice recommends customers order products in pallets in order to facilitate storage and delivery, and ensure packs are uniform. The number of packs per single pallet has been specified for this reason. Approximate draft.

## INSTALLATION DIAGRAM

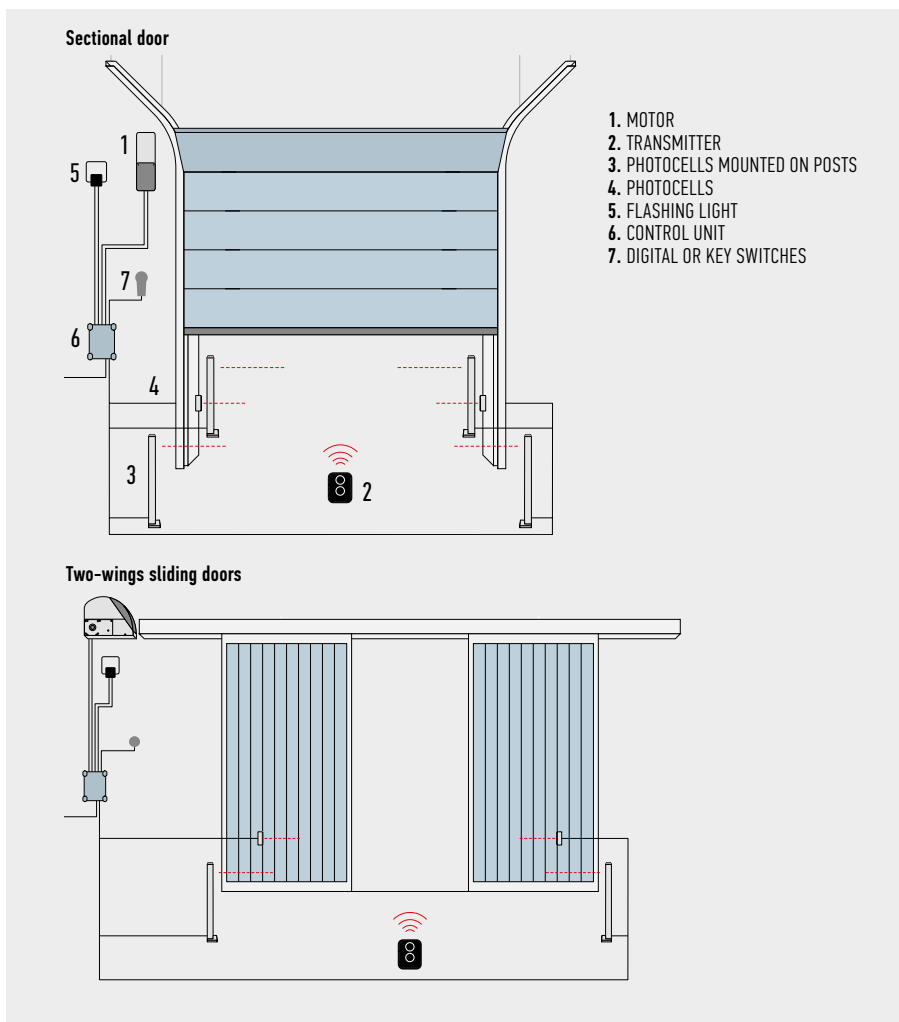

## COMPATIBILITY

CODE	CONTROL UNIT / REC.				TRANSMITTER				PHOTOCELLS								FLASHING LIGHT						
	A500 / FLOX12R*	A924 / FLOX12R*	MC424L / OXI	MC824H / OXI	MC824HR / OXI	ERA INTI	ERA ONE	ERA FLOR	NICEWAY	EPS	EPM	EPL	EPSB	EPMB	EPLB	F210	FT210	F210B	FT210B	EL	EL24	ELB	WLT
SU2000	●					●	●	●	●	●	●	●				●	●				●		
SU2000V	●					●	●	●	●	●	●	●				●	●				●		
SU2000VV	●					●	●	●	●	●	●	●				●	●				●		
SU2010	●					●	●	●	●	●	●	●				●	●				●		

## ACCESSORIES

 <b>A924</b> CONTROL UNIT. PC/PACK 1	 <b>PUL</b> CENTRAL COVER WITH BUTTONS, COMPLETE WITH CONNECTING CABLE AND CONNECTED FOR A500 AND A924. PC/PACK 1	 <b>B12-B</b> 12 V, 6 Ah BATTERIES. PC/PACK 1	 <b>BA3-A</b> NICE BATTERY BOX.	 <b>K10</b> KEY-OPERATED SELECTOR SWITCH FOR LOW VOLTAGE CONTACTS WITH RELEASE MECHANISM FOR METAL CORD. PC/PACK 1
 <b>KA1</b> 6 m CABLE RELEASE KIT FOR K10. NOT REQUESTED FOR SU2010. PC/PACK 1	 <b>CRA1</b> SHAFT WITH 18-TOOTH PINION Ø SHAFT 25.4 mm Ø INSIDE CROWN 25.4 mm. PC/PACK 1	 <b>CRA2</b> JOINT FOR CHAIN. PC/PACK 1	 <b>CRA3</b> 1/2" CHAIN, 1 m PACK, PLUS JOINT FOR CHAIN. PC/PACK 1	 <b>CRA4</b> 1/2" CHAIN, 5 m PACK, IDEAL FOR SINGLE OR DOUBLE WING INDUSTRIAL DOORS, PLUS JOINT FOR CHAIN. PC/PACK 1
 <b>CRA5</b> TENSIONER DRIVE WITH BRACKETS, FOR SINGLE OR DOUBLE WING INDUSTRIAL DOOR. PC/PACK 1	 <b>CRA6</b> 36-TOOTH PINION Ø INSIDE 25.4 mm. PC/PACK 1	 <b>CRA7</b> 18-TOOTH PINION Ø INSIDE 25.4 mm. PC/PACK 1	 <b>CRA8</b> WALL-FIXING BRACKET. PC/PACK 2	 <b>CRA9</b> ADAPTER FOR DIAMETER 31.75 (1.1/4"), 35 AND 40 mm SHAFTS. PC/PACK 1
			 <b>TS</b> SIGNBOARD. PC/PACK 1	 WARNING SIGNBOARD

FOR SWING GATES

FOR SLIDING GATES

BARRIER GATE OPERATOR SYSTEMS

FOR GARAGE AND INDUSTRIAL DOORS

CONTROL SYSTEMS AND ACCESSORIES

COMPATIBILITY TABLE AND ALPHABETICAL INDEX

# HYPP0 7100

SOLEMYO OPERA BLUEBUS 24V 230V

## For 2-leaf folding doors.

Electromechanical gear motor irreversible with telescopic arm, also in 24 Vdc version, with magnetic encoder.

Single model for right and left leaves.

Pre-wired, **incorporated double limit-switch** both during opening and closing; fewer connections mean quicker installation (for HY7100 only).

**Solid metal mechanics.**

**Sturdy, galvanised, telescopic arm.**

### Recommended control units:

for HY7100 Mindy A6F, A60, A700F;

for HY7124 Moonclever MC824H.

**24 Vdc version** with magnetic encoder.

**Perfect for intensive use**, compatible with the control unit Moonclever MC824H:

- simple programming, by means of a single key;
- self-learning of opening and closing limit positions;
- automatic fault diagnostics;
- programming of pause time;
- pedestrian pass door;
- deceleration on opening and closing;
- obstacle detection with dual technology;
- operation in event of power failure by means of optional rechargeable batteries (PS324);
- Can be connected with latest generation sensitive edges 8.2 KOhm.

COMPACT, SHOCKPROOF BODYWORK WITH NO SHARP CORNERS



NICE ALUMINIUM RELEASE, DESIGNED TO ACCOMMODATE EXTERNAL RELEASE

CODE	DESCRIPTION	PACK/PALLET
HY7100	IRREVERSIBLE, 230 Vac, WITH STURDY TELESCOPIC ARM, GALVANISED AND PAINTED, WITH LIMIT SWITCH ON OPENING AND CLOSING	16
HY7124	IRREVERSIBLE, 24 Vdc WITH MAGNETIC ENCODER, WITH TELESCOPIC ARM, GALVANISED AND PAINTED	16

## TECHNICAL SPECIFICATIONS

CODE	HY7100	HY7124
<b>ELECTRICAL DATA</b>		
POWER SUPPLY (Vac 50 Hz)*	230	-
POWER SUPPLY (Vdc)	-	24
ABSORPTION (A)	1.2	5
POWER (W)	250	120
<b>PERFORMANCE DATA</b>		
SPEED (rpm)	1.7	2
TORQUE (Nm)	400	250
WORK CYCLE (%)	30	80
<b>DIMENSIONAL AND GENERAL DATA</b>		
PROTECTION LEVEL (IP)	20	
WORKING TEMP. (°C MIN/MAX)	-20 ÷ +50	
DIMENSIONS (mm)	350x165x242 h	
WEIGHT (kg)	13	

\*60 Hz version available on request.

## UTILISATION LIMITS

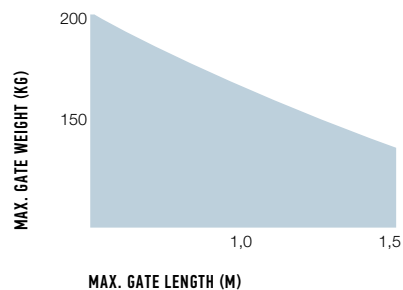

## DIMENSIONS

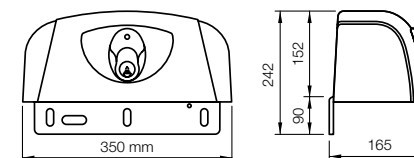

N.B. The above values are valid if the motor is used with standard accessories.

## INSTALLATION DIAGRAM

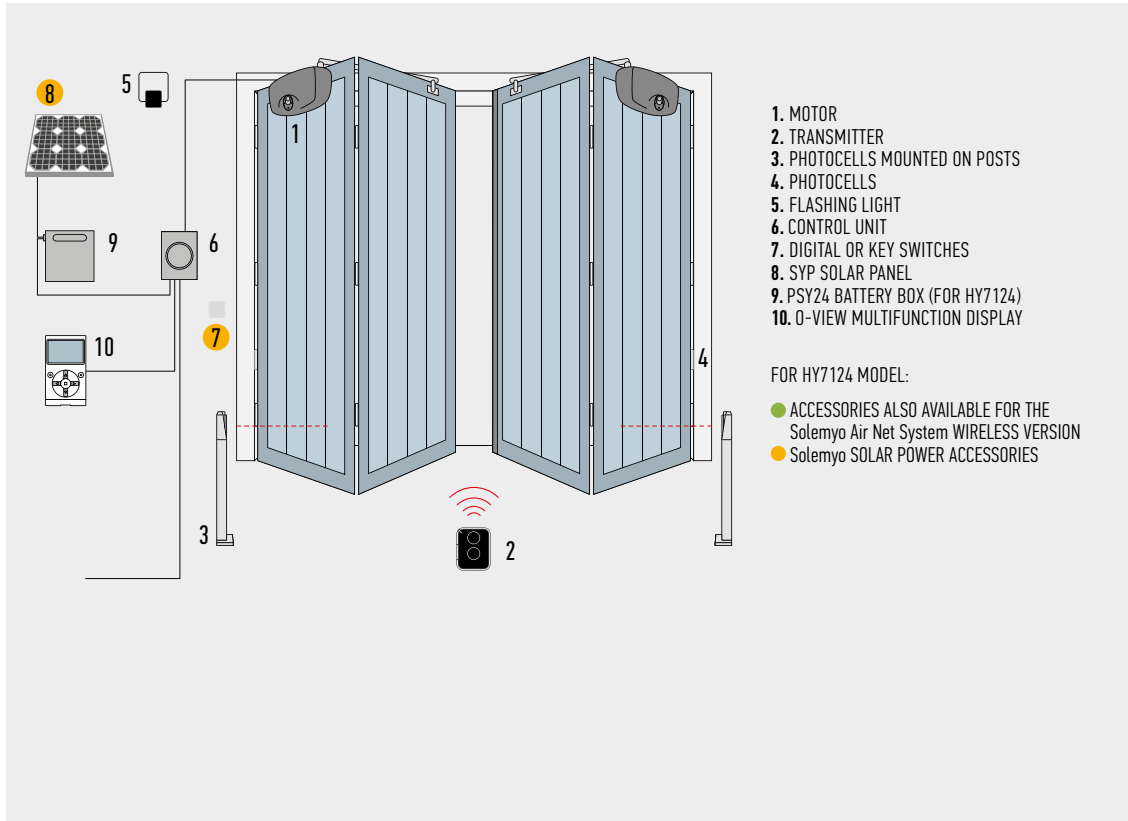

## COMPATIBILITY TABLE WITH CONTROL SYSTEMS AND ACCESSORIES

CODE	CONTROL UNIT / RECEIVER								TRANSMITTER				PHOTOCELLS								FLASHING LIGHT							
	A01 / Built-in*	A02 / Built-in*	A6F / FLOX12R*	A700F / FLOX12R*	A60 / OXI-SMX1*	A500 / FLOX12R*	A924 / FLOX12R*	MC424L / OXI	MC824H / OXI	MC824HR / OXI	ERA INTI	ERA ONE	ERA FLOR	NICEWAY	EPS	EPM	EPL	EP8B	EPMB	EPLB	F210	FT210	F210B	FT210B	EL	EL24	ELB	WLT
HY7100			●	●	●					●	●	●	●				●	●	●	●	●							
HY7124								●		●	●	●	●				●	●	●				●			●	●	

\*Radio receiver incompatible with Opera system

## ACCESSORIES



**HYA11**  
UNLOCK FROM INSIDE  
WITH A 6 m CORD.  
PC/PACK 1



**K10**  
KEY-OPERATED SELECTOR  
SWITCH FOR LOW VOLTAGE  
CONTACTS, WITH RELEASE  
MECHANISM FOR METAL CORD.  
PC/PACK 1



**KA1**  
6 m CABLE RELEASE KIT  
FOR K10.  
PC/PACK 1



**TS**  
SIGNBOARD.  
PC/PACK 1

### ACCESSORY

For 24 Vdc version



**PS324**  
24 V BATTERY  
WITH INTEGRATED  
BATTERY CHARGER.  
PC/PACK 1



**KIT SOLEMYO**  
THE SOLAR POWER TO  
AUTOMATE GATES, GARAGE  
DOORS OR BARRIER GATES.  
SEE PAGE 200

# NICE FOR BALANCED ROLLING DOORS

# SELECTION GUIDE

230 Vac,  
with electromechanical  
limit switch.  
**GIRO**  
pages 150/151

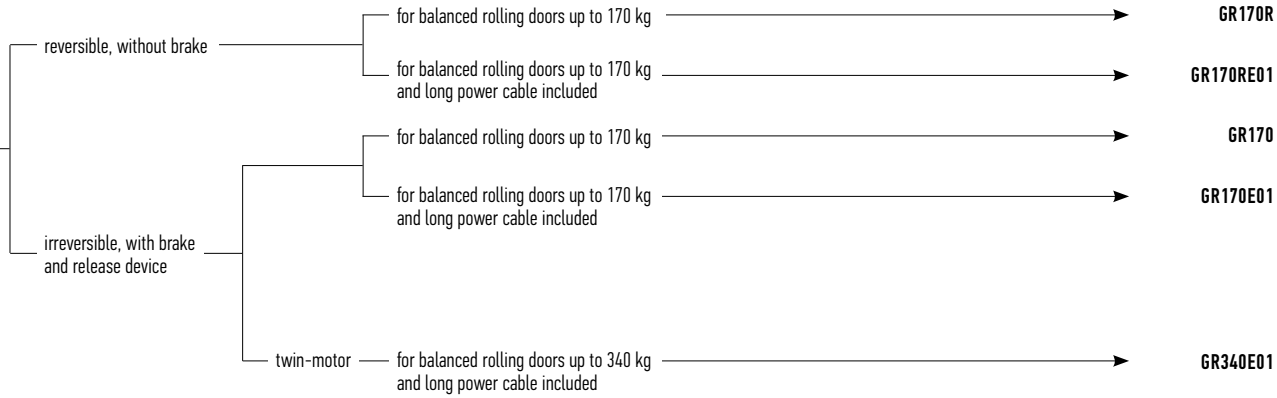

230 Vac,  
with electromechanical  
limit switch.  
**RONDO**  
pages 152/153

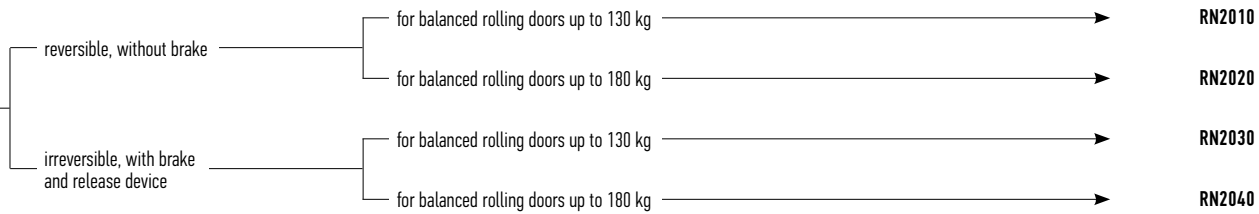

FOR SWING GATES

FOR SLIDING GATES

BARRIER GATE  
OPERATOR SYSTEMS

FOR GARAGE  
AND INDUSTRIAL DOORS

CONTROL SYSTEMS  
AND ACCESSORIES

COMPATIBILITY TABLE  
AND ALPHABETICAL INDEX

# GIRO

230V

## For balanced rolling shutters up to 170 kg and 340 kg.

Electromechanical gearmotor available both in reversible and irreversible version.

**High performance:** new irreversible twin-motor version with 800 W power and lifting force up to 340 Nm.

**Unbeatably flexible use and less inventory to keep in stock:** a single model that is designed to take a 76 mm rolling shutter shaft but can be easily adapted to take a 60 or 48 mm shaft, covering the full range of most commonly used sizes.

The outside diameter of the gear can be adapted from 200 mm to 220 or 240 mm, allowing installation on most rolling shutters.

**Technologically innovative:** the brake is built into the gearmotor and results in much smoother operation than the traditional solution.

**For all markets:** 230 and 120V versions available.

### QUICK AND EASY INSTALLATION

**During installation, the motor is supported on the shaft thanks to the practical guided coupling.**

**Easy limit switch adjustment:** automatic limit switch adjustment is achieved by simply operating the rolling shutter without any load, with the motor released, and then just fine-tuning the system manually.

**Simple system for releasing both motors at the same time.**

**Recommended control units:** Mindy A01 and A02.

PRACTICAL: LIMIT SWITCHES FOR BOTH CLOSING AND OPENING, EASY TO ADJUST

VERSATILE: CAN BE USED WITH 76, 60 AND 48 mm SHAFTS



STRONG: 100% ALUMINIUM HOUSING

CODE	DESCRIPTION	PACK./PALLET
GR170	FOR BALANCED ROLLING DOORS UP TO 170 kg, 230 V IRREVERSIBLE, WITH BUILT-IN BRAKE AND RELEASE DEVICE	44
GR170E01	FOR BALANCED ROLLING DOORS UP TO 170 kg, 230 V IRREVERSIBLE, WITH BUILT-IN BRAKE AND RELEASE DEVICE, POWER CABLE, 5 m LONG, INCLUDED IN BOX	44
GR170R	FOR BALANCED ROLLING DOORS UP TO 170 kg, REVERSIBLE 230 V, WITHOUT BRAKE	44
GR170RE01	FOR BALANCED ROLLING DOORS UP TO 170 kg, REVERSIBLE 230 V, WITHOUT BRAKE, 5 m LONG POWER CABLE INCLUDED	44
GR340E01	FOR BALANCED ROLLING DOORS UP TO 340 kg, IRREVERSIBLE 230 V, TWIN-MOTOR WITH BUILT-IN BRAKE AND RELEASE DEVICE, 5 m LONG POWER CABLE INCLUDED	44

### TECHNICAL SPECIFICATIONS

CODE	GR170/E01 GR170R/E01	GR340E01
<b>ELECTRICAL DATA</b>		
POWER SUPPLY (V/Hz)	230/50	
ABSORPTION (A)	1.9	3.3
POWER (W)	430	800
<b>PERFORMANCE DATA</b>		
SPEED (rpm)	8	
TORQUE (Nm)	170	340
CONTINUOUS OPERATING TIME (min)	4	
MAX. NUMBER OF OPERATIONS PER DAY	10	
<b>DIMENSIONAL AND GENERAL DATA</b>		
ROLLING SHUTTER SHAFT DIAMETER	76 - 60* - 48**	
OUTSIDE DIAMETER OF THE GEAR	200 - 220* - 240**	
PROTECTION LEVEL (IP)	20	
WORKING TEMP. (°C Min/Max)	-20 ÷ +50	
DIMENSIONS (mm)	∅ 200 x 380	
WEIGHT (kg)	7	10.5

\* with adapter included in box

\*\* with additional adapter (optional extra)

### DIMENSIONS

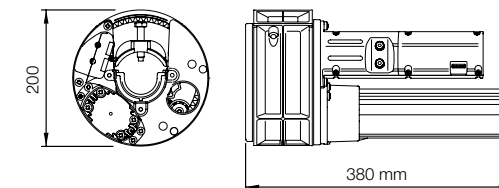

**TWIN-MOTOR VERSION:** MAXIMUM POWER, IDEAL FOR THE TOUGHEST APPLICATIONS.

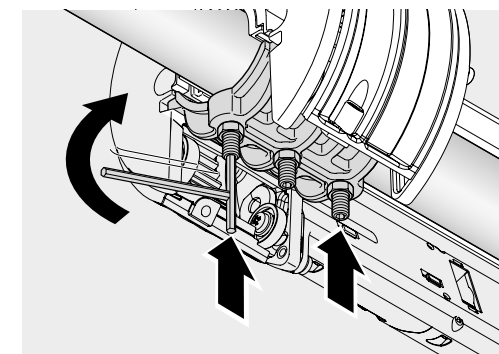

**QUICK AND EASY INSTALLATION** DURING INSTALLATION, THE MOTOR IS SUPPORTED ON THE SHAFT THANKS TO THE PRACTICAL GUIDED COUPLING.

## INSTALLATION DIAGRAM

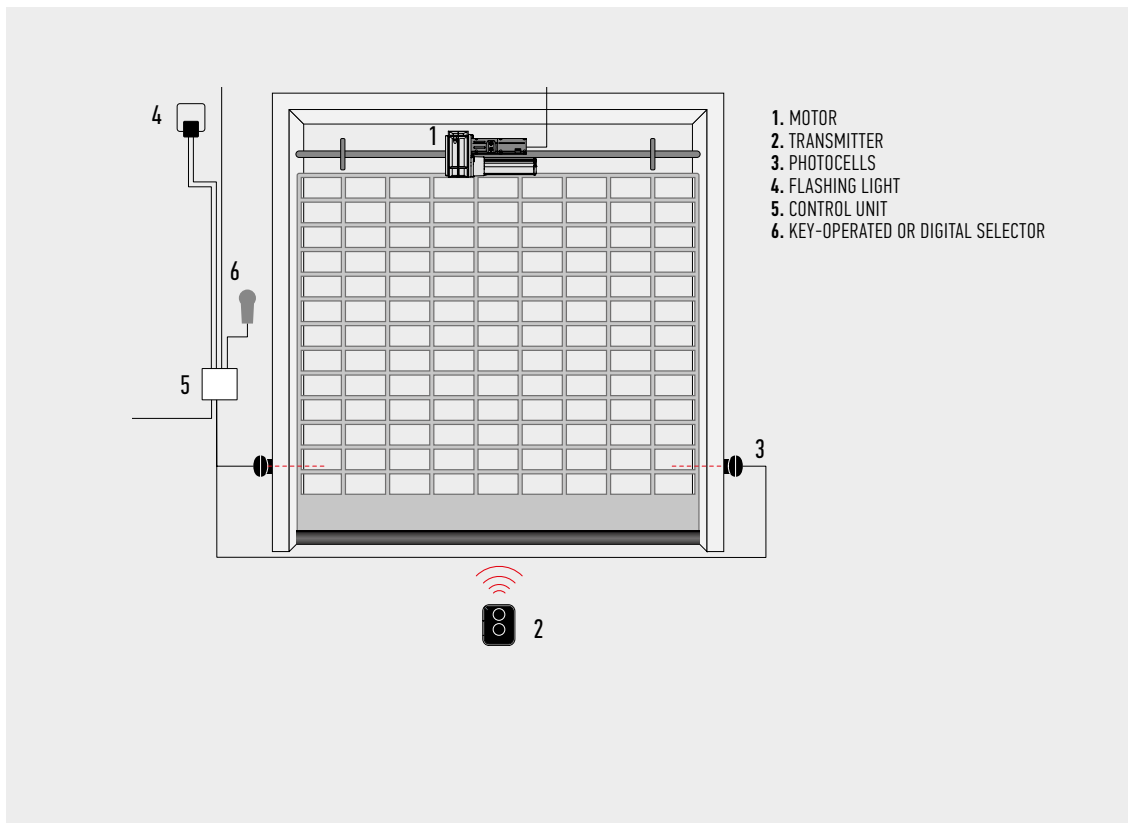

## COMPATIBILITY TABLE WITH CONTROL SYSTEMS AND ACCESSORIES

CODE	CONTROL UNIT / RECEIVER										TRANSMITTER				PHOTOCELLS						FLASHING LIGHT							
	A01 / Built-in*	A02 / Built-in*	A6F / FLOX12R*	A700F / FLOX2R*	A60 / OXI-SMXI*	A500 / FLOX12R*	A924 / FLOX12R*	MC424L / OXI	MC824H / OXI	MC824HR / OXI	ERA INTI	ERA ONE	ERA FLOR	NICEWAY	EPS	EPM	EPL	EPSB	EPMB	EPLB	F210	F7210	F210B	F7210B	EL**	EL24	ELB	WLT
GR170 / GR170E01	●	●									●	●	●	●	●	●					●	●			●			
GR170R / GR170RE01	●	●									●	●	●	●	●	●					●	●			●			
GR340E01	●	●									●	●	●	●	●	●					●	●			●			

\*Radio receiver incompatible with Opera system  
 \*\*Only with A02 control unit

## ACCESSORIES

**A01**  
CONTROL UNIT.  
PC/PACK 1

**A02**  
CONTROL UNIT WITH AUTOMATIC CLOSING.  
PC/PACK 1

**GRA02**  
ADAPTER FOR 48 mm SHAFT.  
PC/PACK 1

**GRA03**  
ADAPTER FOR 240 mm GEAR DIAMETER.  
PC/PACK 1

**GRA01**  
ADDITIONAL MOTOR FOR GR170, COMPLETE WITH ACCESSORIES FOR SIMULTANEOUS RELEASE.  
PC/PACK 1

**KIOMINI**  
ALUMINIUM KEY SWITCH/ SWITCH LOCK BOX WITH CONTROL AND RELEASE BUTTON.  
PC/PACK 1

**K10\***  
KEY SELECTOR FOR LOW-VOLTAGE CONTACTS, WITH RELEASE MECHANISM FOR METAL CABLE.  
For use in conjunction with A01 and A02-series control units.  
PC/PACK 1

**TS**  
SIGNBOARD.  
PC/PACK 1

Nice recommends customers order products in pallets in order to facilitate storage and delivery, and ensure packs are uniform. The number of packs per single pallet has been specified for this reason. Approximate draft.

FOR SWING GATES

FOR SLIDING GATES

BARRIER GATE OPERATOR SYSTEMS

FOR GARAGE AND INDUSTRIAL DOORS

CONTROL SYSTEMS AND ACCESSORIES

COMPATIBILITY TABLE AND ALPHABETICAL INDEX

# RONDO

230V

**For balanced rolling doors up to 130 kg and 180 kg.**  
Electromechanical gearmotor available both in reversible and irreversible version.

**Smart:** the limit switch unit and wiring are protected by an elegant box; pre-wired capacitor.

**Fast:** easy and intuitive adjustment of the limit switches both during opening and closing.

**Complete:** supplied with 200 mm and 220 mm flange for 60 mm shafts, with 48 mm and 42 mm adaptors.

**Easy to install:** thanks to the guided connector, you don't need to hold the motor while you secure it using just 3 screws.

**Recommended control units:**

Mindy A01 and A02, - easy to use, complete and reliable, featuring:

- semi-automatic or automatic operation;
- complete reverse run with photocell;
- step-by-step operation;
- programmable Step-by-step/Open input;
- programmable Stop/Photo input;
- input for resistive edge;
- incorporated radio card, compatible with the Nice Flo, FloR and Smilo systems.



COMPLETE: DESIGNED FOR CORDOPERATED RELEASE

STURDY: HOUSING IN 100% ALUMINIUM

PRACTICAL: EASY TO ADJUST, ELECTROMECHANICAL LIMIT SWITCHES BOTH DURING CLOSING AND OPENING

CODE	DESCRIPTION	PACK/PALLET
<b>RN2010</b>	FOR BALANCED ROLLING DOORS UP TO 130 kg, 230 V REVERSIBLE, WITHOUT BRAKE	35
<b>RN2020</b>	FOR BALANCED ROLLING DOORS UP TO 180 kg, 230 V REVERSIBLE, WITHOUT BRAKE	35
<b>RN2030</b>	FOR BALANCED ROLLING DOORS UP TO 130 kg, IRREVERSIBLE, WITH BRAKE AND RELEASE DEVICE	35
<b>RN2040</b>	FOR BALANCED ROLLING DOORS UP TO 180 kg, IRREVERSIBLE, WITH BRAKE AND RELEASE DEVICE	35

**TECHNICAL SPECIFICATIONS**

CODE	RN2010	RN2030	RN2020	RN2040
<b>ELECTRICAL DATA</b>				
POWER SUPPLY (Vac 50 Hz)*	230			
ABSORPTION (A)	2			2.6
POWER (W)	450			600
<b>PERFORMANCE DATA</b>				
SPEED (rpm)	10			
TORQUE (Nm)	130			180
WORK CYCLE MAX (%)	50% WITH 30 S ON AND 30 S OFF			
<b>DIMENSIONAL AND GENERAL DATA</b>				
PROTECTION LEVEL (IP)	20			
WORKING TEMP. (°C MIN/MAX)	-20 ÷ +50			
DIMENSIONS (mm)	Ø 210x338	Ø 210x355	Ø 210x338	Ø 210x385
WEIGHT (kg)	9.5		10	

\*60 Hz version available on request.

**DIMENSIONS**

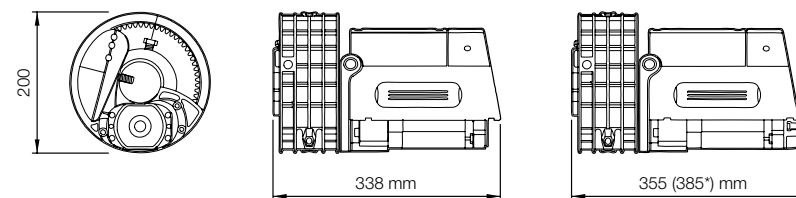



## INSTALLATION DIAGRAM

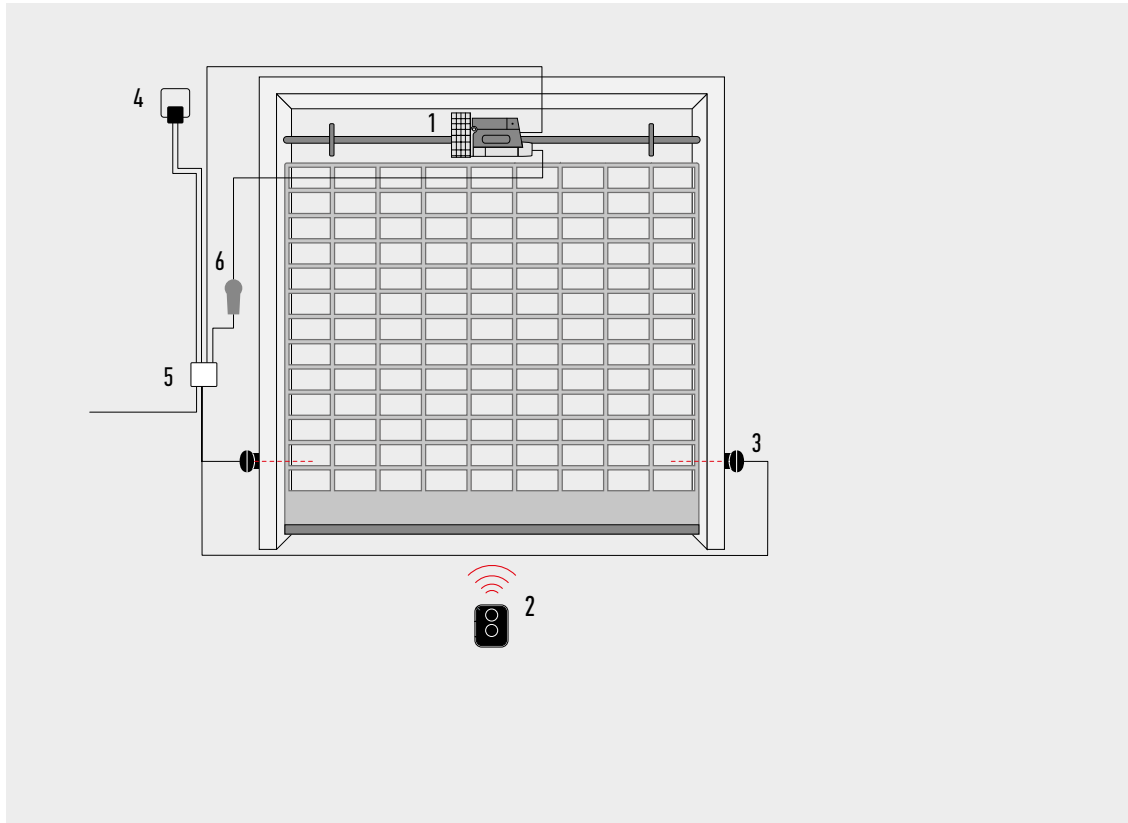

## COMPATIBILITY TABLE WITH CONTROL SYSTEMS AND ACCESSORIES

CODE	CONTROL UNIT / RECEIVER										TRANSMITTER				PHOTOCELLS						FLASHING LIGHT								
	A01 / Built-in*	A02 / Built-in*	A6F / FLOX12R*	A700F / FLOX12R*	A60 / OXI-SMXI*	A500 / FLOX12R*	A924 / FLOX12R*	MC424L / OXI	MC824H / OXI	MC824HR / OXI	ERA INTI	ERA ONE	ERA FLOR	NICEWAY	EPS	EPM	EPL	EPSB	EPMB	EPLB	F210	F7210	F210B	F7210B	EL**	EL24	ELB	WLT	
RN2010	●	●									●	●	●	●	●	●					●	●			●				
RN2020	●	●									●	●	●	●	●	●					●	●			●				
RN2030	●	●									●	●	●	●	●	●					●	●			●				
RN2040	●	●									●	●	●	●	●	●					●	●			●				

\*Radio receiver incompatible with Opera system  
\*\*Only with A02 control unit

## ACCESSORIES



**A01**  
CONTROL UNIT.  
PC/PACK 1



**A02**  
CONTROL UNIT  
WITH AUTOMATIC CLOSING.  
PC/PACK 1



**K10**  
KEY-OPERATED SELECTOR  
SWITCH FOR LOW VOLTAGE  
CONTACTS, WITH RELEASE  
MECHANISM FOR METAL  
CORD.  
PC/PACK 1



**RNA01**  
ELECTRONIC BRAKE  
FOR RN2020 AND RN2010.  
PC/PACK 1



**TS**  
SIGNBOARD.  
PC/PACK 1

FOR SWING GATES

FOR SLIDING GATES

BARRIER GATE  
OPERATOR SYSTEMS

FOR GARAGE  
AND INDUSTRIAL DOORS

CONTROL SYSTEMS  
AND ACCESSORIES

COMPATIBILITY TABLE  
AND ALPHABETICAL INDEX



# CONTROL SYSTEMS



ERA RANGE	158	ERA P VIEW
RADIO CONTROL SYSTEMS	160	ERA TOUCH
	162	ERA INTI
	164	ERA ONE
	165	ERA FLOR
	170	RECEIVERS

---

OTHER TRANSMITTERS AND RECEIVERS	166	NICEWAY
	170	RECEIVERS

---

OPERA SYSTEM	172	O-VIEW, O-BOX, OX4T
--------------	-----	------------------------

---

TAG SYSTEM	178	TTX4, TTXB4, TT2, TT1
------------	-----	--------------------------

# SIMPLE SOLUTIONS FOR COMPLEX INSTALLATIONS

Nice offers simple safe solutions to manage a large number of automations, lighting points and electrical loads.

## MANAGING A "GROUP"

Era Screen transmitters can be used to control single automations, automation groups and multigroups.

To connect a group of similar automations (gate only, awnings only) to a single key, during programming all the automations you want to activate together must be associated with that key.

## MANAGING MULTIGROUPS

With 6-channel transmitters, groups of different automations (awnings and rolling shutters) can also be created. These are known as "multigroups".

## INTEGRATION WITH OTHER SYSTEMS

As well as automation, transmitters in the Era line can also be used to manage outdoor lighting.

For example, if you connect the outdoor lights (for a maximum power of 1000 W/500 VA) to a receiver and a TT2L control unit, you can select one of the keys on the transmitter to control all of them together.

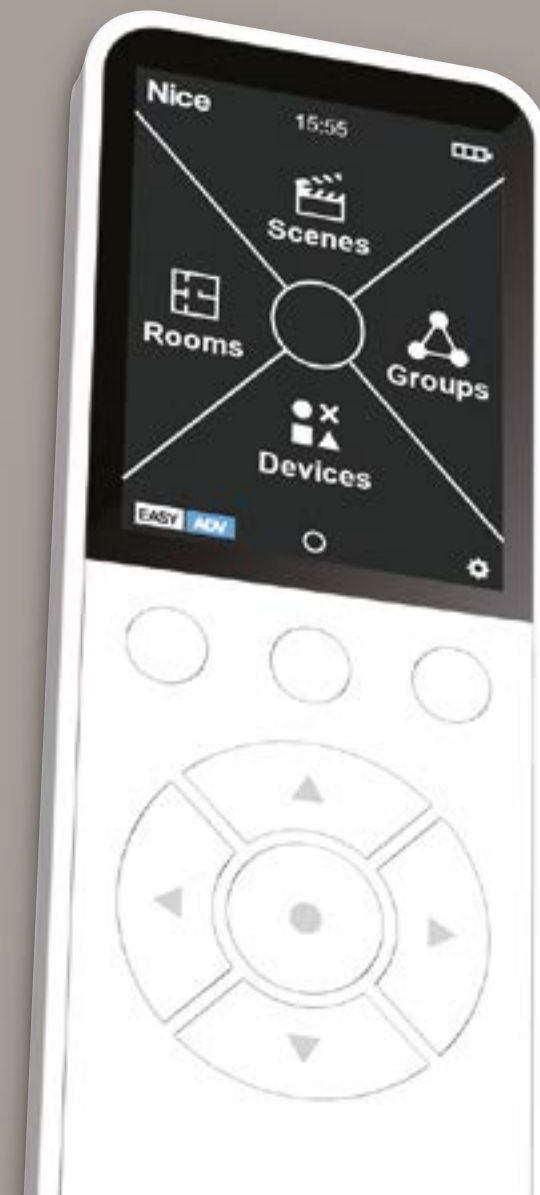

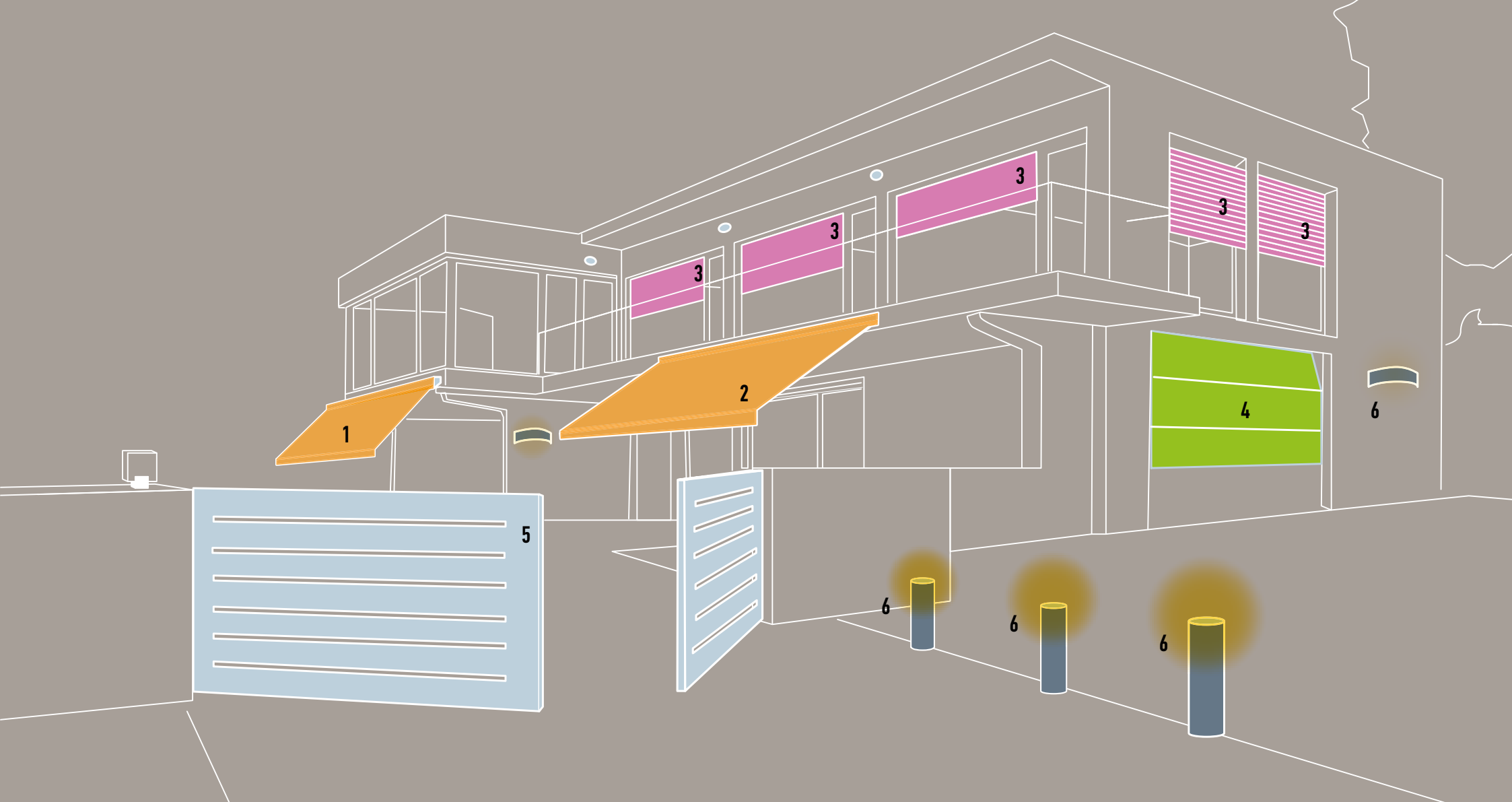

**LEGEND**

- 1. SINGLE AUTOMATION - AWNING
- 2. SINGLE AUTOMATION - AWNING
- 3. GROUP AUTOMATION - SOLAR SCREEN
- 4. SINGLE AUTOMATION - GARAGE DOOR
- 5. SINGLE AUTOMATION - GATE
- 6. GROUP - OUTDOOR LIGHTING

# ERA P VIEW

NEW

**Multifunction radio transmitter with intuitive graphic interface**, LCD colour screen (2.2") navigation by 5-key joypad.

To manage up to 99 devices singularly or in groups (20 zones, groups or scenarios).

With clock and calendar to configure timed commands.

**Advanced programming for professionals!**

The installer can access the transmitter and receiver programming and modify and create types and sets of commands. Direct access from first start-up by inserting the batteries or subsequently using the keys on the back of the transmitter.

**Easy to use for all requirements:** can be used in either simple or advanced mode.

## Advanced Users

Can modify the transmitter settings and the labels identifying the devices and create, time, modify and control zones, groups and scenarios. They can also limit access to the advanced menu by a numerical password.

## Easy Users

Can simply and directly control a small number of devices pre-authorized by the advanced user. They can consult the dashboard and suspend timed events.

## Practical and functional.

If not used for a few seconds, Era P View switches to stand-by to reduce battery consumption. Thanks to the built-in sensors, the device comes on again automatically when removed from the wall support or moved, or if any key is pressed.

**USB socket:** to recharge the batteries (if rechargeable).

With practical magnetic support for fixing to the wall.



CODE	DESCRIPTION	PCS./PACK.
ERA P VIEW	MULTIFUNCTION RADIO TRANSMITTER WITH INTUITIVE GRAPHIC INTERFACE, TO MANAGE UP TO 99 DEVICES SINGLY OR IN GROUPS	1

#### TECHNICAL SPECIFICATION

POWER SUPPLY	2 AAA 1.5V ALKALINE BATTERIES
BATTERY LIFETIME	ABOUT 1 YEAR WITH 20 OPERATIONS PER DAY
RADIO CODING	ROLLING CODE
FREQUENCY	433.92 MHz (±100 kHz)
RANGE	ESTIMATED 200 M IN OPEN SPACE AND 35 M INDOORS
USB SOCKET	MICRO USB
OPERATING TEMPERATURE (°C)	-20; +50
PROTECTION CLASS	IP 40
DIMENSIONS (mm)	200x50x15 (WITHOUT WALL SUPPORT)
WEIGHT (g)	140

#### IMMEDIATE AND INTUITIVE SELECTION OF THE DEVICE TO BE CONTROLLED THANKS TO THE GRAPHIC INTERFACES

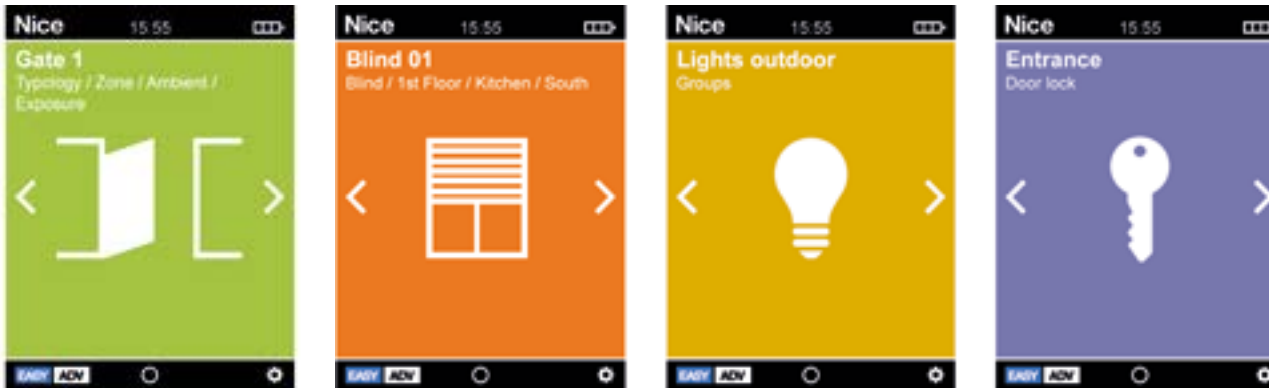

#### ADVANCED USERS: COMPLETE SELECTION MENU TO PROGRAMME AND MANAGE ALL DEVICES



FOR SWING GATES

FOR SLIDING GATES

BARRIER GATE  
OPERATOR SYSTEMS

FOR GARAGE  
AND INDUSTRIAL DOORS

CONTROL SYSTEMS  
AND ACCESSORIES

COMPATIBILITY TABLE  
AND ALPHABETICAL INDEX

# ERA TOUCH

## Touchscreen to control Nice automations and manage the NiceHome alarm system

The wireless Nice Era touchscreen can manage all home automations, thanks to remote control of:

- a maximum of 99 single controls,
- up to 10 groups of controls, to manage a number of automations of the same type simultaneously;
- up to 10 single scenarios, to manage different automations, including those associated with the alarm system.

By using Nice TT2L or TT2D miniaturised control units and/or universal receivers (es. SMX2R etc.) you can manage light, irrigation and heating (convector heaters, etc.).

Automations, groups and scenarios can be controlled in time bands thanks to the built-in weekly and hourly programmer.

Simple programming, configuration and control of the alarm system, with intuitive graphic display, built-in vocal guide and bidirectional technology.

**Built-in proximity transponder badge reader for the management of alarm system:** each individual key can be personalised for the single user and individual zones.

Thanks to the bidirectional wireless communication with the alarm system, the touchscreen displays alarm system status, indicating the status of each individual zone by means of simple icons.

### Main functions:

- Management of Nice automations with FLOR encoding: it can control up to 99 single automations divided into sun screens, gates, garages and lighting.
- Simultaneous management of the controls for blinds, shutters and sun screens automated with Nice tubular motors.
- Control of single automations, groups of automations and the execution of scenarios, with the possibility of attributing a name to each automation.
- Management of timed controls through the built-in weekly and hourly programmer.
- Four programmable buttons to control automations and/or groups and/or scenarios.
- Scenarios combined with event notifications enable the garden lights to be turned on and/or the shutters to be closed in the event of an alarm in the garden.
- Easy to update thanks to the mini-USB connector.

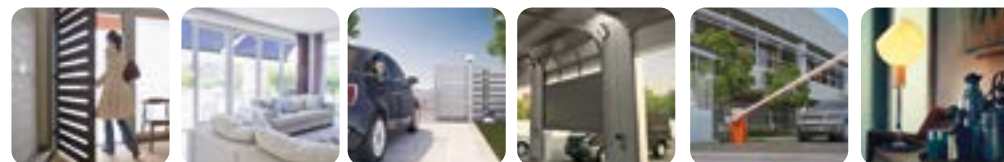

HSTSA1  
CHARGER BASE

HSB1  
TRANSPONDER BADGE



CODE	DESCRIPTION	PACK/PALLET
<b>HSTS2EN</b>	WIRELESS TOUCH SCREEN	1
<b>HSB1</b>	TRANSPONDER BADGES	10
<b>HSTA1</b>	CHARGER BASE FOR TOUCH SCREEN, WITH RECHARGEABLE BATTERIES INCLUDED	1

#### ACCESSORIES FOR TOTAL HOME MANAGEMENT:

CODE	DESCRIPTION	PACK/PALLET
<b>TT2N</b>	CONTROL UNIT FOR 230 Vac MOTOR WITH BUILT-IN RADIO RECEIVER	1
<b>TT2L</b>	CONTROL UNIT FOR MANAGEMENT OF 230 Vac LIGHTING SYSTEMS, WITH BUILT-IN RADIO RECEIVER	1
<b>TT2D</b>	CONTROL UNIT FOR MANAGEMENT OF 230 Vac LIGHTING SYSTEMS, WITH BUILT-IN RADIO RECEIVER AND SWITCHING MODULE	1
<b>FLOX2R</b>	UNIVERSAL RECEIVERS, 2 CHANNELS WITH BM250 MEMORY	1
<b>SMX2R</b>	UNIVERSAL RECEIVERS, 2 CHANNELS WITH 256-CODES MEMORY, PRE-WIRED	1



#### TECHNICAL SPECIFICATIONS

##### RADIO TRANSMISSION

FREQUENCY	433,92 MHz - 434,32 MHz
TIPO	DIGITAL BIDIRECTIONAL WITH HSCU2 ALARM SYSTEM
RANGE	100 m IN OPEN SPACE WITHOUT INTERFERENCE, 20 m INSIDE BUILDINGS

##### FUNCTIONS

DISPLAY	3.75" GRAPHIC 240x128 pixel, MONOCHROME BACKLIT
ON BUTTON	YES
CONFIGURABLE GROUPSI	10 CONFIGURABLE GROUPS OF SIMILAR AUTOMATIONS (SAME COMMANDS)
SCENARIOS	10 CONFIGURABLE SCENARIOS WITH COMMANDS CONTROLLING AUTOMATIONS AND ALARM ACTIVATION-DEACTIVATION
ACTIVATION TIMER	10 CONFIGURABLE
LED	BLUE - RADIO COMMUNICATION / RED - BATTERY FLAT / ORANGE - CHARGING / GREEN - FULLY CHARGED
FUNCTION BUTTONS	4 CONFIGURABLE
TRANSPONDER KEY READER	YES
MICROPHONE	YES
LOUDSPEAKER	0,5 W
VOICE RECORDER	5 MESSAGES FOR A TOTAL OF 120 S
SW UPDATING	YES BY MICRO-USB INPUT
MOVEMENT SENSOR	YES
EVENTS LOG	100

##### POWER SUPPLY

POWER SUPPLY	2 x 1.5 V AA ALKALINE BATTERIES SUPPLIED
AUTONOMY	ON AVERAGE MORE THAN A YEAR DEPENDING ON USE
SUPPLEMENTARY POWER SUPPLY	BY HSTA1 CHARGING BASE AND AA RECHARGEABLE BATTERIES CONNECTED TO THE MICRO-USB PORT

##### SYSTEM

WORKING TEMPERATURE	+5° C ÷ + 40° C (EN50131 ENVIRONMENTAL CLASS I)
DIMENSIONS	154x83x20 mm
WEIGHT	250 g

FOR SWING GATES

FOR SLIDING GATES

BARRIER GATE OPERATOR SYSTEMS

FOR GARAGE AND INDUSTRIAL DOORS

CONTROL SYSTEMS AND ACCESSORIES

COMPATIBILITY TABLE AND ALPHABETICAL INDEX

# ERA INTI

The colourful line of 1 and 2 channel miniaturised transmitters, available in six colours.

433.92 MHz rolling code, with management of Identity Codes and Certificates, self-learning and built-in proximity receiver; with 72 bit O-Code encoding, also compatible with receivers with Nice FLOR encoding.

**Evolved:** uses data processing and recognition systems that increase its degree of security and deliver a threefold reduction in automation response times.

**Easy memorisation, even at a distance,** thanks to Opera receivers.

There are two options for enabling a new Inti transmitter, even at a distance from the system:

- using a transmitter already programmed in the receiver, thanks to the enabling **Code exchange** between the two (figure 1);
- using the Nice O-Box connection interface; the receiver's **Certificate** is entered by just placing the new Inti next to the O-Box and following the guided procedure on a PC or PDA (figure 2).

**Safe,** if a transmitter is stolen or lost, with the O-Box the user can:

- **replace it,** maintaining the same functions as in the previous one, **disable** the old transmitter by increasing the priority level on the new Inti.

Inti can be used as keyring thanks to the lace included in the pack.

## TRANSMITTERS INTI

CODE	DESCRIPTION	PCS/PACK
INTI1Y	1 CHANNEL, 433.92 MHz, YELLOW	10
INTI2Y	2 CHANNEL, 433.92 MHz, YELLOW	10
INTI1R	1 CHANNEL, 433.92 MHz, RED	10
INTI2R	2 CHANNEL, 433.92 MHz, RED	10
INTI1L	1 CHANNEL, 433.92 MHz, LILAC	10
INTI2L	2 CHANNEL, 433.92 MHz, LILAC	10
INTI1G	1 CHANNEL, 433.92 MHz, GREEN	10
INTI2G	2 CHANNEL, 433.92 MHz, GREEN	10
INTI1B	1 CHANNEL, 433.92 MHz, BLUE	10
INTI2B	2 CHANNEL, 433.92 MHz, BLUE	10
INTI1	1 CHANNEL, 433.92 MHz, BLACK	10
INTI2	2 CHANNEL, 433.92 MHz, BLACK	10
INTIKIT	THE KIT CONTAINS: 3 TWO-CHANNEL INTI UNITS (COLOURS RED, GREEN AND BLUE) 1 OX2 RECEIVER.	

## TRANSMITTER TECHNICAL SPECIFICATIONS

	Carrier frequency	Estimated range	Encoding	Power supply	Battery life	Protection class	Dimensions Weight
INTI_Y, INTI_R, INTI_L, INTI_G, INTI_B, INTI	433.92 MHz	150 m (outdoors); 30 m (if inside buildings)*	O-Code 72 bit; rolling code	3 Vdc; lithium battery type CR2032	2 years (with 10 transmissions per day)	IP40 (use in protected environments)	30x56x9 h mm 14 g

\* Transmitter range and receiver reception capacity may be affected by any devices operating on the same frequency in the area.



**INTIKIT**  
THE KIT CONTAINS:  
3 TWO-CHANNEL INTI UNITS  
(COLOURS RED, GREEN AND BLUE)  
1 OX2 RECEIVER.

## UNINTIVERSAL!

**Inti, the universal control!  
Ideal for use in apartment  
blocks or multi-user systems.**

Easy and cheap to install: combined with the OX2 universal receiver, the Inti transmitter is able to control and manage any automation, including pre-installed systems.

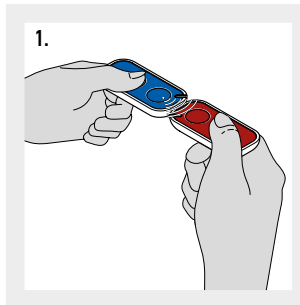

1. CODE EXCHANGE BETWEEN A MEMORIZED TRANSMITTER AND A NEW ONE, TO BE MEMORIZED.

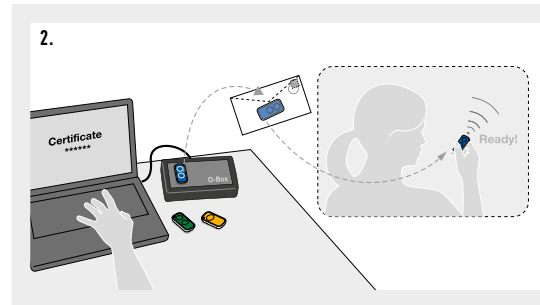

2. POSSIBLE MEMORISATION USING NICE O-BOX AND THE "CERTIFICATE"

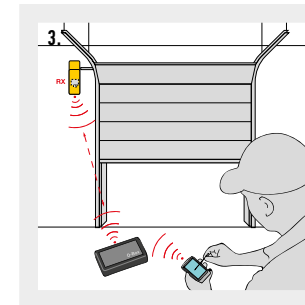

3. THE PRESENCE OF A "TRANSMITTER" IN THE OX1T, OX2T AND OX4T RECEIVERS ALLOWS RADIO CODES TO BE ACCESSED BY MEANS OF THE O-BOX MULTIFUNCTION INTERFACE.

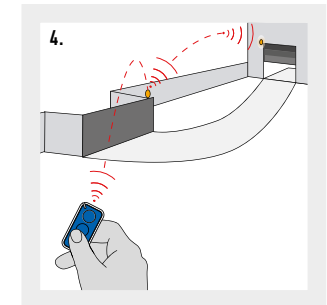

4. OX1T, OX2T AND OX4T RECEIVERS CAN BE USED AS SIGNAL REPEATERS.

# ERA ONE

The system includes 1, 2, 4 and 9 channel transmitters and prewired receivers with connector, with and without built-in transmitter.

433.92 MHz rolling code, with management of Identity Codes and Certificates, self-learning and built-in proximity receiver; with 72 bit O-Code encoding, also compatible with receivers with Nice FLOR encoding.

Available in versions with multiple input sequential encoding (Era OneC).

**Evolved:** uses data processing and recognition systems that increase its degree of security and deliver a threefold reduction in automation response times.

**Easy memorisation, even at a distance,** thanks to Opera receivers.

There are two options for enabling a new transmitter, even at a distance from the system:

- using a transmitter already programmed in the receiver, thanks to the enabling **Code exchange** between the two (figure 1);
- using the Nice O-Box connection interface; the receiver's **Certificate** is entered by just placing the new Era One next to the O-Box and following the guided procedure on a PC or PDA (figure 2).

**Safe,** if a transmitter is stolen or lost, with the O-Box the user can:

- **replace it,** maintaining the same functions as in the previous one, **disable** the old transmitter by increasing the priority level on the new Era One.

**Extremely practical:** using the O-Box software, the Era OneC version allows whole packs of 10 devices to be programmed in a single procedure, without even opening them!

**Elegant and convenient:** the Era One transmitter can be used as a stylish, high-tech keyring or fixed to the wall or your car's dashboard with the handy support included in the pack.

**Era OneFM, ideal for use in cities or places where many devices are present.**

868.46 MHz Rolling Code transmitter line, using frequency modulation (FM), less sensitive to interference than amplitude modulation AM.

## ERA ONE TRANSMITTERS

CODE	DESCRIPTION	PCS/PACK
<b>ON1E</b>	1 CHANNEL, 433.92 MHz	10
<b>ON2E</b>	2 CHANNELS, 433.92 MHz	10
<b>ON4E</b>	4 CHANNELS, 433.92 MHz	10
<b>ON9E</b>	9 CHANNELS, 433.92 MHz	10
<b>ON1CE</b>	1 CHANNEL, 433.92 MHz, WITH MULTIPLE INPUT SEQUENTIAL ENCODING	10
<b>ON2CE</b>	2 CHANNELS, 433.92 MHz, WITH MULTIPLE INPUT SEQUENTIAL ENCODING	10
<b>ON4CE</b>	4 CHANNELS, 433.92 MHz, WITH MULTIPLE INPUT SEQUENTIAL ENCODING	10
<b>ON1EFM</b>	1 CHANNEL, 868.46 MHz	10
<b>ON2EFM</b>	2 CHANNELS, 868.46 MHz	10
<b>ON4EFM</b>	4 CHANNELS, 868.46 MHz	10
<b>ON9EFM</b>	9 CHANNELS, 868.46 MHz	10

## TRANSMITTER TECHNICAL SPECIFICATIONS

	Carrier frequency	Estimated range	Encoding	Power supply	Battery life	Protection class	Dimensions Weight
<b>ON_E, ON_CE</b>	433.92 MHz	200 m (outdoor); 35 m (if inside buildings)*	O-Code 72 bit; rolling code	3 Vdc, type CR2032 lithium battery	2 years (with 10 transmissions per day)	IP40 (use in protected environments)	44x55x10 h mm 11 g
<b>ON_EFM</b>	868.46 MHz						

\* Transmitter range and receiver reception capacity may be affected by any devices operating on the same frequency in the area.

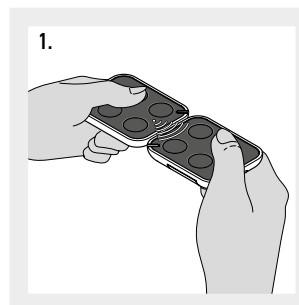

1. CODE EXCHANGE BETWEEN A MEMORIZED TRANSMITTER AND A NEW ONE, TO BE MEMORIZED.

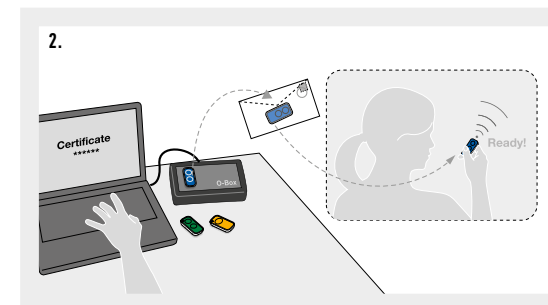

2. POSSIBLE MEMORISATION USING NICE O-BOX AND THE "CERTIFICATE".

# ERA FLOR

## 1, 2 and 4 channel transmitters with a new stylish design.

### 433.92 MHz rolling code system with self-learning function.

Also available in versions with multiple input sequential encoding (Era FlorCE).

**Absolute security:** rolling code transmission makes the transmitter impossible to clone.

**Ideal solution for the management of multi-user apartment block systems** thanks to the unique, personal code.

**Easy duplication of new transmitter close to the system** by using an authorised transmitter or directly using a key on the receiver, while a LED displays the various functions.



**Extremely practical:** using the O-Box programming unit, the Era Flor-CE version allows whole packs of 100 devices to be programmed in a single procedure, without even opening them.

The O-Box and dedicated software applications for PC and PDA allow:

- **quick, user-friendly programming** of receivers and transmitters;
- **management and printout of code list;**
- **creation of individual installation databases** (useful in multi-user systems).

### Optimal autonomy and low consumption.

**Elegant and convenient:** the Era Flor transmitter can be used as a stylish, high-tech keyring or fixed to the wall or your car's dashboard with the handy support included in the pack.

**Total compatibility** with previous Flor series receivers (universal, universal modular and with Nice or SM connector) and with the One receivers (OX1/OXIT, OX2/OX2T and OX4T).

## ERA FLOR TRANSMITTERS

CODE	DESCRIPTION	PCS/PACK
<b>FLO1RE</b>	1 CHANNEL ERA FLOR TRANSMITTER	10
<b>FLO2RE</b>	2 CHANNEL ERA FLOR TRANSMITTER	10
<b>FLO4RE</b>	4 CHANNEL ERA FLOR TRANSMITTER	10
<b>FLO1RCE</b>	1 CHANNEL ERA FLOR TRANSMITTER WITH MULTIPLE INPUT SEQUENTIAL ENCODING	10
<b>FLO2RCE</b>	2 CHANNEL ERA FLOR TRANSMITTER WITH MULTIPLE INPUT SEQUENTIAL ENCODING	10
<b>FLO4RCE</b>	4 CHANNEL ERA FLOR TRANSMITTER WITH MULTIPLE INPUT SEQUENTIAL ENCODING	10

## TRANSMITTERS TECHNICAL SPECIFICATIONS

Carrier frequency	Estimated range	Encoding	Power supply	Battery life	Protection class	Dimensions Weight
433.92 MHz	150/200 with tuned antenna in open spaces	52 bit digital (4.5 million billion combinations)	3 Vdc; lithium battery type CR2032	3 years (with 10 transmissions per day)	IP40 (use in protected environments)	58x86x22 h mm 55 g

\* Transmitter range and receiver reception capacity may be affected by any devices operating on the same frequency in the area.



FLO1RE



FLO2RE



FLO4RE

# NICEWAY

## Modular control system

to manage the range of Nice automations from any point within the home.

### Modular

The NiceWay system is based on a number of transmitter modules that can be placed in five different holder models to create a flexible range of made-to-measure solutions.

Although the modules, available from 1 to 80 groups or 240 channels, are very small in size, they are extremely easy to operate.

### Advanced and compatible

Frequency of 433.92 MHz, 52 Bit Rolling Code with (over 4.5 million of billion combinations); self-learning function.

Compatible with the 433.92 MHz Nice Ergo, Plano, FloR and VeryVR systems (Flo and Smilo with WM240C and WM080G).

Estimated range: 200 m in a free field, 35 m indoors.

Extended battery life (3 V lithium battery).

### All the NiceWay solutions

The 240 channel module with display, which controls 80 groups and 70 multi-groups, is ideal for the management of sophisticated systems. All the awnings, roller shutters and gates, as well as the office, home and hotel irrigation and lighting systems in just 14 g and 16 cm<sup>2</sup>!

### Made-to-measure

To protect the electronic parts from dirt and damp, the rubber function buttons are incorporated in the actual body of the control modules.

NiceWay can be used anywhere in the home, in the garage, the living room, the kitchen as well as the bathroom.

### Professional

For a more professional and practical use, the system can be programmed by means of the handy Nice palmtops.

## TECHNICAL SPECIFICATIONS











POWER SUPPLY (Vdc)	: 3 V WITH 1 LITHIUM BATTERY CR2032
BATTERY LIFE	: > 2 YEARS WITH 10 EVENTS/DAY
FREQUENCY	: 433.92 MHz ± 100 KHz
RADIATED POWER	: ESTIMATED AT APPROX. 1 mW
PROTECTION RATING (IP)	: 40
ESTIMATED RANGE	: 200 m IN A FREE FIELD, 35 m INDOORS
CODING	: 52 BIT ROLLING CODE
OPERATING TEMPERATURE (°C MIN. MAX.)	: -20 ÷ +55
DIMENSIONS (mm)	: 41x41x10
WEIGHT (g)	: 14

## The heart of the NiceWay system

The 1, 3, 6 and 9-channel modules for the control of single automations, groups or multi-groups: awnings, roller shutters, rolling doors, gates, industrial and garage doors, barrier gate operators, lighting and irrigation systems.



1. The transmitter module 2. The module holder cover 3. Wall or table shockproof holder 4. Table shockproof holder 5. Squared wall plate 6. Rectangular wall plate.

MODULE	CODE	DESCRIPTION	PC./PACK
<b>MODULES TO CONTROL STEP-BY-STEP AUTOMATION SYSTEMS</b>			
	<b>WM001C</b>	SINGLE CHANNEL MODULE TO CONTROL 1 AUTOMATION SYSTEM	10
	<b>WM003C</b>	THREE CHANNEL MODULE TO CONTROL 3 STEP-BY-STEP AUTOMATION SYSTEMS	1
	<b>WM009C</b>	NINE CHANNEL MODULE TO CONTROL 9 STEP-BY-STEP AUTOMATION SYSTEMS	1
Memorizing radio controls in Mode I: ON - OFF Mode II: ON/OFF - HOLD TO RUN - TIMER1 - TIMER2 (for the Screen products MOD0 II programming)			
<b>HYBRID MODULE TO CONTROL STEP-BY-STEP AND OPEN-STOP-CLOSE AUTOMATION SYSTEMS</b>			
	<b>WM003C1G</b>	MODULE TO CONTROL 3 STEP-BY-STEP AND 1 OPEN-STOP-CLOSE AUTOMATION SYSTEMS	1
<b>MODULES TO CONTROL OPEN-STOP-CLOSE AUTOMATION SYSTEMS</b>			
	<b>WM001G</b>	MODULE TO CONTROL 1 OPEN-STOP-CLOSE AUTOMATION SYSTEM EITHER INDIVIDUALLY OR IN MULTI-GROUP MODE	1
	<b>WM002G</b>	MODULE TO CONTROL 2 OPEN-STOP-CLOSE AUTOMATION SYSTEMS EITHER INDIVIDUALLY OR IN MULTI-GROUP MODE	1
	<b>WM003G</b>	MODULE TO CONTROL 3 OPEN-STOP-CLOSE AUTOMATION SYSTEMS EITHER INDIVIDUALLY OR IN MULTI-GROUP MODE	1
	<b>WM006G</b>	MODULE TO CONTROL 6 OPEN-STOP-CLOSE AUTOMATION SYSTEMS EITHER INDIVIDUALLY OR IN MULTI-GROUP MODE	1
	<b>WM004G</b>	MODULE TO CONTROL 4 OPEN-STOP-CLOSE AUTOMATION SYSTEMS EITHER INDIVIDUALLY OR IN MULTI-GROUP MODE AND SUN SENSOR ACTIVATION COMMAND	1
<b>MULTI-CHANNEL DISPLAY MODULE</b>			
	<b>WM080G</b>	MODULE TO CONTROL 80 OPEN-STOP-CLOSE AUTOMATION SYSTEMS EITHER INDIVIDUALLY OR IN MULTI-GROUP MODE AND SUN SENSOR ACTIVATION COMMAND	1
	<b>WM240C</b>	MODULE TO CONTROL 240 STEP-BY-STEP AUTOMATION SYSTEMS EITHER INDIVIDUALLY OR IN MULTI-GROUP MODE	1

## NICE DESIGN

Sophisticated shock-proof materials, immaculate finish, and essential design: wear, comfort and ease are guaranteed by the internationally renowned and prize-winning Nice design.

The choice of discreet or personalised solutions is vast thanks to the wide choice of colours and finishes.



FOR SWING GATES

FOR SLIDING GATES

BARRIER GATE OPERATOR SYSTEMS

FOR GARAGE AND INDUSTRIAL DOORS

CONTROL SYSTEMS AND ACCESSORIES

COMPATIBILITY TABLE AND ALPHABETICAL INDEX

# STONE

## NiceWay - Stone Portable and table-top supports.

### Fetching and practical

With Stone the radio control device becomes even more functional and catching.

In shock-proof rubber to completely protect the transmitting module, fully directional for greater reception, Stone is available in neutral or bright colours so as to perfectly blend into modern or elegant homes.

### Comfortable anywhere

Resistant to the most violent of shocks and garden humidity, Stone is always easy to find, be it on the living room or office coffee table, on the kitchen worktop, in the bathroom or on the side of the pool.



CODE	DESCRIPTION	PC/PACK
<b>WEW</b>	TABLE SHOCKPROOF HOLDER, WHITE	10
<b>WEO</b>	TABLE SHOCKPROOF HOLDER, ORANGE	10



**WEW**



**WEO**

# ONDO

## NiceWay - Ondo Portable, wall mounted and table-top supports.

### Portable, from table to wall

Ondo is the versatile NiceWay line support; the wall support with its simple magnetic fixing system, transforms Ondo from a comfortable portable transmitter to an inconspicuous wall plate.

Ondo, made in a shiny dirt-resistant plastic, has a rubber lower section to improve grip and prevent slipping when used on surfaces.

The transmitter module can be inserted so that Ondo can be used both in width and in length to increase the personalisation possibilities.



CODE	DESCRIPTION	PC/PACK
<b>WAX</b>	TABLE HOLDER, WHITE PLASTIC AND ICE BLUE RUBBER	10
<b>WWW</b>	MAGNETIC WALL SUPPORT FOR WAX	10



**WAX**



**WWW**



# OPLA

## NiceWay Wall plaques.

### Elegant, discreet and functional

Extremely slim - as is the plate itself - the transmitter inserted into the Opla wall plate permits to inconspicuously and fetchingly add additional control points without having to perform any building operations.

The NiceWay Opla wall plates are available in the square Opla-S version and the rectangular Opla-R version and in many different colours.



CODE	DESCRIPTION	PC/PACK
<b>WSW</b>	SQUARED WALL PLATE, WHITE	10
<b>WSB</b>	SQUARED WALL PLATE, BLACK	10
<b>WSA</b>	SQUARED WALL PLATE, ALUMINIUM	10
<b>WSG</b>	SQUARED WALL PLATE, GRAPHITE	10
<b>WST</b>	SQUARED WALL PLATE, NEUTRAL TRANSPARENT	10
<b>WSS</b>	SQUARED WALL PLATE, SEAWATER	10

CODE	DESCRIPTION	PC/PACK
<b>WRW</b>	RECTANGULAR WALL PLATE, WHITE	10
<b>WRB</b>	RECTANGULAR WALL PLATE, BLACK	10
<b>WRA</b>	RECTANGULAR WALL PLATE, ALUMINIUM	10
<b>WRG</b>	RECTANGULAR WALL PLATE, GRAPHITE	10
<b>WRT</b>	RECTANGULAR WALL PLATE, NEUTRAL TRANSPARENT	10
<b>WRS</b>	RECTANGULAR WALL PLATE, SEAWATER	10



WSW, WRW

WSB, WRB

WSA, WRA

WSG, WRG

WST, WRT

WSS, WRS

# GO

## NiceWay Mini cover.

### Go Nice!

Snugly in the pocket!

Every NiceWay transmitter really becomes portable with the Go support: the maximum performance to manage up to 240 channels from anywhere and with the maximum compactness.

Made of shock-proof rubber, in different and exclusive colours, Go protects the module from the most severe of knocks.

Go can be hung anywhere and can also be used as a key-ring thanks to the tie that is included in the pack.



CODE	DESCRIPTION	PC/PACK
<b>WCF</b>	MINI COVER, FERN GREEN	10
<b>WCG</b>	MINI COVER, GRAPHITE	10
<b>WCI</b>	MINI COVER, ICE BLUE	10
<b>WCO</b>	MINI COVER, ORANGE	10



WCF

WCG

WCI

WCO

FOR SWING GATES

FOR SLIDING GATES

BARRIER GATE  
OPERATOR SYSTEMS

FOR GARAGE  
AND INDUSTRIAL DOORS

CONTROL SYSTEMS  
AND ACCESSORIES

COMPATIBILITY TABLE  
AND ALPHABETICAL INDEX

# RECEIVERS

## ERA INTI, ONE, FLOR, NICEWAY

### The complete line of receivers with Opera system functions, suitable for all installation requirements:

- **with connector**, compatible with latest-generation Nice control units with SM port;
- **universal prewired**, for use with all types of control unit, for the control of any automation, lighting or irrigation system or other electric circuits.

#### Maximum flexibility:

up to 1024 transmitters can be memorised.

#### Convenient and practical:

the inclusion of a transmitter in the OXIT/OXITFM, OX2T/OX2TFM and OX4T receivers allows radio codes to be accessed by means of the O-Box multifunction interface even when in inaccessible positions (figure 3).

OXIT/OXITFM, OX2T/OX2TFM and OX4T receivers can be used as signal repeaters to increase the operating distance between transmitters and other One series receivers (figure 4).

**Secure use**, thanks to the 3 password-protected levels.

The **O-Box** and dedicated software applications for PC and PDA allow:

- **quick, user-friendly programming** of receivers and transmitters;
- **management and printout of code list**;
- creation of **individual installation databases** (useful in multi-user systems).

### SM plug-in receiver with Flor system functions, step-by-step and anti-burglar functions.

**Management of multi-user system** through the unique, personal code: the recognition receivers can receive and memorise up to 255 codes.

**Memorisation:** a particular receiver output can be associated to each transmitter key (e.g. key 3 TX= output 1 RX).

### 433.92 MHz RECEIVERS, WITH OPERA SYSTEM FUNCTIONS

#### WITH CONNECTOR

CODE	DESCRIPTION	PCS/PACK
OXI	4 CHANNELS, WITHOUT BUILT-IN TRANSMITTER	1
OXIT	4 CHANNELS, WITH BUILT-IN TRANSMITTER	1

#### PRE-WIRED UNIVERSAL

OX2	2 CHANNELS, WITHOUT BUILT-IN TRANSMITTER	1
OX2T	2 CHANNELS, WITH BUILT-IN TRANSMITTER	1
OX4T	4 CHANNELS, WITH BUILT-IN TRANSMITTER	1



OXI, OXIT



OX2, OX2T



OX4T  
See page 177

### 868.46 MHz RECEIVERS, WITH OPERA SYSTEM FUNCTIONS

#### WITH CONNECTOR

CODE	DESCRIPTION	PCS/PACK
OXIFM	4 CHANNELS, WITHOUT BUILT-IN TRANSMITTER	1
OXITFM	4 CHANNELS, WITH BUILT-IN TRANSMITTER	1

#### PRE-WIRED

OX2FM	2 CHANNELS, WITHOUT BUILT-IN TRANSMITTER	1
OX2TFM	2 CHANNELS, WITH BUILT-IN TRANSMITTER	1



OXIFM, OXITFM



OX2FM, OX2TFM

### 433,92 MHz RECEIVERS, WITH FLOR SYSTEM FUNCTIONS

#### WITH SM PLUG-IN

CODE	DESCRIPTION	PCS/PACK
SMXI	UP TO 4 CHANNELS WITH 256-CODES MEMORY	1

#### Professional, tuned directional aerial

ABF	BRACKET MOUNTED	1
-----	-----------------	---

## MULTI-FUNCTION INTERFACE

CODE	DESCRIPTION	PCS/PACK
<b>0BOX2</b>	DUAL BAND INTERFACE, FOR 433.92/868.46 MHz DEVICES, COMPLETE WITH SOFTWARE, SUPPLIED WITH USB CONNECTION CABLE.	1
<b>0BOX2B</b>	DUAL BAND INTERFACE, FOR 433.92/868.46 MHz DEVICES, COMPLETE WITH SOFTWARE, WITH USB CONNECTION CABLE AND BUILT-IN BLUETOOTH MODULE.	1



**0-BOX**

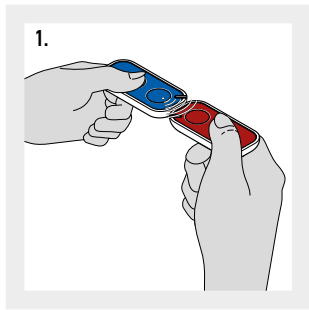

1. CODE EXCHANGE BETWEEN A MEMORIZED TRANSMITTER AND A NEW ONE, TO BE MEMORIZED.

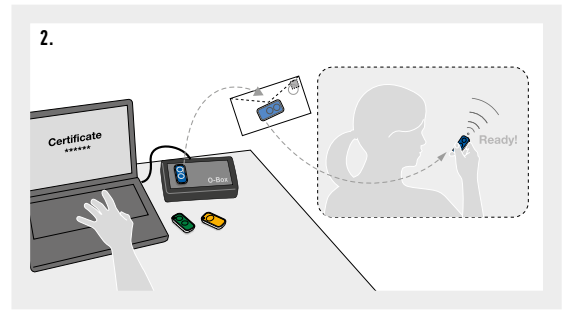

2. POSSIBLE MEMORISATION USING NICE O-BOX AND THE "CERTIFICATE".

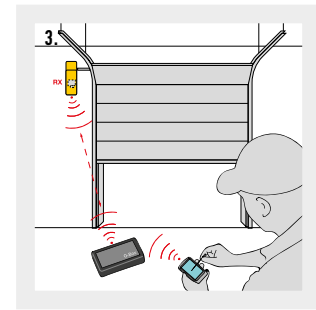

3. THE PRESENCE OF A "TRANSMITTER" IN THE OXIT, OX2T AND OX4T RECEIVERS ALLOWS RADIO CODES TO BE ACCESSED BY MEANS OF THE O-BOX MULTIFUNCTION INTERFACE.

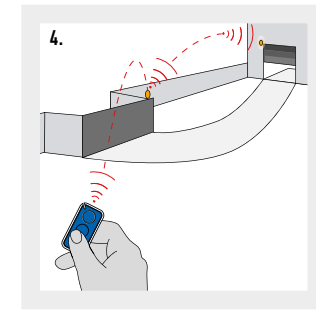

4. OXIT, OX2T AND OX4T RECEIVERS CAN BE USED AS SIGNAL REPEATERS.

## RECEIVER WITH OPERA SYSTEM - TECHNICAL SPECIFICATIONS

	Reception frequency (MHz)	Transmission frequency (MHz)	Input impedance (Ohm)	Sensitivity	Encoding	Number of channels	Relay contact	Power supply	Absorption	Protection class	Dimensions Weight	
<b>OXI</b>	433.92	-	52	>0.5 $\mu$ V for signals with successful outcomes	O-Code, FloR, Flo	4 (15 on BUS T4)	-	5 Vdc	30 mA (max)	IP 30	50x19x45 h mm, 20 g	
<b>OXIT</b>		433.92				2	max 0.5 A 50 V (NA)	from 12 to 28 Vdc/Vac	80 mA (max) with relays active			
<b>OX2</b>		-				433.92	4 relays with NO and NC contacts, voltage-free	5 A - 250 V	110 - 240 Vac 50/60 Hz	80 mA	IP 44 (with container intact)	128x112x43 h mm, 260 g
<b>OX2T</b>												
<b>OX4T</b>												
<b>OXIFM</b>	868.46	-	52	>0.8 $\mu$ V for signals with successful outcomes	O-Code	4 (15 on BUS T4)	-	5 Vdc	30 mA (max)	IP 30	50x19x45 h mm, 20 g	
<b>OXITFM</b>		868.46				2	max 0.5 A 50 V (NA)	from 12 to 28 Vdc/Vac	100 mA (max) with relays active			
<b>OX2FM</b>		-				868.46	4 relays with NO and NC contacts, voltage-free	5 A - 250 V	110 - 240 Vac 50/60 Hz	80 mA	IP 44 (with container intact)	128x112x43 h mm, 260 g
<b>OX2TFM</b>												

## RECEIVER WITH FLOR SYSTEM - TECHNICAL SPECIFICATIONS

	Reception frequency (MHz)	Input impedance (Ohm)	Sensitivity	Power supply	Absor. when quiescent	Decoding	Number of channels	Relay contact	Dimensions (mm)
<b>SMXI</b>	433.92 quartz controlled	52	> 0.5 $\mu$ V for signals with successful outcomes	5 Vdc	-	52 digital bits (4.5 million billion comb.)	4	-	50x18x46 h

## ACCESSORIES - TECHNICAL SPECIFICATIONS

	Reception frequency (MHz)	Impedance (Ohm)	Bracket	Cablec
<b>ABF</b>	433,92	50	stainless steel	RG 58

# OPERA

## Opera Control, advanced management of automation systems also at a distance.

The innovative Opera system enables the installer to manage, program and control automation systems, also remotely, simply and safely, with significant savings in time.

The **Opera** system comprises transmitters and **One** series receivers, the O-Box connection interface and the communication **software "O-View Software Suite"** and **"O-Box Software Suite"**.

All components communicate via **BUS T4** or the new **O-Code** Rolling Code system, making transmissions safer and reducing automation response times.

**Nice Opera** simplifies the installer's work, making for easier programming, and enabling access to all control panel parameters to adapt the system to all requirements. No specific procedures needed for each product: single programming mode with intuitive menus, with no need to consult instructions.

**Constantly efficient assistance for all customers:** Simplifies system programming by means of the O-View multifunction display which when connected directly to the control panels compatible with the Opera system via BUS T4, enables full access to the system functions, for practical, rapid and advanced programming.

**BUS T4** is the innovative communication protocol that enables you to create extensive networks of compatible automation systems, managing them from a single point via O-View.

Device management can be protected by two password levels. By interfacing the system with the PC, you can control a complex automation system such as those found in densely frequented buildings (hospitals, hotels, companies, etc.).

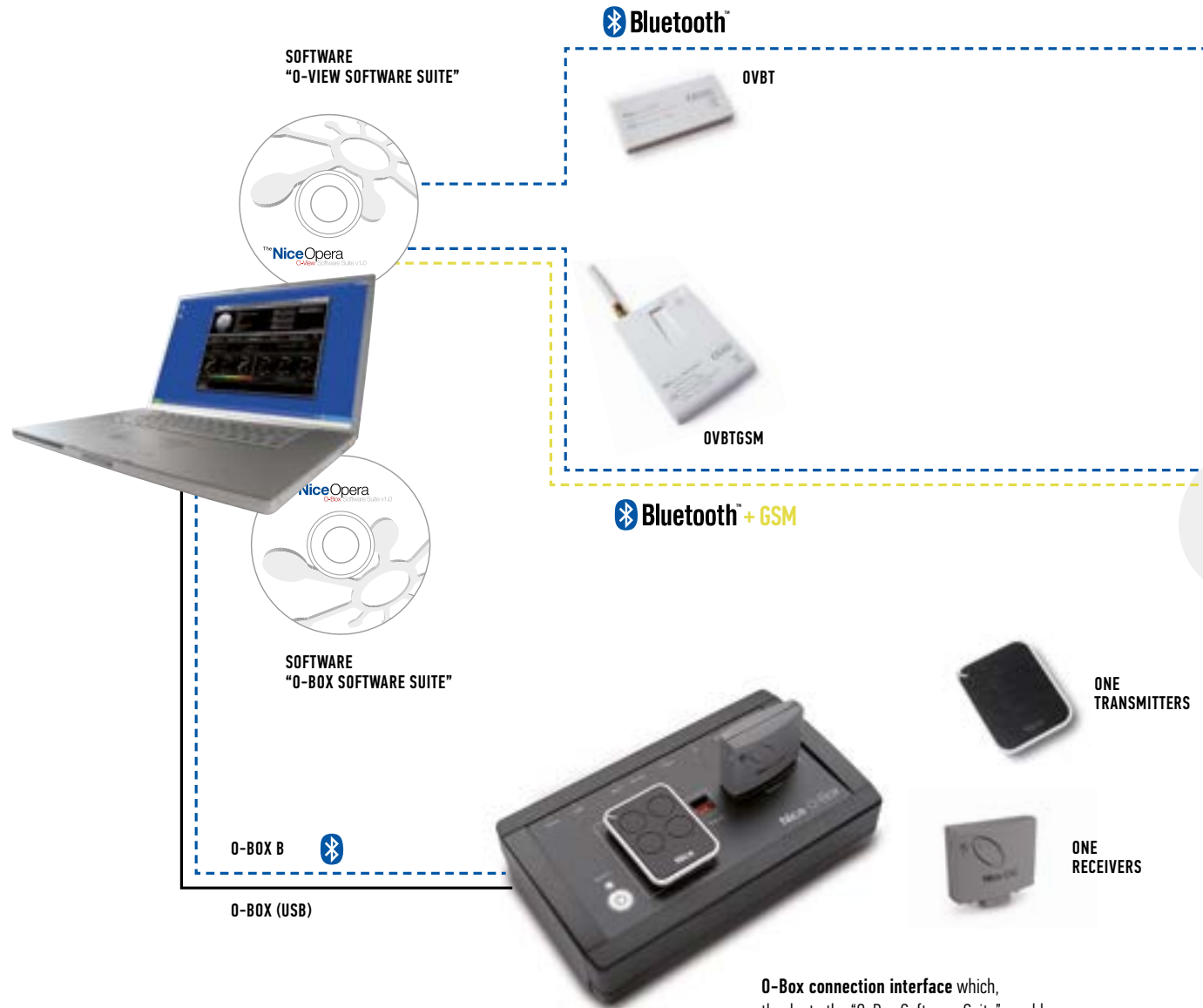

**O-Box connection interface** which, thanks to the "O-Box Software Suite", enables the configuration and programming of all Nice control devices, from the PC or PDA.



<<< **BUS T4**

**O-View, multifunction display**  
 Unit for control, programming and diagnostics for devices equipped with BUS T4 connection, on site or remotely via GPRS thanks to the connection with your PDA, Smartphone or PC.

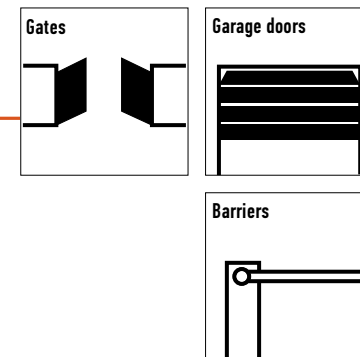

FOR SWING GATES

FOR SLIDING GATES

BARRIER GATE OPERATOR SYSTEMS

<<< **BUS T4**

**OX4T universal 4-channel receiver** with built-in transmitter. For remote control of any automation, irrigation and lighting systems or other electrical circuits.



for Nice Motors not designed for

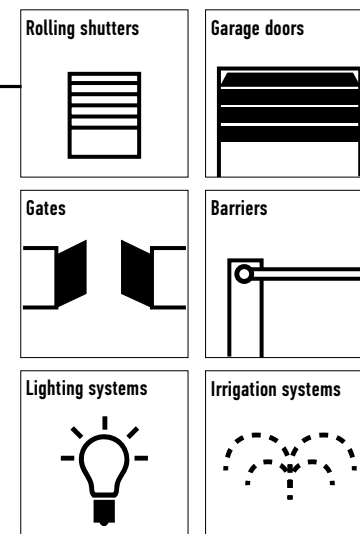

FOR GARAGE AND INDUSTRIAL DOORS

CONTROL SYSTEMS AND ACCESSORIES

COMPATIBILITY TABLE AND ALPHABETICAL INDEX

Opera

# O-VIEW

OPERA

**Unit for control, programming and diagnostics for devices equipped with BUS T4 connection, on site or remotely via GPRS thanks to the connection with your PDA, Smartphone or PC.**

**Advanced management:** O-View is connected directly to the compatible control unit via a BUS T4 cable (supplied). By connecting O-View permanently to a control unit or group of control units via BUS T4, a network can be created for local or remote centralised management.

**Simple programming mode** with intuitive menus valid for each product, with no need to consult the specific instructions.

O-View powers up and automatically recognises all devices on the network as soon as it is connected, displaying only the specific parameters of the device on which to intervene.

In the case of several devices on the network the BUS T4 address is identifiable by means of a text label personalised as required, enabling rapid recognition of the associated device.

**Programmable:** thanks to the built-in clock, it is also possible (with integrated backup battery) to program delivery of commands at a set time, for example to automate opening and closing of complex industrial and commercial systems or for the creation of "scenarios".

A practical wall-mounted support supplied.

**Safe:** two password-protected levels (for the user and the installer).

**Practical:** O-View is your portable office, and can be connected just when programming or for maintenance, or can be installed permanently on site to exploit all the benefits of local or remote centralised management.



OVB T

OVB T GSM

O-VIEW SOFTWARE SUITE

CODE	DESCRIPTION	PC./PACK
<b>OVIEW</b>	UNIT FOR CONTROL, PROGRAMMING AND DIAGNOSTICS OF DEVICES EQUIPPED WITH BUS T4 CONNECTION	1
<b>OVB T</b>	BLUETOOTH MODULE FOR O-VIEW AND "O-VIEW SOFTWARE SUITE" APPLICATION FOR PC, PDA OR SMARTPHONE	1
<b>OVB T GSM</b>	GSM MODULE FOR O-VIEW AND "O-VIEW SOFTWARE SUITE" APPLICATION FOR PC, PDA OR SMARTPHONE	1

## TECHNICAL SPECIFICATIONS

GRAPHIC INTERFACE	: LCD DISPLAY 128x64 DOTS (46x29 mm); 2.2"
OPERATOR INPUT DEVICE	: JOYPAD WITH 5 + 2 KEYS
DISPLAY/KEY LIGHTING	: WHITE LIGHT
TIME AND DATE DISPLAY	: WITH BACKUP BATTERY (MIN. LIFETIME 10 YEARS)
MAXIMUM NUMBER OF COMMANDS PER HOUR	: 64
EVENT LOG	: STORAGE CAPACITY 400 EVENTS
CONNECTION CABLE LENGTH (m)	: 2 (CABLE SUPPLIED); 700 (OTHER CABLE)
POWER SUPPLY	: SUPPLIED BY DEVICES ON BUS T4 NETWORK
ABSORBED CURRENT (mA)	: MAX. 20 (WITHOUT ACCESSORIES)
INSULATION	: CLASS III
HOUSING PROTECTION RATING (IP)	: 20
WORKING TEMP. (°C MIN/MAX)	: FROM -20° TO +55°
DIMENSIONS (mm)	: 107x61x20 h (WITH WALL-MOUNTED SUPPORT: 125x70x32 h)
WEIGHT (g)	: 75 (WITHOUT CABLE)

## ACCESSORIES

CODE	DESCRIPTION	PC./PACK
<b>OVA 1</b>	CLAMP FOR FITTING CONNECTORS RJ14	1
<b>OVA 2</b>	CONNECTORS RJ14, TYPE 6/4, FOR FLAT 4-WIRE CABLE	5
<b>OVA 3</b>	RJ14 SPLITTERS, TYPE 6/4, FOR CASCADE CONNECTION OF DEVICES ON BUS T4 NETWORK	5
<b>OVA 4</b>	FLAT 4-WIRE CABLE FOR CONNECTION OF DEVICES ON BUS T4 NETWORK, LENGTH 100 m	1



OVA 1

OVA 2

OVA 3

OVA 4

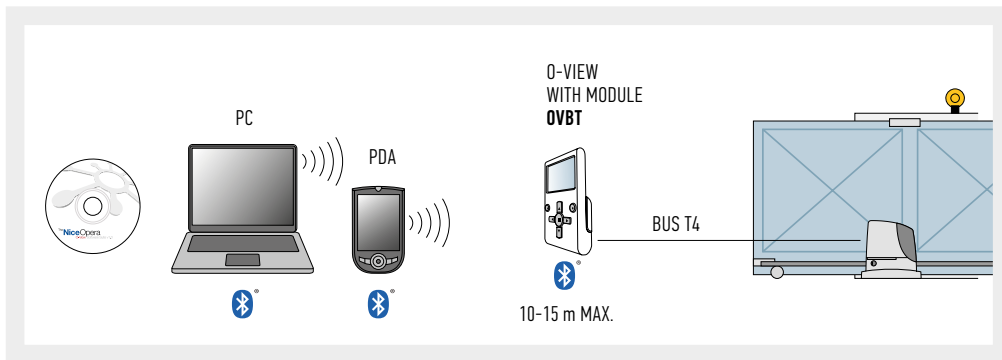

**OVBT**  
**Bluetooth connection module for O-View interface.**  
 "O-View Software Suite" enables connection via PC or PDA to O-View in the vicinity of the system, to intervene on the control units on the BUS T4 network. Maximum connection distance 15 m.

#### O-VIEW SOFTWARE SUITE

This application, supplied with OVBT and OVBTGSM, as well as expanding the functions of O-View enables the creation of a database of installations with personal data of clients and configurations of each system, even on more complex versions.

There are two versions of software: "O-View Desktop" designed for installation on a PC and "O-View Mobile" which enables use of the functions of the desktop version on a smaller screen of a PDA or Smartphone.

**By connecting to the site [www.nice-service.com](http://www.nice-service.com) users can download the constantly updated firmware and software versions.**

The interface of "O-View Software Suite" has been specially designed to enable rapid access to all parameters of the connected devices without the need for physical access, as well as quick diagnostics of malfunctions by consulting the event log, all the most practical and intuitive way possible.

The O-View control function has been expanded: in just one PC screen, all applications connected via BUS T4 can be controlled.

#### Minimum requirements

- O-View Mobile version for PDA palmtop:**
- Processor: (300 MHz) Recommended by Nice: (> 300 MHz)
  - RAM: 64 MB Recommended by Nice: 128 MB
  - Storage memory: 5 MB Recommended by Nice: 20 MB
  - Operating system: Windows® Mobile 2003 Recommended by Nice: Windows® 5.0
  - Connection: Bluetooth®
  - Graphics resolution: 240 x 320, 256 colours
  - PC with: CD-Rom (required for software installation on palmtop).

- O-View Desktop version for PC:**
- Processor: type AMD®/Intel® (500 MHz) Recommended by Nice: type AMD®/Intel® (1 GHz)
  - RAM: 128 MB Recommended by Nice: 256 MB
  - Free space on disk: 280 MB Recommended by Nice: 512 MB
  - Operating system: Windows® 98 SE or later Recommended by Nice: Windows® 2000 or later up to Win 7
  - Connection: Bluetooth®
  - Graphics resolution: 800 x 600, 256 colours
  - Disk drive: CD-Rom (required for installation).

Note – software installation includes installation of the program Microsoft® .NET Framework Redistributable 2.0.

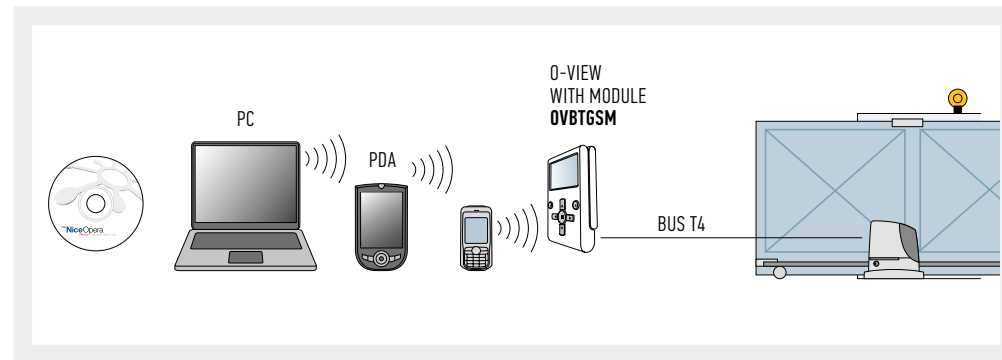

**OVBTGSM**  
 In addition to the benefits of the OVBT module, the automation or network of automations can now be **controlled via GSM** by connecting O-View to the system via BUS T4.

A GPRS connection also enables connection via the Internet to O-View to obtain all management functions offered by the software from any location with no need for presence on site.

The user can remotely control the automation via GSM, from any of the enabled numbers, and check status, such as opening a gate by means of a phone call or by sending 4 different controls via SMS text message, with the security offered by entry of a unique password.

**INB, the Nice control interface** that enables communication between the systems Nice Bus (TTBus and BusT4) and MyHome of BTicino (SCS).



CODE	DESCRIPTION	PC/PACK
INB	COMMUNICATION INTERFACE BETWEEN BTICINO BUS (SCS) AND NICE BUS (TTBUS AND BUST4)	1

#### TECHNICAL SPECIFICATIONS

	Power supply	Consumption	Insulation	Protection rating (IP)	Working temp. (°C Min. Max)	Dimensions (mm)
INB	to BusT4, or 24 Vac/dc (limits 20 ÷ 35 Vdc, 22 ÷ 35 Vac)	approx. 18 mA	class III	20	-20+50 °C	41x52x18h

# O-BOX

OPERA

**O-Box is the multi-function interface** which, thanks to the dedicated software "**O-Box Software Suite**", enables **the configuration and programming directly from the PC or PDA**, practically and intuitively, **all transmitters, receivers and other Nice control devices.**

### The convenience of remote control:

O-Box enables a number of tasks to be performed directly from the office, **without the need to visit the client's system.** For example the operator can program the functions and parameters of transmitters with the utmost of ease, and send them already configured and operative to the clients.



### It is also possible to:

- program transmitters in the One series via radio;
- manage all functions via radio of the receivers in the One series fitted with built-in transmitter;
- read and write transponder badges in the Moon series;
- receive data via radio from transmitters in the series Smilo, VeryVE, Flo, VeryVR, FloR, One, Niceway or via optical reader for transmitters in the Bio series;
- program receivers in the series Smilo, Bio, FloR and One and memories of the control devices MOMB, MOTB and MORX;
- create and manage an updated database with personal data of clients and configurations of the receivers installed in the respective systems.

O-Box interfaces with your PC or PDA palmtop, performing the control, entry, deletion, enabling or disabling of codes, programming of the memory, functions and typical parameters of the receivers, transmitters and other Nice control devices.

### The software "O-Box Software Suite"

can be installed quickly and easily either on PC (O-Box Desktop version) or on PDA palmtop (O-Box Mobile version).

**Universal:** O-Box manages all programming procedures possible by means of BUPC.

It also enables import of databases previously created using the software for BUPC.

CODE	DESCRIPTION	PC./PACK
<b>OBOX2</b>	MULTIPURPOSE INTERFACE COMPLETE WITH SOFTWARE "O-BOX SOFTWARE SUITE" WITH USB CONNECTION CABLE SUPPLIED. DUAL BAND, FOR DEVICES AT 433.92/868.46 MHz	1
<b>OBOX2B</b>	MULTIPURPOSE INTERFACE COMPLETE WITH SOFTWARE "O-BOX SOFTWARE SUITE" WITH USB CONNECTION CABLE AND INTEGRATED BLUETOOTH MODULE. DUAL BAND, FOR DEVICES AT 433.92/868.46 MHz	1

### TECHNICAL SPECIFICATIONS

CODE	OBOX2	OBOX2B
FREQUENCY RECEPTION (MHz)	433.92/868.46	
ESTIMATED RANGE (m)	10	
COMMUNICATION WITH WINDOWS	USB, RS232	BLUETOOTH, USB, RS232
COMMUNICATION WITH WINDOWS MOBILE	BLUETOOTH	
WORKING TEMP. (°C MIN/MAX)	-20 : +55	
DIMENSIONS (mm)	195x116x48	
WEIGHT (g)	412	418

### ACCESSORIES

CODE	DESCRIPTION	PC./PACK
<b>ALA1</b>	BATTERY CHARGER POWER SUPPLY UNIT	1
<b>CABLA01</b>	CABLE FOR CONNECTING O-BOX TO THE COMPUTER VIA THE RS232 PORT	1
<b>CABLA02</b>	OPTICAL READER FOR PROGRAMMING TRANSMITTERS IN THE SERIES "BIO" AND "FLOR"	1
<b>CABLA03</b>	CABLE FOR CLONING TRANSMITTERS IN THE SERIES "VERY"	1
<b>CABLA04</b>	CABLE FOR CLONING TRANSMITTERS IN THE SERIES "BIO" AND "FLOR"	1
<b>CABLA05</b>	CABLE FOR PROGRAMMING TUBULAR MOTORS FOR AWNINGS AND SHUTTERS, EQUIPPED WITH PORT TTBUS	1
<b>CABLA06</b>	CABLE FOR PROGRAMMING RECEIVERS UNIVERSAL IN THE SERIES "SMX" AND "OX"	1
<b>CABLA07</b>	CABLE FOR CLONING TRANSMITTERS IN THE SERIES "ERGO" AND "PLANO"	1
<b>CABLA09</b>	CABLE FOR CLONING TRANSMITTERS IN THE SERIES "ERA-FLOR"	1

### NOTE ON CABLA ACCESSORIES:

O-Box is only supplied with the USB cable; all other cables are optional and are not supplied in the pack.

### Minimum software installation requirements

#### O-Box Mobile version for PDA palmtop:

- Processor: (300 MHz) Recommended by Nice: (> 300 MHz)
- RAM: 64 MB Recommended by Nice: 128 MB
- Storage memory: 5 MB Recommended by Nice: 20 MB
- Operating system: Windows® Mobile 2003 Recommended by Nice: Windows® 5.0
- Connection: Bluetooth®
- Graphics resolution: 240 x 320, 256 colours
- PC with: CD-Rom (required for software installation on palmtop).

#### O-Box Desktop version for PC:

- Processor: type AMD®/Intel® (500 MHz) Recommended by Nice: type AMD®/Intel® (1 GHz)
- RAM: 128 MB Recommended by Nice: 256 MB
- Free space on disk: 280 MB Recommended by Nice: 512 MB
- Operating system: Windows® 98 SE or later Recommended by Nice: Windows® 2000 or later up to Win 9
- Connection: Bluetooth®
- Graphics resolution: 800 x 600, 256 colours
- Disk drive: CD-Rom (required for installation).

Note - software installation includes installation of the program Microsoft®.NET Framework Redistributable 2.0.



# OX4T

OPERA

## Universal 4-channel receiver in the One series, with built-in transmitter.

For remote control of any automation on gates, garage doors, road barriers, shutters, awnings, venetian blinds, irrigation and lighting systems or other electrical circuits.

## Equipped with BUS T4 connector for connection to O-View.

### An extended system:

OX4T manages 4 outputs controlled by 4 relays, usable as power relays or voltage-free contacts, to extend use of the Opera system also to devices with specific provisions.

Thanks to the internal transmitter, OX4T can be used as a repeater, thereby increasing the operating range between transmitters and other receivers in the One series.



### Practical and functional:

OX4T can be connected via radio to the interface O-Box and via BUS T4 to the multifunction display O-View, to enable programming, diagnostics, timed functions and management of codes, also remotely by means of the modules OVBT and OVBTGSM.

### 2 programming modes:

"Mode I" and the new "extended Mode II" which enables expansion of the number of controls to up to 14.

**Multicode:** OX4T is also compatible with the transmitters with encoding system O-code, Smilo, Flo, FloR, FloR and TTS.

OX4T is fitted with removable terminals to facilitate connections and a generously sized memory to enable storage of up to 1024 transmitters, with the option for password protection.

CODE	DESCRIPTION	PC./PACK
<b>OX4T</b>	UNIVERSAL 4-CHANNEL RECEIVER WITH BUILT-IN TRANSMITTER	1

### TECHNICAL SPECIFICATIONS

POWER SUPPLY (Vac 50/60 Hz)	: 110 ± 240
MAXIMUM ABSORBED CURRENT (mA)	: 80
ENCODING	: 0-CODE / TTS / FLOR (ROLLING CODE); OR SMILO (ROLLING CODE) OR FLO
FREQUENCY (MHz)	: 433.92
ANTENNA IMPEDANCE (Ohm)	: MORE THAN 0.5 FOR SUCCESSFUL SIGNAL
ESTIMATED RANGE (m)	: 200 IN OPEN SPACES 35 IF INSIDE BUILDINGS
RADIATED POWER (Dbm)	: +2
MAX. CAPACITY OF TRANSMITTER MEMORY	: 1024 (MAXIMUM)
OUTPUTS	: 4 RELAYS WITH NO AND NC CONTACTS, VOLTAGE-FREE
CONTACT CAPACITY	: 5 A - 250 V
TIMER TIMES	: PROGRAMMABLE FROM 2 SECONDS TO 540 MINUTES
PROTECTION RATING (IP)	: 44 (WITH CONTAINER INTACT)
WORKING TEMP. (°C MIN/MAX)	: FROM -20° TO +55°
DIMENSIONS (mm)	: 128X112X43 H
WEIGHT (g)	: 260

### ACCESSORIES

CODE	DESCRIPTION	PC./PACK
<b>OVA1</b>	CLAMP FOR FITTING CONNECTORS RJ14	1
<b>OVA2</b>	CONNECTORS RJ14, TYPE 6/4, FOR FLAT 4-WIRE CABLE	10
<b>OVA3</b>	RJ14 SPLITTERS, TYPE 6/4, FOR CASCADE CONNECTION OF DEVICES ON BUS T4 NETWORK	5
<b>OVA4</b>	FLAT 4-WIRE CABLE FOR CONNECTION OF DEVICES ON BUS T4 NETWORK, LENGTH 100 m	1



OVA1



OVA2



OVA3



OVA4

FOR SWING GATES

FOR SLIDING GATES

BARRIER GATE  
OPERATOR SYSTEMS

FOR GARAGE  
AND INDUSTRIAL DOORS

CONTROL SYSTEMS  
AND ACCESSORIES

COMPATIBILITY TABLE  
AND ALPHABETICAL INDEX

# TAG SYSTEM

## Ideal for restorations and upgrades of existing systems.

The Tag system, disappearing inside standard wall mounted plates and suitable to confined spaces, are ideal for restorations and upgrades of existing systems to control home automations, lighting points and all loads up to 500 W not directly accessible from cable controls.

All without the need to replace the existing system or involve building work!

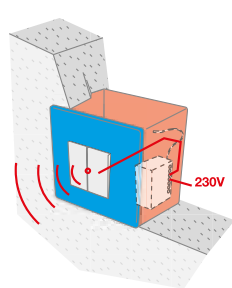

1

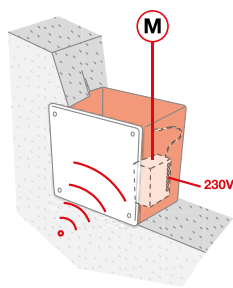

2

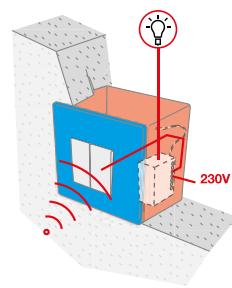

3

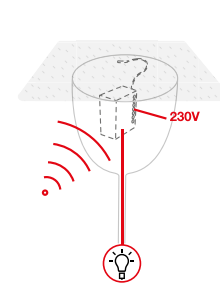

4

**1. TTX4: recessed transmitter** with mains power supply. Ideal for the control of automations not directly accessible from cable controls.

**2. TT2N: miniaturised control unit** for control of a 230 Vac motor up to 500 W, with built-in radio receiver.

**3. TT2L: miniaturised control unit** for control of lighting systems, with built-in radio receiver.

**4. TT2D: miniaturised control unit** for control of lighting systems from multiple points, with built-in radio receiver and switch.



### Invisible, but highly effective

Since miniaturised control units are incorporated invisibly into ordinary wall plates, they allow quick and easy installation and unbeatable safe, precise connection with all system components. Extremely compact size.



### Perfect for every home

Ideal in renovation projects and when upgrading existing systems to control home automations, all with no need to replace the existing system or do any building works! What could be more discreet? It's Nice!



### Comfort and simplicity always

Tag system coupled to the transmitter range. With just a simple touch, NiceWay module allows the wireless control of awnings and shutters, automation, irrigation and lighting systems and all loads up to 1,000W/500 VA not accessible by cable and, what's more, offers the option of wire connecting the miniaturized control unit to the existing wall switch in order to get an additional control point.

## TTX4, TTXB4

TTX4, with mains power supply and TTXB4, with long battery life power.

Optional connection of up to 4 pushbuttons for cable control of automations.

### Recessed transmitter ideal for the control of automations not directly accessible from cable controls.

433.92 MHz frequency, with 52 bit rolling code (over 4.5 million of billion combinations).

CODE	DESCRIPTION	PC/PACK
TTX4	RECESSED TRANSMITTER, 4 CHANNELS, WITH MAINS POWER	1
TTXB4	RECESSED TRANSMITTER, 4 CHANNELS, WITH LONG BATTERY LIFE POWER	1

### TECHNICAL SPECIFICATIONS

CODE	TTX4	TTXB4
POWER SUPPLY	120 or 230 Vac, 50/60 Hz; (limits 100 ÷ 255 V)	3 Vdc; lithium battery type CR2032
CARRIER FREQUENCY	433,92 MHz ± 100 KHz	
ESTIMATED RANGE	35 m INDOORS	
CODING	52 BIT DIGITAL (4.5 MILLION BILLION COMBINATIONS)	
PROTECTION RATING (IP)	20	
WORKING TEMP. (°C MIN/MAX)	-20° ÷ +55°	
DIMENSIONS (mm)	18x33x40 h	



# TT2

**Mindy TT miniaturised control units**, totally compatible with the Nice transmitters in the series Era, NiceWay, Flo, Very, Planotime, FloR and Smilo.

**Maximum flexibility:** can memorise up to 30 transmitters in Mode I and Mode II.

**Fast programming** thanks to the programming button. An indicator LED helps the user to follow the correct programming procedure, for example signalling when the set thresholds of the climatic sensor are exceeded.

**Possibility of connection** to climatic sensors Nemo and Volo S-Radio.

**IP20 protection level.**

**TT2N, control unit for 230 Vac motor up to 500 W, with built-in radio receiver.**

Possibility of connecting a pushbutton for cable control in mode STEP-BY-STEP - ALWAYS UP - ALWAYS DOWN.

Possibility of memorizing radio controls in Mode I: UP - STOP - DOWN - "HOLD-TO-RUN" DOWN  
Mode II: STEP-BY-STEP - UP STOP - DOWN STOP - STOP - "HOLD-TO-RUN" DOWN - "HOLD-TO-RUN" UP.

**TT2L, control unit for lighting systems, with built-in radio receiver.**

For the control of 230 Vac mains voltage loads with power up to 1000 W / 500 VA.

Simplified connections thanks to the switch connected directly to the power mains (not for TT2D).

Possibility of connecting a switch for cable control in ON/OFF mode.

Possibility of memorizing radio controls in Mode I: ON - OFF  
Mode II: ON/OFF - HOLD TO RUN - TIMER1 - TIMER2.

Connection to climatic sensor Volo S-Radio enables management of light activation and shutdown by means of the "Sun" sensor.

Programmable timer from a minimum of 0.5" to a maximum of approx. 9 hours; optimised programming procedure, maintaining set values also in the event of a power failure.

**TT2D, control unit for lighting systems from multiple points, with built-in radio receiver and switch.**

Same characteristics as TT2L.



TT2N

CODE	DESCRIPTION	PC/PACK
TT2N	CONTROL UNIT FOR 230 Vac MOTOR WITH BUILT-IN RADIO RECEIVER	1
TT2L	CONTROL UNIT FOR MANAGEMENT OF 230 Vac LIGHTING SYSTEMS, WITH BUILT-IN RADIO RECEIVER	1
TT2D	CONTROL UNIT FOR MANAGEMENT OF 230 Vac LIGHTING SYSTEMS, WITH BUILT-IN RADIO RECEIVER AND SWITCHING MODULE	1

## TECHNICAL SPECIFICATIONS

CODE	TT2N	TT2D	TT2L
POWER SUPPLY (Vac/Hz)	120 0 230 Vac, 50/60 Hz, LIMITS: 100÷255 Vac		
FREQUENCY (MHz)	433.92		
FOR TRANSMITTERS IN THE SERIES	ERA, NICEWAY, FLOR-S, FLO, VERYVE, VERYVR, SMILO		
MAXIMUM MOTOR POWER	500VA FOR VN = 230V, 600VA FOR VN = 120V	1000W/500VA FOR VN = 230V, 600W/600VA FOR VN = 120V	
PROTECTION RATING (IP)	20		
MANOEUVRE DURATION (SEC)	4÷240 S (FACTORY SETTING APPROX. 150 S)	1 S÷9 H (FACTORY SETTING TIMER1=1 MIN, TIMER2=10 MIN)	
WORKING TEMP. (°C MIN/MAX)	-20 ÷ +55		
DIMENSIONS (mm)	40x18x32		
WEIGHT (g)	20		



TT2L



TT2D

# TT1

## Mindy TT1 miniaturised control units with pass-through installation, IP55 protection,

With radio-controls 433.92 MHz receiver with over 4.5 million billion combinations.

Self-recognition of the transmitters of the Era, NiceWay, Flo, Very, Planotime, FloR and Smilo series.

### TT1N for awnings and rolling-shutters.

For motors max. 500 W.

Total flexibility of motor control with 2 transmitter memorisation modes

Mode I: UP - STOP - DOWN

Mode II: STEP-BY-STEP - ASCENT ONLY - DESCENT ONLY - STOP.

Memorizes up to 30 transmitters.

Internal terminal board for connection.

Manages the new climatic sensors Nemo and Volo S-Radio for synchronised controls.

The work time can be programmed from a minimum of 4" to a maximum of 4'.

### TT1L for lighting systems, irrigation pumps, etc...

For controlling loads with a mains voltage of 230 Vac and power max 500 W.

Memorizes up to 30 transmitters.

Internal terminal board for connection.

Manages up to 2 timers for automatic switch off.

Maximum control versatility with 2 transmitter memorisation modes

Mode I: ON - OFF with separate buttons

Mode II: ON - OFF - MAN PRESENT - TIMER.

Timer can be programmed from a minimum of 0.5" to a maximum of approximately 9'.



CODE	DESCRIPTION	PC/PACK
TT1N	CONTROL UNIT FOR PASS THROUGH INSTALLATIONS FOR ONE 230 Vac MOTOR UP TO 500 W, WITH BUILT-IN RADIO-CONTROLLED RECEIVER. 2 PROGRAMMING MODES AND PROGRAMMABLE WORKING TIME	1
TT1L	CONTROL UNIT FOR PASS THROUGH INSTALLATIONS FOR LIGHTING/IRRIGATION SYSTEMS, 230 Vac MAX. 500 W, WITH BUILT-IN RADIO RECEIVER. 2 PROGRAMMING MODES AND 2 TIMERS FOR AUTOMATIC SWITCH OFF	1

### TECHNICAL SPECIFICATIONS

CODE	TT1N	TT1L
POWER SUPPLY (Vac/Hz)	230/50	
FREQUENCY (MHz)	433.92	
FOR TRANSMITTERS IN THE SERIES	ERA, NICEWAY, FLOR-S, FLO, VERYVE, VERYVR, SMILO	
MAXIMUM MOTOR POWER	500 W / 400 VA	
PROTECTION RATING (IP)	55	
MANOEUVRE DURATION (SEC)	PROG. 4-250	TIMER1 TIMER2 FROM 0.5" A 540"
WORKING TEMP. (°C MIN/MAX)	-20 ÷ +55	
DIMENSIONS (mm)	98x26x20	
WEIGHT (g)	45	



1	2	3	A
4	5	6	B
7	8	9	C
0	Nice		

# ACCESSORIES



SYSTEM OF PHOTOCELLS, KEY-OPERATED AND DIGITAL SELECTOR SWITCHES, TRANSPONDER READERS AND CONTROLLING ENTRIES	184	THE RANGE ERA GATE ACCESSORIES
	186	ERA PHOTOCELL S
	188	ERA PHOTOCELL M
	190	ERA PHOTOCELL L
	192	ERA KEYPAD
	193	ERA KEYPAD WIRELESS
	194	ERA KEY SWITCH
	195	ERA TRANSPONDER READER
	196	ERA POST

---

FLASHING LIGHTS	198	ERA LIGHT
	199	WALLYGHT

---

WIRELESS ACCESSORY SYSTEM	200	NICE SOLEMYO AIR NET SYSTEM
---------------------------	-----	-----------------------------

---

PHOTOCELLS AND SAFETY DEVICES	204	EVEN SAFER AUTOMATION
	206	FT210
	207	F210

---

KEY-OPERATED SELECTOR	208	KIO
	208	KIOMINI

# NICE ERA PHOTOCELLS, SELECTORS & PROXIMITY READER

The new Nice generation of optical devices  
for automation safety, available with Nice BlueBUS technology  
for a simplified installation.

Three different sizes of photocells  
synchronized to meet any need and complete  
the safety and comfort of every automation  
system, also in the tightest spaces, perfect  
for use with renovations to cover annoying  
existing set-ups.

## > SLIM

With only 30 mm width,  
also in burglar-proof version,  
ideal for tight spaces.



## > MEDIUM

In burglar-proof and positionable versions,  
ideal for the most popular systems.



## > LARGE

Positionable, also in versions for recessed  
mounting with 9 mm projection, ideal for concealed  
installations.





## > ERA KEYPAD

Extremely strong metal body, 27 millimetres depth and only 13 mm from the wall for the recessed mounting version.



### DIGITAL SELECTOR WIRELESS (EDSWG)

Digital selector in burglar-resistant version 13 keys.



### DIGITAL SELECTORS (EDS)

Digital selector in burglar-resistant version for outdoor and recessed installation.



### KEY SELECTORS WITH EUROPEAN CYLINDER (EKS)

Key selectors in version for outdoor or recessed mounting.



### KEY SELECTORS WITH STANDARD CYLINDER (EKS)

Key selectors in version for outdoor or recessed mounting.



### PROXIMITY READERS (ETP)

Proximity readers for card and badge reading.



### TRANSPONDER BADGE

Convenient transponder badge with a practical through hole to add the key chain on.

## > ERA KEY

Wafer thin, only 13 millimetres depth from the wall in the recessed versions.

## > ERA TRANSPONDER READER

Transponder proximity reader for cards and badges with customized programming.



# ERA PHOTOCELL S

NEW BLUEBUS

**Fixed, synchronized photocells Slim, also with Nice BlueBUS technology.**

**Safe:**

D type device according to specification EN12453 which allows to pick-up obstacles on the optical axis between transmitter (TX) and receiver (RX).

Using the fototest function it is possible to achieve class 2 safety fault according to specification EN 954-1.

**Cutting-edge technologies:**

antiglare circuit which eliminates possible sunlight interference.



EPS  
EPSB

EPSA  
EPSAB

**Practical:**

8° angle of reception.

**Resistant and vandal-proof:**

ABS body resistant to weather conditions, available also in burglar-resistant version with metal shell.

**Nice BlueBUS technology:**

available with the BlueBUS system, which allows an easy connection to the control unit of all devices with only two wires, by simply connecting them in parallel and selecting the jumpers for addressing according to the needed function.

The system acquires automatically the devices connected to the BlueBus network.

Automatic synchronization between multiple photocell pairs in order to avoid other possible interferences between the devices.

**IB interface:**

allows the connection of proximity readers with Nice BlueBUS technology to control units having terminals for traditional contacts.

**PHOTOCELLS**

CODE	DESCRIPTION	PCS./PACK.
EPS	PAIR OF OUTDOOR PHOTOCELLS SLIM	1
EPSA	PAIR OF OUTDOOR PHOTOCELLS SLIM, BURGLAR-RESISTANT METAL BODY	1

**PHOTOCELLS WITH NICE BLUEBUS TECHNOLOGY**

CODE	DESCRIPTION	PCS./PACK.
EPSB	PAIR OF OUTDOOR PHOTOCELLS SLIM, FOR CONNECTIONS VIA NICE BLUEBUS NETWORK	1
EPSAB	PAIR OF OUTDOOR PHOTOCELLS SLIM, FOR CONNECTIONS VIA NICE BLUEBUS NETWORK, BURGLAR-RESISTANT METAL BODY	1
IB	INTERFACE FOR PHOTOCELL BLUEBUS CONNECTION TO NON PREPARED STATIONS	1

**TECHNICAL SPECIFICATION**

	Estimated range (m)	Power supply	Absorption (mA)	Protection class (IP)	Operating temperature (°C Min/Max)	Relay range	Dimensions (mm)	Weight (g)
EPS	15	24 Vac/Vdc limits: 18-35 Vdc, 15-28 Vac	25 RX, 30 TX	44	-20 - +50	max 500 mA and 48 V	30x27x106 h	120
EPSA							31x28x108 h	440

**TECHNICAL SPECIFICATIONS WITH NICE BLUEBUS TECHNOLOGY**

	Estimated range (m)	Electric power supply output	Protection class (IP)	Operating temperature (°C Min/Max)	Dimensions (mm)	Weight (g)
EPSB	up to 15 for offset maximum TX-RX ± 5 (the device can signal an obstacle also in adverse weather conditions)	the devices can be connected only to "BlueBUS" networks from which it receives the power supply and transmits the output signals	44	-20 - +50	30x27x106 h	120
EPSAB					31x28x108 h	440

	Power supply	Absorption with power pack 24 Vdc	Absorption with power pack 24 Vac	Output BlueBUS	Protection class (IP)	Operating temperature (°C Min/Max)	Dimensions (mm)	Weight (g)
IB	16÷35 Vdc 18÷28 Vac	50 mA (add approx. 50 mA for each photocell pair)	44 mA (add approx. 40 mA for each photocell pair)	with a load of max 9 BlueBUS units	30	-20 - +50	86x58x22 h	72



IB

FOR SWING GATES

FOR SLIDING GATES

BARRIER GATE OPERATOR SYSTEMS

FOR GARAGE AND INDUSTRIAL DOORS

CONTROL SYSTEMS AND ACCESSORIES

COMPATIBILITY TABLE AND ALPHABETICAL INDEX



# ERA PHOTOCELL M

NEW BLUEBUS

**Synchronized photocells Medium, fixed or positionable, also with Nice BlueBUS technology.**

**Safe:**  
D type device according to specification EN12453 which allows to pick-up obstacles on the optical axis between transmitter (TX) and receiver (RX).

Using the fototest function it is possible to achieve class 2 safety fault according to specification EN 954-1.

**Cutting-edge technologies:**  
antiglare circuit which eliminates possible sunlight interference.

**Practical:**  
10° angle of reception. The positionable versions allow for the compensation of centering gaps up to 30°.  
The models EPM, EPMO, EPMA and EPMAO provide for 2 range levels.

**Resistant and vandal-proof:**  
ABS body resistant to weather conditions, available also in burglar-resistant version with metal shell.

**Nice BlueBUS technology:**  
all models are available with the BlueBUS system, which allows an easy connection to the control unit of all devices with only two wires, by simply connecting them in parallel and selecting the jumpers for addressing according to the needed function. The system acquires automatically the devices connected to the BlueBus network.

Automatic synchronization between multiple photocell pairs in order to avoid other possible interferences between the devices.

**IB interface:**  
allows the connection of photocells with Nice BlueBUS technology to control units having terminals for traditional contacts.



EPM  
EPMB

EPMO  
EPMOB

EPMA  
EPMAB

EPMAO  
EPMAOB

## PHOTOCELLS

CODE	DESCRIPTION	PCS./PACK.
<b>EPM</b>	PAIR OF OUTDOOR PHOTOCELLS	1
<b>EPMO</b>	PAIR OF OUTDOOR PHOTOCELLS, 30° POSITIONABLE	1

## PHOTOCELLS WITH NICE BLUEBUS TECHNOLOGY

CODE	DESCRIPTION	PCS./PACK.
<b>EPMB</b>	PAIR OF OUTDOOR PHOTOCELLS, FOR CONNECTIONS VIA NICE BLUEBUS NETWORK	1
<b>EPMOB</b>	PAIR OF OUTDOOR PHOTOCELLS, 30° POSITIONABLE, FOR CONNECTIONS VIA NICE BLUEBUS NETWORK	1

## PHOTOCELLS - BURGLAR-RESISTANT METAL BODY

CODE	DESCRIPTION	PCS./PACK.
<b>EPMA</b>	PAIR OF OUTDOOR PHOTOCELLS, BURGLAR-RESISTANT METAL BODY	1

## PHOTOCELLS - BURGLAR-RESISTANT METAL BODY WITH NICE BLUEBUS TECHNOLOGY

CODE	DESCRIPTION	PCS./PACK.
<b>EPMAB</b>	PAIR OF OUTDOOR PHOTOCELLS, FOR CONNECTIONS VIA NICE BLUEBUS NETWORK, BURGLAR-RESISTANT METAL BODY	1

## PHOTOCELLS - POSITIONABLE BURGLAR-RESISTANT METAL BODY

CODE	DESCRIPTION	PCS./PACK.
<b>EPMAO</b>	PAIR OF OUTDOOR PHOTOCELLS, 30° POSITIONABLE, BURGLAR-RESISTANT METAL BODY	1

## PHOTOCELLS - BURGLAR-RESISTANT POSITIONABLE METAL BODY WITH NICE BLUEBUS TECHNOLOGY

CODE	DESCRIPTION	PCS./PACK.
<b>EPMAOB</b>	PAIR OF OUTDOOR PHOTOCELLS, 30° POSITIONABLE, BURGLAR-RESISTANT METAL BODY, FOR CONNECTIONS VIA NICE BLUEBUS NETWORK	1

## ACCESSORIES

CODE	DESCRIPTION	PCS./PACK.
<b>IB</b>	INTERFACE FOR PHOTOCELL BLUEBUS CONNECTION TO NON PREPARED STATIONS	1

## TECHNICAL SPECIFICATION

	Estimated range (m)	Power supply	Absorption (mA)	Photocell adjustability	Protection class (IP)	Operating temperature (°C Min/Max)	Relay range	Dimensions (mm)	Weight (g)
<b>EPM</b>	15 (30 with jumper + "10" cut)	without jumper 24 Vac/Vdc limits: 18-35 Vdc, 15-28 Vac with 12 Vac/Vdc jumper limits: 10-18 Vdc, 9-15 Vac	25 RX, 30 TX	-	44	-20 - +50	max 500 mA and 48 V	50x29x80 h	140
<b>EPMO</b>				30° approx. on the all axes				50x38x80 h	160
<b>EPMA</b>				-				50x31x80 h	480
<b>EPMAO</b>				30° approx. on the all axes				50x38x80 h	530

## TECHNICAL SPECIFICATIONS WITH NICE BLUEBUS TECHNOLOGY

	Estimated range (m)	Electric power supply output	Photocell adjustability	Protection class (IP)	Operating temperature (°C Min/Max)	Dimensions (mm)	Weight (g)
<b>EPMB</b>	up to 15 for offset maximum TX-RX ± 5 (the device can signal an obstacle also in adverse weather conditions)	the device may be connected only to networks "BlueBUS" from which receives the electrical and transmits the signals output power supply	-	44	-20 - +50	50x29x80 h	140
<b>EPMOB</b>			30° approx. on the all axes			50x38x80 h	160
<b>EPMAB</b>			-			50x31x80 h	480
<b>EPMAOB</b>			30° approx. on the all axes			50x38x80 h	530

	Power supply	Absorption with power pack 24 Vdc	Absorption with power pack 24 Vac	Output BlueBUS	Protection class (IP)	Operating temperature (°C Min/Max)	Dimensions (mm)	Weight (g)
<b>IB</b>	16÷35 Vdc 18÷28 Vac	50 mA (add approx. 50 mA for each photocell pair)	44 mA (add approx. 40 mA for each photocell pair)	with a load of max 9 BlueBUS units	30	-20 - +50	86x58x22 h	72



IB

FOR SWING GATES

FOR SLIDING GATES

BARRIER GATE OPERATOR SYSTEMS

FOR GARAGE AND INDUSTRIAL DOORS

CONTROL SYSTEMS AND ACCESSORIES

COMPATIBILITY TABLE AND ALPHABETICAL INDEX

# ERA PHOTOCELL L

NEW BLUEBUS

**Synchronized photocells Large, fixed or positionable, also with Nice BlueBUS technology, both surface mounted and recessed.**

**Easy and versatile:**

recessed versions EPLIO compatible with the most popular standards on the market to replace the old photocells or cover annoying existing setups without the need of extra adaptors.

**Safe:**

D type device according to specification EN12453 which allows to pick-up obstacles on the optical axis between transmitter (TX) and receiver (RX).

Using the fototest function it is possible to achieve class 2 safety fault according to specification EN 954-1.

The models EPL, EPLO, EPLIO provide for 2 range levels.

**Cutting-edge technologies:**

antiglare circuit which eliminates possible sunlight interference.

The positionable versions allow for the compensation of centering gaps up to 30°.

**Discreet:**

polycarbonate body, extremely strong with minimal projection of 9 millimetres from the wall for the recessed mounting version.

**Practical:**

adapter bowl EKA03 to simplify useful preparations for recessed mounting.

**Nice BlueBUS technology:**

all versions with the BlueBUS system allow an easy connection to the control unit of all devices with only two wires, by simply connecting them in parallel and selecting the jumpers for addressing according to the needed function.

The system automatically acquires the devices connected to the BlueBus network and allows automatic synchronization with multiple photocells in order to avoid other possible interferences.

**IB interface:**

allows the connection of photocells with Nice BlueBUS technology to control units having terminals for traditional contacts.



EPL  
EPLB



EPLO  
EPL0B



EPLIO  
EPLIOB

## PHOTOCELLS

CODE	DESCRIPTION	PCS./PACK.
<b>EPL</b>	PAIR OF SURFACE-MOUNTED PHOTOCELLS LARGE	1

## PHOTOCELLS WITH NICE BLUEBUS TECHNOLOGY

CODE	DESCRIPTION	PCS./PACK.
<b>EPLB</b>	PAIR OF SURFACE-MOUNTED PHOTOCELLS LARGE, FOR CONNECTIONS VIA NICE BLUEBUS	1

## POSITIONABLE PHOTOCELLS

CODE	DESCRIPTION	PCS./PACK.
<b>EPL0</b>	PAIR OF SURFACE-MOUNTED PHOTOCELLS LARGE, 30° POSITIONABLE	1

## POSITIONABLE PHOTOCELLS, WITH NICE BLUEBUS TECHNOLOGY

CODE	DESCRIPTION	PCS./PACK.
<b>EPL0B</b>	PAIR OF SURFACE-MOUNTED PHOTOCELLS LARGE, 30° POSITIONABLE, FOR CONNECTIONS VIA NICE BLUEBUS	1

## POSITIONABLE PHOTOCELLS, FOR RECESSED MOUNTING

CODE	DESCRIPTION	PCS./PACK.
<b>EPLIO</b>	PAIR OF PHOTOCELLS LARGE FOR RECESSED MOUNTING, 30° POSITIONABLE	1

## SWIVEL PHOTOCELLS, FOR RECESSED MOUNTING WITH NICE BLUEBUS TECHNOLOGY

CODE	DESCRIPTION	PCS./PACK.
<b>EPLIOB</b>	PAIR OF PHOTOCELLS LARGE FOR RECESSED MOUNTING, 30° POSITIONABLE, FOR CONNECTION VIA NICE BLUEBUS	1

## ACCESSORIES

CODE	DESCRIPTION	PCS./PACK.
<b>IB</b>	INTERFACE FOR PHOTOCELL BLUEBUS CONNECTION TO NON PREPARED STATIONS	1
<b>EKA03</b>	BOWL FOR RECESSED MOUNTING (DEPTH 66 mm) FOR INSTALLATION OF EKSI, EKSIU. ALSO COMPATIBLE WITH EPLIO, EPLIOB, EDSI, EDSIB	50

## TECHNICAL SPECIFICATION

	Estimated range (m)	Power supply	Photocell adjustability	Absorption (mA)	Protection class (IP)	Operating temperature (°C Min/Max)	Relay range	Dimensions (mm)	Weight (g)
<b>EPL</b>	15 (30 with jumper + "10" cut)	without jumper 24 Vac/Vdc limits: 18-35 Vdc, 15-28 Vac with 12 Vac/Vdc jumper limits: 10-18 Vdc, 9-15 Vac	-	25 RX, 30 TX	44	-20 - +50	max 500 mA and 48 V	70x30x70 h	160
<b>EPL0</b>			30° approx. on the all axes					70x38x70 h	180
<b>EPLIO</b>								70x66+9x70 h	185

## TECHNICAL SPECIFICATIONS WITH NICE BLUEBUS TECHNOLOGY

	Estimated range (m)	Electric power supply output	Photocell adjustability	Protection class (IP)	Operating temperature (°C Min/Max)	Dimensions (mm)	Weight (g)
<b>EPLB</b>	up to 15 for offset maximum TX-RX ± 5 (the device can signal an obstacle also in adverse weather conditions)	the device may be connected only to "BlueBUS" networks from which it receives the electrical power and transmits the output signals	-	44	-20 - +50	70x30x70 h	140
<b>EPL0B</b>			30° approx. on the all axes			70x38x70 h	160
<b>EPLIOB</b>						70x66+9x70 h	185

	Power supply	Absorption with power pack 24 Vdc	Absorption with power pack 24 Vac	Output BlueBUS	Protection class (IP)	Operating temperature (°C Min/Max)	Dimensions (mm)	Weight (g)
<b>IB</b>	16÷35 Vdc 18÷28 Vac	50 mA (add approx. 50 mA for each photocell pair)	44 mA (add approx. 40 mA for each photocell pair)	with a load of max 9 BlueBUS units	30	-20 - +50	86x58x22 h	72



IB

FOR SWING GATES

FOR SLIDING GATES

BARRIER GATE OPERATOR SYSTEMS

FOR GARAGE AND INDUSTRIAL DOORS

CONTROL SYSTEMS AND ACCESSORIES

COMPATIBILITY TABLE AND ALPHABETICAL INDEX

# ERA KEYPAD

NEW

**12 key digital selector, also with Nice BlueBUS technology, available in the recessed mounting version.**

### Wafer-thin

extremely strong metal body, 27 millimetres depth and only 13 mm from the wall for the recessed mounting version.

### Safe:

the combination is a 1 to 9 digit number, this allows the generation of 999,999,999 possible combinations!

Backlit keypad.

### Easy programming:

- 2 programming modes: Easy or Professional;
- possibility to program the number of uses of a specific combination;
- 255 storable combinations expandable, on EDS and EDSI up to 510 combinations with a second additional memory BM1000.



EDS  
EDSB



EDSI  
EDSIB

With a 0-Box interface you can manage easily any kind of programming of the BM1000 memory, in proximity of the system or also at a distance, directly from the office of the installer.

0-Box is interfaced with the PC, thus allowing an orderly storing of all installations.

### Nice BlueBUS technology:

Available with BlueBus system which allows an easy connection to the control unit of all devices with only two wires, by simply connecting them in parallel and other exclusive functions:

- 2 keys for the activation of two different commands chosen among 6 available ones (for example, step operation, close, open), depending on the control unit to which they are connected to;
- up to 4 control devices EDSB/EDSIB and ETPB which can be connected also with a mixed configuration;
- possibility of insertion of a block/unblock function.

**Two different visual signalling** depending on the state of automation:

- red: when the automation is closed or is closing;
- green: during opening operation or in the case in which the "automation block" function is active.

### DIGITAL SELECTORS

CODE	DESCRIPTION	PCS./PACK.
<b>EDS</b>	DIGITAL SELECTOR, 12 KEYS, TO BE COMBINED WITH THE MORX DECODER	1
<b>EDSI</b>	DIGITAL SELECTOR, 12 KEYS, FOR RECESSED MOUNTING, TO BE COMBINED WITH THE MORX DECODER	1
<b>MORX</b>	DECODER FOR 1 ETP OR UP TO 4 EDS/EDSI CONNECTED IN PARALLEL, WITH 1 BM1000 MEMORY FOR 255 COMBINATIONS	1

### TECHNICAL SPECIFICATION

	Protection class (IP)	Dimensions (mm)	Weight (g)
<b>EDS</b>	44	70x27x70 h	200
<b>EDSI</b>	54	70x66+13x70 h	160

	Storage Capacity	Range relè	Power supply	Maximum absorption	Protection class (IP)	Operating temperature (°C Min/Max)	Dimensions (mm)	Weight (g)
<b>MORX</b>	2 BM1000 for max. 510 combinations or 510 MOCARD, MOCARDP and HSB1	max. 500 mA and 48 Vac/Vdc	10=35 Vdc, 12=28 Vac	24 Vdc=70 mA 24 Vac=200 mA 12 Vdc=150 mA 12 Vac=300 mA with 1 ETP or up to 4 EDS/EDSI	30	-20 - +70	98x42x25 h	65



MORX

### DIGITAL SELECTORS WITH NICE BLUEBUS TECHNOLOGY

CODE	DESCRIPTION	PCS./PACK.
<b>EDSB</b>	12 KEY DIGITAL SELECTORS WITH NICE BLUEBUS TECHNOLOGY BURGLAR-RESISTANT METAL BODY	1
<b>EDSIB</b>	12 KEY DIGITAL SELECTORS WITH NICE BLUEBUS TECHNOLOGY, FOR RECESSED MOUNTING BURGLAR-RESISTANT METAL BODY	1

### TECHNICAL SPECIFICATIONS WITH NICE BLUEBUS TECHNOLOGY

	Power supply	Absorption	Protection class (IP)	Dimensions (mm)	Weight (g)
<b>EDSB</b>	via BlueBUS	1.5 BlueBUS units	44	70x27x70 h	200
<b>EDSIB</b>			54	70x66+13x70 h	160

### AUXILIARY EQUIPMENT FOR RECESSED MOUNTING VERSIONS

CODE	DESCRIPTION	PCS./PACK.
<b>EKA03</b>	BOWL FOR RECESSED MOUNTING (DEPTH 66 mm) FOR INSTALLATION OF EKSI, EKSIÊU. ALSO COMPATIBLE WITH EPLIO, EPLIOB, EDSI, EDSIB	50
<b>EKA02</b>	FINISHING KIT FOR EDSI, EDSIB, EKSI, EKSIÊU INSTALLATION	10



# ERA KEYPAD WIRELESS

NEW

**12 key digital selectors, with radio connection, 100% wireless.**

**Digital radio selector with FloR 52 bit coding ;** is compatible with FloR with rolling code and generates 4.5 trillions of combinations, self-learning.

**Complete:**  
3 transmission channels to control 3 automated systems or 3 different customized commands for the single automated system.

**Comfortable:**  
no cabling needed and an estimated range of 25 m in free space and 15 m inside buildings.  
Backlit keypad.



**Safe:**  
the combination is a 0 to 8 digit number, this allows the generation of 99,999,999 possible combinations!

**Economic:**  
extremely reduced consumption, transmission is activated at the pressure of a key and turns off automatically. The ambient light sensor activates lighting of the keyboard only when this is necessary.

**Strong:**  
vandal-proof container in metal casting, IP54.

**Thin:**  
extremely strong metal body, only 27 millimetre depth.

## DIGITAL WIRELESS SELECTOR

CODE	DESCRIPTION	PCS./PACK.
EDSWG	RADIO DIGITAL SELECTOR COMPATIBLE WITH THE RECEIVERS OF THE FLOR SERIES	1

## TECHNICAL SPECIFICATION

	Power supply	Battery lifetime	Frequency	Radiated power	Radio coding	Operating temperature (°C Min/Max)	No. of digits combination	Estimated range (m)	Degree of safety (IP)	Dimensions (mm)	Weight (g)
EDSWG	6 Vdc with 2 lithium batteries type CR2430	estimated 2 years with 10 transmissions per day	433.92 MHz ± 100 KH	estimated about 3 mW e.r.p.	rolling code 52 bit FloR	-20° - +55°	from 0 to 8	25 in open space, 15 indoors	54	70x27x70 h	215

FOR SWING GATES

FOR SLIDING GATES

BARRIER GATE OPERATOR SYSTEMS

FOR GARAGE AND INDUSTRIAL DOORS

CONTROL SYSTEMS AND ACCESSORIES

COMPATIBILITY TABLE AND ALPHABETICAL INDEX

# ERA KEY SWITCH

NEW

**Key selectors for outdoor and recessed installation with automatic return lock, European or standard cylinder.**

**Selectors in burglar-resistant version with metal shell.**

**Wafer thin:**

only 13 millimetres depth from the wall in the recessed versions (32 and 45 millimetres in the outdoor versions).

Electrical contacts and levers protected by plastic container.

Employable as direct motor command in applications with mains power source (230 Vac).

**Flexible solution:**

recessed versions with bowl supplied, for new installations or existing setups with adaptor EKA02.



EKSEU



EKSIEU



EKS



EKSI

## KEY SELECTORS

CODE	DESCRIPTION	PCS./PACK.
<b>EKSEU</b>	KEY SELECTOR ERA SERIES, EUROPEAN CYLINDER, FOR OUTDOOR INSTALLATION	1
<b>EKSIEU</b>	KEY SELECTOR ERA SERIES, EUROPEAN CYLINDER, FOR RECESSED MOUNTING	1
<b>EKS</b>	KEY SELECTOR ERA SERIES, FOR OUTDOOR INSTALLATION	1
<b>EKSI</b>	KEY SELECTOR ERA SERIES, FOR RECESSED MOUNTING	1

## ACCESSORIES

CODE	DESCRIPTION	PCS./PACK.
<b>CHS</b>	NEUTRAL KEY FOR EKS, EKSI	1
<b>CHEU</b>	NEUTRAL KEY FOR EKSEU, EKSIEU	1
<b>EKA03</b>	BOWL FOR RECESSED MOUNTING (DEPTH 66 mm) FOR INSTALLATION OF EKSI, EKSIEU. ALSO COMPATIBLE WITH EPLIO, EPLIOB, EDSI, EDSIB	50
<b>EKA02</b>	FINISHING KIT FOR EDSI, EDSIB, EKSI, EKSIEU INSTALLATION	10

## TECHNICAL SPECIFICATION

	Contact range	Protection class (IP)	Dimensions (mm)	Weight (g)
<b>EKSEU</b>	10 (2) A - 250 Vac	44	70x43x70 h	490
<b>EKSIEU</b>			70x66+13x70 h	530
<b>EKS</b>			70x32x70 h	360
<b>EKSI</b>			70x66+13x70 h	450

# ERA TRANSPONDER READER

NEW

**Transponder proximity reader for cards and badges, bimodal transmitters Flor-m, also with Nice BlueBUS technology.**

### Easy programming:

- 2 programming modes: Easy or Professional;
- allows you to determine which cards/badges are enabled on the system;
- possibility of programming the number of uses available to a specific card or badge;
- 255 storable cards/badges expandable, on ETP, up to 510 cards/badges with a second additional memory BM1000.
- 2 modes (static and dynamic) to activate two different commands (ETP version).



With a 0-Box interface you can manage easily any kind of programming of the BM1000 memory, in proximity of the system or also at a distance, directly from the office of the installer. 0-Box is interfaced with the PC, thus allowing an orderly storing of all installations.

### Nice BlueBUS technology:

available with BlueBUS system which allows an easy connection to the control unit of all devices with only two wires, by simply connecting them in parallel and other exclusive functions:

- 2 modes (static and dynamic) for the activation of two different commands chosen among 6 available ones (for example, step operation, close, open), depending on the control unit to which they are connected to;
- possibility of inserting an automation block/unblock function;
- up to 4 control devices EDSB/EDSIB and ETPB which can be connected via BlueBUS, also with a mixed configuration;

### Transponder badge HSB1

Practical in use, can be added to the key chain so as to be always available.

### PROXIMITY READER

CODE	DESCRIPTION	PCS./PACK.
ETP	PROXIMITY READER FOR TRANSPONDER CARDS MOCARD AND MOCARDP TO BE COMBINED WITH THE MORX DECODER	1
MORX	DECODER FOR 1 ETP OR UP TO 4 EDS/EDSI CONNECTED IN PARALLEL, WITH 1 BM1000 MEMORY FOR 255 COMBINATIONS	1
BM1000	ADDITIONAL MEMORY FOR ADDITIONAL 255 COMBINATIONS	5

### PROXIMITY READER WITH NICE BLUEBUS TECHNOLOGY

CODE	DESCRIPTION	PCS./PACK.
ETPB	PROXIMITY READER FOR TRANSPONDER CARDS WITH NICE BLUEBUS TECHNOLOGY	1

### ACCESSORIES

CODE	DESCRIPTION	PCS./PACK.
MOCARD	TRANSPONDER CARD PROGRAMMABLE VIA OBOX	10
MOCARDP	TRANSPONDER CARD PROGRAMMABLE VIA OBOX, WITH SEQUENTIAL CODING FOR MULTIPLE ENTRY	10
HSB1	TRANSPONDER BADGE NEWLY PROGRAMMABLE VIA OBOX, WITH SEQUENTIAL CODING FOR MULTIPLE ENTRY	10

### TECHNICAL SPECIFICATION

	Description	Acquisition distance (cm)	Protection class (IP)	Dimensions (mm)	Weight (g)
ETP	MOCARD, MOCARDP and HSB1 reader	3 - 6	54	70x26x70 h	265

	Storage capacity	Range relè	Power supply	Maximum absorption	Protection class (IP)	Operating temperature (°C Min/Max)	Dimensions (mm)	Weight (g)
MORX	2 BM1000 for max. 510 MOCARD and MOCARDP or combination	max. 500 mA and 48 Vac/Vdc	10÷35 Vdc 12÷28 Vac	24 Vdc=70 mA 24 Vac=200 mA 12 Vdc=150 mA 12 Vac=300 mA (with 1 MOM or 4 MOT)	30	-20 - +55	98x42x25 h	65



MORX

### TECHNICAL SPECIFICATIONS WITH NICE BLUEBUS TECHNOLOGY

	Power supply	Absorption	Acquisition distance (cm)	Protection class (IP)	Dimensions (mm)	Weight (g)
ETPB	via BlueBUS	2 BlueBUS units	up to 4	54	70x26x70 h	270

# ERA POST

NEW

**Outdoor aluminium posts for photocells, selectors and proximity readers, with height 500 mm and 1000 mm.**

## Modern design

New post line for the installation of medium and large sized photocells.

## Easy installation

Simplified installation for the setting in absolute freedom of one's own safety area .

CODE	DESCRIPTION	PCS./PACK.
PPH1	ALUMINIUM POST WITH PROTECTED HOUSING FOR 1 PHOTOCCELL MEDIUM AND LARGE, 500 mm h	2
PPH2	ALUMINIUM POST WITH PROTECTED HOUSING FOR 2 PHOTOCCELLS MEDIUM AND LARGE, 1000 mm h	2
PPH3	ALUMINIUM POST WITH PROTECTED HOUSING FOR 1 PHOTOCCELL MEDIUM SIZE, 500 mm h	2
PPH4	ALUMINIUM POST WITH PROTECTED HOUSING FOR 2 PHOTOCCELLS MEDIUM SIZE, 1000 mm h	2
PPK	ALUMINIUM POST WITH HOUSING FOR 1 SELECTOR 1100 mm h	2
EKA01	PLUG FOR MOUNTING OF EKS, EKSEU, EDS, EDSB, EDSWG, ETP, ETPB, ON PPH2 POST	1



	EPM/EPMB	EPMD/EPMD8	EPL/EPLB	EPLD/EPLDB	PHW**	EDS/EDSB	EDW	ETP/ETPB	EKS	EKSEU
PPH1	●	●	●	●	●					
PPH2	●	●	●	●		●*	●*	●*	●*	●*
PPH3	●	●								
PPH4	●	●								
PPK						●	●	●	●	●

\*The installation requires the EKA01 plug adaptor.

\*\*The installation of the solar photocell requires the PHWA1 plug adaptor.



PPH3



PPH1



PPH4



PPH2



PPK

# ERA LIGHT

NEW

## Flashing signalling light.

**Available with different power supplies:**  
230 Vac, 24 Vdc and 12 Vdc.

**Practical:** body extremely resistant to shocks, suitable for fixing in any position.

**433.92 MHz antenna integrated in all versions.**

Protection class IP44.



CODE	DESCRIPTION	PCS./PACK.
EL	NEUTRAL, 230 Vac, FOR PRESET CONTROL UNITS	1
EL24	NEUTRAL, 24 Vac/Vdc, FOR PRESET CONTROL UNITS	1
ELB	NEUTRAL, 12 Vac/Vdc, FOR PRESET CONTROL UNITS	1

## VERSATILE, SUITABLE FOR ANY ARCHITECTURAL CONTEXT



## RECOMMENDED INSTALLATION MODE



## COMPATIBILITY TABLE CONTROL UNIT / LIGHTS

	A02	A500	A60	A700F	A924	MC824H	MC424L	WALKY	HYKE	ROAD	ROBUS	RUN	NAKED SLIDING 400	TUB	SPIN / SPINBUS	TEN	SOON	S/M/L BAR	WIDE
EL	●	●	●	●										●					
EL24					●		●												●
ELB						●		●	●	●	●	●	●		●	●	●	●	

# WALLYGHT

**Optimal efficiency, extra long life:**  
the two 1 W-Leds guarantee a lifetime of 70.000 hours (continuous use).

**Horizontal, wall or ceiling mounting:** combined with the possibility of orienting the light beam and compact dimensions of the IP44 box, use of Wallyght is even more flexible.

## Multi-function LED indicator.

**The only version with 12/24 Vac/Vdc** power supply and flashing light function, courtesy light function or dusk sensor function.

**A new idea for improved safety:**  
when connected to compatible control units, Wallyght can act as a normal flashing light, or provide ambient lighting like a fixed courtesy light. When connected to a 12/24 Vac/Vdc output, Wallyght can remain permanently lit, and also be activated at dusk to then turn off at dawn thanks to the integrated dusk sensor.



CODE	DESCRIPTION	PC/PACK
WLT	MULTI-FUNCTION LED INDICATOR	1

## PATH INDICATORS ON ENTRANCE PATHWAYS



## COURTESY LIGHT

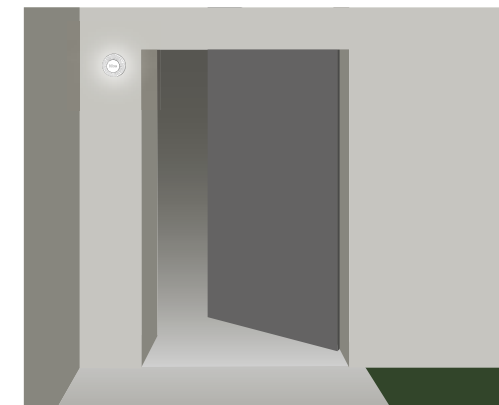

## RECOMMENDED INSTALLATION MODE

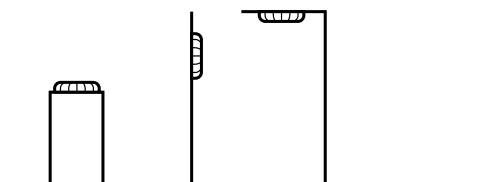

## COMPATIBILITY TABLE CONTROL UNIT / LIGHTS

	A924	MC824H	MC424L	WALKY	POP	HYKE	ROAD	ROBUS	RUN	NAKED SLIDING 400	SPIN / SPINBUS	SPIDER / SPIDO	TEN	SOON	WIDE
WLT	●	●	●	●	●	●	●	●	●	●	●	●	●	●	●

# NICE SOLEMYO AIR NET SYSTEM

**Automation safety devices becomes  
wireless control systems!**

Photocells, sensitive edge and flashing lightings all acquire a new function: power is supplied by means of an integral miniature solar panel. The solar panel powers rechargeable batteries to ensure independent operation of the automation system in any conditions.



**Era Light Solemyo**  
Flashing light



**Kit Solemyo**  
Solar power kit



**Era TCW Solemyo**  
Sensitive edge transmitter



**Era Photocell Solemyo**  
Photocell



**Era Post Solemyo**  
Solemyo  
Era Photocell Post





# SOLEMYO

SOLEMYO 24V

**Solemyo is the solar power system to automate gates, garage doors and road barriers, even those located far from the electrical mains.**

Solemyo is available both in kit version and single products.

**Installable anywhere** without the need for connections or excavations, even in the most remote locations or those difficult to access with the power mains.

**Increased savings and respect for the environment** thanks to solar energy, free and clean: an ecological and intelligent choice with short term benefits.

**Low consumption with no risk of blackouts:** the extended duration of the energy reserve, combined with the low consumption of the automations, guarantee operation also in prolonged overcast conditions.

## THE KIT CONTAINS:

**SYP:** PHOTOVOLTAIC PANEL FOR 24 V SUPPLY.  
**PSY24:** 24 V BATTERY BOX WITH CONTROL CIRCUIT AND CARRY HANDLES. IT STORES THE ELECTRICAL ENERGY PRODUCED BY THE SYP PANEL, WITH CONTINUOUS AND PERMANENT SUPPLY THROUGHOUT THE DAY.  
**CABLES AND CONNECTORS NECESSARY FOR THE CONNECTION.**



SYKCE

PSY24

SYP

**Less consumption, more autonomous operation!**  
 Perfect operation ensured even at night time or in prolonged overcast conditions, guaranteeing comfort and safety.

**Ease of use**  
 The SYA1 auxiliary power supply unit enables rapid battery charging via a 230 Vac power mains, as an alternative to the photovoltaic module. Battery charge status LED indicators.

**Installation advice**  
 If two or more parallel-connected solar panels have to be installed, purchase individually the items that make up the Solemyo system to increase the system's charging capacity or use just one SYA1 transformer to charge several PSY24 battery boxes.

CODE	DESCRIPTION	PACK/PALLET
<b>SYKCE</b>	SOLAR POWER KIT COMPRISING SYP PHOTOVOLTAIC PANEL AND PSY24 BATTERY BOX WITH CHARGING CONTROL CIRCUIT	21
<b>SYP</b>	PHOTOVOLTAIC PANEL FOR 24 V SUPPLY WITH MAXIMUM POWER 15 W	
<b>SYP30</b>	PHOTOVOLTAIC PANEL FOR 24 V SUPPLY WITH MAXIMUM POWER 30 W	
<b>PSY24</b>	24 V BATTERY BOX WITH CONTROL CIRCUIT AND CARRY HANDLES	

**N.B.** The content of the package may vary: consult the retailer.

## TECHNICAL SPECIFICATIONS

CODE	PSY24	SYP30	SYP	SYA1
POWER SUPPLY (Vac 50/60 Hz)		-		110 ÷ 240
RATED VOLTAGE (V)		24		-
MAXIMUM CURRENT (A)	10		-	
PEAK POWER (Wp)	-	30	15	-
MAXIMUM POWER (W)		-		60
RATED BATTERY CAPACITY (Ah)	20		-	
PROTECTION LEVEL (IP)	44		-	
WORKING TEMP. (°C MIN/MAX)	-20 ÷ +50*		-40 ÷ +85	0 ÷ +40
COMPLETE RECHARGING TIME (HOURS)	~ 15**		-	
DIMENSIONS (mm)	235x170x258 h	450x25x550 h	390x28x415 h	132x58x30 h
WEIGHT (kg)	14	3.5	1.9	0.345

\* 0 ÷ 40 if recharged from the power mains with SYA1 power supply unit.  
 \*\* Using the power supply unit via the mains.

## ACCESSORIES



**SYA1**  
 POWER SUPPLY UNIT FOR CHARGING THE BATTERY PSY24 FROM THE SUPPLY MAINS.

PC/PACK 1

## INSTALLATION DIAGRAM



FLEXIBLE: SOLEMYO ADAPTS PERFECTLY TO ALL TYPES OF INSTALLATION.



**The SYP30 photovoltaic panel,** sold individually, is ideal in all the situations with low exposure to the sun or automations with high intensity of use.

# NICE SOLEMYO AIR NET SYSTEM

## So many benefits!

**Quick installation:** no need to lay wiring to connect the accessories to the control unit, drilling holes or laying raceways: just position them as appropriate and let the control unit identify them.

Devices interface with the control unit by means of a special, very compact interface module that can be fitted directly inside the motor, or the control unit, if separate.

## Better appearance, flexible positioning of devices over time:

it is very easy to add (or remove) devices, with no need to search for a mains connection point or a contact for series connection.

## Extremely reliable transmission:

### the radio system allows two-way communication -

each device does not just respond to the control unit's instructions but sends a feedback signal, confirming that it is present and operational, and it also signals the occurrence of events such as the passage of an object between the two photocells.

## Operating Frequency: 868 MHz, less liable to interference.

Two separate channels are used, for a 100% guarantee of the system's operation and safety even in case of sudden interference.

**Intelligent system:** it detects whether any interference is from another Nice wireless automation unit.

In this case, the "new" automation system just installed selects two communication channels different from those used by the existing system, keeping the two systems' channels separate.

Each device has LEDs in the bottom indicating the signal quality and troublefree operation of the system, which can be checked immediately in the event of malfunction or at first start-up.

A LED flashes when the device is receiving enough solar power to allow recharging.

## Solemyo Era Photocell

**Pair of PHW two-way wireless photocells,** with photovoltaic cell power supply.

**Easy installation:** the receiver photocell has a special LED that indicates the degree of alignment with the transmitter photocell, very useful during initial installation.

## Solemyo Era Light

**Wireless LLW flashing light,** with extremely high-efficiency LEDs lower consumption and virtually unlimited lifetime (no more blown lamps needing frequent changing).

Light output adapts to ambient conditions to ensure good visibility even in direct sunlight and to save energy during the hours of darkness.

Can be used as flashing signal or courtesy light.

## COMPATIBILITY/INTERFACE TABLE

	PHW	LLW	TCW1	TCW2
<b>Control units with BLUEBUS system (*)</b>	With IBW	With IBW	With IBW (**)	With IBW (**)
<b>Control units without BLUEBUS system</b>	Not possible	Not possible	With IRW	With IRW

(\*) There may be any limitations on the number of devices managed.

(\*\*) Not managed in automation for swing gates (MC824H; Walky; Hopp; Hyke) and in some automations for garage doors ( SN6020\*; SN6021\*; SPIN2\*; SPIN20\*; SPIN21\*; SPOK).

CODE	DESCRIPTION	PC/PACK
<b>PHW</b>	PAIR OF WIRELESS PHOTOCELLS WITH BUILT-IN PHOTOVOLTAIC PANEL	1
<b>PPH1</b>	PHW PHOTOCELL POST, h. 50 cm	2
<b>PHWA1</b>	PAIR OF ADAPTERS FOR PHW ON PPH1 POSTS	1
<b>LLW</b>	WIRELESS FLASHING LIGHT WITH BUILT-IN PHOTOVOLTAIC PANEL	1
<b>IBW</b>	INTERFACE BETWEEN PHW/LLW AND CONTROL UNITS WITH BLUEBUS SYSTEM	1



# ERA TCW

NICE&SAFE

**Even safer automation thanks to the Nice Solemyo Air Net System's new sensitive edge sensors.**

**No connection, totally wireless, powered by the sun.**

### Energy saving

thanks to the solar power cell built into the TCW2, with rechargeable batteries.

Version with battery-only operation is also available in case of installations with low exposure to sunlight.

**Unbeatable safety** thanks to the "wireless" system for detection and communication between sensitive edge, interface and control unit, allowing swift action when an obstacle is detected.

### Quick and easy to install:

maximum flexibility in installing the devices.  
Possibility of connection to 8.2 KOhm resistive sensitive edges.

**State-of-the-art technology: IBW interfaces,** for Nice BlueBus-compatible control units, and **IRW**, interfaces, for control units without BlueBus connection, allow radio communication with **TCW** sensors.

### Suitable for any architectural context

Compact size: 99x49x33.



TCW2

TCW1

CODE	DESCRIPTION	PC/PACK
<b>TCW1</b>	BATTERY -POWERED WIRELESS TRANSMITTER FOR SENSITIVE EDGES. SUITABLE FOR INTERNAL USE OR SPARSELY SUNNY AREAS	1
<b>TCW2</b>	PHOTOVOLTAIC PANEL AND RECHARGEABLE BATTERY-POWERED WIRELESS TRANSMITTER FOR SENSITIVE EDGES. SUITABLE FOR EXTERNAL USE OR SUNNY AREAS	1
<b>IBW</b>	BLUEBUS WIRELESS INTERFACE FOR SENSITIVE EDGES WITH WIRELESS TRANSMITTER FOR BLUEBUS SYSTEM CONTROL UNITS	1
<b>IRW</b>	RELAY WIRELESS INTERFACE FOR SENSITIVE EDGES WITH WIRELESS TRANSMITTER FOR CONTROL UNITS WITH CLASSICAL CONNECTIONS (STOP AND PHOTO)	1

### TECHNICAL SPECIFICATIONS

CODE	TCW2	TCW1
TECHNOLOGY USED	RADIO DATA RECEPTION AND TRANSMISSION, WITH CHOICE OF 2 FREQUENCIES IN THE 868 MHz BAND	
POWER SUPPLY	PHOTOVOLTAIC CELL WITH ELECTRICITY STORED IN A RECHARGEABLE AAA NIMH BATTERY	2 ALKALINE BATTERIES
BATTERY LIFE	ESTIMATED 4-5 YEARS *	ESTIMATED 2-3 YEARS, WITH 1200 MAH ALKALINE BATTERIES
MAXIMUM NUMBER OF OPERATIONS PER DAY	15 OPERATIONS LASTING NO MORE THAN 1 MINUTE (1 CYCLE = OPENING + CLOSING)	
SENSITIVE EDGE (RS) INPUT RANGE	TYPICALLY 8,2 KOhm	
RADIO OPERATING RANGE (MAX)	20M (40M)	
FAILSAFE CATEGORY	2 (UNDER EN 945-1 STANDARD) DEPENDING ON "FOTOTEST" INPUT AND OUTPUT CONNECTION TYPE	
HOUSING PROTECTION RATING	IP44	
OPERATING TEMPERATURE	-20 ÷ +55°C	
DIMENSIONS (mm)	99x49x33	
WEIGHT (g)	130	145

\* The stated estimates refer to edges functioning for about 15 operations per day, with complete cycle time of 60 seconds (900 seconds per day).

### INSTALLATION DIAGRAM

\*IBW or IRW depending on the motor (only IBW accepts also PHW and LLW)

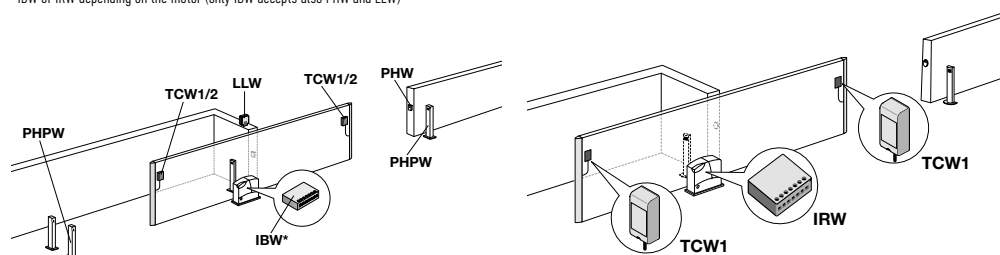

#### TCW + IBW

The IBW is connected to the control unit's BlueBUS terminal and communicates with the TCW by radio. Compatible also with PHW wireless photocell and LLW wireless flashing light.

#### TCW + IRW

IRW is connected to safety input (Stop and Photo) of control unit and communicates via radio with TCW.

FOR SWING GATES  
FOR SLIDING GATES  
BARRIER GATE OPERATOR SYSTEMS  
FOR GARAGE AND INDUSTRIAL DOORS  
CONTROL SYSTEMS AND ACCESSORIES  
COMPATIBILITY TABLE AND ALPHABETICAL INDEX

## 8.2 KOhm resistive sensitive edges, maximum safety and control of the automation.

**Safer:** if there are any faults in the system like, for example, the product itself has broken down, the edges will communicate this to the control unit. The TCE interface board enables users to connect sensitive edges (with 8.2 KOhm resistance) to those control units which are not equipped with a special input.

### The length can be personalised:

the components supplied in the kits enable installers to build sensitive edges of the correct dimension.

**Practical:** they adapt to any kind of situation and can be installed quickly.

**Reliable:** the new Class3 technology means that the control unit, the sensitive edges are connected to, can understand if the device is functioning correctly, or if it is out of use.

### 8.2 KOhm analogical-type input.



TCB65



TCK



TCF



TCA65

### Resistive sensitive edges and accessories

CODE	DESCRIPTION	PACK
TCB65	SENSITIVE EDGE IN 10 m ROLLS	1
TCK	KIT PUTTING TOGETHER 8 SENSITIVE EDGES COMPLETE WITH: - TERMINAL CAPS (TCT65) - CONNECTORS, COMPLETE WITH CABLE L=250 CM (TCS250) - CONNECTORS 8.2 KOHM (TCER) - TIN OF GLUE (TCC) - TIN OF PRIMER (TCP)	16 8 8 1 1
TCF	SCISSORS FOR CUTTING SAFETY SENSITIVE EDGES	1
TCA65	ALUMINIUM PROFILE L=200 CM	5
TCE	CONTROL INTERFACE FOR SENSITIVE EDGE	1

### Electrical connection devices for safety sensitive edges on moveable leafs

CODE	DESCRIPTION	PACK
DBM5	COMPLETE KIT FOR GATES UP TO 5 m	1
DBM7,5	COMPLETE KIT FOR GATES UP TO 7.5 m	1
DBM10	COMPLETE KIT FOR GATES UP TO 10 m	1

### Instruments and software for force impact measurement

CODE	DESCRIPTION
NSFB	BLUEFORCE SMART INSTRUMENT FOR MEASURING THE IMPACT FORCE COMPLIANT WITH EN12445, WITH BLUETOOTH/USB INTERFACE AND SOFTWARE INCLUDED, COMPLETE WITH CARRY CASE
NSFS	BLUEFORCE SMART INSTRUMENT FOR MEASURING THE IMPACT FORCE COMPLIANT WITH EN12445, WITH USB INTERFACE AND SOFTWARE INCLUDED COMPLETE WITH CARRY CASE
NSEL	STRAIGHT EXTENSION FOR MEASUREMENTS FROM 30 TO 50 CM, APPLICABLE ON NSFB AND NSFS
NSEA	ANGULAR EXTENSION FOR MEASUREMENTS FROM 1.25 TO 2.50 m, APPLICABLE ON NSEL



TCE



DBM5, DBM7,5, DBM10



NSFB, NSFS

## Mechanical sensitive edges, more safety and easy installation.

**CMA** is the pre-assembled, high mechanical edge consisting in aluminium profiles of 1.5 - 1.7 - 2 - 2.5 m in length; ideal for assembly on sliding or swing gates.

**CMBK** is the kit for installing a low mechanical edge: for edges max. 4 m (CMBK4) and for edges max. 6 m (CMBK6), ideal for garage doors in general, up-and-over and sectional doors.

**CB** is a protective rubber pad. Fitted to the CMBK4/CMBK6 kit, it forms the low mechanical edge.

### Mechanical sensitive edges

CODE	DESCRIPTION	PACK
	HIGH MECHANICAL EDGE WITH ALUMINIUM PROFILES IN SECTIONS MEASURING 1.5 - 1.7 - 2 - 2.5 m IN mm 36x75 h:	
<b>CMA 1,5MT</b>	LENGTH 1.5 m	1
<b>CMA 1,7MT</b>	LENGTH 1.7 m	1
<b>CMA 2MT</b>	LENGTH 2 m	1
<b>CMA 2,5MT</b>	LENGTH 2.5 m	1
<b>CB</b>	PROTECTIVE RUBBER PAD FOR LOW ROLLED MECHANICAL EDGE AND ALUMINIUM PROFILES IN SECTIONS MEASURING 2 m; DIMENSIONS IN mm 23x44 h	40
<b>CMBK4</b>	KIT FOR INSTALLING A LOW MECHANICAL EDGE, WITH ALUMINIUM PROFILES MEASURING 4 m (TO USE TOGETHER WITH CB)	1
<b>CMBK6</b>	KIT FOR INSTALLING A LOW MECHANICAL EDGE, WITH ALUMINIUM PROFILES MEASURING 6 m (TO USE TOGETHER WITH CB)	1

### Passive sensitive edges

CODE	DESCRIPTION	PACK
<b>TCBS60</b>	PASSIVE SENSITIVE EDGE IN 10 m ROLLS	1



CMA



CB



TCBS60

## Inductive magnetic detector loop.

Magnetic sensor for the detection of metal objects.

**Simple and safe:** operation and parameters are easily controlled, checked and programmable via the LCD display.

**Quick and versatile:** unlimited functions and simple, intuitive programming.

### Integrated measurement system

Automatic indication of loop inductance.

CODE	DESCRIPTION	PACK
<b>LP1</b>	SINGLE-CHANNEL METAL MASS DETECTOR 24 V POWER SUPPLY	1
<b>LP2</b>	TWO-CHANNEL METAL MASS DETECTOR 24 V POWER SUPPLY	1



LP1, LP2

# FT210

NICE&SAFE

BLUEBUS

**Optical device, with wireless transmitter to secure on moveable leaf, horizontally adjustable through 210° and 30° vertically, for an automation according to Standards.**

### Consideration towards personal safety and product quality.

The safety level of the main edge, required by the EN12453 standard, can be achieved for any "type of use" and any "type of activation" by integrating a FT210/FT210B device to an 8.2 KOhm TCB65 type resistive sensitive edge.

The FT210/FT210B device, integrated with a "resistive" sensitive edge (8.2 KOhm), is safe against individual faults (category 3 according to the EN 954-1 standard) or can be used with automated systems with self-diagnosis at the start of every manoeuvre (category 2 according to the EN 954-1 standard).

### Additional models

Versions with relay output (FT210), with Nice BlueBUS technology (FT210B), available with 2 Ah (FTA2) and 7Ah (FTA1) battery Kit, for intensive use.

### Cutting-edge technology

The anti-collision circuit avoids interference with other out-of-sink receivers.

The FT210/FT210B optical devices are equipped with a special sensor capable of recognizing when the gate is motionless, which remains in a low consumption mode and activates only when the gate is in motion. Range adjustable on 2 levels; alignment with proportional LED for easy and safe installation.

### Suitable for any architectural environment and easy to install

Reduced dimensions: 46x128x45; electrical connections can also be made from the lower section of the box.

### Resilient and safe

Polycarbonate casing; FA1 vandal-proof metal shell (optional); low transmitter battery indicator.



PPH2



PPH1



FA1, FA2

CODE	DESCRIPTION	PC/PACK
FT210	PAIR OF OPTICAL DEVICES FOR SENSITIVE EDGES FASTENED ON MOVING DOOR, CAN BE SWIVELLED THROUGH 210° WITH RELAY OUTPUT. BATTERY KIT (FTA1/FTA2) COMPULSORY	1
FT210B	PAIR OF OPTICAL DEVICES FOR SENSITIVE EDGES FASTENED ON MOVING DOOR, CAN BE SWIVELLED THROUGH 210° WITH BLUEBUS TECHNOLOGY. BATTERY KIT (FTA1/FTA2) COMPULSORY	1

### TECHNICAL SPECIFICATIONS

	Estimated range (m)	Power supply	Absorption	Protection rating (IP)	Working temp. (°C Min/Max)	Range relè	Dimensions (mm)	Weight (g)
FT210	10 (residential), 15 (industrial)	RX: 12-24 Vac/Vdc limits: 18-35 Vdc, 10-28 Vac TX: 3.6 V lithium battery	RX: 120 mA - 12 V, 70 mA - 24 V TX : 20 uA gate not moving, 450 uA gate operating	44	-20 ÷ +55	max 500 mA and 48 V	46x45x128 h	300
FT210B		RX: the device can only be connected to "BlueBUS" networks	1 BlueBUS unit TX : 20 uA gate not moving, 450 uA gate operating					280

### ACCESSORIES

CODE	DESCRIPTION	PC/PACK
FA1	VANDAL-PROOF METAL SHELL	2
FA2	BRACKET FOR FIXING TO PPH2 AND PPH1 COLUMNS	5
FTA1	7 Ah BATTERY KIT FOR FT210/FT210B TRANSMITTERS, FOR INTENSIVE USE	1
FTA2	2 Ah BATTERY KIT FOR FT210/FT210B TRANSMITTERS	1
PPH2	ALUMINIUM POST FOR 2 PHOTOCELLS, 1000 mm HIGH	2
PPH1	ALUMINIUM POST FOR 1 PHOTOCELL, 500 mm HIGH	2

### Gates

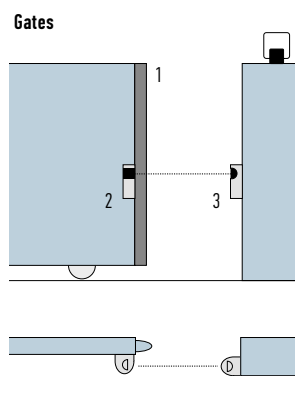

1. TCB65, RESISTIVE SENSITIVE EDGES
2. TX FT210 POWER SUPPLY WITH BATTERY
3. RX FT210.

# F210

BLUEBUS

**Synchronised photocells horizontally adjustable through 210° and 30° vertically. Simply perfect installations.**

### The 210° solution

The beam of the Nice F210 and F210B photocells has a horizontal scope of 210°, thereby increasing the safety level of the system and simplifying installation: the gate or garage door to be automated quite often slide flush with the wall making it very difficult to position the photocell.

### Numerous models and countless advantages

The new photocells are available with relay output (F210) or with the Nice BlueBUS technology (F210B).

With the BlueBUS technology, all devices can be easily connected to the control unit with just two wires.

Sensors with the BlueBUS technology can be connected to incompatible control units by means of an IB interface. The devices that are connected to the BlueBUS network are automatically acquired by the system.

### Suitable for any architectural environment and easy to install

Reduced dimensions: 46x128x45 mm; electrical connections can also be made from the lower section of the box.

### Resilient and safe

Polycarbonate casing; FA1 vandal-proof metal shell (optional).

### Cutting-edge technology

The problem of interference between the sensors and the automatic synchronisation between several pairs of photocells is solved by the anti-blinding circuit; high range adjustable on 2 levels; synchronising circuit; alignment with proportional LED for easy and safe installation.



F210, FA1



PPH2

PPH1

CODE	DESCRIPTION	PC/PACK
F210	PAIR OF SYNCHRONISED PHOTOCELLS ADJUSTABLE THROUGH 210°, WITH RELAY OUTPUT	1
F210B	PAIR OF SYNCHRONISED PHOTOCELLS ADJUSTABLE THROUGH 210°, WITH THE NICE BLUEBUS TECHNOLOGY	1

### TECHNICAL SPECIFICATIONS

	Estimated range (m)	Power supply	Absorption	Protection rating (IP)	Working temp. (°C Min/Max)	Range relè	Dimensions (mm)	Weight (g)
F210	10 (30 with jumper cut)	without jumper 24 Vac/Vdc limits: 18-35 Vdc, 15-28 Vac with jumper 12 Vac/Vdc limits: 10-18 Vdc, 9-15 Vac	25 mA RX, 30 mA TX	44	-20 ÷ +55	max 500 mA and 48 V	46x45x128 h	230
F210B		the device can only be connected to "BlueBUS" networks	1 BlueBUS unit					

### ACCESSORIES

CODE	DESCRIPTION	PC/PACK
IB	INTERFACE FOR CONNECTING BLUEBUS F210B PHOTOCELLS UP TO CONTROL UNITS WHICH HAVE NOT BEEN MANUFACTURED FOR THIS PURPOSE	1
FA1	VANDAL-PROOF METAL SHELL	2
FA2	BRACKET FOR FIXING TO PPH2 AND PPH1 COLUMNS	5
PPH2	ALUMINIUM POST FOR 2 PHOTOCELLS, 1000 mm HIGH	2
PPH1	ALUMINIUM POST FOR 1 PHOTOCCELL, 500 mm HIGH	2

### TECHNICAL SPECIFICATIONS

	Power supply	Current draw with 24 Vdc power supply	Current draw with 24 Vdc power supply	BlueBUS output	Protection rating (IP)	Working temp. (°C Min/Max)	Dimensions (mm)	Weight (g)
IB	16÷35 Vdc 18÷28 Vac	50 mA (add approx. 50 mA for each pair of photocells)	44 mA (add approx. 44 mA for each pair of photocells)	one with maximum load of 9 BlueBUS units	30	-20 ÷ +55	86x58x22 h	72



IB



FA1, FA2

# KIO

**KIO, key-operated selector switch for low voltage contacts, with release mechanism for metal cord,** ideal for the automation of sectional doors, folding doors and rolling gates.

**User-friendly:**

Kio is both a key-operated selector switch and a release device. Its design makes it very convenient and effortless to use, and easy to install anywhere thanks to its very narrow outline.

**Long-lasting:** Kio is made of cast aluminium, epoxy powder coated for greater durability.

**Easy:** LED allows you to locate the selector switch even in total darkness.

**More safety:** coded key.

Release device activated directly by opening the door or by the winding device.

**The very first product to incorporate the key-operated control and release motor functions.**



KIO



KA1

CODE	DESCRIPTION	PC/PACK
KIO	KEY-OPERATED SELECTOR SWITCH FOR LOW VOLTAGE CONTACTS, WITH RELEASE MECHANISM FOR METAL CORD	1
KA1	6 m CABLE RELEASE KIT FOR KIO	1

# KIOMINI

**KIOMINI, aluminium key switch with control and release mechanism for metal cord.**

**Practical:** KIOMINI is both a lever for the release mechanism for metal cord and a control mechanism for the direct or through a control unit activation of a single phase motor.

**Resistant:** a vandal-proof die-cast aluminium casing. The access to the sector is possible by a thick door with closing key.

**Comfortable:** thanks to its small dimensions, it is easy and compact to install.



CODE	DESCRIPTION	PC/PACK
KIOMINI	ALUMINIUM KEY SWITCH WITH CONTROL AND RELEASE MECHANISM	1



# HEATING DEVICE

**PW1, heating element:** it maintains a suitable temperature for the automation system to operate correctly, **even under the most severe of weather conditions.**

This is a particular type of **resistance** that can reach temperatures close to 100°C under normal environmental conditions.

**Effective:** each element has a consumption of 20 W and is extremely efficient thanks to the silicone sheath that covers the resistance and increases the diffusion of heat.

**Independent:** the device is directly fed by a 230/120 Vac power supply through the TW1 thermostat, and because it doesn't burden the transformer of the product itself, the performance characteristics of the gear motor remain the same.

## TW1, regulation thermostat for PW1:

when the detected temperature drops below the set threshold, the thermostat activates the heating element PW1 thereby slowly increasing the internal temperature of the product itself; the heating action is maintained until the detected surrounding temperature stabilizes at the set levels.

**Easy to program:** the intervention threshold can be regulated between 0°C and -20°C.

**Safe:** equipped with a button so that an operational test can be performed at any time. The status of the outputs is continuously verified by means of Leds.



PW1

TW1

CODE	DESCRIPTION	PC/PACK
<b>PW1</b>	HEATING ELEMENT FOR THE AUTOMATION SYSTEM	1
<b>TW1</b>	REGULATION THERMOSTAT	1

# CONTROL UNITS



# SELECTION GUIDE

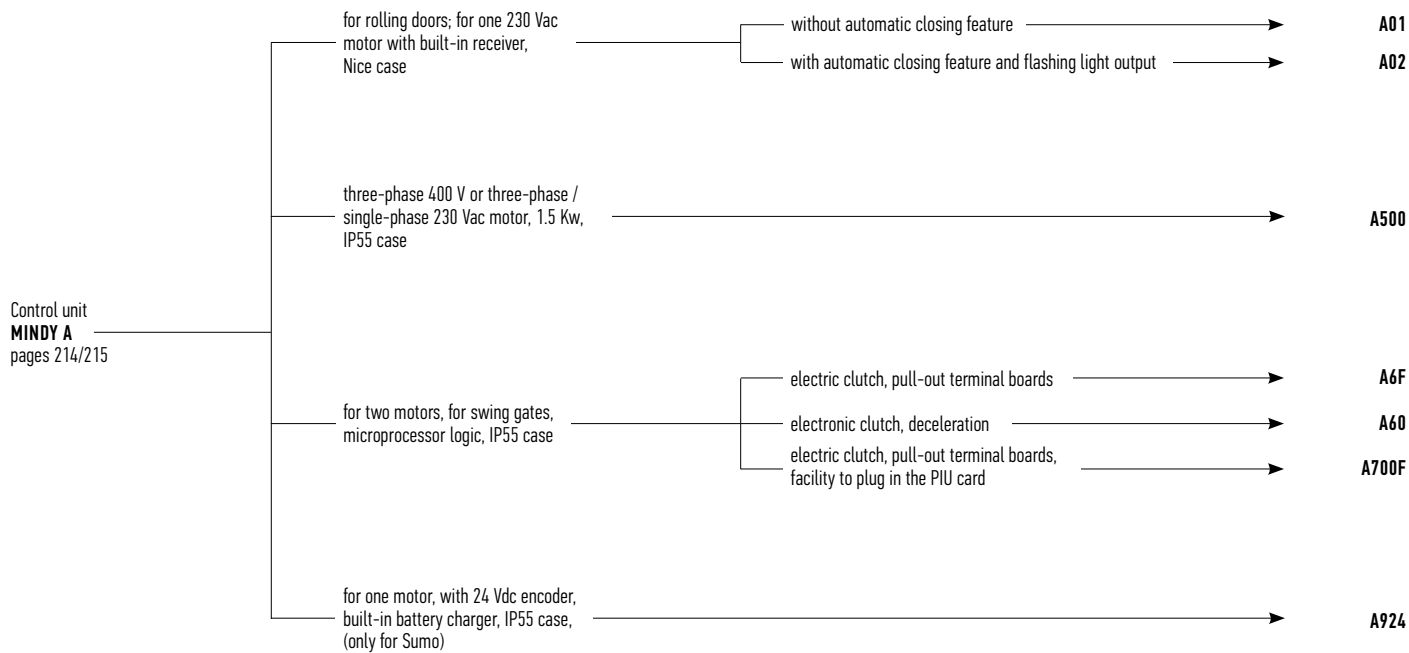
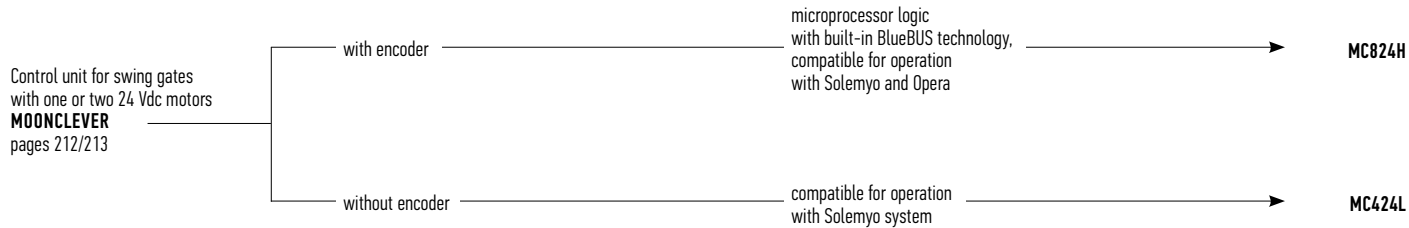

FOR SWING GATES

FOR SLIDING GATES

BARRIER GATE OPERATOR SYSTEMS

FOR GARAGE AND INDUSTRIAL DOORS

CONTROL SYSTEMS AND ACCESSORIES

COMPATIBILITY TABLE AND ALPHABETICAL INDEX

# MOONCLEVER

SOLEMYO OPERA BLUEBUS 24V

## Control unit for 24 Vdc gear motors with magnetic encoder, for swing gates.

Equipped with Nice **BlueBUS** technology and compatible with the **Solemyo** solar power system and **Opera** system for management, programming and diagnostics of automations, also remotely.

Compatible with the Opera system, which thanks to the O-View multi-function display enables personalisation of the system, modifying the opening and closing positions, leaf offset and deceleration intervals, and diversifying parameters such as force, speed, and obstacle detection for each motor.

Microprocessor logic: in addition to the classic functions such as intelligent clutch with anti-crushing safety device, gradual start-up and deceleration, automatic memorisation of both travel limit positions and the pedestrian door function, Moonclever also offers the advantages of the Opera system.

**Safe and reliable** thanks to obstacle detection with dual technology and monitoring of motor absorption and speed via the encoder, throughout door/gate travel, with provision for connection of latest generation resistive sensitive edges.

**Intelligent:** on start-up, indicator to confirm correct power supply and efficient operation of the control unit; automatic fault diagnostics and signalling via the flashing light and confirmation leds.

**Savings, respect for the environment, and autonomy:** when connected to the buffer battery or Solemyo kit, consumption on standby is reduced to just 0.1 W.

**Installation couldn't be simpler,** thanks to the system BlueBUS, enabling connection of the control unit, motors and accessories by means of just two wires.

**No black out:** operation in the event of a power failure by means of optional batteries (PS124) with compartment in control unit.

**Radio receiver:** provision for insertion of SM snap-fit receivers.



CODE	DESCRIPTION	PC/PACK
MC824H	CONTROL UNIT FOR ONE OR TWO MOTORS AT 24 Vdc WITH ENCODER, WITH BLUEBUS TECHNOLOGY, COMPATIBLE FOR OPERA AND SOLEMYO SYSTEMS	1

## TECHNICAL SPECIFICATIONS

CODE	MC824H
POWER SUPPLY (Vac 50/60HZ)	230 ± 10%
BATTERY POWER (Vdc)	21 ÷ 28
MAXIMUM MOTOR POWER (VA; A)	360 (W); 15
MAXIMUM ACCESSORIES POWER 24 V (A)	0.2
MAXIMUM FLASHING LIGHT POWER (V;W)	12; 21
MAXIMUM GATE OPEN INDICATOR POWER CA (V; W)	24; 2
MAXIMUM ELECTRIC LOCK POWER (Vac; VA)	12; 15
WORKING TIME "TL" (S)	-
PAUSE TIME "TP" (S)	1 ÷ 250
OPENING DELAY TIME TRA (S)	PROGRAMMABLE
CLOSING DELAY TIME TRC (S)	PROGRAMMABLE
COURTESY LIGHT TIME "TCOR" (S)	0:250
PRE-FLASHING TIME "TPRE" (S)	0:10
FORCE ADJUSTMENT (%)	-
ANTI-CRUSHING DEVICE (SENSITIVITY)	MIN ÷ MAX
CASE DIMENSIONS (mm)	230x125x300 h



## ACCESSORIES



**MCA1**  
SPARE CONTROL UNIT  
FOR MC824H.  
PC/PACK 1



**PS324**  
24 V BATTERY  
WITH INTEGRATED  
BATTERY CHARGER.  
PC/PACK 1

# MOONCLEVER

SOLEMYO 24V

**Control unit for 24 Vdc gear motors for swing gates, without encoder.**

Compatible with the solar power kit **Solemyo**.

**Safe and reliable** thanks to obstacle detection throughout travel and provision for the connection of latest generation resistive sensitive edges.

**Intelligent:** automatic fault diagnostics and signals via flashing light and confirmation leds.

**Savings, respect for the environment, ad autonomy:** connected to the buffer battery or Solemyo kit, consumption on standby is just 0.1 W.

**No black out:** operation in the event of a power failure by means of optional batteries (PS124) with compartment in control unit.

**Radio receiver:** provision for insertion of SM snap-fit receivers.



CODE	DESCRIPTION	PC/PACK
MC424L	CONTROL UNIT FOR ONE OR TWO MOTORS AT 24 Vdc WITHOUT ENCODER, COMPATIBLE FOR SOLEMYO SYSTEM	1

## TECHNICAL SPECIFICATIONS

CODE	MC424L
POWER SUPPLY (Vac 50/60HZ)	230 ± 10%
BATTERY POWER (Vdc)	21 ÷ 28
MAXIMUM MOTOR POWER (VA; A)	75; 3
MAXIMUM ACCESSORIES POWER 24 V (A)	0.2 +0.1
MAXIMUM FLASHING LIGHT POWER (V;W)	24; 25
MAXIMUM GATE OPEN INDICATOR POWER CA (V; W)	24; 2
MAXIMUM ELECTRIC LOCK POWER (Vac; VA)	12; 15
WORKING TIME "TL" (S)	-
PAUSE TIME "TP" (S)	5 ÷ 80
OPENING DELAY TIME TRA (S)	5 ÷ 40% TL
CLOSING DELAY TIME TRC (S)	-
COURTESY LIGHT TIME "TCOR" (S)	-
PRE-FLASHING TIME "TPRE" (S)	3
FORCE ADJUSTMENT (%)	-
ANTI-CRUSHING DEVICE (SENSITIVITY)	1 ÷ 6
CASE DIMENSIONS (mm)	230x125x300 h



MC424L

## ACCESSORIES



**MCA2**  
SPARE CONTROL UNIT  
FOR MC424L.  
PC/PACK 1



**PS124**  
24 V BATTERY  
WITH INTEGRATED  
BATTERY CHARGER.  
PC/PACK 1

FOR SWING GATES

FOR SLIDING GATES

BARRIER GATE  
OPERATOR SYSTEMS

FOR GARAGE  
AND INDUSTRIAL DOORS

CONTROL SYSTEMS  
AND ACCESSORIES

COMPATIBILITY TABLE  
AND ALPHABETICAL INDEX

# MINDY A01, A02

## Mindy A01, A02 control units for rolling doors.

**Incorporated radio card** compatible with the Nice Flo, FloR and Smilo systems.

**Programmable Step-by-step/Open** input.

Input for **close** function.

Input for connection interface for 8.2 KOhm resistive sensitive edge.

Semi-automatic and automatic operation.

Flashing light output (A02 model).



CODE	DESCRIPTION	PC/PACK
<b>A01</b>	FOR ONE 230 Vac MOTOR, FOR ROLLING SHUTTERS, WITHOUT AUTOMATIC CLOSING FEATURE, WITH BUILT-IN RECEIVER COMPATIBLE WITH THE FLO, FLOR AND SMILO SERIES OF TRANSMITTERS	1
<b>A02</b>	FOR ONE 230 Vac MOTOR, FOR ROLLING SHUTTERS, WITH SEMI-AUTOMATIC AND AUTOMATIC CLOSING FEATURE, FLASHING LIGHT OUTPUT AND WITH BUILT-IN RECEIVER COMPATIBLE WITH THE FLO, FLOR AND SMILO SERIES OF TRANSMITTERS	1

### TECHNICAL SPECIFICATIONS

CODE	A01	A02
POWER SUPPLY (Vac 50/60 Hz)	230 ± 10%	
BATTERY POWER (Vdc)	-	
MAXIMUM MOTOR POWER (VA; A)	900; 5	
MAXIMUM ACCESSORIES POWER 24 V (A)	0.055	
MAXIMUM FLASHING LIGHT POWER (V;W)	-	230; 40
MAXIMUM GATE OPEN INDICATOR POWER CA (V; W)	-	
MAXIMUM ELECTRIC LOCK POWER (V; W)	-	
WORKING TIME "TL" (S)	5 ÷ 120	
PAUSE TIME "TP" (S)	-	1 ÷ 120
OPENING DELAY TIME TRA (S)	-	
CLOSING DELAY TIME TRC (S)	-	
COURTESY LIGHT TIME "TCOR" (S)	-	
PRE-FLASHING TIME "TPRE" (S)	-	
FORCE ADJUSTMENT (%)	-	
ANTI-CRUSHING DEVICE (SENSITIVITY)	-	
CASE DIMENSIONS (mm)	128x112x43 h	

# MINDY A500

## Mindy A500 control unit, three-phase 230 V, 400 V or single-phase 230 Vac motor, 1.5 Kw.

Automatic detection of obstacles, door block, brake.

Pull-out terminal boards.



PUL



CODE	DESCRIPTION	PC/PACK
<b>A500</b>	FOR A THREE-PHASE 400 Vac OR SINGLE-PHASE / THREE PHASE 230 Vac MOTOR, 1.5 KW	1
<b>PIU</b>	EXPANSION CARD FOR ADDITIONAL FUNCTIONS	1
<b>PUL</b>	CENTRAL COVER WITH INCORPORATED CONTROL BUTTONS, COMPLETE WITH CONNECTING CABLE AND CONNECTOR FOR A500 AND A924	1

### TECHNICAL SPECIFICATIONS

CODE	A500
POWER SUPPLY (Vac 50/60 Hz)	400/230 ± 10%
BATTERY POWER (Vdc)	-
MAXIMUM MOTOR POWER (VA; A)	1500; 4
MAXIMUM ACCESSORIES POWER 24 V (A)	0.2 + 0.2
MAXIMUM FLASHING LIGHT POWER (V;W)	230; 40
MAXIMUM GATE OPEN INDICATOR POWER CA (V; W)	24.2
MAXIMUM ELECTRIC LOCK POWER (V; W)	-
WORKING TIME "TL" (S)	3 ÷ 120 (210)
PAUSE TIME "TP" (S)	5 ÷ 200
OPENING DELAY TIME TRA (S)	-
CLOSING DELAY TIME TRC (S)	-
COURTESY LIGHT TIME "TCOR" (S)	(PIU)
PRE-FLASHING TIME "TPRE" (S)	5
FORCE ADJUSTMENT (%)	-
ANTI-CRUSHING DEVICE (SENSITIVITY)	MIN ÷ MAX
CASE DIMENSIONS (mm)	220x110x280 h

# MINDY A6F, A60, A700F

## Mindy A6F, A60 control units, for two motors; microprocessor logic.

Pull-out terminal boards (A6F and A60 models).  
Two photocell inputs with separate functions.  
Electrical (A6F model) or electronic (A6F and A60 models) adjustment.  
Gradual departure and slowdown (A60).  
Adjustment is separate to the work times (A60).



PUL

## Mindy A700F control unit, for two motors; microprocessor logic.

Removable terminal boards; two photocell inputs; four limit switch inputs; partial opening (standard).  
Unbeatable performance due to the many programmable functions.

PIU expansion card can be inserted to provide more functions.



CODE	DESCRIPTION	PC/PACK
<b>A6F</b>	FOR TWO 230 Vac MOTORS WITH ELECTRIC CLUTCH, IP55 CASE	1
<b>A60</b>	FOR TWO 230 Vac MOTORS WITH ELECTRONIC CLUTCH AND SLOWDOWN, IP55 CASING	1
<b>A700F</b>	FOR TWO 230 Vac MOTORS WITH ELECTRIC CLUTCH. POSSIBILITY OF ADDING THE PIU EXPANSION CARD, IP55 CASE	1
<b>PIU</b>	EXPANSION CARD FOR ADDITIONAL FUNCTIONS	1
<b>PUL</b>	CENTRAL COVER WITH INCORPORATED CONTROL BUTTONS, COMPLETE WITH CONNECTING CABLE AND CONNECTOR FOR A500 AND A924	1

### TECHNICAL SPECIFICATIONS

CODE	A6F	A60	A700F
POWER SUPPLY (Vac 50/60 Hz)	230 ± 10%		
BATTERY POWER (Vdc)	-		
MAXIMUM MOTOR POWER (VA; A)	2x400; 2		
MAXIMUM ACCESSORIES POWER 24 V (A)	0.3	0.2 + 0.075	0.2 + 0.1
MAXIMUM FLASHING LIGHT POWER (V; W)	230; 100	230; 40	230; 100
MAXIMUM GATE OPEN INDICATOR POWER CA (V; W)	24; 2		
MAXIMUM ELECTRIC LOCK POWER (V; W)	12; 25		
WORKING TIME "TL" (S)	2.5 ÷ 40 (80)		
PAUSE TIME "TP" (S)	5 ÷ 80		
OPENING DELAY TIME TRA (S)	0/2.5 ÷ 12		
CLOSING DELAY TIME TRC (S)	0/2.5 ÷ 12		
COURTESY LIGHT TIME "TCOR" (S)	60	60 (PIU)	
PRE-FLASHING TIME "TPRE" (S)	5		
FORCE ADJUSTMENT (%)	30/45/60/ 80/100	0 ÷ 100	30/45/60/80/100
ANTI-CRUSHING DEVICE (SENSITIVITY)	-		
CASE DIMENSIONS (mm)	220x110x280 h		

# MINDY A924

## Mindy A924 control units (only for Sumo)

24 V version for one dc motor, complete with encoder.  
Intelligent clutch with anti-crush safety feature.  
Automatic memorization of limit switches on opening and closing; gradual departure and slowdown.  
Pedestrian passage function "service".  
Warning light for maintenance (can be programmed).  
Built-in battery charger. Pull-out terminal boards.



PUL



CODE	DESCRIPTION	PC/PACK
<b>A924</b>	FOR ONE MOTOR, WITH 24 Vdc ENCODER, BUILT-IN BATTERY CHARGER, IP55 CASE (ONLY FOR SUMO)	1
<b>B12-B</b>	12 V, 6 Ah BATTERIES	1
<b>B12V-C</b>	12 V, 2 Ah BATTERIES	1
<b>CARICA</b>	PLUG-IN CARD FOR BATTERY CHARGER	1
<b>BA3-A</b>	NICE BATTERY BOX FOR A924	1
<b>PUL</b>	CENTRAL COVER WITH INCORPORATED CONTROL BUTTONS, COMPLETE WITH CONNECTING CABLE AND CONNECTOR FOR A500 AND A924	1

### TECHNICAL SPECIFICATIONS

CODE	A924
POWER SUPPLY (Vac 50/60 Hz)	230 ± 10%
BATTERY POWER (Vdc)	21 ÷ 28
MAXIMUM MOTOR POWER (VA; A)	360 (W); 15
MAXIMUM ACCESSORIES POWER 24 V (A)	0.2 + 0.2
MAXIMUM FLASHING LIGHT POWER (V; W)	24/25
MAXIMUM GATE OPEN INDICATOR POWER CA (V; W)	24; 2
MAXIMUM ELECTRIC LOCK POWER (V; W)	24; 12
WORKING TIME "TL" (S) / PAUSE TIME "TP" (S)	- / 1 ÷ 1023
OPENING DELAY TIME TRA (S)	-
CLOSING DELAY TIME TRC (S)	-
COURTESY LIGHT TIME "TCOR" (S)	60
PRE-FLASHING TIME "TPRE" (S)	5
FORCE ADJUSTMENT (%)	-
ANTI-CRUSHING DEVICE (SENSITIVITY)	MIN ÷ MAX
CASE DIMENSIONS (mm)	220x110x280 h

# CONTROL UNIT FUNCTIONS

## PROGRAMMABLE FUNCTIONS

	A01	A02	A500	A6/AGF	A60	A700F	A724	MC824H/HK7024	MC424L	WALKY	H02124	ROAD	ROBUS 350	ROBUS 600/1000/NAKED/SLIGHT/ROBUS HS	RUN/RUN HS	SPIN10	SPIN20/21/22KCE	SPIN23	SPIN30/SN6031	SPIN40/SN6041	TN2030/TNKCE	S00N/TN2010	M-BAR/L-BAR	S-BAR	WIDE	
Manual operation																										
Semi-automatic operation																										
Automatic operation																										
Automatic operation + always close																										
Condominium operation																										
Pre-flashing																										
Close again 5 s after Photo																										
Photo during opening, too																										
Gradual departure																										
Gradual stop																										
Flashing even during the Pause																										
Courtesy light "on" Flashing light																										
Impulsive courtesy light																										
Gate open light (CA) with proportional flashing																										
Cancel stop during the Step-by Step cycle																										
Photocell safety when each movement starts																										
Automatic realignment when power supply returns																										
Positioning function																										
Hammering								5																		
Maintaining the pressure on oil-pressure motors																										
Activation of the Phototest																										
Skip STOP during opening																										
Skip STOP during closing																										
CLOSE becomes PEDESTRIAN OPEN																										
Photocells (PHOTO and/or PHOTO1) during opening too																										
Partial remote controlled inversion with PHOTO photocell																										
Complete remote controlled inversion with PHOTO photocell																										
Exclude limit switch																										
Standard Step-by-Step function: Open-Close-Open																										
Mode 2 Step-by-Step function: Open-Pause-Close-Open																										
Mode 3 Step-by-Step function: Open-Stop-Close-Open																										

## PROGRAMMABLE FUNCTIONS

	A01	A02	A500	A6/AGF	A60	A700F	A724	MC824H/HK7024	MC424L	WALKY	H02124	ROAD	ROBUS 350	ROBUS 600/1000/NAKED/SLIGHT/ROBUS HS	RUN/RUN HS	SPIN10	SPIN20/21/22KCE	SPIN23	SPIN30/SN6031	SPIN40/SN6041	TN2030/TNKCE	S00N/TN2010	M-BAR/L-BAR	S-BAR	WIDE	
Temporary pause (photocell)																										
Gate open light (CA) becomes "one way" traffic lights																										
Two way traffic lights																										
Step-by-Step function Open-Stop-Close-Stop																										
Extension of work time																										
Pause time with presence detector																										
1 <sup>st</sup> motor delay during opening																										
Gate Open light with limit switch																										
Brake																										
Radio card incorporated in the control unit																										
Stand-by																										





# CONNECTIONS

## WALKY

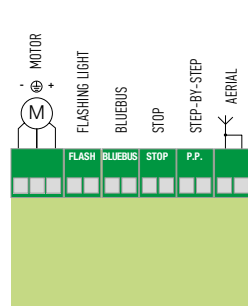

## HOPP 7124

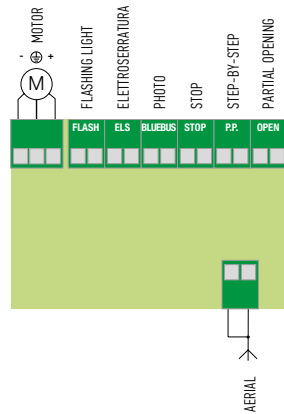

## ROBUS 400/600/1000

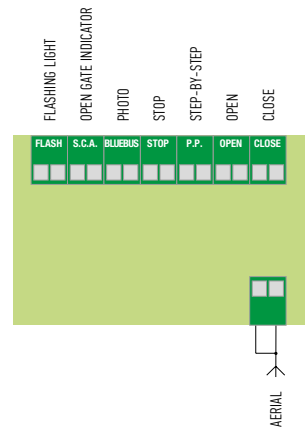

## ROAD

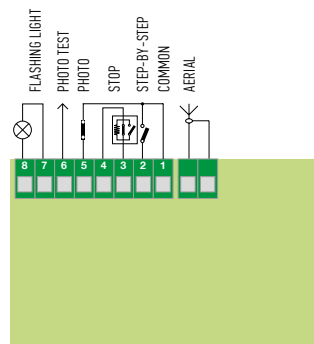

## RUN/RUN HS

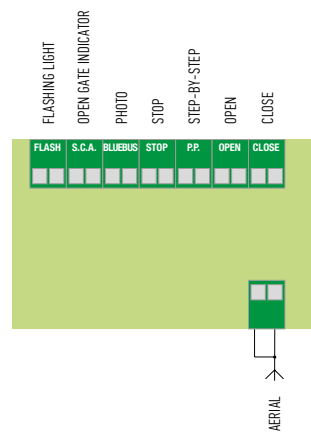

## SLIGHT/NAKED SLIDING 400/ROBUS HS

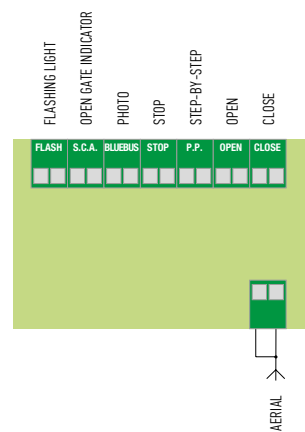

## L-BAR/M-BAR

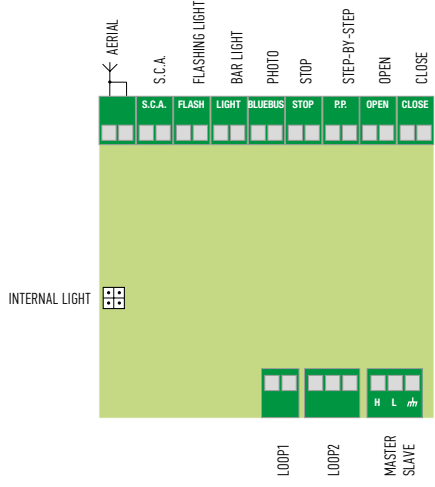

## S-BAR

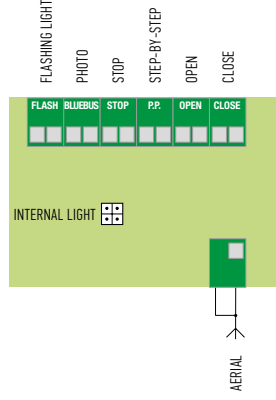

## WIDE

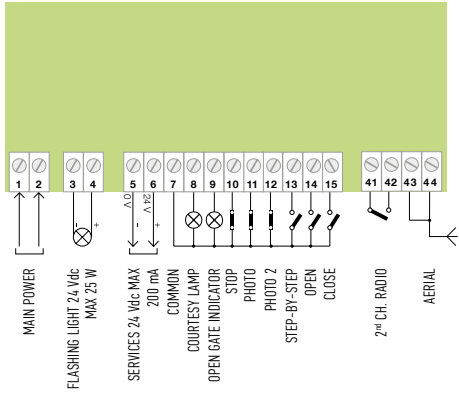

# CONNECTIONS

SPIN20KCE/SPIN21KCE/SPIN22KCE

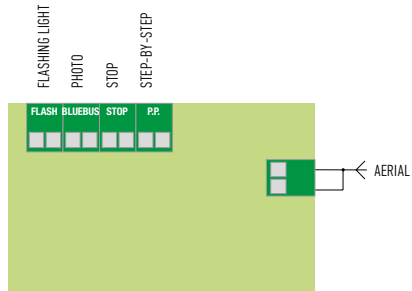

SPIN23KCE/SPIN30/SN6031/SPIN40/SN6041

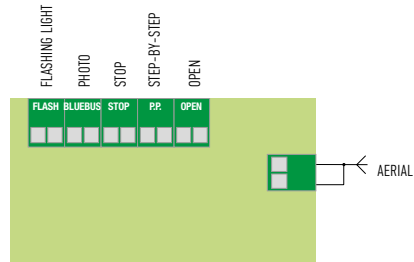

SPIN10KCE/SPIN11KCE

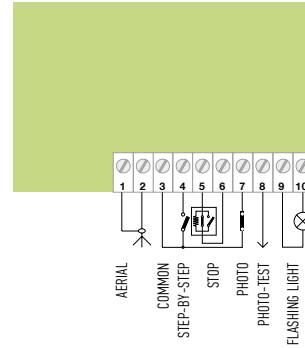

TN2010

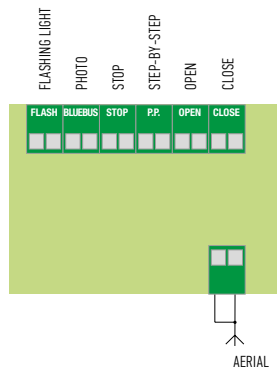

TN2030/TNKCE

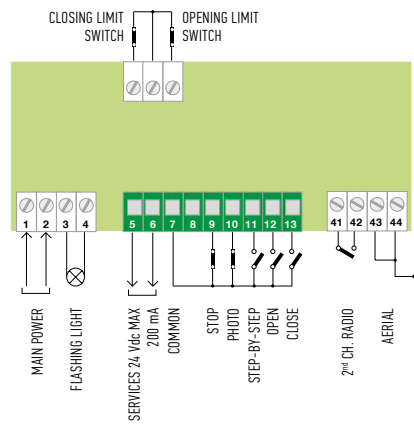

SOON

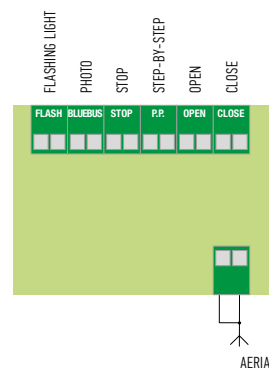

TTX4

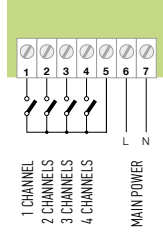

TT2N

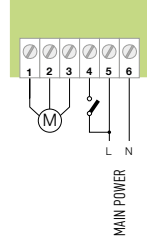

TT2L

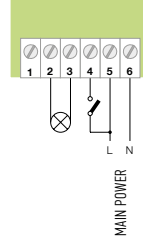

TT2D

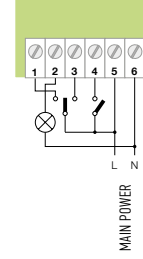

TT1N

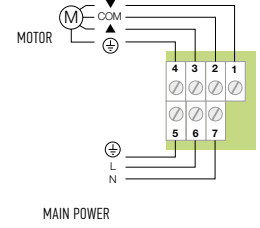

TT1L

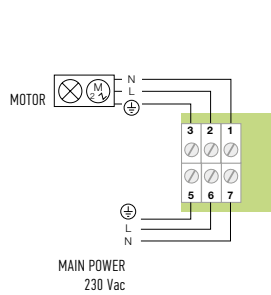

MC824H/HYKE

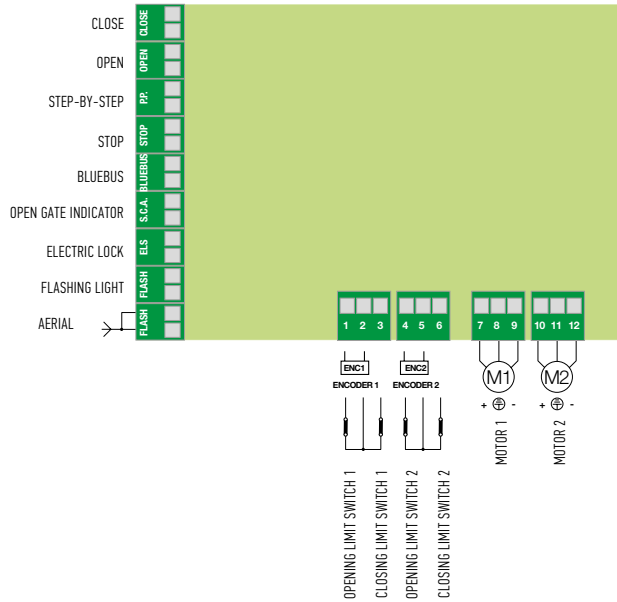

MC424L

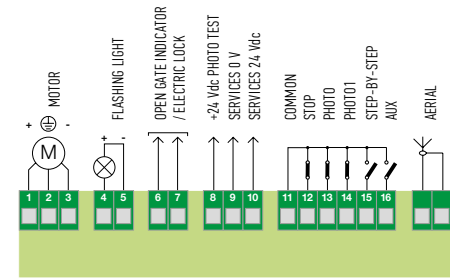

# CONNECTIONS

A0

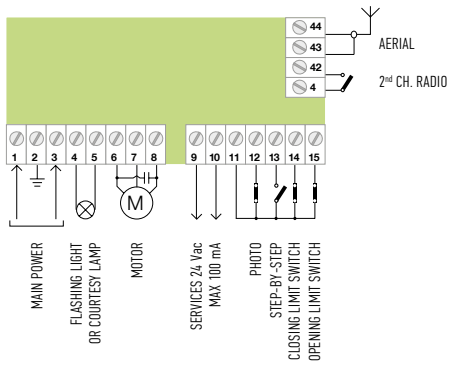

A01

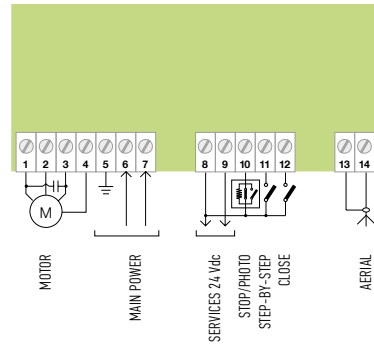

A02

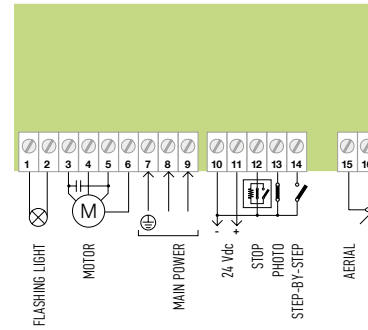

A1

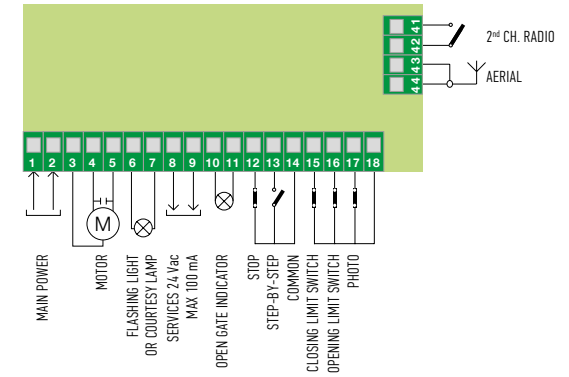

A400

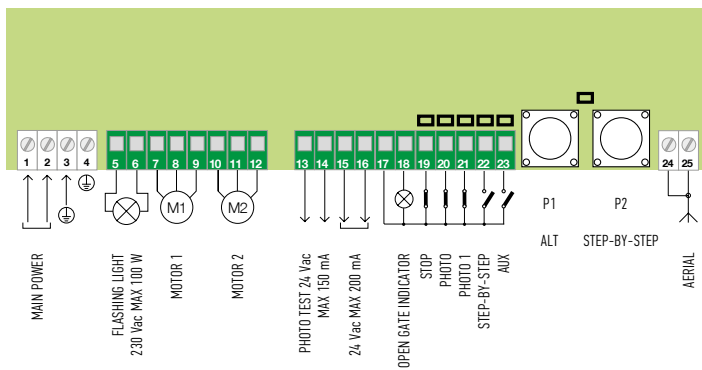

A500

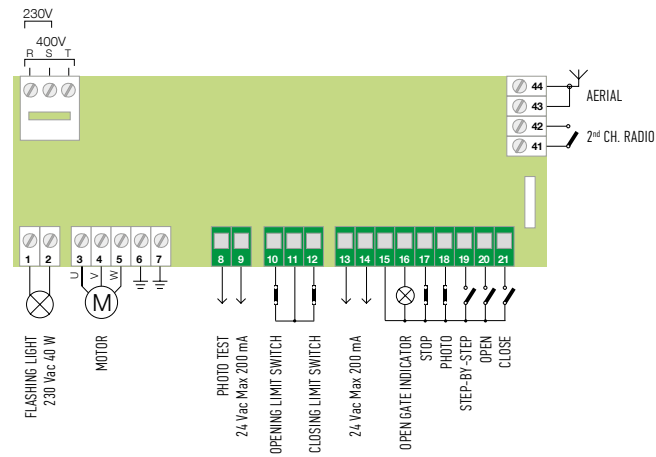

A60

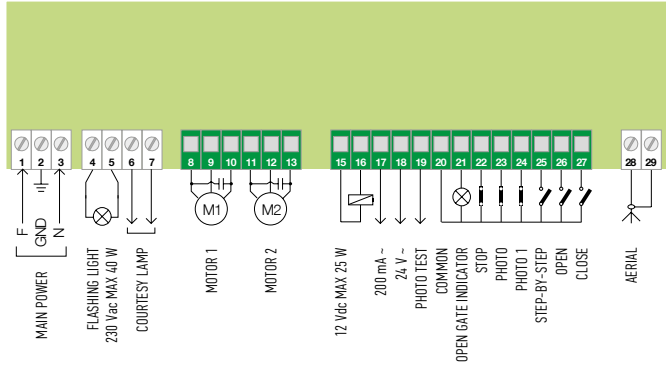

A6/A6F, A700F

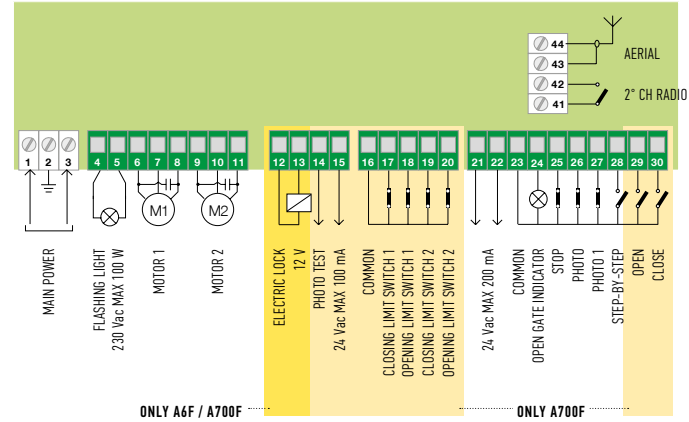

A824

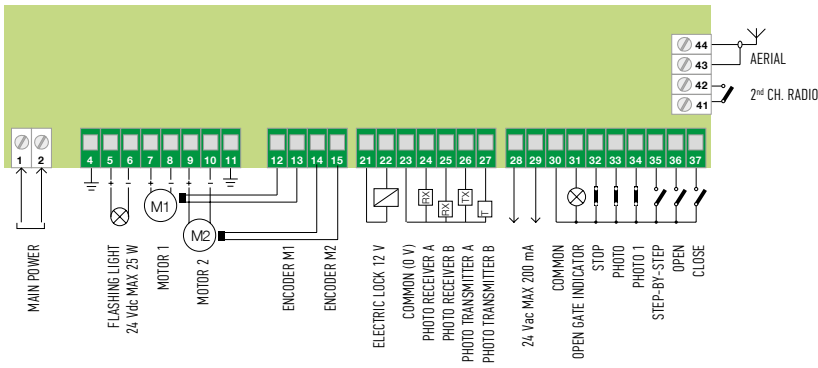

A924

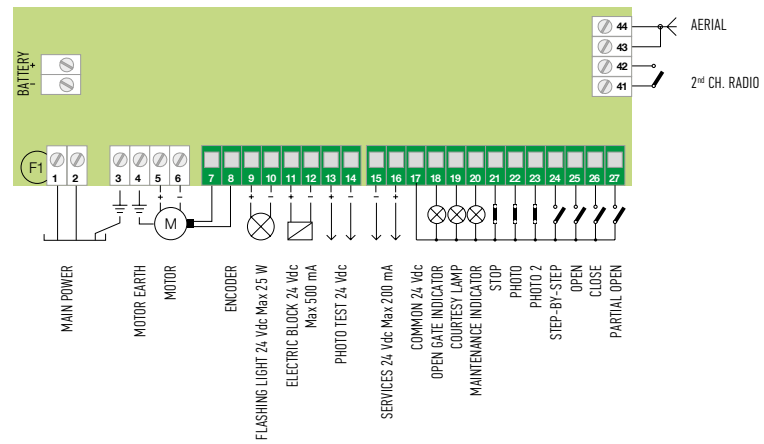

FOR SWING GATES

FOR SLIDING GATES

BARRIER GATE OPERATOR SYSTEMS

FOR GARAGE AND INDUSTRIAL DOORS

CONTROL SYSTEMS AND ACCESSORIES

COMPATIBILITY TABLE AND ALPHABETICAL INDEX

A NICE DAY  
TOGETHER

TECHNICAL  
WORKSHOP  
FOR GATE & DOOR INSTALLERS





# NICE SERVICE FOR YOU

## NICE SERVICE FOR YOU: QUALITY, SAFETY AND LONG LIFE

THE CARE OF THE PRODUCT AND TO THE EUROPEAN STANDARDS IN ORDER TO GUARANTEE THE SAFETY OF YOUR AUTOMATION.

### NICE INFORMS

To reinforce the company's relationship with professionals and provide serious and complete training, **Nice offers a packed program of training courses on products, installation techniques, programming and updates.**

Particular attention and exhaustive coverage is dedicated to current European legislation and standards, with the aim of simplifying the procedure to obtain the declaration of conformity and guarantee the complete safety of the automation systems installed.

## THE NICE EFFORT FOR CUSTOMERS AND AUTOMATION PROFESSIONALS

### AFTER-SALES SERVICE

Nice guarantees an **efficient and punctual service**, including on-line: every Nice customer can surf on the new website [www.niceforyou.com](http://www.niceforyou.com) and consult all documentation on products and spare parts, together with constantly up-to-date technical information and the possibility to download installation manuals.



# COMPATIBILITY GUIDE FOR AUTOMATION SYSTEMS

## SYSTEMS FOR SWING GATES

MOTOR	MOONCLEVER CONTROL UNIT	SPARE CODE	RECEIVER	TRANSMITTER	PHOTOCELLS	FLASHING LIGHT				
WG4024, WG5024, WG2024, WG3524	MC424L	SOLEMYO 24V	MCA2	OXI	ERA INTI, ERA ONE, ERA FLOR, NICEWAY FLOR-S, FLOR-M, FLO, ONE, SMILO, VERY VR, VERY VE	EPS, EPM, EPL F210, FT210 MOF, BF, FK, FE, FI	EL24 ML24, ML24T LUCY24			
XFAB2024						MCA1	OXI	ERA INTI, ERA ONE, ERA FLOR, NICEWAY FLOR-S, FLOR-M, FLO, ONE, SMILO, VERY VR, VERY VE	EPSB, EPMB, EPLB F210B MOFB	ELB WLT MLB, MLBT
T003024, T004524 <i>(only in MC424LR01)</i>										
T04024, T05024, T07024 + T05024I										
HY7024, HY7124										
XFAB2124										
T06024HS, T05024HS										
MFAB3024HS, MFAB3024										
WG3524HS	MC824H	SOLEMYO OPERA BLUEBUS 24V	MCA1	OXI	ERA INTI, ERA ONE, ERA FLOR, NICEWAY FLOR-S, FLOR-M, FLO, ONE, SMILO, VERY VR, VERY VE	EPSB, EPMB, EPLB F210B MOFB	ELB WLT MLB, MLBT			
LFAB4024										
BFAB5024										
T05624I	MC824HR	SOLEMYO OPERA BLUEBUS 24V	MCA3	OXI	ERA INTI, ERA ONE, ERA FLOR, NICEWAY FLOR-S, FLOR-M, FLO, ONE, SMILO, VERY VR, VERY VE	EPSB, EPMB, EPLB F210B, MOFB	ELB, WLT MLB, MLBT			
MOTOR WITH ARTICULATED ARM	BUILT-IN CONTROL UNIT / SPARE CODE	RECEIVER	TRANSMITTER	PHOTOCELLS	FLASHING LIGHT					
PP7024	POA1	24V	OXI	ERA INTI, ERA ONE, ERA FLOR, NICEWAY FLOR-S, FLOR-M, FLO, ONE, SMILO, VERY VR, VERY VE	EPS, EPM, EPL MOF, BF, FK, FE, FI	EL24, ML24, ML24T, LUCY24				
WL1024C	WLA1	SOLEMYO OPERA BLUEBUS 24V			EPSB, EPMB, EPLB F210B, MOFB	ELB, WLT MLB, MLBT				
H07124, PP7124	POA3	SOLEMYO OPERA BLUEBUS 24V								
HK7024, HK7024HS	HKA1	SOLEMYO OPERA BLUEBUS 24V								

■ CODE INCLUDED IN THE GATE&DOOR CATALOGUE 2016

■ CODE NOT INCLUDED IN THE CATALOGUE

# SYSTEMS FOR SLIDING GATES

MOTOR	BUILT-IN CONTROL UNIT / SPARE CODE		RECEIVER	TRANSMITTER	PHOTOCELLS	FLASHING LIGHT
R0300	ROA34		OXI	ERA INTI, ERA ONE, ERA FLOR, NICEWAY, FLOR-S, FLOR-M, FLO, ONE, SMILO, VERY VR, VERY VE	EPS, EPM, EPL F210, FT210 MOF, BF, FK, FE, FI	ML, MLT, LUCY, LL
R01000, R01020	ROA3		FLOXIR, FLOXI2R*	ERA INTI, ERA ONE, ERA FLOR, NICEWAY, FLOR-S, FLOR-M, ONE, VERY VR		EL24, ML24, ML24T
R01010	ROA4					
R01124	ROA2	24V	Built-in*	ERA INTI, ERA ONE, ERA FLOR, NICEWAY, FLOR-S, FLOR-M, FLO, ONE, SMILO, ERGO, PLANO, VERY VR		ML, MLT, LUCY, LL
R0500, R01070, TH1500	ROA37					
TH1551	THA5		FLOXIR, FLOXI2R*	ERA INTI, ERA ONE, ERA FLOR, NICEWAY, FLOR-S, FLOR-M, ONE, VERY VR		ML, MLT, LUCY, LL
TH2251	THA6		FLOXIR, FLOXI2R*			
RD400	RBA4	24V	Built-in*	ERA INTI, ERA ONE, ERA FLOR, NICEWAY, FLOR-S, FLOR-M, FLO, ONE, SMILO, VERY VR, VERY VE		EPSB, EPMB, EPLB F210B MOFB
RB350	RBA2	BLUEBUS 24V	OXI	ERA INTI, ERA ONE, ERA FLOR, NICEWAY, FLOR-S, FLOR-M, FLO, ONE, SMILO, VERY VR, VERY VE		
NKSL400	NKA3	SOLEMYO OPERA BLUEBUS 24V		ERA INTI, ERA ONE, ERA FLOR, NICEWAY FLOR-S, FLOR-M, FLO, ONE, SMILO, VERY VR, VERY VE		
SLH400						
RB400	RBA3	SOLEMYO OPERA BLUEBUS 24V				
RB600						
RB1000						
RUN1500						
RUN1800	RUA1	OPERA BLUEBUS 230V				
RUN2500	RUA2 + RUA3	OPERA BLUEBUS 230V				
RUN2500I						
RB250HS, RB500HS	RBA3/HS	SOLEMYO OPERA BLUEBUS 24V				
RUN400HS, RUN1200HS	RUA6	OPERA BLUEBUS 24V				
TUB3500	MINDY A500		FLOXIR, FLOXI2R*	ERA INTI, ERA ONE, ERA FLOR, NICEWAY FLOR-S, FLOR-M, ONE, VERY VR	EPS, EPM, EPL F210, FT210 MOF, BF, FK, FE, FI	EL ML, MLT, LUCY
			FLOXI	FLO, VERY VE		

\*Radio receiver incompatible with Opera system

FOR SWING GATES

FOR SLIDING GATES

BARRIER GATE  
OPERATOR SYSTEMS

FOR GARAGE  
AND INDUSTRIAL DOORS

CONTROL SYSTEMS  
AND ACCESSORIES

COMPATIBILITY TABLE  
AND ALPHABETICAL INDEX

# COMPATIBILITY GUIDE FOR AUTOMATION SYSTEMS

## SYSTEMS FOR GARAGE DOORS

	MOTOR	BUILT-IN CONTROL UNIT / SPARE CODE	RECEIVER	TRANSMITTER	PHOTOCELLS	FLASHING LIGHT
SECTIONAL DOORS	SP6000	SPA40 24V	OXI	ERA INTI, ERA ONE, ERA FLOR, NICEWAY, FLOR-S, FLOR-M, FLO, ONE, SMILO, VERY VR, VERY VE	EPS, EPM, EPL F210, FT210 MOF, BF, FK, FE, FI	EL24, ML24, ML24T
	SP6065	SPA20 24V	FLOXI2R*, FLOXIR	ERA INTI, ERA ONE, ERA FLOR, NICEWAY, FLOR-S, FLOR-M, ONE, VERY VR		
			FLOXI	FLO, VERY VE		
	SP6100	SPA30 24V	FLOXI2R*, FLOXIR	ERA INTI, ERA ONE, ERA FLOR, NICEWAY, FLOR-S, FLOR-M, ONE, VERY VR		
			FLOXI	FLO, VERY VE		
	CR2124	ROA2 24V	FLOXI2R*, FLOXIR	ERA INTI, ERA ONE, ERA FLOR, NICEWAY, FLOR-S, FLOR-M, ONE, VERY VR		
			FLOXI	FLO, VERY VE		
	SN6011	SNA1 24V	Built-in*	ERA INTI, ERA ONE, ERA FLOR, NICEWAY, FLOR-S, FLOR-M, FLO, ONE, SMILO, VERY VR, VERY VE	EPSB, EPMB, EPLB, F210B, MOFB	ELB, WLT MLB, MLBT LUCYB
	SN6021	SNA2 BLUEBUS 24V	OXI	ERA INTI, ERA ONE, ERA FLOR, NICEWAY, FLOR-S, FLOR-M, FLO, ONE, SMILO, VERY VR, VERY VE		
	SN6023	SNA20 SOLEMYO OPERA BLUEBUS 24V				
	SN6031, SPIN30	SNA3 SOLEMYO OPERA BLUEBUS 24V				
	SN6041, SPIN40	SNA4 SOLEMYO OPERA BLUEBUS 24V				
SO2000	SOA2 SOLEMYO OPERA BLUEBUS 24V					
SHEL75KCE, SHEL50KCE	OGA0 24V	Built-in*		EPS, EPM, EPL, F210, FT210, MOF, BF, FK, FE, FI	-	
SPY650, SPY800	SPIBOX B SOLEMYO OPERA BLUEBUS 24V	OXI + Built-in*		EPSB, EPMB, EPLB, F210B, FT210B, MOFB	ELB, WLT MLB, MLBT LUCYB	
SPY550	SPYBOX OPERA 24V	Built-in	ERA INTI, ERA ONE, ERA FLOR, NICEWAY, FLOR-S, FLOR-M, ONE, VERY VR	EPS, EPM, EPL, F210, FT210, MOF, BF, FK, FE, FI	ELB, WLT MLB, MLBT LUCYB	
UP-AND-OVER DOORS	OT21, OT21FC	OTA1 24V	FLOXI2R*, FLOXIR	ERA INTI, ERA ONE, ERA FLOR, NICEWAY, FLOR-S, FLOR-M, ONE, VERY VR	EPS, EPM, EPL, F210, FT210 MOF, BF, FK	EL, ML, MLT, LUCY
			FLOXI	FLO, VERY VE		
	TN2010L, TN2010	TNA2 SOLEMYO OPERA BLUEBUS 24V	OXI	ERA INTI, ERA ONE, ERA FLOR, NICEWAY, FLOR-S, FLOR-M, FLO, ONE, SMILO, VERY VR, VERY VE	EPSB, EPMB, EPLB- F210B, FT210B, MOFB	ELB, WLT MLB, MLBT
TN2030L, TN2030 TNLKCE, TNKCE	TNA1 24V		EPS, EPM, EPL, F210, FT210, MOF, BF, FK, FE, FI			

\*Radio receiver incompatible with Opera system

## BARRIER GATE OPERATOR SYSTEMS

MOTOR	BUILT-IN CONTROL UNIT / SPARE CODE		RECEIVER	TRANSMITTER	PHOTOCELLS	FLASHING LIGHT
WIL	WA20	24V	OXI	ERA INTI, ERA ONE, ERA FLOR, NICEWAY, FLOR-S, FLOR-M, FLO, ONE, SMILO, VERY VR, VERY VE	EPS, EPM, EPL, F210, FT210 MOF, BF, FK, FE, FI	EL24 ML24, ML24T
WIDE	WY20	24V				
SIGNO <i>all models</i>	SIA20	24V				
XBAR	XBA2	24V				
SBAR	XBA20	SOLEMYO OPERA BLUEBUS 24V				
MBAR	XBA3	SOLEMYO OPERA BLUEBUS 24V				
LBAR						
					EPSB, EPMB, EPLB- F210B, FT210B MOFB	ELB, WLT MLB, MLBT

WIL barriers produced before 2008 have MOLEX radio plug

## SYSTEMS FOR GATES AND GARAGE DOORS WITH MINDY CONTROL UNITS

CONTROL UNIT	SPARE CODE	MOTOR	RECEIVER	TRANSMITTER	PHOTOCELLS	FLASHING LIGHT
A01	139-B.8001	GR170, GR340, RN2030, RN2040, RN2010, RN2020	Built-in*	ERA INTI, ERA ONE, ERA FLOR, NICEWAY FLOR-S, FLOR-M, FLO, ONE, SMILO, ERGO, PLANO, VERY VR, VERY VE	EPS, EPM, EPL F210, FT210 MOF, BF, FK, FE, FI	-
A02	200-A.8001					EL, ML, MLT, LUCY
A0, A1, A1B	-	OT20, R01030	FLOXI2R*	ERA INTI, ERA ONE, ERA FLOR, NICEWAY FLOR-S, FLOR-M, ONE, VERY VR		EL, ML, MLT, LUCY
A3, A3F A6, A6F A700F	A3BA + A3G0 A3FBA + A3G0 SPSB059DE SPSB059DEF SPSB059DF	T04005, T04006, T04015, T04605, T05015, T05016, T05605 HY7100, HY7005, WG4000, WG5000, MFAB3000, MFAB3000L, LFAB4000, T003000, T004500	FLOXI2R*	ERA INTI, ERA ONE, ERA FLOR, NICEWAY FLOR-S, FLOR-M, ONE, VERY VR		EL, ML, MLT, LUCY
A400	102-A.8001	WG4000	OXI SMXI*	ERA INTI, ERA ONE, ERA FLOR, NICEWAY FLOR-S, FLOR-M, FLO, ONE, SMILO, VERY VR, VERY VE		EL, ML, MLT, LUCY
A100F Universal control unit for 230 Volt single motor	129-A.8001	OT20, R01030	SMXI*	ERA INTI, ERA ONE, ERA FLOR, NICEWAY FLOR-S, FLOR-M, FLO, ONE, SMILO, VERY VR, VERY VE		EL, ML, MLT, LUCY
A60	SPSB138D	T04005, T04006, T04015, T04605, T05015, T05016, T05605 HY7100, HY7005, WG4000, WG5000, MFAB3000, MFAB3000L, LFAB4000, T003000, T004500	FLOXI2R*	ERA INTI, ERA ONE, ERA FLOR, NICEWAY FLOR-S, FLOR-M, FLO, ONE, VERY VR, VERY VE		EL24 ML24, ML24T LUCY24
A500	096-B.8001	Universal control unit for single motor (Power supply 230 V - 400 V)	FLOXI2R*	ERA INTI, ERA ONE, ERA FLOR, NICEWAY FLOR-S, FLOR-M, FLO, ONE, VERY VR, VERY VE	EL24 ML24, ML24T LUCY24	
A824	SP081-B	MB4024, MB5024, HY7024, HY7124, MFAB3024	FLOXI2R*	ERA INTI, ERA ONE, ERA FLOR, NICEWAY FLOR-S, FLOR-M, FLO, ONE, VERY VR, VERY VE	EL24 ML24, ML24T LUCY24	
A824T		T04024, T05024, T07024				
A924	SB105B	SU2000, SU2000V, SU2000VV, SU2010				

# ALPHABETICAL INDEX

CODE	PRODUCT LINE	PAGE	CODE	PRODUCT LINE	PAGE
A01	Control unit for rolling doors without automatic closing	214	CHS	Neutral key for EKS, EKSI	194
A02	Control unit for rolling doors with automatic/ semiautomatic closing	214	CM-B	Mechanical sensitive edges, length 1.5 m	99
A500	Control unit for a three-phase or single-phase motor	214	CMA 1,5MT	Mechanical sensitive edges, length 1.7 m	205
A60	Control unit for two motors with electric clutch	215	CMA 1,7MT	Mechanical sensitive edges, length 2 m	205
A6F	Control unit for two motors 230 Vac, with electric clutch, pull-out terminal boards	215	CMA 2MT	Mechanical sensitive edges, length 2.5 m	205
A700F	Control unit for two motors with electric clutch, possibility of adding PIU	215	CMA 2,5MT	Pawl with two metal release keys	205
A924	Control unit for one motor with encoder	215	CMBK4	Kit for installing a low mechanical edge, with aluminium profiles measuring 4 m (to use together with CB)	205
ABF	Tuned directional aerial, for mounting on bracket	170	CMBK6	Kit for installing a low mechanical edge, with aluminium profiles measuring 6 m (to use together with CB)	205
ALA1	Battery charger power supply unit	176	CRA1	Mechanical accessory, shaft with 18-tooth pinion	145
B12-B	12 V, 6 Ah batteries	35	CRA2	Mechanical accessory, joint for chain	145
B12V-C	12 V, 2 Ah battery	215	CRA3	Mechanical accessory, 1/2" chain, 1 m pack, plus joint for chain	145
BA3-A	Nice battery box	145	CRA4	Mechanical accessory, 1/2" chain, 5 m pack, plus joint for chain	145
BFAB5024	Big-Fab, Motor for swing gates, underground installation, with leaves up to 5 m, with mechanical limit switch on closing	82	CRA5	Mechanical accessory, tensioner drive with brackets	145
BFABBOX	Fab accessory, Foundation box with cathoporesis paint finish	82	CRA6	Mechanical accessory, 36-tooth pinion	145
BFABBOXI	Fab accessory, Stainless steel foundation box	82	CRA7	Mechanical accessory, 18-tooth pinion	145
BM1000	Additional memory card (255 codes memory)	195	CRA8	Mechanical accessory, wall-fixing bracket	145
BMA1	L-Fab and Big-Fab accessory, Accessory for opening up to 360°	81	CRA9	Mechanical accessory, adapter for shafts	143
BMA2	L-Fab and Big-Fab accessory, Adapters for the installation of two motors	80	DBM10	Complete kit for electrical connection of sensitive edges, for gates up to 10 m	204
CABLA01	Cable for connecting O-Box to the computer	176	DBM5	Complete kit for electrical connection of sensitive edges, for gates up to 5 m	204
CABLA02	Optical reader for programming transmitters Bio and FloR	176	DBM7,5	Complete kit for electrical connection of sensitive edges, for gates up to 7.5 m	204
CABLA03	Cable for cloning transmitters in the series Very	176	EDS	Era Keypad, digital selector 12 keys to be combined with the MORX decoder	192
CABLA04	Cable for cloning transmitters in the series FloR	176	EDSB	Era Keypad, 12 key digital selectors with nice blueBUS technology, burglar-resistant metal body	192
CABLA05	Cable for programming tubular motors, equipped with port TTBUS	176	EDSI	Era Keypad, 12 key digital selectors with nice blueBUS technology, for recessed mounting burglar-resistant metal body	192
CABLA06	Cable for programming receivers universal in the series SMX and OX	176	EDSIB	Era Keypad, digital selector 12 keys, for recessed mounting, to be combined with the MORX decoder	192
CABLA07	Cable for cloning transmitters in the series Ergo and Plano	176	EDSWG6	Era Keypad wireless, 13 key digital selector, with radio connection	193
CABLA09	Cable for cloning transmitters in the series Era-Flor	176	EKA01	Era Post, plug for mounting of EKS, EKSEU, EDS, EDSB, EDSW, ETP, ETPB, on PPH2 post	196
CARICA	Plug-in card for battery charger	215	EKA02	Finishing kit for EDSI, EDSIB, EKSI, EKSI EU installation	192
CB	Mechanical sensitive edges - protective rubber pad	205	EKA03	Bowl for recessed mounting (depth 66 mm) for installation of EKSI, EKSI EU. also compatible with EPLIO, EPLIOB, EDSI, EDSIB	191
CHEU	Neutral key for EKSEU, EKSI EU	194	EKS	Era Key Switch, key selector for outdoor installation	194

CODE	PRODUCT LINE	PAGE
EKSEU	Era Key Switch, key selector, european cylinder, for outdoor installation	194
EKSI	Era Key Switch, key selector for recessed mounting	194
EKSIEU	Era Key Switch, key selector, european cylinder, for recessed mounting	194
EL	Era Light, Neutral flashing signal light, 230 Vac, for preset control units	198
EL24	Era Light, Neutral flashing signal light, 24 Vac/Vdc, for preset control units	198
ELB	Era Light, Neutral flashing signal light, 12 Vac/Vdc, for preset control units	198
EPL	Era Photocell L, pair of surface-mounted photocells large	191
EPLB	Era Photocell L, pair of surface-mounted photocells large, 30° positionable	191
EPLIO	Era Photocell L, pair of surface-mounted photocells large, 30° positionable, with Nice BlueBUS technology	191
EPLIOB	Era Photocell L, pair of surface-mounted photocells large, with Nice BlueBUS technology	191
EPLD	Era Photocell L, pair of photocells large for recessed mounting, 30° positionable	191
EPLDB	Era Photocell L, pair of photocells large for recessed mounting, 30° positionable, with Nice BlueBUS technology	191
EPM	Era Photocell M, pair of outdoor photocells	189
EPMA	Era Photocell M, pair of outdoor photocells, 30° positionable	189
EPMAB	Era Photocell M, pair of outdoor photocells, 30° positionable, with Nice BlueBUS technology	189
EPMAO	Era Photocell M, pair of outdoor photocells, burglar-resistant metal body	189
EPMAOB	Era Photocell M, pair of outdoor photocells, 30° positionable, burglar-resistant metal body	189
EPMB	Era Photocell M, pair of outdoor photocells, 30° positionable, burglar-resistant metal body, with Nice BlueBUS technology	189
EPMO	Era Photocell M, pair of outdoor photocells, burglar-resistant metal body, with Nice BlueBUS technology	189
EPMOB	Era Photocell M, pair of outdoor photocells, with Nice BlueBUS technology	189
EPS	Era Photocell S, pair of outdoor photocells slim	187
EPSA	Era Photocell S, pair of outdoor photocells slim, burglar-resistant metal body	187
EPSAB	Era Photocell S, pair of outdoor photocells slim, with Nice BlueBUS technology, burglar-resistant metal body	187
EPSB	Era Photocell S, pair of outdoor photocells slim, with Nice BlueBUS technology	187
ERA P VIEW	Multifunction radio transmitter with intuitive graphic interface, to manage up to 99 devices singly or in groups	159
ETP	Era Transponder Reader, proximity reader for transponder cards MOCARD and MOCARDP to be combined with the MORX decoder	195
ETPB	Era Transponder Reader, proximity reader for transponder cards with Nice BlueBUS technology	195
F210	Pair of synchronised photocells, with relay output	207
F210B	Pair of synchronised photocells, with the Nice BlueBUS technology	207

CODE	PRODUCT LINE	PAGE
FA1	Vandal-proof metal shell for optical devices	206
FA2	Bracket for fixing vandal-proof metal shell to MOCF and MOCF2 columns	206
FLO1RCE	Era FloR transmitter, 1 channel, with sequential code for multiple insertion	165
FLO1RE	Era FloR transmitter, 1 channel	165
FLO2RCE	Era FloR transmitter, 2 channels, with sequential code for multiple insertion	165
FLO2RE	Era FloR transmitter, 2 channels	165
FLO4RCE	Era FloR transmitter, 4 channels, with sequential code for multiple insertion	165
FLO4RE	Era FloR transmitter, 4 channels	165
FLOX2R	Universal receiver, 2 channels with BM250 memory	161
FT210	Pair of optical devices for sensitive edges, with relay output	206
FT210B	Pair of optical devices for sensitive edges, with BlueBUS technology	206
FTA1	7 Ah battery kit for FT210/FT210B transmitters, for intensive use	206
FTA2	2 Ah battery kit for FT210/FT210B transmitters	206
GR170	Giro, Irreversible gear motor, with brake and release device, lifting force up to 170 kg	150
GR170E01	Giro, Irreversible gear motor, with brake and release device, lifting force up to 170 kg, power supply cable included	150
GR170R	Giro, Reversible gear motor, without brake, lifting force up to 170 kg	150
GR170RE01	Giro, Reversible gear motor, without brake, lifting force up to 170 kg, power supply cable included	150
GR340E01	Giro, Irreversible gear motor, bi-motor with brake and release device, lifting force up to 340 kg, power supply cable included	150
GRA01	Giro accessory, second motor for GR170 complete with accessories for simultaneous release	151
GRA02	Giro accessory, adapter for 48 mm diameter shafts	151
GRA03	Giro accessory, adapter for 240 mm diameter pinion	151
HK7024	Hyke, Motor for swing gates up to 3.5 m, with articulated arm and control unit	66
HK7024HS	Hyke HS, Hi-Speed motor for swing gates up to 3 m, with magnetic encoder, complete with articulated arm and control unit	28
HK7224	Hyke, Motor for swing gates up to 3.5 m, with articulated arm	66
HK7224HS	Hyke HS, Hi-Speed motor for swing gates up to 3 m, with articulated arm, without built-in control unit	28
HKA1	Hyke, Spare control unit for HK7024	67
HKA2	Hyke HS accessory, Spare control unit for HK7024HS	29
H07124	Hopp, Motor for swing gates up to 2.4 m, with articulated arm and control unit	62
H07224	Hopp, Motor for swing gates up to 2.4 m, with articulated arm, without control unit	62

# ALPHABETICAL INDEX

CODE	PRODUCT LINE	PAGE	CODE	PRODUCT LINE	PAGE
HOPPKCE	Hopp, Kit for swing gates with leaves up to 2.4 m, externally mounted	64	KIO	Key-operated selector switch for low voltage contacts with release mechanism for metal cord	208
HSB1	Trasponder badge for proximity reader	161	KIOMINI	Aluminium key switch with control and release mechanism	208
HSTS2IT	Touch screen wireless for managing Nice home automation	161	LBAR	Road barrier system for bars from 7 to 9 m, steel case with protective cataphoresis treatment	116
HSTSA1	Base di ricarica per touch screen completa di batterie ricaricabili	161	LBARI	Road barrier system for bars from 7 to 9 m, stainless steel case	116
HY7005	Hyppo, Motor for swing gates up to 3 m, articulated shear-proof arm, with limit switch on opening and closing	70	LFAB4000	L-Fab, Motor for swing gates, underground installation, with leaves up to 4 m, with mechanical limit switch on closing	80
HY7024	Hyppo, Motor for swing gates up to 3 m, with magnetic encoder, with shear-proof articulated arm	70	LFAB4024	L-Fab, Motor for swing gates, underground installation, with leaves up to 4 m, with encoder and mechanical limit switch on closing	80
HY7100	Hyppo, Motor for folding 2-leaf doors, 230 Vac, with telescopic arm and limit switch on opening and closing	146	LFABBOX4	L-Fab accessory, Foundation box with cataphoresis paint finish	80
HY7124	Hyppo, Motor for folding 2-leaf doors, with telescopic arm and limit switch on opening and closing, with magnetic encoder	146	LFABBOX4I	L-Fab accessory, Stainless steel foundation box	80
HYA11	Hyppo, Unlock from inside with a 6 m cord	147	LLW	Wireless flashing light with built-in photovoltaic panel	202
HYA12	Hyppo, Longer articulated arm	71	LP1	Single-channel metal mass detector 24 V power supply	205
HYKEKCE	Hyke, Kit for swing gates with leaves up to 3.5 m, with articulated arm, externally mounted	68	LP2	Two-channel metal mass detector 24 V power supply	205
IB	Interface for connecting BlueBUS photocells up to control units which have not been manufactured for this purpose	187	M3BAR	Road barrier system for bars of 3 m, steel case with protective cataphoresis treatment	112
IBW	Interface between PHW/LLW and control units with BLUEBUS system	202	M3BARI	Road barrier system for bars of 3 m, stainless steel case	112
INB	Communication interface between Bticino Bus (SCS) and Nice Bus (TTBus and BusT4)	175	M5BAR	Road barrier system for bars of 4 or 5 m, steel case with protective cataphoresis treatment	112
INTI1	Era Inti transmitters, 1 channel, 433,92 MHz, black	162	M5BARI	Road barrier system for bars of 4 or 5 m, stainless steel case	112
INTI1B	Era Inti transmitters, 1 channel, 433,92 MHz, blue	162	M7BAR	Road barrier system for bars of 5, 6 or 7 m, steel case with protective cataphoresis treatment	112
INTI1G	Era Inti transmitters, 1 channel, 433,92 MHz, green	162	M7BARI	Road barrier system for bars of 5, 6 or 7 m, stainless steel case	112
INTI1L	Era Inti transmitters, 1 channel, 433,92 MHz, lilac	162	MC424L	Control unit for swing gates with one or two 24 Vdc motors, with Solemyo technology	213
INTI1R	Era Inti transmitters, 1 channel, 433,92 MHz, red	162	MC824H	Control unit for one or two motors at 24 Vdc, with BlueBUS technology, compatible for Opera and Solemyo systems	212
INTI1Y	Era Inti transmitters, 1 channel, 433,92 MHz, yellow	162	MCA1	Spare control unit for MC824H	212
INTI2	Era Inti transmitters, 2 channels, 433,92 MHz, black	162	MCA2	Spare control unit for MC424L	213
INTI2B	Era Inti transmitters, 2 channels, 433,92 MHz, blue	162	MEA1	Mechanical accessory for opening up to 360° for gates max. 2.5 m in length	31
INTI2G	Era Inti transmitters, 2 channels, 433,92 MHz, green	162	MEA2	Fab accessory, Key unlock system	31
INTI2L	Era Inti transmitters, 2 channels, 433,92 MHz, lilac	162	MEA3	Fab accessory, Lever-type key unlock system	31
INTI2R	Era Inti transmitters, 2 channels, 433,92 MHz, red	162	MEA5	Fab accessory, Lever-type unlock key for MEA3	31
INTI2Y	Era Inti transmitters, 2 channels, 433,92 MHz, yellow	162	MEA6	Fab accessory, Limit switch bracket	31
INTIKIT	Era Inti, Kit composed by three 2-channel transmitters Era Inti (red, green, blue) and one receiver OX2	162	MFAB3000	M-Fab, Motor for swing gates with leaves up to 3 m, underground installation, grease lubrication, increased speed	78
IRW	Wireless relay interface for sensitive edges	203	MFAB3000L	M-Fab, Motor for swing gates with leaves up to 3 m, underground installation, grease lubrication, cruising speed	78
KA1	6 m cable release kit for KIO	208	MFAB3024	M-Fab, Motor for swing gates with leaves up to 3 m	78



CODE	PRODUCT LINE	PAGE
<b>MFAB3024HS</b>	M-Fab HS, Hi-Speed motor for swing gates with leaves up to 3 m, with magnetic encoder	<b>30</b>
<b>MFABBOX</b>	Fab accessory, Externally chamfered foundation box with cathoporesis finish with mechanical stop on opening	<b>30</b>
<b>MFABBOXI</b>	Fab accessory, Externally chamfered foundation box in stainless steel with mechanical stop on opening	<b>30</b>
<b>MOCARD</b>	Transponder card programmable via OBOX	<b>195</b>
<b>MOCARDP</b>	Transponder card programmable via OBOX, with sequential coding	<b>195</b>
<b>MOCF</b>	Aluminium post for 1 photocell, 500 mm high	<b>206</b>
<b>MOCF2</b>	Aluminium post for 2 photocells, 1000 mm high	<b>206</b>
<b>MORX</b>	Decoder for 1 ETP or up to 4 EDS/EDSI connected in parallel with memory BM1000	<b>192</b>
<b>NKA3</b>	Spare control unit	<b>89</b>
<b>NKSL400</b>	Naked, Concealed motor for swing gates up to 400 kg, with control unit and absolute encoder	<b>89</b>
<b>NSEA</b>	Instrument for force impact measurement, angular extension	<b>204</b>
<b>NSEL</b>	Instrument for force impact measurement, straight extension	<b>204</b>
<b>NSFB</b>	BlueForce SMART instrument for measuring the impact force compliant with EN12445, with Plug Bluetooth/USB and software included	<b>204</b>
<b>NSFS</b>	BlueForce SMART instrument for measuring the impact force compliant with EN12445, with USB interface and software included	<b>204</b>
<b>OBOX2</b>	Connection interface complete with software "O-Box Software Suite", with USB connection cable supplied	<b>176</b>
<b>OBOX2B</b>	Connection interface complete with software "O-Box Software Suite", with USB connection cable and integrated Bluetooth module	<b>176</b>
<b>ON1CE</b>	Era One transmitter, 1 channel, 433,92 MHz, with sequential code for multiple insertion	<b>164</b>
<b>ON1E</b>	Era One transmitter, 1 channel, 433,92 MHz	<b>164</b>
<b>ON1EFM</b>	Era One transmitter, 1 channel, 868,46 MHz	<b>164</b>
<b>ON2CE</b>	Era One transmitter, 2 channels, 433,92 MHz, with sequential code for multiple insertion	<b>164</b>
<b>ON2E</b>	Era One transmitter, 2 channels, 433,92 MHz	<b>164</b>
<b>ON2EFM</b>	Era One transmitter, 2 channels, 868,46 MHz	<b>164</b>
<b>ON4CE</b>	Era One transmitter, 4 channels, 433,92 MHz, with sequential code for multiple insertion	<b>164</b>
<b>ON4E</b>	Era One transmitter, 4 channels, 433,92 MHz	<b>164</b>
<b>ON4EFM</b>	Era One transmitter, 4 channels, 868,46 MHz	<b>164</b>
<b>ON9E</b>	Era One transmitter, 9 channels, 433,92 MHz	<b>164</b>
<b>ON9EFM</b>	Era One transmitter, 9 channels, 868,46 MHz	<b>164</b>
<b>OTA11</b>	Mechanical accessory, Kit for external unlocking with a metal cord	<b>139</b>
<b>OTA12</b>	Mechanical accessory, Kit for external unlocking with key ratchet	<b>139</b>

CODE	PRODUCT LINE	PAGE
<b>OTA2</b>	Mechanical accessory, Motor support bracket (1250 mm long)	<b>139</b>
<b>OTA3</b>	Mechanical accessory, Motor support bracket (2000 mm long)	<b>139</b>
<b>OTA9</b>	Mechanical accessory, Motor support bracket (520 mm long)	<b>139</b>
<b>OVA1</b>	O-View Accessory, Clamp for fitting connectors RJ14	<b>174</b>
<b>OVA2</b>	O-View Accessory, Connectors RJ14, type 6/4, for flat 4-wire cable	<b>174</b>
<b>OVA3</b>	O-View Accessory, RJ14 splitters, type 6/4, for cascade connection	<b>174</b>
<b>OVA4</b>	O-View Accessory, Flat 4-wire cable for connection of devices	<b>174</b>
<b>OVB1</b>	O-View, Bluetooth module for O-View and software for PC, PDA or Smartphone	<b>174</b>
<b>OVB1GSM</b>	O-View, GSM module and software for PC, PDA or Smartphone	<b>174</b>
<b>OVIEW</b>	Unit for control, programming and diagnostics of devices equipped with BUS T4 connection	<b>174</b>
<b>OX2</b>	Prewired receiver 433,92 MHz, 2 channels, without built-in transmitter	<b>170</b>
<b>OX2FM</b>	Prewired receiver 868,46 MHz, 2 channels, without built-in transmitter	<b>170</b>
<b>OX2T</b>	Prewired receiver 433,92 MHz, 2 channels, with built-in transmitter	<b>170</b>
<b>OX2TFM</b>	Prewired receiver 868,46 MHz, 2 channels, with built-in transmitter	<b>170</b>
<b>OX4T</b>	Universal receiver 433,92 MHz, 4 channels, with built-in transmitter	<b>170</b>
<b>OXI</b>	Receiver with connector, 433,92 MHz, 4 channels, without built-in transmitter	<b>170</b>
<b>OXIFM</b>	Receiver with connector, 868,46 MHz, 4 channels, without built-in transmitter	<b>170</b>
<b>OXIT</b>	Receiver with connector, 868,46 MHz, 4 channels, with built-in transmitter	<b>170</b>
<b>OXITFM</b>	Prewired receiver 868,46 MHz, 4 channels, with built-in transmitter	<b>170</b>
<b>PHW</b>	Pair of wireless photocells with built-in photovoltaic panel	<b>202</b>
<b>PHWA1</b>	Pair of adapters for PHW on PPH1 posts	<b>202</b>
<b>PIU</b>	Expansion card for additional functions of control unit	<b>214</b>
<b>PLA10</b>	Mechanical accessory, Vertical 12 V electric lock	<b>23</b>
<b>PLA11</b>	Mechanical accessory, Horizontal 12 V electric lock	<b>23</b>
<b>PLA13</b>	Mechanical accessory, Mechanical travel stops for closing and opening manoeuvres	<b>43</b>
<b>PLA14</b>	Mechanical accessory, Screw-adjustable rear bracket	<b>27</b>
<b>PLA15</b>	Mechanical accessory, Screw-adjustable front bracket	<b>27</b>
<b>PLA6</b>	Mechanical accessory, Rear bracket 250 mm long	<b>23</b>
<b>PLA8</b>	Mechanical accessory, Screw-adjustable front bracket	<b>23</b>

FOR SWING GATES

FOR SLIDING GATES

BARRIER GATE  
OPERATOR SYSTEMSFOR GARAGE  
AND INDUSTRIAL DOORSCONTROL SYSTEMS  
AND ACCESSORIESCOMPATIBILITY TABLE  
AND ALPHABETICAL INDEX

# ALPHABETICAL INDEX

CODE	PRODUCT LINE	PAGE	CODE	PRODUCT LINE	PAGE
POA3	Spare control unit for H07124	63	RN2020	Rondo, Reversible motor without brake for balanced rolling doors up to 180 kg	152
PPH1	Era Post, Outdoor aluminium post for 1 photocell medium and large, height 500 mm	196	RN2030	Rondo, Irreversible motor with brake and release device for balanced rolling doors up to 130 kg	152
PPH2	Era Post, Outdoor aluminium post for 2 photocells medium and large, height 1000 mm	196	RN2040	Rondo, Irreversible motor with brake and release device for balanced rolling doors up to 180 kg	152
PPH3	Era Post, Outdoor aluminium post for 1 photocell medium size, height 500 mm	196	RNA01	Rondo Accessory, Electronic brake for RN2020 and RN2010	153
PPH4	Era Post, Outdoor aluminium post for 2 photocells medium size, height 1000 mm	196	ROA6	M4 25x20x1000 mm slotted nylon rack with metal insert for gates weighing up to 500 kg	105
PPK	Era Post, Outdoor aluminium post for 1 selector, height 1100 mm	196	ROA7	M4 rack, zinc coated, 22x22x1000 mm	105
PS124	24 V battery with integrated battery charger	29	ROA8	M4 rack, 30x8x1000 mm, zinc coated with spacers and screws	105
PS224	24 Vdc buffer battery	114	ROA81	M6 rack, 30x30x1000 mm, zinc coated	105
PS324	24 V battery with integrated battery charger (for motor in 24Vdc version)	23	RUA1	Spare control unit for RUN1800/1800P and RUN2500/2500P	103
PS424	Buffer battery	59	RUA12	12-teeth pinion, module 6, to be coupled with rack ROA81	35
PS524	Charge card for 7 Ah batteries	35	RUA2	Run accessory, Spare control unit for RUN2500I	103
PSY24	24 V battery box with control circuit and carry handle	201	RUA3	Run accessory, Spare inverter for RUN2500I	103
PUL	Central cover with incorporated control buttons, complete with connecting cable and connector for A500	214	RUA6	Run accessory, Spare control unit for RUN400HS e RUN1200HS	35
PW1	Heating element for the automation system	209	RUN1200HS	Run HS, Hi-Speed motor for sliding gates up to 1500 kg, with control unit and electromechanical limit switch	34
RB1000	Robus, Motor for sliding gates up to 1000 kg with control unit and electromechanical limit switch	92	RUN1500	Run, Motor for sliding gates up to 1500 kg, with control unit and electromechanical limit switch	100
RB1000P	Robus, Motor for sliding gates up to 1000 kg with control unit and inductive limit switch	92	RUN1500P	Run, Motor for sliding gates up to 1500 kg, with control unit and inductive limit switch	100
RB250HS	Robus HS, Hi-Speed motor for sliding gates up to 250 kg with control unit and electromechanical limit switch	32	RUN1800	Run, Motor for sliding gates up to 1800 kg, with control unit and electromechanical limit switch	102
RB400	Robus, Motor for sliding gates up to 400 kg with control unit and electromechanical limit switch	92	RUN1800P	Run, Motor for sliding gates up to 1800 kg, with control unit and inductive limit switch	102
RB400KCE	Robus, Kit for sliding gates up to 400 kg with control unit and electromechanical limit switch	94	RUN2500	Run, Motor for sliding gates up to 2500 kg, with control unit and electromechanical limit switch	102
RB500HS	Robus HS, Hi-Speed motor for sliding gates up to 500 kg with control unit and electromechanical limit switch	32	RUN2500I	Run, Motor for sliding gates up to 2500 kg, with control unit, inverter and electromechanical limit switch	102
RB600	Robus, Motor for sliding gates up to 600 kg with control unit and electromechanical limit switch	92	RUN2500P	Run, Motor for sliding gates up to 2500 kg, with control unit and inductive limit switch	102
RB600KCE	Robus, Kit for sliding gates up to 600 kg with control unit and electromechanical limit switch	96	RUN400HS	Run HS, Hi-Speed motor for sliding gates up to 400 kg, with control unit and electromechanical limit switch	34
RB600P	Robus, Motor for sliding gates up to 600 kg with control unit and inductive limit switch	92	SBAR	Bar system for bars up to 4 m, with steel case with protective cathaphoresis treatment and paint finish	110
RBA1	Accessory for sliding gates, Inductive limit switch	33	SBARI	Bar system for bars up to 4 m, with stainless steel case	110
RBA3	Robus accessory, Spare control unit for RB400, RB600/600P, RB1000/1000P and RUN1500/1500P	93	SIA1	SBAR and WIDE accessory, Anchorage base with clamps	111
RBA3/HS	Robus accessory, Spare control unit for RB250HS and RB500HS	33	SIA2	WIDE accessory, Anchorage base with clamps	123
RBA4	Road accessory, Spare control unit for RDKCE	99	SLH400	Slight, Irreversible motor for sliding gates up to 400 kg with built-in control unit and absolute encoder	89
RDKCE	Road, Kit for sliding gates up to 400 kg and leaves up to 6 m, with control unit and receiver	98	SLH400KCE	Slight Kit, Kit for sliding gates up to 400 kg, with control unit and absolute encoder, built-in LED light	90
RN2010	Rondo, Reversible motor without brake for balanced rolling doors up to 130 kg	152	SMX2R	Universal pre-wired receiver, 2 channels, with memory containing 256 codes- Smilo coding	161

CODE	PRODUCT LINE	PAGE
SMXI	Universal pre-wired receiver, up to 4 channels, with memory containing 256 codes - Flo coding	170
SN6031	Spinbus, Motor for sectional doors and up-and-over garage doors, with built-in control unit, 800 N	130
SN6041	Spinbus, Motor for sectional doors and up-and-over garage doors, with built-in control unit, 1000 N	130
SNA1	Spinbus accessory, Spare control unit for SPIN10KCE and SPIN11KCE	137
SNA16	Spinbus accessory, Quick-connect brackets for ceiling mounting	129
SNA2	Spinbus accessory, Spare control unit for SPIN20KCE, SPIN21KCE and SPIN22KCE	133
SNA20	Spinbus accessory, Spare control unit for SPIN23KCE	135
SNA3	Spinbus accessory, Spare control unit for SPIN30/SN6031	129
SNA30	Spinbus accessory, Preassembled 3 m guide	130
SNA31	Spinbus accessory, 1 m extension for guide SNA30	130
SNA4	Spinbus accessory, Spare control unit for SPIN40/SN6041	129
S02000	Soon, Motor for sectional door up to 5 m, with absolute encoder	142
SOA2	Soon accessory, Spare control unit S02000	143
SPA2	Spinbus accessory, Kit for unlocking from the outside with cable	129
SPA5	Spinbus accessory, Oscillating arm sliding on bearings with optimised structure for projecting up-and-over doors	129
SPA6	Spinbus accessory, Large 585 mm long connecting arm	129
SPA7	Spinbus accessory, Kit of two additional fixing brackets	129
SPIN10KCE	Spinkit, For sectional doors up to 8.8 m <sup>2</sup> and up-and-over doors up to 9.8 m <sup>2</sup> . Guide in one 3-metre section	136
SPIN11KCE	Spinkit, For sectional doors up to 8.8 m <sup>2</sup> and up-and-over doors up to 9.8 m <sup>2</sup> . 3 m pre-assembled guide	136
SPIN20KCE	Spinbuskit, For sectional doors up to 10.5 m <sup>2</sup> and up-and-over doors up to 11.8 m <sup>2</sup> . Guide in one 3-metre section	132
SPIN21KCE	Spinbuskit, For sectional doors up to 10.5 m <sup>2</sup> and up-and-over doors up to 11.8 m <sup>2</sup> . 3 m pre-assembled guide	132
SPIN22KCE	Spinbuskit, For sectional doors up to 10.5 m <sup>2</sup> and up-and-over doors up to 11.8 m <sup>2</sup> . Guide in one 3-metre section + one 1-metre section	132
SPIN23KCE	Spinbuskit, For sectional doors up to 10.5 m <sup>2</sup> and up-and-over doors up to 11.8 m <sup>2</sup> . 3 m pre-assembled guide. Compatible with Solemyo and Opera	134
SPIN30	Spinbus, For sectional doors up to 12.5 m <sup>2</sup> and up-and-over doors up to 11.8 m <sup>2</sup> , 800 N	128
SPIN40	Spinbus, For sectional doors up to 12.5 m <sup>2</sup> and up-and-over doors up to 11.8 m <sup>2</sup> , 1000 N	128
SU2000	Sumo, For sectional doors and two-wings sliding doors up to 35 m <sup>2</sup>	144
SU2000V	Sumo, For sectional doors and two-wings sliding doors up to 25 m <sup>2</sup> , high speed	144
SU2000VV	Sumo, For sectional doors and two-wings sliding doors up to 15 m <sup>2</sup> , super high speed	144
SU2010	Sumo, For sectional doors and two-wings sliding doors up to 35 m <sup>2</sup> , IP54	144

CODE	PRODUCT LINE	PAGE
SYA1	Solemyo accessory, Power supply unit for charging the battery PSY24 from the supply mains	201
SYKCE	Solar power kit comprising SYP photovoltaic panel and PSY24 battery box with charging control circuit	201
SYP	Photovoltaic panel for 24 V supply with maximum power 15 W	201
SYP30	Photovoltaic panel for 24 V supply with maximum power 30 W	201
TCA65	Sensitive edges accessory, Aluminium profile L=200 cm	204
TCB65	Sensitive edge in 10 m rolls	204
TCBS60	Passive sensitive edge in 10 m rolls	205
TCE	Sensitive edge accessory, Control interface for sensitive edge	204
TCF	Sensitive edge accessory, Scissors for cutting safety sensitive edges	204
TCK	Sensitive edge accessory, Kit for 8 sensitive edges composition	204
TCW1	Sensor for sensitive edge with wireless technology and battery power supply	203
TCW2	Sensor for sensitive edge with wireless technology and PV power supply	203
TN2010L	Ten, Upgraded motor for projecting and non projecting up-and-over doors, with control unit, absolute encoder and BlueBUS	138
TN2020L	Ten, Upgraded motor for projecting and non projecting up-and-over doors, without control unit	138
TN2030L	Ten, Upgraded motor for projecting and non projecting up-and-over doors, with control unit and receiver, mechanical limit switch	138
TNA1	Ten accessory, Spare control unit for TN2030L and TNLKCE	139
TNA2	Ten accessory, Spare control unit for TN2010L	139
TNA38	Ten accessory, Driving device for transmission shafts	139
TNA4	Ten accessory, 20x20 mm drive shaft (1500 mm long)	139
TNA5	Ten accessory, Pair of standard straight telescopic arms	139
TNA6	Ten accessory, Pair of standard curved telescopic arms	139
TNA8	Ten accessory, 20x20 mm drive shaft (200 mm long)	139
TNA9	Ten accessory, Additional connection cable and supports for wall-mounting of PS324 battery	139
TNLKCE	Ten, Upgraded kit for projecting and non projecting up-and-over doors with control unit, receivers and mechanical limit switch	140
T04005	Toona, Motor for swing up to 3 m, with limit switch on opening, increased speed	42
T04006	Toona, Motor for swing up to 3 m, with limit switch on opening and closing, increased speed	42
T04015	Toona, Motor for swing up to 3 m, with limit switch on opening, cruising speed	42
T04024	Toona, Motor for swing up to 3 m, mechanical stop on opening	42
T04605	Toona, Motor for swing up to 3 m, limit switch on opening, increased speed	42

# ALPHABETICAL INDEX

CODE	PRODUCT LINE	PAGE	CODE	PRODUCT LINE	PAGE
<b>T05015</b>	Toona, Motor for swing up to 5 m, with limit switch on opening, cruising speed	44	<b>WCO</b>	Go, Mini cover for NiceWay, orange	169
<b>T05016</b>	Toona, Motor for swing up to 5 m, with limit switch on opening and closing, cruising speed	44	<b>WEO</b>	Stone, Table shockproof holder, orange	168
<b>T05024</b>	Toona, Motor for swing up to 5 m, mechanical stop on opening	44	<b>WEW</b>	Stone, Table shockproof holder, white	168
<b>T05024HS</b>	Toona 5 HS, Hi-Speed motor for swing up to 5 m, with magnetic encoder, mechanical stop on opening and closing	22	<b>WG3524HS</b>	Wingo HS, Hi-Speed motor for swing gates with leaves up to 3 m, with magnetic encoder, mechanical stop on opening and closing	26
<b>T05024I</b>	Toona, Motor for swing up to 5 m, mechanical stop on opening, for intensive use	44	<b>WIA10</b>	Wide accessory, Pivot joint	122
<b>T05605</b>	Toona, Reversible motor for swing up to 5 m, limit switch on opening, increased speed	44	<b>WIA11</b>	Wide accessory, Joint for bar for Wide M	123
<b>T06024HS</b>	Toona 6 HS, Hi-Speed motor for swing up to 6 m, with magnetic encoder, mechanical stop on opening and closing	24	<b>WIA20</b>	Wide accessory, Spare control unit	122
<b>T07024</b>	Toona, Motor for swing up to 7 m, mechanical stop on opening and closing	46	<b>WIDEL</b>	Wide, Electromechanical road barrier system for bars up to 7 m, with painted galvanised steel case	120
<b>TOONA4024KCE</b>	ToonaKit, Kit for swing gates with leaves up to 3 m, surface mounted	48	<b>WIDELI</b>	Wide, Electromechanical road barrier system for bars up to 7 m, with stainless steel case	120
<b>TS</b>	Signboard	23	<b>WIDEM</b>	Wide, Electromechanical road barrier system for bars up to 4 m, with painted galvanised steel case	120
<b>TT1L</b>	Control unit for installations for lighting/irrigation systems, with radio receiver, IP55 protection	181	<b>WIDEMI</b>	Wide, Electromechanical road barrier system for bars up to 4 m, with stainless steel case	120
<b>TT1N</b>	Control unit for a 230 Vac motor, with radio receiver, IP55 protection	181	<b>WIDES</b>	Wide, Electromechanical road barrier system for bars up to 4 m, with painted galvanised steel case	120
<b>TT2D</b>	Control unit for installations for 230 Vac lighting systems, with receiver and switching module	180	<b>WIDESI</b>	Wide, Electromechanical road barrier system for bars up to 4 m, with stainless steel case	120
<b>TT2L</b>	Control unit for installations for 230 Vac lighting systems, with receiver	180	<b>WING04024KCE</b>	Wingo, Kit for swing gates with leaves up to 2 m, 24 Vdc, surface mounted	52
<b>TT2N</b>	Miniaturized control unit for a 230 Vac motor, with radio receiver	180	<b>WING05024KCE</b>	Wingo, Kit for swing gates with leaves up to 3.5 m, 24 Vdc, surface mounted	56
<b>TTX4</b>	Recessed transmitter, 4 channels, with mains power	179	<b>WING05KCE</b>	Wingo, Kit for swing gates with leaves up to 3.5 m, 24 Vdc, surface mounted, with A60	54
<b>TTXB4</b>	Recessed transmitter, 4 channels, with long battery life power	179	<b>WING0KCE/A60</b>	Wingo, Kit for swing gates with leaves up to 2 m, with A60	50
<b>TUB3500</b>	Tub, Motor for sliding gates up to 3500 kg, with built-in Mindy A500 control unit	104	<b>WLA1</b>	Walky accessory, Spare control unit for WL1024C	59
<b>TW1</b>	Regulation thermostat for PW1	209	<b>WLT</b>	Wallyght, Multi-function Led indicator	199
<b>WA10</b>	Bars accessory, Red adhesive reflector strips	111	<b>WM001C</b>	Niceway, Single channel module to control 1 automation system	167
<b>WA11</b>	Bars accessory, Adjustable stand for bars	111	<b>WM001G</b>	Niceway, Module to control 1 Open-Stop-Close automation system	167
<b>WA12</b>	Bars accessory, Mobile stand for bars	115	<b>WM002G</b>	Niceway, Module to control 2 Open-Stop-Close automation systems	167
<b>WA13</b>	Bars accessory, Aluminium rack (2 m) for WA1, WA21, WA22	115	<b>WM003C</b>	Niceway, Three channel module to control 3 automation systems	167
<b>WALKY1024KCE</b>	Walky, Kit for swing gates with leaf up to 1.8 m	58	<b>WM003C1G</b>	Niceway, Module to control 3 Step-by-Step and 1 Open-Stop-Close automation systems	167
<b>WALKY2024KCE</b>	Walky, Kit for swing gates with leaf up to 1.8 m, with EPMB e EKS	60	<b>WM003G</b>	Niceway, Module to control 3 Open-Stop-Close automation systems	167
<b>WAX</b>	Ondo, Table holder for Nice Way, white plastic + Ice Blue rubber	168	<b>WM004G</b>	Niceway, Module to control 4 Open-Stop-Close automation systems and sun sensor activation command	167
<b>WCF</b>	Go, Mini cover for NiceWay, fern green	169	<b>WM006G</b>	Niceway, Module to control 6 Open-Stop-Close automation systems	167
<b>WCG</b>	Go, Mini cover for NiceWay, graphite	169	<b>WM009C</b>	Niceway, Nine channel module to control 9 Step-by-Step automation systems	167
<b>WCI</b>	Go, Mini cover for NiceWay, Ice Blue	169	<b>WM080G</b>	Niceway, Module to control 80 Open-Stop-Close automation systems and sun sensor activation command	167

CODE	PRODUCT LINE	PAGE
WM240C	Niceway, Module to control 240 Step-by-Step automation systems	167
WRA	Opla, Rectangular wall plate, aluminium	169
WRB	Opla, Rectangular wall plate, black	169
WRG	Opla, Rectangular wall plate, graphite	169
WRS	Opla, Rectangular wall plate, seawater	169
WRT	Opla, Rectangular wall plate, neutral transparent	169
WRW	Opla, Rectangular wall plate, white	169
WSA	Opla, Squared wall plate, aluminium	169
WSB	Opla, Squared wall plate, black	169
WSG	Opla, Squared wall plate, graphite	169
WSS	Opla, Squared wall plate, seawater	169
WST	Opla, Squared wall plate, neutral transparent	169
WSW	Opla, Squared wall plate, white	169
WWW	Ondo, Magnetic wall support for Ondo	168
XBA10	Bars accessory, Pivoting connection for bars up to 4 m	114
XBA11	Joint for bars XBA15 and XBA14 (from 1950 mm to 2400 mm)	114
XBA13	Bars accessory, Rubber impact protection strip	111
XBA14	Bars accessory, White paint-finished aluminium bar 69x92x4150 mm	115
XBA15	Bars accessory, White paint-finished aluminium bar 69x92x3150 mm	114
XBA16	Bars accessory, Anchorage base with clamps	114
XBA17	Bars accessory, Anchorage base with clamps	117
XBA18	Bars accessory, Indicator lights for click fixture on upper or lower side of bar. Length 8 m	115
XBA19	Bars accessory, White paint-finished aluminium bar 45x58x4000 mm	111
XBA20	Spare control unit for SBAR	111
XBA3HF	Spare control unit	114
XBA4	Bars accessory, Indicator lights for click fixture on upper or lower side of bar	111
XBA5	Bars accessory, White paint-finished aluminium bar 69x92x5150 mm	115
XBA6	Bars accessory, Indicator lights for click fixture on upper or lower side of bar. Length 6 m	115
XBA7	Bars accessory, Integrable flashing light	111

CODE	PRODUCT LINE	PAGE
XBA8	Bars accessory, Integrable traffic light	114
XBA9	Bars accessory, Expansion joint	115
XFAB2024	X-Fab, Motor for swing gates with leaves up to 2.3 m, underground installation	72
XFAB2024KCE	X-Fab, Kit for swing gates with leaves up to 2.3 m, underground installation	74
XFAB2124	X-Fab, Motor for swing gates with leaves up to 2.3 m with encoder, underground installation	72
XFAB2124KCE	X-Fab, Kit for swing gates with leaves up to 2.3 m, underground installation, BlueBUS, compatible with Opera	76
XFABBOX	Fab accessory, Externally foundation box, with cataphoresis paint finish	72

FOR SWING GATES

FOR SLIDING GATES

BARRIER GATE  
OPERATOR SYSTEMSFOR GARAGE  
AND INDUSTRIAL DOORSCONTROL SYSTEMS  
AND ACCESSORIESCOMPATIBILITY TABLE  
AND ALPHABETICAL INDEX





# IMPROVING THE QUALITY OF LIFE BY SIMPLIFYING EVERYDAY MOVEMENTS

## GATE&DOOR

Systems for the automation of gates, garage doors and barriers.

## SCREEN

Systems for the automation of blinds, awnings and sun screens. The easiest way to get the right light.

## INDUSTRIAL DOOR

Systems for the automation of industrial applications: sectional and rolling doors, high speed doors and dock levellers.

## HOME SYSTEM

Integrated management of home alarm and automation systems.

## LIGHTING

A full range of devices for total lighting control.

**Nice**

Nice SpA  
Oderzo TV Italia  
Ph. +39.0422.85.38.38  
info@niceforyou.com

Find out more about Nice products and services on the website:  
[www.niceforyou.com](http://www.niceforyou.com)



NiceLoveEarth

Nice cares for the environment. Using natural paper it avoids excessive use of raw materials and forest exploitation. Waste is reduced, energy is saved and climate quality is improved.