

# NICE GATE&DOOR

SYSTEMS FOR THE AUTOMATION AND CONTROL OF GATES,  
GARAGE DOORS AND BARRIERS / CATALOGUE 2013





# NICE GATE&DOOR CATALOGUE 2013

4	DESIGNING A NICE WORLD
25	SYSTEMS FOR SWING GATES
73	SYSTEMS FOR SLIDING GATES
93	BARRIER GATE OPERATOR SYSTEMS
115	SYSTEMS FOR GARAGE AND INDUSTRIAL DOORS
141	CONTROL SYSTEMS
169	ACCESSORIES
191	CONTROL UNITS
204	PRODUCT CODE ALPHABETICAL INDEX

FOR VENETIAN BLINDS

FOR BLINDS  
AND SHUTTERS

FOR ALARM SYSTEMS

FOR GARAGE DOORS

FOR LIGHTING  
SYSTEMS

FOR GATES



# ALL IN ONE. IT'S NICE.

**A simple gesture is all you need to make the whole house move.**

**With Nice you can control and manage home automations for gates, garage doors, barriers, awnings and rolling shutters, alarm and lighting systems, and electrical loads; individual, in groups or scenarios.**

Wireless and solar systems make installation of any automation simple and cost effective, both in new constructions and restorations.

Nice is the simplest integration, the finest design, the best control electronics, to provide you the most comprehensive automation system!

Request the catalogues for the automation and management of sun protection **Nice Screen**, for alarm systems **NiceHome System** and **FontanaArte** for Indoor and Outdoor lighting systems.





FOR ROAD BARRIER SYSTEMS  
AND PARKING SYSTEMS

FOR INDUSTRIAL DOORS

# ONE NICE SYSTEM. OR RATHER, MANY.

**Nice offers a wide range systems for the automation of gates and doors for industrial applications and communities.**

## **NiceBar System**

Systems to control accesses in public and private parking areas, even where traffic is heavy. Performance, reliability and durability.

## **Nice Industrial\***

Automation systems for industrial applications: sectional and rolling doors, high speed doors and dock levellers.

## **NicePark System\*\***

Automatic management systems for off-street car-parks. Versatile, flexible and complete. Born fully grown!

\* Request the catalog for **Nice Industrial**.

\* Request the catalog for **NicePark System**.







# FOR GATES AND DOORS? FOR YOU.

**Ease of use, aesthetic quality, safety.**

**Nice is easy to offer because it's easy to install and use,  
thanks to a range of products which links innovation to design:**

1. technology for the installer
2. comfort for the user
3. simplicity for everyone

Satisfy the desire of comfort and peace of mind in the most exclusive and functional way, in a perfect Nice style. Always at your side with an accurate sales and after sales service, Nice recommends you to choose the automation system that best suits your needs.

**Nice, more support, closer to you!**





# YOUR HOME IN YOUR HAND!

**Nice introduces the new Era line of radio control systems:**  
a wider and colourful range of design transmitters, portable, miniaturized,  
wall mounted, multi-channel, ultra-thin, with timer, LCD display...

**The ideal solution for the management of multi-user systems  
with the maximum ease and simplicity!**





ERA ONE

ERA FLOR

ERA INTI



NICEWAY - STONE



ERA TOUCH



MOONTOUCH

MOONKEY



MYMOON



HSB1

## WITH JUST A CLICK

Small, slim and coloured, ideal to carry in your pocket and bag, or to use as stylish key rings; table-top or wall-mounted: the control of the entire home at your fingertips!

These are the Nice radio control systems, modular, rolling code or bimodal with built-in transponder: the choice is yours!

## TOUCH SCREEN

Integration of home alarm and automation systems. Era Touch is the wireless touch screen transmitter/programmer.

The easiest and comfortable solution to manage up to 99 systems, individual, in groups or scenarios.

## COMBINED, KEY OR TOUCH SELECTORS

Practical digital, lock type selectors or proximity systems, to enter and exit the home in total safety.



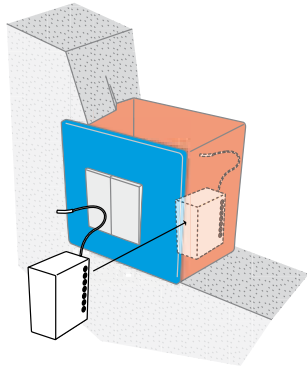

TAG SYSTEM



MOONBUS



ERA PHOTOCELL SOLEMYO



ERA LIGHT

## RECESSED SYSTEMS

Nice Tag, miniaturized transmitters and control units: disappearing inside the standard wall plates, they're ideal for restorations and upgrades of existing systems, to control home automations without the need to replace the existing system or performing masonry work.

## SAFER & SAFER

The comprehensive range of photocells equipped with BlueBUS and wireless technology; available in different sizes, they can be installed anywhere; perfect for renovations. Key and digital switches, flashing and courtesy lights. A versatile and practical range of accessories.

## AND MORE...

New web interfaces, scenarios and integrated systems... get ready for your new Nice lifestyle!





# HOW NICE!

**Improving the quality of life by simplifying everyday movements.  
The security of going in and out in total freedom, with the maximum comfort.  
This is the mission Nice wants to pursue: practical products with emotional design,  
in order to make the most of the housing space.**

With Nice, transmitters become objects to show: functional, miniaturized and elegant.  
Handy design: effortless and with only one hand.  
In its first generation of motors, Nice had already conceived release systems easy to operate with a simple key and only one hand.

*"For every job it is a question of attention, a lot of attention... in other words it's a question of love"*



2000  
"International  
Design Gallery"  
Expo 2000  
Hannover

**ADI**

2001  
Best of Category  
"Design for the  
Environment"  
XIX Compasso  
d'Oro



2002  
Permanent  
Collection  
at The Museum  
of Design



1999, 2003,  
2005  
"Intel Design  
Award"



1999, 2003,  
2005  
"ADI Design  
Index"



2005  
"Trophée  
d'Argent"  
Trophée  
du Design  
Batimat



2006  
"Innovation Prize"  
R+T Stuttgart



2007  
"Innovation &  
Design Award"  
LivinLuce



2008  
"Grandesign Etico  
International Award"





# NICE WIRELESS! SAFETY AND EASY AUTOMATION EVERYWHERE

**Nice Solemyo Air Net System: simpler, quicker, more flexible and safer automations.**

Greater savings and environment-friendly thanks to clean and free solar power:  
the intelligent, ecological choice.

Powered by the sun by means of built-in photovoltaic cells, the Nice gate automation system now goes wireless thanks to the new Nice Solemyo Air Net System product line: from the solar-powered automation kit to the sensitive edges, photocells, courtesy and flashing light.

## **BENEFITS FOR THE INSTALLER**

*Less wiring, no need to connect to the electrical mains.  
Quicker installation!*

*Flexible device positioning:  
easy addition or removal over time.  
Easier installation!*

## **BENEFITS FOR THE USER**

*More attractive.  
You put everything where you want it!*

*Lower wiring and installation costs*

*Low power consumption and no blackout risk with rechargeable batteries*





**Solemyo Kit (SYKCE):**  
the solar power kit for the automation  
of gates, garage doors and road barrier systems.  
Installable anywhere with no connections or excavations,  
even in the most remote places or difficult to access  
with mains electricity.

## SOLEMYO AIR NET SYSTEM

**WITH NICE IT IS NOW EASIER AND MORE EFFECTIVE TO CREATE  
A TRULY "TAILOR-MADE" SYSTEM, MEETING SPECIFIC SECURITY  
AND COMFORT REQUIREMENTS.**

**SIMPLICITY IS HERE!**



**Era Light Solemyo**  
Flashing signal light



**Era Photocell Solemyo**  
Photocell



**Era TCW Solemyo**  
Transmitter for sensitive edge

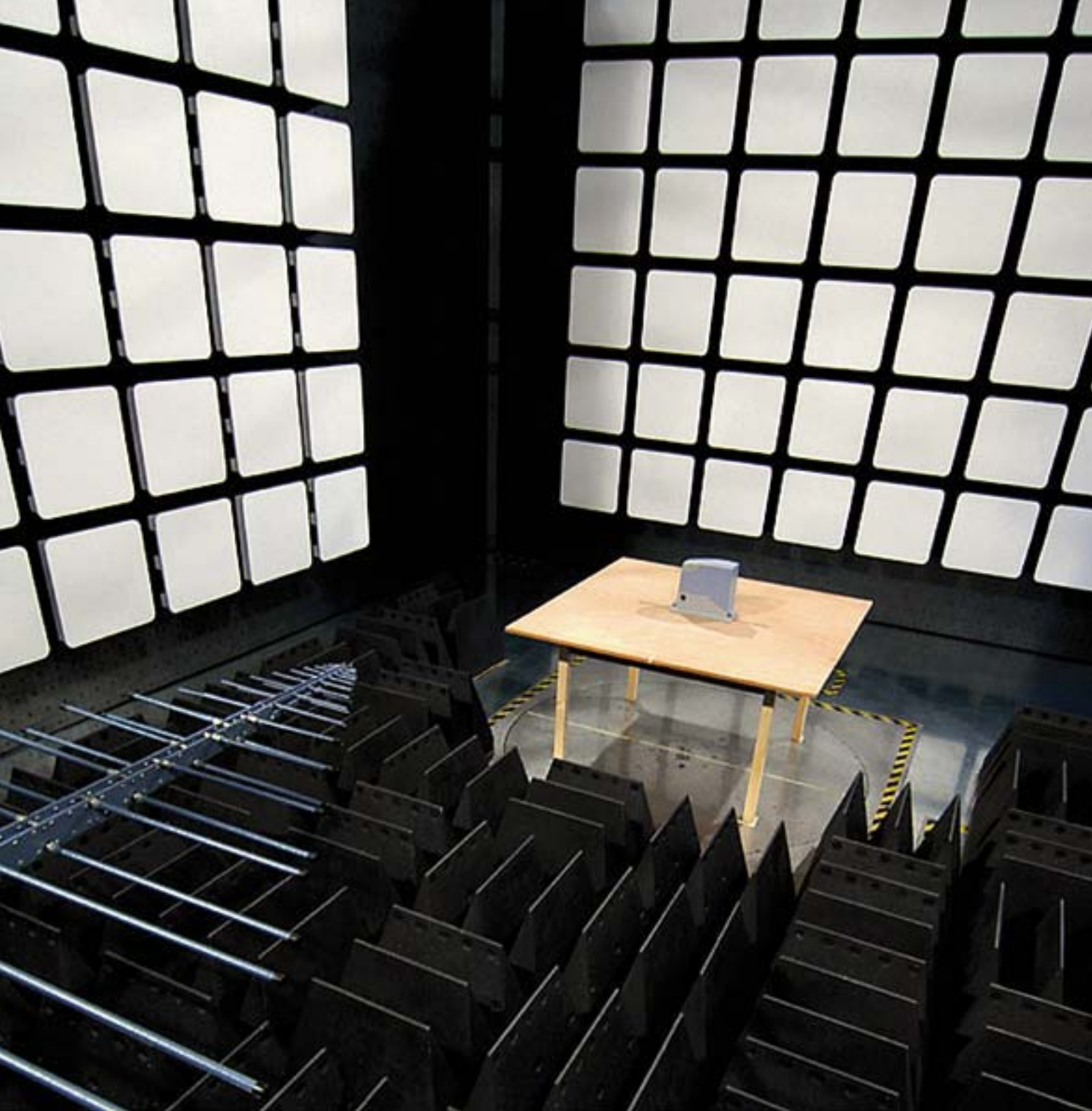

# NICE CENTRE FOR TECHNOLOGY

**Nice makes significant investments to guarantee even higher quality standards, which not only comply with directives and regulations, but also allow continuous product improvement.**

Through its advanced laboratories Nice carefully tests and controls its products every day in order to grant safety, quality, reliability and durability over time.

Nice has adopted a quality system that complies with standard **ISO 9001**, recognized worldwide for the quality management. The laboratory also meets the strict quality requirements of **EN 17025** standards.

Nice CE certified products comply with the European Directives and the leading internationally recognized standards.

Nice laboratories have been recognized by several international certification bodies:

- LCIE (France)
- Nemko (Norway)
- Cetecom (Germany)
- FCC (USA)
- IC (Canada)
- Intertek (Sweden)
- UL (USA)



Nice Headquarters,  
Oderzo, TV, Italy

# DESIGNING A NICE WORLD

## **A Nice Place.**

A new building, large and functional, to meet the needs of an ever-growing firm, reflecting its international focus and product personality: a training area and a showroom to interact with customers; an auditorium to foster institutional relationships with the world around.

At the core of its architecture, Nice has placed the person.

**[www.niceforyou.com](http://www.niceforyou.com)**

## **Nice + FontanaArte: light is movement.**

Thanks to the acquisition of FontanaArte, Nice enters the lighting system complementary sector.

Founded in 1932 by the architect Gio Ponti, FontanaArte is one of the Italian design firms which has “made history in lighting and furnishings” in Italy and around the world.

**[www.fontanaarte.com](http://www.fontanaarte.com)**

## **Nice Feel (for everyone everywhere liberty)**

It is the project created by Nice to promote and develop activities which give people with motor difficulties greater freedom in movement and more individual autonomy.



Suspension lamp  
**WIG**, Chris Hardy, 2011,  
courtesy of FontanaArte



**FEEL** (for everyone everywhere liberty)





# SYSTEMS FOR SWING GATES



SURFACE MOUNTED	30	TOONA 4
	32	TOONA 5
	34	TOONA 7
	36	TOONAKIT
	38	WINGOKIT
	40	WINGOKIT 4024
	42	WINGO5KIT
	44	WINGOKIT 5024

---

SURFACE MOUNTED, WITH ARTICULATED ARM	46	WALKYKIT 1024
	48	WALKYKIT 2024
	50	HOPP
	52	HOPPKIT
	54	HYKE
	56	HYKEKIT
	58	HYPPO 7000

---

UNDERGROUND INSTALLATION	60	X-FAB
	62	X-FABKIT 2024
	64	X-FABKIT 2124
	66	M-FAB
	68	L-FAB
	70	BIG-FAB

# SELECTION GUIDE

SURFACE MOUNTED, ALSO AVAILABLE IN KIT

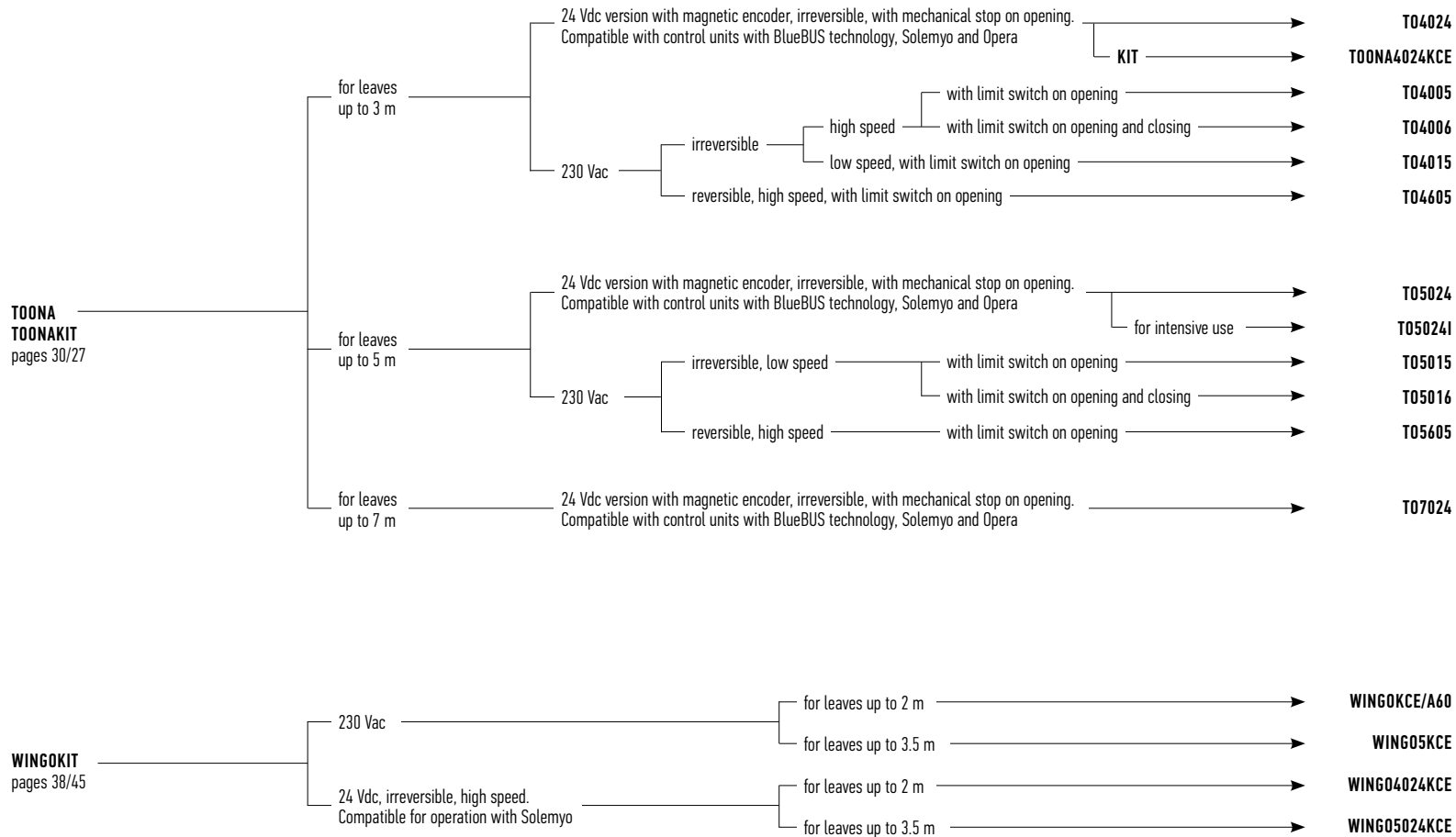

**SURFACE MOUNTED, WITH ARTICULATED ARM, RECOMMENDED FOR SMALL POSTS, IN KIT**

For leaves up to 1.8 m, 24 Vdc irreversible with built-in control unit equipped with BlueBUS technology, compatible for operation with Solemyo and Opera. Mechanical limit switch on closing.

**WALKYKIT**  
pages 46/49

for 1-leaf

for 2-leaf

**WALKY1024KCE**

**WALKY2024KCE**



**SURFACE MOUNTED, ARTICULATED ARM, ALSO FOR LARGE SIZE POSTS AND LIGHTWEIGHT STRUCTURES, ALSO AVAILABLE IN KIT**

For leaves up to 2.4 m, 24 Vdc, reversible. Control units compatible with Solemyo. With limit switch on opening.

**HOPP**  
**HOPPKIT**  
pages 50/53

integrated control unit, with BlueBUS technology, Solemyo and Opera

without control unit

**KIT**

**H07124**

**H07224**

**HOPPKCE**



# SELECTION GUIDE

## SURFACE MOUNTED, ARTICULATED ARM, FOR LARGE SIZE POSTS

For leaves up to 3.5 m, 24 Vdc irreversible with limit switches on opening and closing.

**HYKE**  
**HYKEKIT**  
pages 54/57

integrated control unit, with BlueBUS technology, Solemyo and Opera

without built-in control unit

**KIT**

**HK7024**

**HK7224**

**HYKEKCE**



For leaves up to 3 m, irreversible.

**HYPPO**  
pages 58/59

230 Vac with limit switch on opening and closing

24 Vdc version with magnetic encoder. Compatible with control units with BlueBUS technology, Solemyo and Opera

**HY7005**

**HY7024**



## UNDERGROUND INSTALLATION

For leaves up to 2.3 m, 24 Vdc irreversible, mechanical limit switches on opening and closing.

**X-FAB**  
**X-FABKIT**  
pages 60/65

compatible with control units for operation with Solemyo

with magnetic encoder, compatible with control units using BlueBUS technology, Solemyo and Opera

**KIT**

**KIT**

**XME2024**

**XMETRO2024KCE**

**XME2124**

**XMETRO2124KCE**



**UNDERGROUND INSTALLATION**

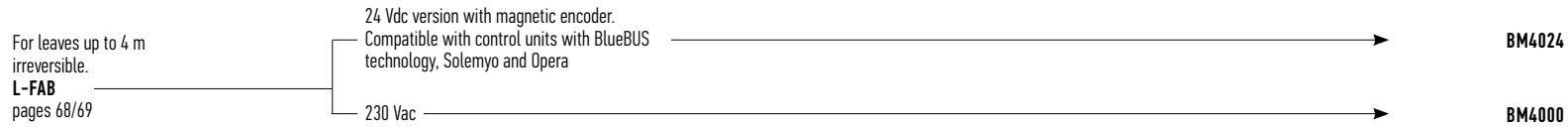
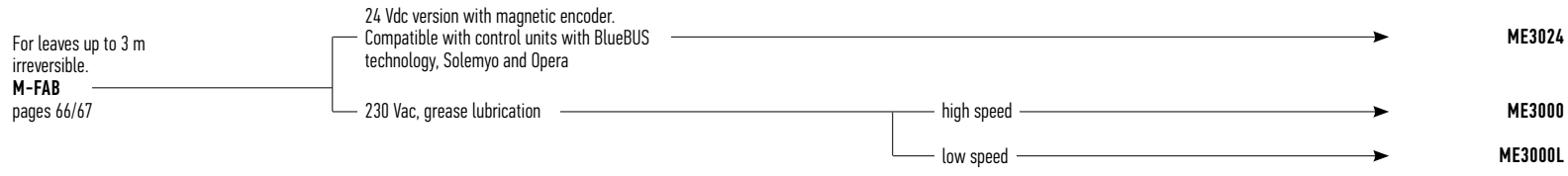

# TOONA 4

SOLEMYO OPERA BLUEBUS 24V 230V

## For swing gates with leaves up to 3 m.

Electromechanical gear motor, surface mounted.  
Also available in 24 Vdc version, with magnetic encoder.  
Ideal for residential use.

**Reliable:** durability thanks to the housing, made up of two tough aluminium shells with polyester paint finish; more resistant to atmospheric agents.

Internal moving parts completely in steel, light alloys and technopolymers.

**Silent:** patented layout of internal parts and lead nut in bronze.

**Generously sized and practical connection compartment:** rapid and easy access from above to internal parts located in the upper section of the motor.

**Simple installation and maintenance;** with built-in capacitor.

### Recommended control units:

Mindy A6F, A60, A700F; for T04024 Moonclever MC824H.

**24 Vdc version** with magnetic encoder.

### Perfect for intensive use,

compatible with the control unit Moonclever MC824H:

- simple programming, by means of a single key;
- self-learning of opening and closing limit positions;
- automatic fault diagnostics;
- programming of pause time;
- pedestrian pass door;
- deceleration on opening and closing;
- obstacle detection with dual technology;
- operation in event of power failure by means of optional rechargeable batteries (PS324);
- provision for connection of latest generation resistive sensitive edges.

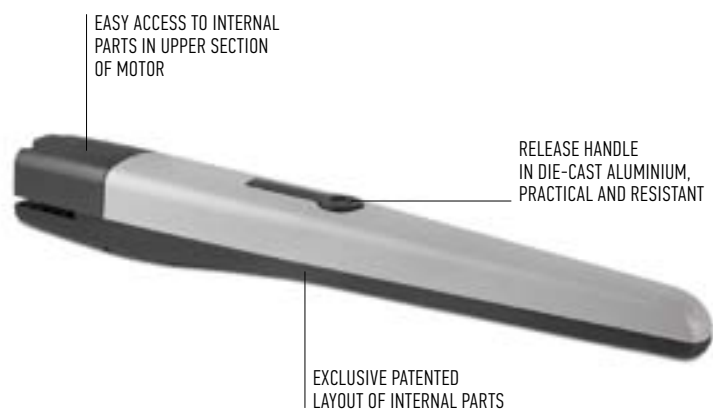

CODE	DESCRIPTION	PACK/PALLET
T04024	IRREVERSIBLE, 24 Vdc, WITH MAGNETIC ENCODER, MECHANICAL STOP ON OPENING	20
T04005	IRREVERSIBLE, 230 Vac, HIGH SPEED, WITH LIMIT SWITCH ON OPENING	20
T04006	IRREVERSIBLE, 230 Vac, HIGH SPEED, WITH LIMIT SWITCH ON OPENING AND CLOSING	20
T04015	IRREVERSIBLE, 230 Vac, LOW SPEED, WITH LIMIT SWITCH ON OPENING	20
T04605	REVERSIBLE, 230 Vac, HIGH SPEED, WITH LIMIT SWITCH ON OPENING	20

## TECHNICAL SPECIFICATIONS

CODE	T04024	T04005	T04006	T04015	T04605
<b>ELECTRICAL DATA</b>					
POWER SUPPLY (Vac 50 Hz)*	-	230			
POWER SUPPLY (Vdc)	24	-			
ABSORPTION (A)	5	1.5		1.3	
POWER (W)	120	340		300	
<b>PERFORMANCE DATA</b>					
SPEED (m/s)	0.016		0.013	0.016	
FORCE (N)	1800				
WORK CYCLE (CYCLES/HOUR)	95**	58	54	50	
<b>DIMENSIONAL AND GENERAL DATA</b>					
PROTECTION LEVEL (IP)	44				
WORKING TEMP. (°C MIN/MAX)	-20 ÷ +50				
DIMENSIONS (mm)	820x115x105 h				
WEIGHT (kg)	6				

\*60 Hz version available on request.

\*\* With optimal installation.

## UTILISATION LIMITS

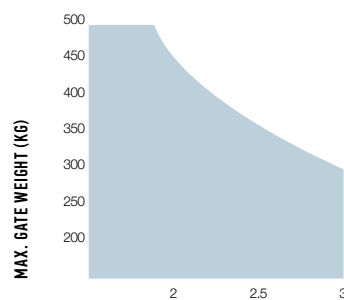

## DIMENSIONS

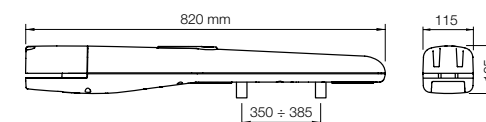

The shape, the height of the gate and the weather conditions can considerably reduce the values shown in the graph to the side. Use in windy areas 230 Vac models.

## ACCESSORIES

Total interchangeability with the series Moby: identical positions and fixing brackets



**PLA6**  
REAR BRACKET  
250 mm LONG.  
PC/PACK 1



**PLA14**  
SCREW-ADJUSTABLE  
REAR BRACKET.  
PC/PACK 2



**PLA15**  
SCREW-ADJUSTABLE  
FRONT BRACKET.  
PC/PACK 2



**PLA10**  
VERTICAL 12 V ELECTRIC  
LOCK (REQUIRED FOR GATES  
LONGER THAN 3 m).  
PC/PACK 1



**PLA11**  
HORIZONTAL 12 V ELECTRIC LOCK  
(REQUIRED FOR GATES  
LONGER THAN 3 m).  
PC/PACK 1



**PLA13**  
MECHANICAL TRAVEL STOPS  
FOR CLOSING OR OPENING  
MANOEUVRES.  
PC/PACK 4



**TS**  
SIGNBOARD.  
PC/PACK 1



- THE SOLAR POWER KIT SOLEMYO TO AUTOMATE GATES, GARAGE DOORS OR BARRIER GATES, INCLUDING THOSE LOCATED FAR FROM THE POWER MAINS AND WITHOUT THE NEED FOR COSTLY AND INVASIVE EXCAVATION WORK. SEE PAGE 171

## ACCESSORY

For 24 Vdc version



**PS324**  
24 V BATTERY  
WITH INTEGRATED  
BATTERY CHARGER.  
PC/PACK 1

## INSTALLATION DIAGRAM

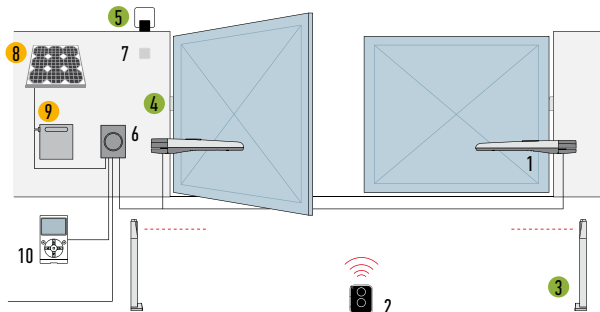

1. MOTOR
2. TRANSMITTER
3. PHOTOCELLS MOUNTED ON POSTS
4. PHOTOCELLS
5. FLASHING LIGHT
6. CONTROL UNIT
7. DIGITAL OR KEY SWITCHES
8. SYP SOLAR PANEL
9. PSY24 BATTERY BOX
10. 0-VIEW MULTIFUNCTION DISPLAY

- ACCESSORIES ALSO AVAILABLE FOR THE Solemyo Air Net System WIRELESS VERSION
- Solemyo SOLAR POWER ACCESSORIES

Nice recommends customers order products in pallets in order to facilitate storage and delivery, and ensure packs are uniform. The number of packs per single pallet has been specified for this reason. Approximate draft.

# TOONA 5

SOLEMYO OPERA BLUEBUS 24V 230V

## For swing gates with leaves up to 5 m.

Electromechanical gear motor, surface mounted.

Also available in 24 Vdc version, with magnetic encoder.

Ideal for residential and industrial use.

**Reliable:** durability thanks to the housing, made up of two tough aluminium shells with polyester paint finish; more resistant to atmospheric agents.

Internal moving parts completely in steel, light alloys and technopolymers.

**T05024I** ideal for intensive work load, thanks to the torque of 2200 Nm, can work on continuous duty on large sized gates.

**Silent:** patented layout of internal parts and lead nut in bronze.

### Generously sized and practical connection compartment:

rapid and easy access from above to internal parts located in the upper section of the motor.

### Simple installation and maintenance,

with built-in capacitor.

### Recommended control units:

Mindy A6F, A60, A700F; for T05024 and T05024I Moonclever MC824H.

**24 Vdc version** with magnetic encoder.

### Perfect for intensive use,

compatible with the control unit Moonclever MC824H:

- simple programming, by means of a single key;
- self-learning of opening and closing limit positions;
- automatic fault diagnostics;
- programming of pause time;
- pedestrian pass door;
- deceleration on opening and closing;
- obstacle detection with dual technology;
- operation in event of power failure by means of optional rechargeable batteries (PS324);
- provision for connection of latest generation resistive sensitive edges.

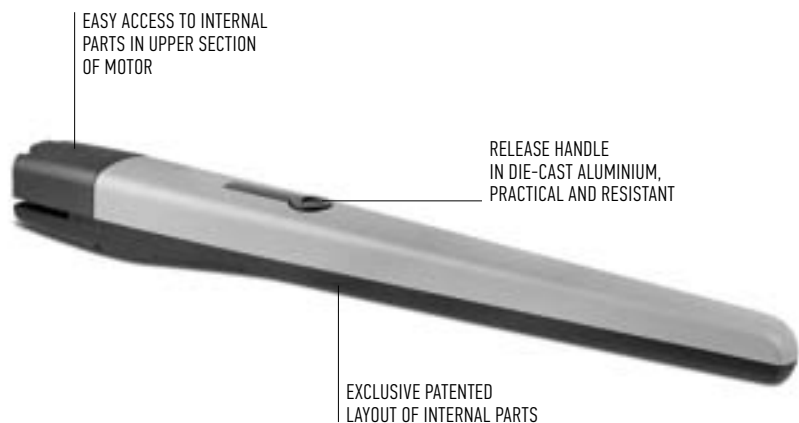

CODE	DESCRIPTION	PACK/PALLET
<b>T05024</b>	IRREVERSIBLE, 24 Vdc, WITH MAGNETIC ENCODER, MECHANICAL STOP ON OPENING	20
<b>T05024I</b>	IRREVERSIBLE, 24 Vdc, WITH MAGNETIC ENCODER, MECHANICAL STOP ON OPENING; FOR INTENSIVE USE	20
<b>T05015</b>	IRREVERSIBLE, 230 Vac, LOW SPEED, WITH LIMIT SWITCH ON OPENING	20
<b>T05016</b>	IRREVERSIBLE, 230 Vac, LOW SPEED, WITH LIMIT SWITCH ON OPENING AND CLOSING	20
<b>T05605</b>	REVERSIBLE, 230 Vac, HIGH SPEED, WITH LIMIT SWITCH ON OPENING	20

## TECHNICAL SPECIFICATIONS

CODE	T05024	T05024I	T05015	T05016	T05605
<b>ELECTRICAL DATA</b>					
POWER SUPPLY (Vac 50 Hz)*	-		230		
POWER SUPPLY (Vdc)	24		-		
ABSORPTION (A)	5		1.5		1.3
POWER (W)	120		340		300
<b>PERFORMANCE DATA</b>					
SPEED (m/s)	0.016		0.013		0.016
FORCE (N)	1800		2200		1800
WORK CYCLE (CYCLES/HOUR)	95**		75***		54
<b>DIMENSIONAL AND GENERAL DATA</b>					
PROTECTION LEVEL (IP)	44				
WORKING TEMP. (°C MIN/MAX)	-20 ÷ +50				
DIMENSIONS (mm)	965x115x105 h				
WEIGHT (kg)	7				

\*60 Hz version available on request.

\*\* With optimal installation.

\*\*\* The reduction in number of manoeuvres with respect to the version T05024 depends solely on the lower manoeuvre speed.

## UTILISATION LIMITS

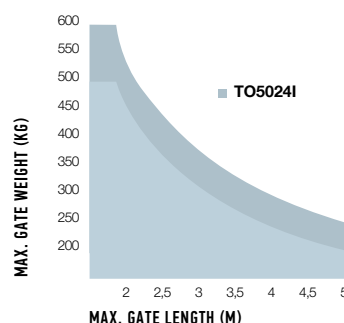

## DIMENSIONS

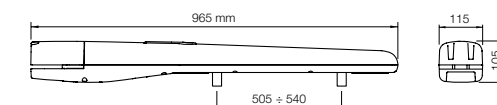

The shape, the height of the gate and the weather conditions can considerably reduce the values shown in the graph to the side. Use in windy areas 230 Vac models.



## ACCESSORIES

Total interchangeability with the series Moby: identical positions and fixing brackets



**PLA6**  
REAR BRACKET  
250 mm LONG.

PC/PACK 1



**PLA8**  
SCREW-ADJUSTABLE  
FRONT BRACKET.

PC/PACK 1



**PLA10**  
VERTICAL 12 V ELECTRIC  
LOCK (REQUIRED FOR GATES  
LONGER THAN 3 m).

PC/PACK 1



**PLA11**  
HORIZONTAL 12 V ELECTRIC  
LOCK (REQUIRED FOR GATES  
LONGER THAN 3 m).

PC/PACK 1



**PLA13**  
MECHANICAL TRAVEL STOPS  
FOR CLOSING AND OPENING  
MANOEUVRES.

PC/PACK 4



**TS**  
SIGNBOARD.

PC/PACK 1

## ACCESSORY

For 24 Vdc version



**PS324**  
24 V BATTERY  
WITH INTEGRATED  
BATTERY CHARGER.

PC/PACK 1

## INSTALLATION DIAGRAM

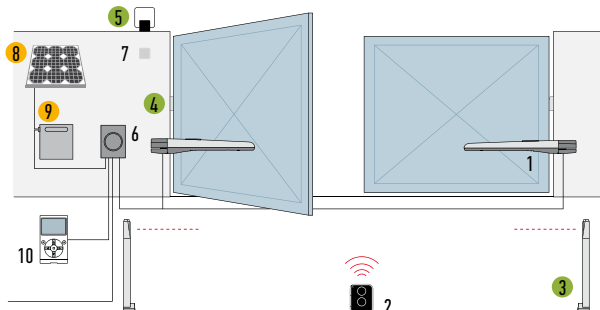

1. MOTOR
2. TRANSMITTER
3. PHOTOCELLS MOUNTED ON POSTS
4. PHOTOCELLS
5. FLASHING LIGHT
6. CONTROL UNIT
7. DIGITAL OR KEY SWITCHES
8. SYP SOLAR PANEL
9. PSY24 BATTERY BOX
10. 0-VIEW MULTIFUNCTION DISPLAY

- ACCESSORIES ALSO AVAILABLE FOR THE Solemyo Air Net System WIRELESS VERSION
- Solemyo SOLAR POWER ACCESSORIES

## KIT SOLEMYO



- THE SOLAR POWER KIT SOLEMYO TO AUTOMATE GATES, GARAGE DOORS OR BARRIER GATES, INCLUDING THOSE LOCATED FAR FROM THE POWER MAINS AND WITHOUT THE NEED FOR COSTLY AND INVASIVE EXCAVATION WORK. SEE PAGE 171

# TOONA 7

SOLEMYO OPERA BLUEBUS 24V

## For swing gates with leaves up to 7 m.

Electromechanical gear motor, surface mounted, powered at 24 Vdc, with magnetic encoder. Ideal for industrial installations, designed for intensive use.

**Reliable:** durability thanks to the housing, made up of two tough aluminium shells with polyester paint finish; more resistant to atmospheric agents.

Internal moving parts completely in steel, light alloys and technopolymers.

**Silent:** patented layout of internal parts and lead nut in bronze.

**Generously sized and practical connection compartment:** rapid and easy access from above to internal parts located in the upper section of the motor.

### Moonclever MC824H control unit:

- simple programming, by means of a single key;
- self-learning of opening and closing limit positions;
- automatic fault diagnostics;
- programming of pause time;
- pedestrian pass door;
- deceleration on opening and closing;
- obstacle detection with dual technology;
- operation in event of power failure by means of optional rechargeable batteries (PS324);
- provision for connection of latest generation resistive sensitive edges.

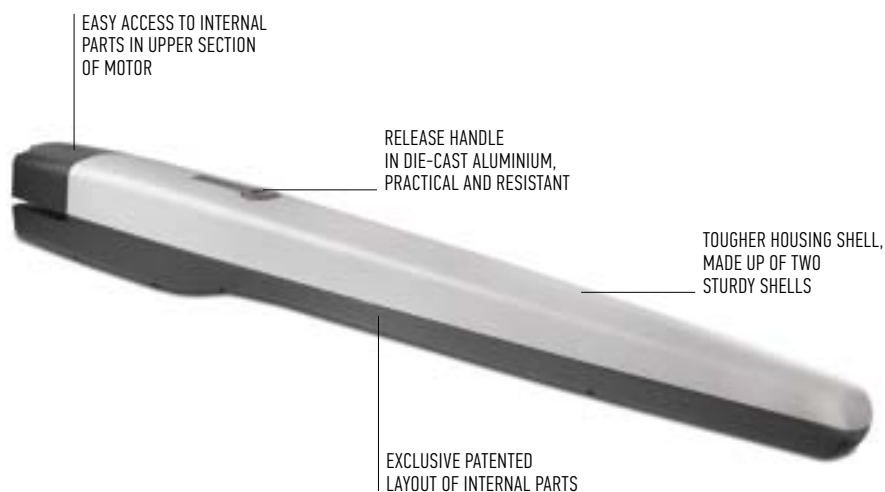

CODE	DESCRIPTION	PACK/PALLET
T07024	IRREVERSIBLE, 24 Vdc, WITH MAGNETIC ENCODER, MECHANICAL STOP ON OPENING AND CLOSING	20

### TECHNICAL SPECIFICATIONS

CODE	T07024
<b>ELECTRICAL DATA</b>	
POWER SUPPLY (Vac 50 Hz)	-
POWER SUPPLY (Vdc)	24
ABSORPTION (A)	5
POWER (W)	120
<b>PERFORMANCE DATA</b>	
SPEED (m/s)	0.013
FORCE (N)	2700
WORK CYCLE (CYCLES/HOUR)	41
<b>DIMENSIONAL AND GENERAL DATA</b>	
PROTECTION LEVEL (IP)	44
WORKING TEMP. (°C MIN/MAX)	-20 ÷ +50
DIMENSIONS (mm)	1200x128x150 h
WEIGHT (kg)	15

### UTILISATION LIMITS

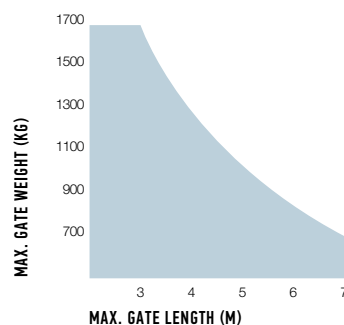

The shape, the height of the gate and the weather conditions can considerably reduce the values shown in the graph to the side.

### DIMENSIONS

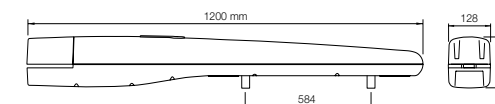

## ACCESSORIES



**PLA10**  
VERTICAL 12 V ELECTRIC  
LOCK (REQUIRED FOR GATES  
LONGER THAN 3 m).

PC/PACK 1



**PLA11**  
HORIZONTAL 12 V ELECTRIC LOCK  
(REQUIRED FOR GATES  
LONGER THAN 3 m).

PC/PACK 1



**TS**  
SIGNBOARD.

PC/PACK 1



**PS324**  
24 V BATTERY  
WITH INTEGRATED  
BATTERY CHARGER.

PC/PACK 1

## KIT SOLEMYO



● THE SOLAR POWER  
KIT SOLEMYO TO AUTOMATE  
GATES, GARAGE DOORS  
OR BARRIER GATES,  
INCLUDING THOSE LOCATED  
FAR FROM THE POWER MAINS  
AND WITHOUT THE NEED  
FOR COSTLY AND INVASIVE  
EXCAVATION WORK.  
SEE PAGE 171

## INSTALLATION DIAGRAM

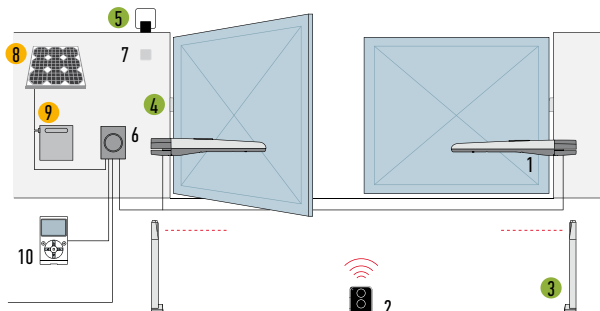

1. MOTOR
2. TRANSMITTER
3. PHOTOCELLS MOUNTED ON POSTS
4. PHOTOCELLS
5. FLASHING LIGHT
6. CONTROL UNIT
7. DIGITAL OR KEY SWITCHES
8. SYP SOLAR PANEL
9. PSY24 BATTERY BOX
10. 0-VIEW MULTIFUNCTION DISPLAY

- ACCESSORIES ALSO AVAILABLE FOR THE Solemyo Air Net System WIRELESS VERSION
- Solemyo SOLAR POWER ACCESSORIES

# TOONAKIT

SOLEMYO OPERA BLUEBUS 24V

**For swing gates with leaves up to 3 m,** ideal for residential use.

Electromechanical gear motor, surface mounted, powered at 24 Vdc, with magnetic encoder.

**Reliable:** durability thanks to the housing, made up of two tough aluminium shells with polyester paint finish; more resistant to atmospheric agents.

Internal moving parts completely in steel, light alloys and technopolymers.

**Silent:** patented layout of internal parts and lead nut in bronze.

**Generously sized and practical connection compartment:** rapid and easy access from above to internal parts located in the upper section of the motor.

**Ease of installation and maintenance.**

**Moonclever MC824H control unit:**

- simple programming, by means of a single key;
- self-learning of opening and closing limit positions;
- automatic fault diagnostics;
- programming of pause time;
- pedestrian pass door;
- deceleration on opening and closing;
- obstacle detection with dual technology;
- operation in event of power failure by means of optional rechargeable batteries (PS324);
- provision for connection of latest generation resistive sensitive edges.

CODE	DESCRIPTION	PACK/PALLET
TOONA4024KCE	KIT FOR SWING GATES WITH LEAVES UP TO 3 m, 24 Vdc, SURFACE MOUNTED	12

**N.B.** The content of the package may vary; consult the retailer.

## TECHNICAL SPECIFICATIONS

CODE	T04024
<b>ELECTRICAL DATA</b>	
POWER SUPPLY (Vdc)	24
ABSORPTION (A)	5
POWER (W)	120
<b>PERFORMANCE DATA</b>	
SPEED (m/s)	0.016
FORCE (N)	1800
WORK CYCLE (CYCLES/HOUR)	95*
<b>DIMENSIONAL AND GENERAL DATA</b>	
PROTECTION LEVEL (IP)	44
WORKING TEMP. (°C MIN/MAX)	-20 ÷ +50
DIMENSIONS (mm)	820x115x105 h
WEIGHT (kg)	6

\* With optimal installation.

## UTILISATION LIMITS

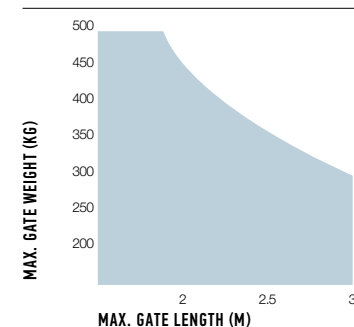

The shape, the height of the gate and the weather conditions can considerably reduce the values shown in the graph to the side.

## DIMENSIONS

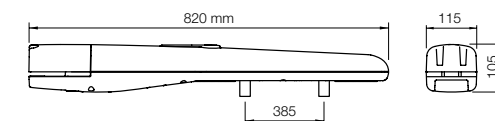

## THE KIT CONTAINS:

**T04024**  
2 ELECTROMECHANICAL IRREVERSIBLE GEAR MOTORS, SURFACE MOUNTED. WITH MECHANICAL STOP ON OPENING.



**0N2E**  
1 TRANSMITTER  
433.92 MHz, 2 CHANNELS.



**MC824H**  
1 CONTROL UNIT  
WITH OXI PLUG-IN RECEIVER.



**MOFB**  
1 COUPLE OF EXTERNAL  
PHOTOCELLS DESIGNED FOR  
CONNECTION BY NICE BLUEBUS.



**MOSE**  
1 KEY SELECTOR SWITCH FOR  
OUTDOOR INSTALLATION.



**MLBT**  
1 FLASHING LIGHT  
WITH INTEGRATED AERIAL.



**TS**  
1 SIGNBOARD.



## ACCESSORIES

Total interchangeability with the series Moby: identical positions and fixing brackets



**PLA6**  
REAR BRACKET  
250 mm LONG.  
PC/PACK 1



**PLA14**  
SCREW-ADJUSTABLE  
REAR BRACKET.  
PC/PACK 2



**PLA15**  
SCREW-ADJUSTABLE  
FRONT BRACKET.  
PC/PACK 2



**PLA10**  
VERTICAL 12 V ELECTRIC  
LOCK (REQUIRED FOR GATES  
LONGER THAN 3 m).  
PC/PACK 1



**PLA11**  
HORIZONTAL 12 V ELECTRIC LOCK  
(REQUIRED FOR GATES  
LONGER THAN 3 m).  
PC/PACK 1



**PLA13**  
MECHANICAL TRAVEL STOPS  
FOR CLOSING AND OPENING  
MANOEUVRES.  
PC/PACK 4



**PS324**  
24 V BATTERY  
WITH INTEGRATED  
BATTERY CHARGER.  
PC/PACK 1



● THE SOLAR POWER  
KIT SOLEMYO TO AUTOMATE  
GATES, GARAGE DOORS  
OR BARRIER GATES,  
INCLUDING THOSE LOCATED  
FAR FROM THE POWER MAINS  
AND WITHOUT THE NEED  
FOR COSTLY AND INVASIVE  
EXCAVATION WORK.  
SEE PAGE 171

## INSTALLATION DIAGRAM

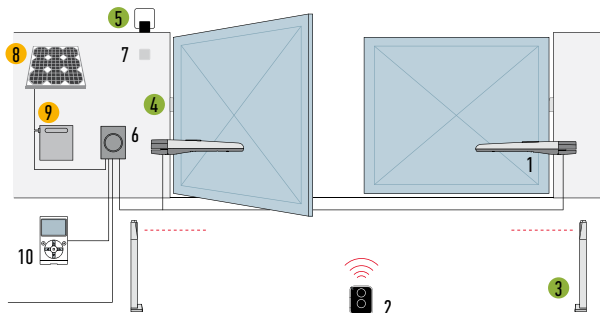

1. MOTOR
2. TRANSMITTER
3. PHOTOCELLS MOUNTED ON POSTS
4. PHOTOCELLS
5. FLASHING LIGHT
6. CONTROL UNIT
7. DIGITAL OR KEY SWITCHES
8. SYP SOLAR PANEL
9. PSY24 BATTERY BOX
10. 0-VIEW MULTIFUNCTION DISPLAY

- ACCESSORIES ALSO AVAILABLE FOR THE Solemyo Air Net System WIRELESS VERSION
- Solemyo SOLAR POWER ACCESSORIES



Nice recommends customers order products in pallets in order to facilitate storage and delivery, and ensure packs are uniform. The number of packs per single pallet has been specified for this reason. Approximate draft.

# WINGOKIT

230V

**For swing gates with leaves up to 2 m, surface mounted.**

**Reliable and silent:**

patented layout of internal parts, fewer moving parts.

**Easy to install:** after the gear motor has been assembled, all electrical connections are made from above.

**Built-in capacitor.**

**User-friendly release** with personalised Nice key or standard lock (optional).

**Pre-assembled,** travel stops on opening.

**A60 control unit** for two 230 Vac motors with electronic clutch and slowdown, IP55 casing.

CODE	DESCRIPTION	PACK/PALLET
WINGOKCE/A60	KIT FOR SWING GATES WITH LEAVES UP TO 2 m, SURFACE MOUNTED	12

**N.B.** The content of the package may vary: consult the retailer.

**TECHNICAL SPECIFICATIONS**

CODE	WG4000
<b>ELECTRICAL DATA</b>	
POWER SUPPLY (Vac 50 Hz)*	230
ABSORPTION (A)	1.5
POWER (W)	200
<b>PERFORMANCE DATA</b>	
SPEED (m/s)	0.016
FORCE (N)	1500
WORK CYCLE (CYCLES/HOUR)	30
<b>DIMENSIONAL AND GENERAL DATA</b>	
PROTECTION LEVEL (IP)	44
WORKING TEMP. (°C MIN/MAX)	-20 ÷ +50
DIMENSIONS (mm)	770x98x95 h
WEIGHT (kg)	6

\*60 Hz version available on request.

**UTILISATION LIMITS**

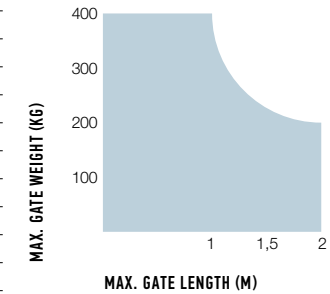

**DIMENSIONS**

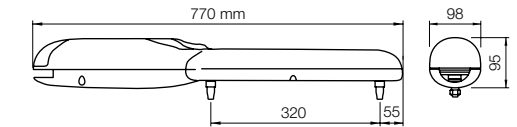

**THE KIT CONTAINS:**

**WG4000**  
2 SURFACE-MOUNTED ELECTROMECHANICAL GEAR MOTORS, WITH NICE KEY RELEASE AND MECHANICAL STOP ON OPENING.

**FLO2RE**  
1 TRANSMITTER  
433.92 MHz, 2 CHANNELS.

**A60**  
1 CONTROL UNIT A60  
WITH SMXI PLUG-IN RECEIVER.

**MOF**  
1 PAIR OF PHOTOCELLS  
FOR OUTDOOR INSTALLATION.

**MOSE**  
1 KEY SELECTOR SWITCH  
FOR OUTDOOR INSTALLATION.

**MLT**  
1 FLASHING LIGHT WITH  
INTEGRATED AERIAL.

**TS**  
1 SIGNBOARD.



## ACCESSORIES



**PLA14**  
SCREW-ADJUSTABLE  
REAR BRACKET.

PC/PACK 2



**PLA15**  
SCREW-ADJUSTABLE  
FRONT BRACKET.

PC/PACK 2



**CM-B**  
PAWL WITH TWO METAL  
RELEASE KEYS.

## INSTALLATION DIAGRAM

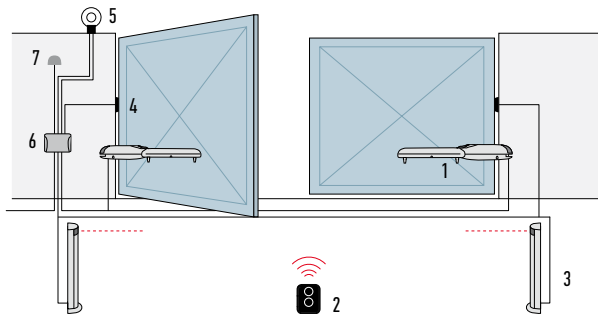

1. MOTOR
2. TRANSMITTER
3. PHOTOCELLS MOUNTED ON POSTS
4. PHOTOCELLS
5. FLASHING LIGHT
6. CONTROL UNIT
7. DIGITAL OR KEY SWITCHES



# WINGOKIT 4024

SOLEMYO 24V

**For swing gates with leaves up to 2 m, surface mounted.**  
24 Vdc electromechanical gear motor.

**Reliable and silent:**  
patented layout of internal parts, fewer moving parts.

**Easy to install:** after the gear motor has been assembled, all electrical connections are made from above.

**User-friendly release** with personalised Nice key or standard lock (optional).

**Pre-assembled,** travel stops on opening.

## Moonclever control unit MC424L:

- simple programming, by means of a single key;
- clutch with anti-crush safety feature;
- automatic memorization of limit switches on opening and closing with self-learning function;
- programming of pause time;
- pedestrian pass door;
- deceleration on opening and closing;
- obstacle detection system;
- can be linked to the 8.2 KOhm resistive sensitive edge;
- continues to work even during power failures using optional (PS124) batteries that fit inside the control unit.

CODE	DESCRIPTION	PACK/PALLET
WINGO4024KCE	KIT FOR SWING GATES WITH LEAVES UP TO 2 m, 24 Vdc, SURFACE MOUNTED	12

**N.B.** The content of the package may vary: consult the retailer.

## TECHNICAL SPECIFICATIONS

CODE	WG4024
<b>ELECTRICAL DATA</b>	
POWER SUPPLY (Vdc)	24
ABSORPTION (A)	3.5
POWER (W)	85
<b>PERFORMANCE DATA</b>	
SPEED (m/s)	0.018
FORCE (N)	1500
WORK CYCLE (CYCLES/HOUR)	30
<b>DIMENSIONAL AND GENERAL DATA</b>	
PROTECTION LEVEL (IP)	44
WORKING TEMP. (°C MIN/MAX)	-20 ÷ +50
DIMENSIONS (mm)	770x98x95 h
WEIGHT (kg)	17

## UTILISATION LIMITS

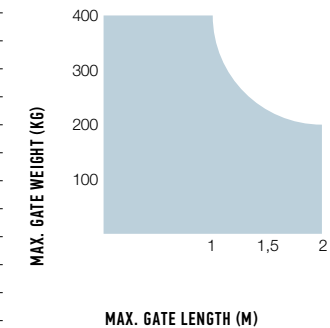

## DIMENSIONS

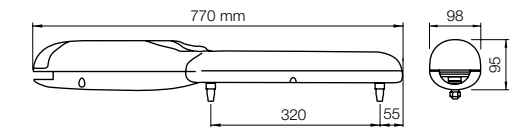

## THE KIT CONTAINS:

**WG4024**  
2 SURFACE-MOUNTED ELECTROMECHANICAL GEAR MOTORS, WITH NICE KEY RELEASE AND MECHANICAL STOP ON OPENING.

**FL02RE**  
1 TRANSMITTER 433.92 MHz, 2 CHANNELS.

**MC424L**  
1 CONTROL UNIT WITH SMXI PLUG-IN RECEIVER.

**MOF**  
1 PAIR OF PHOTOCELLS FOR OUTDOOR INSTALLATION.

**MOSE**  
1 KEY SELECTOR SWITCH FOR OUTDOOR INSTALLATION.

**ML24T**  
1 FLASHING LIGHT WITH INTEGRATED AERIAL.

**TS**  
1 SIGNBOARD.





**ACCESSORIES**



**PS124**  
24 V BATTERY  
WITH INTEGRATED  
BATTERY CHARGER.  
PC/PACK 1



**PLA14**  
SCREW-ADJUSTABLE  
REAR BRACKET.  
PC/PACK 2



**PLA15**  
SCREW-ADJUSTABLE  
FRONT BRACKET.  
PC/PACK 2



**CM-B**  
PAWL WITH TWO METAL  
RELEASE KEYS.



**PLA10**  
VERTICAL 12 V ELECTRIC  
LOCK.  
PC/PACK 1



**PLA11**  
HORIZONTAL 12 V ELECTRIC  
LOCK.  
PC/PACK 1

**KIT SOLEMYO**



● THE SOLAR POWER KIT SOLEMYO TO AUTOMATE GATES, GARAGE DOORS OR BARRIER GATES, INCLUDING THOSE LOCATED FAR FROM THE POWER MAINS AND WITHOUT THE NEED FOR COSTLY AND INVASIVE EXCAVATION WORK. SEE PAGE 171

**INSTALLATION DIAGRAM**

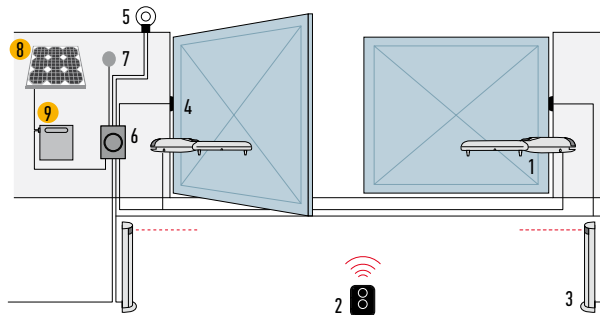

- 1. MOTOR
- 2. TRANSMITTER
- 3. PHOTOCELLS MOUNTED ON POSTS
- 4. PHOTOCELLS
- 5. FLASHING LIGHT
- 6. CONTROL UNIT
- 7. DIGITAL OR KEY SWITCHES
- 8. SYP SOLAR PANEL
- 9. PSY24 BATTERY BOX

● Solemyo SOLAR POWER ACCESSORIES



Nice recommends customers order products in pallets in order to facilitate storage and delivery, and ensure packs are uniform. The number of packs per single pallet has been specified for this reason. Approximate draft.

# WINGO5KIT

230V

**For swing gates with leaves up to 3.5 m, surface mounted.**

**Reliable and silent:**

patented layout of internal parts, fewer moving parts.

**Easy to install:** after the gear motor has been assembled, all electrical connections are made from above.

**Built-in capacitor.**

**User-friendly release** with personalised Nice key or standard lock (optional).

**Pre-assembled,** travel stops on opening.

**A60 control unit** for two 230 Vac motors with electronic clutch and slowdown, IP55 casing.

**THE KIT CONTAINS:**

**WG5000**

2 SURFACE-MOUNTED ELECTROMECHANICAL GEAR MOTORS, WITH NICE KEY RELEASE AND MECHANICAL STOP ON OPENING.

**FLO2RE**

1 TRANSMITTER 433.92 MHz, 2 CHANNELS.

**A60**

1 CONTROL UNIT A60 WITH SMXI PLUG-IN RECEIVER.

**MOF**

1 PAIR OF PHOTOCELLS FOR OUTDOOR INSTALLATION.

**MOSE**

1 KEY SELECTOR SWITCH FOR OUTDOOR INSTALLATION.

**MLT**

1 FLASHING LIGHT WITH INTEGRATED AERIAL.

**TS**

1 SIGNBOARD.



CODE	DESCRIPTION	PACK/PALLET
WINGO5KCE	KIT FOR SWING GATES WITH LEAVES UP TO 3.5 m, SURFACE MOUNTED	12

**N.B.** The content of the package may vary; consult the retailer.

**TECHNICAL SPECIFICATIONS**

CODE	WG5000
<b>ELECTRICAL DATA</b>	
POWER SUPPLY (Vac 50 Hz)*	230
ABSORPTION (A)	1.5
POWER (W)	200
<b>PERFORMANCE DATA</b>	
SPEED (m/s)	0.013
FORCE (N)	1700
WORK CYCLE (CYCLES/HOUR)	30
<b>DIMENSIONAL AND GENERAL DATA</b>	
PROTECTION LEVEL (IP)	44
WORKING TEMP. (°C MIN/MAX)	-20 ÷ +50
DIMENSIONS (mm)	920x98x95 h
WEIGHT (kg)	6

\*60 Hz version available on request.

**UTILISATION LIMITS**

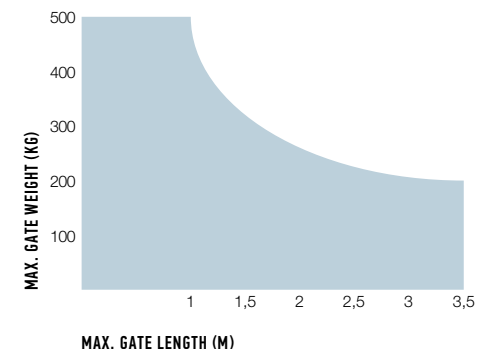

**DIMENSIONS**

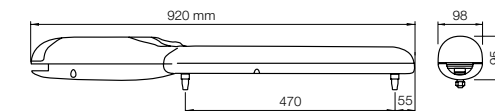

## ACCESSORIES



**PLA6**  
REAR BRACKET  
250 mm LONG.  
PC/PACK 1



**PLA8**  
SCREW-ADJUSTABLE  
FRONT BRACKET.  
PC/PACK 1



**CM-B**  
PAWL WITH TWO METAL  
RELEASE KEYS.



**PLA10**  
VERTICAL 12 V ELECTRIC  
LOCK (REQUIRED FOR GATES  
LONGER THAN 3 m).  
PC/PACK 1



**PLA11**  
HORIZONTAL 12 V ELECTRIC  
LOCK (REQUIRED FOR GATES  
LONGER THAN 3 m).  
PC/PACK 1

## INSTALLATION DIAGRAM

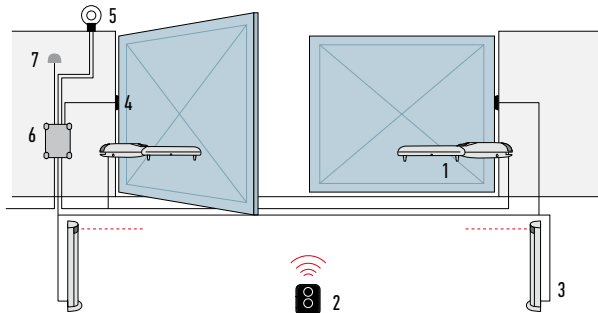

1. MOTOR
2. TRANSMITTER
3. PHOTOCELLS MOUNTED ON POSTS
4. PHOTOCELLS
5. FLASHING LIGHT
6. CONTROL UNIT
7. DIGITAL OR KEY SWITCHES



# WINGOKIT 5024

SOLEMYO 24V

**For swing gates with leaves up to 3.5 m, surface mounted.**  
24 Vdc electromechanical gear motor.

**Reliable and silent:**  
patented layout of internal parts, fewer moving parts.

**Easy to install:** after the gear motor has been assembled, all electrical connections are made from above.

**User-friendly release** with personalised Nice key or standard lock (optional).

**Pre-assembled,** travel stops on opening.

## Moonclever control unit MC424L:

- simple programming, by means of a single key;
- clutch with anti-crush safety feature;
- automatic memorization of limit switches on opening and closing with self-learning function;
- programming of pause time;
- pedestrian pass door;
- deceleration on opening and closing;
- obstacle detection system;
- can be linked to the 8.2 KOhm resistive sensitive edge;
- continues to work even during power failures using optional (PS124) batteries that fit inside the control unit.

CODE	DESCRIPTION	PACK/PALLET
WINGO5024KCE	KIT FOR SWING GATES WITH LEAVES UP TO 3.5 m, 24 Vdc, SURFACE MOUNTED	12

**N.B.** The content of the package may vary: consult the retailer.

## TECHNICAL SPECIFICATIONS

CODE	WG5024
<b>ELECTRICAL DATA</b>	
POWER SUPPLY (Vdc)	24
ABSORPTION (A)	3.5
POWER (W)	85
<b>PERFORMANCE DATA</b>	
SPEED (m/s)	0.016
FORCE (N)	1500
WORK CYCLE (CYCLES/HOUR)	30
<b>DIMENSIONAL AND GENERAL DATA</b>	
PROTECTION LEVEL (IP)	44
WORKING TEMP. (°C MIN/MAX)	-20 ÷ +50
DIMENSIONS (mm)	920x98x95 h
WEIGHT (kg)	18

## UTILISATION LIMITS

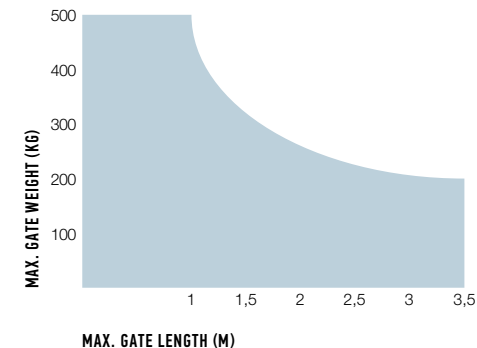

## DIMENSIONS

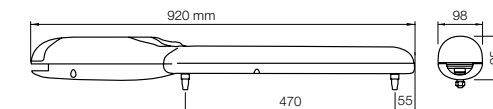

## THE KIT CONTAINS:

**WG5024**  
2 SURFACE-MOUNTED ELECTROMECHANICAL GEAR MOTORS, WITH NICE KEY RELEASE AND MECHANICAL STOP ON OPENING.

**FLO2RE**  
1 TRANSMITTER 433.92 MHz, 2 CHANNELS.

**MC424L**  
1 CONTROL UNIT WITH SMXI PLUG-IN RECEIVER.

**MOF**  
1 PAIR OF PHOTOCELLS FOR OUTDOOR INSTALLATION.

**MOSE**  
1 KEY SELECTOR SWITCH FOR OUTDOOR INSTALLATION.

**ML24T**  
1 FLASHING LIGHT WITH INTEGRATED AERIAL.

**TS**  
1 SIGNBOARD.



## ACCESSORIES



**PS124**  
24 V BATTERY  
WITH INTEGRATED  
BATTERY CHARGER.  
PC/PACK 1



**PLA6**  
REAR BRACKET  
250 mm LONG.  
PC/PACK 1



**PLA8**  
SCREW-ADJUSTABLE  
FRONT BRACKET.  
PC/PACK 1



**CM-B**  
PAWL WITH TWO METAL  
RELEASE KEYS.



**PLA10**  
VERTICAL 12 V ELECTRIC  
LOCK (REQUIRED FOR GATES  
LONGER THAN 3 m).  
PC/PACK 1



**PLA11**  
HORIZONTAL 12 V ELECTRIC  
LOCK (REQUIRED FOR GATES  
LONGER THAN 3 m).  
PC/PACK 1



- THE SOLAR POWER KIT SOLEMYO TO AUTOMATE GATES, GARAGE DOORS OR BARRIER GATES, INCLUDING THOSE LOCATED FAR FROM THE POWER MAINS AND WITHOUT THE NEED FOR COSTLY AND INVASIVE EXCAVATION WORK. SEE PAGE 171

## INSTALLATION DIAGRAM

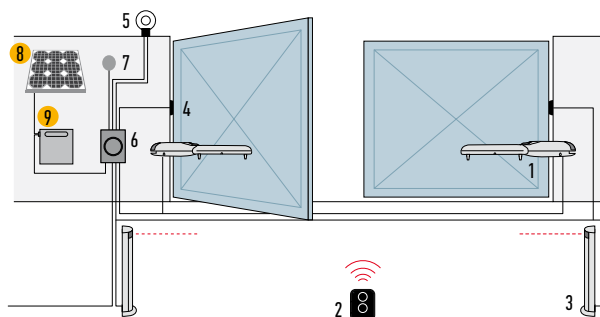

1. MOTOR
2. TRANSMITTER
3. PHOTOCELLS MOUNTED ON POSTS
4. PHOTOCELLS
5. FLASHING LIGHT
6. CONTROL UNIT
7. DIGITAL OR KEY SWITCHES
8. SYP SOLAR PANEL
9. PSY24 BATTERY BOX

● Solemyo SOLAR POWER ACCESSORIES



# WALKYKIT 1024

SOLEMYO OPERA BLUEBUS 24V

**For swing gates with leaves up to 1.8 m.**  
Especially suited to gates in wood or PVC.  
Irreversible electromechanical gear motor at 24 Vdc, with articulated arm.

**Ultra compact:** ideal for pedestrian gates, recommended for small posts (width 8 cm).

**Safe:** thanks to the irreversible motor and anti-shear arm with built-in mechanical stop on closure (with installation of entire arm).

**Practical:** the articulated arm enables installation in specific conditions, such as in the presence of small walls or obstacles adjacent to the post.

**Quick:** no waiting in front of the gate, just 7 seconds to open or close (in optimal installation conditions, with reduced arm and 90° opening).

**Convenient:** incorporable flashing LED indicator, with courtesy light function (WLT, optional); rapid motor release for manual movement of the gate.

**Built-in control unit:**

- simple programming;
- self-learning of opening and closing limit positions;
- automatic fault diagnostics;
- programming of pause time;
- pedestrian pass door;
- deceleration on opening and closing;
- provision for connection of latest generation resistive sensitive edges.

**No black out:** operation in the event of a power failure by means of optional batteries (PS424) housed inside the motor.

CODE	DESCRIPTION	PACK/PALLET
WALKY1024KCE	KIT FOR SWING GATES WITH LEAVES UP TO 1.8 m, 24 Vdc, SURFACE MOUNTED	18

**N.B.** The content of the package may vary; consult the retailer.

**TECHNICAL SPECIFICATIONS**

CODE	WL1024C
<b>ELECTRICAL DATA</b>	
POWER SUPPLY (Vac 50/60 Hz)	230
POWER SUPPLY (Vdc)	-
ABSORPTION (A)	0.8
POWER (W)	120
<b>PERFORMANCE DATA</b>	
SPEED (rpm)	1.5 - 2.2
TORQUE (Nm)	120
WORK CYCLE (CYCLES/HOUR)	50
<b>DIMENSIONAL AND GENERAL DATA</b>	
PROTECTION LEVEL (IP)	44
WORKING TEMP. (°C MIN/MAX)	-20° ÷ +50°
DIMENSIONS (mm)	90x125x385 h
WEIGHT (kg)	4,8

**DIMENSIONS**

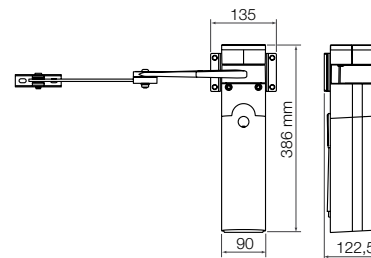

**UTILISATION LIMITS**

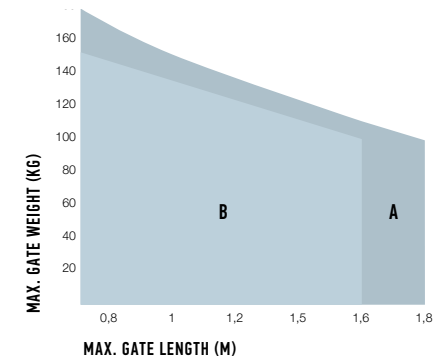
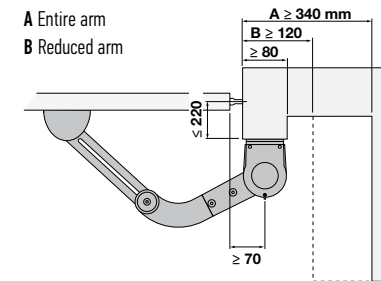

The shape, the height of the gate and the weather conditions can considerably reduce the values shown in the graph to the side.

**THE KIT CONTAINS:**



**WL1024C**  
1 ELECTROMECHANICAL GEAR MOTOR, SURFACE MOUNTED, WITH BUILT-IN CONTROL UNIT AND OXI PLUG-IN RECEIVER.

**ON2E**  
1 TRANSMITTER  
433.92 MHz, 2 CHANNELS.



**TS**  
1 SIGNBOARD.



**ACCESSORIES**

**KIT SOLEMYO**



**WLA1**  
SPARE CONTROL UNIT,  
FOR WL1024C.



**PS424**  
BUFFER BATTERY.  
PC/PACK 1



**PLA10**  
VERTICAL 12 V ELECTRIC  
LOCK (REQUIRED FOR GATES  
LONGER THAN 3 m).  
PC/PACK 1



**PLA11**  
HORIZONTAL 12 V ELECTRIC  
LOCK (REQUIRED FOR GATES  
LONGER THAN 3 m).  
PC/PACK 1



● THE SOLAR POWER KIT SOLEMYO TO AUTOMATE GATES, GARAGE DOORS OR BARRIER GATES, INCLUDING THOSE LOCATED FAR FROM THE POWER MAINS AND WITHOUT THE NEED FOR COSTLY AND INVASIVE EXCAVATION WORK. SEE PAGE 171



**WLT**  
MULTI-FUNCTION LED  
INDICATOR.  
SEE PAGE 187  
PC/PACK 1

**INSTALLATION DIAGRAM**

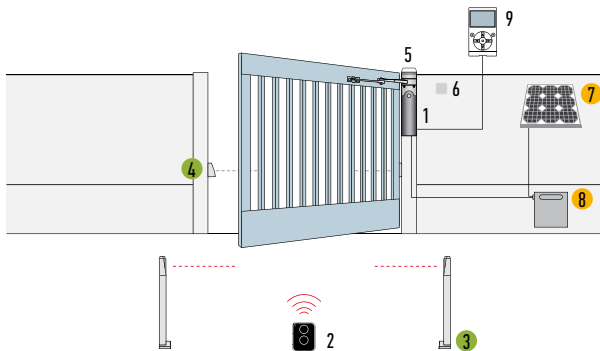

1. MOTOR
2. TRANSMITTER
3. PHOTOCELLS MOUNTED ON POSTS
4. PHOTOCELLS
5. FLASHING LIGHT
6. DIGITAL OR KEY SWITCHES
7. SYP SOLAR PANEL
8. PSY24 BATTERY BOX
9. 0-VIEW MULTIFUNCTION DISPLAY

- ACCESSORIES ALSO AVAILABLE FOR THE Solemyo Air Net System WIRELESS VERSION
- Solemyo SOLAR POWER ACCESSORIES



Nice recommends customers order products in pallets in order to facilitate storage and delivery, and ensure packs are uniform. The number of packs per single pallet has been specified for this reason. Approximate draft.

# WALKYKIT 2024

SOLEMYO OPERA BLUEBUS 24V

**For swing gates with leaves up to 1.8 m.**  
Especially suited to gates in wood or PVC.  
Irreversible electromechanical gear motor at 24 Vdc, with articulated arm.

**Ultra compact:** ideal for pedestrian gates, recommended for small posts (width 8 cm).

**Safe:** thanks to the irreversible motor and anti-shear arm with built-in mechanical stop on closure (with installation of entire arm).

**Practical:** the articulated arm enables installation in specific conditions, such as in the presence of small walls or obstacles adjacent to the post.

**Quick:** no waiting in front of the gate, just 7 seconds to open or close (in optimal installation conditions, with reduced arm and 90° opening).

**Convenient:** incorporable flashing LED indicator, with courtesy light function (WLT, optional); rapid motor release for manual movement of the gate.

**Built-in control unit:**

- simple programming;
- self-learning of opening and closing limit positions;
- automatic fault diagnostics;
- programming of pause time;
- pedestrian pass door;
- deceleration on opening and closing;
- provision for connection of latest generation resistive sensitive edges.

**No black out:** operation in the event of a power failure by means of optional batteries (PS424) housed inside the motor.

CODE	DESCRIPTION	PACK/PALLET
WALKY2024KCE	KIT FOR SWING GATES WITH LEAVES UP TO 1.8 m, 24 Vdc, WITH ARTICULATED ARM, SURFACE MOUNTED	18

**N.B.** The content of the package may vary: consult the retailer.

**TECHNICAL SPECIFICATIONS**

CODE	WL1024C	WL1024
<b>ELECTRICAL DATA</b>		
POWER SUPPLY (Vac 50/60 Hz)	230	-
POWER SUPPLY (Vdc)	-	24
ABSORPTION (A)	0.8	2
POWER (W)	120	30
<b>PERFORMANCE DATA</b>		
SPEED (rpm)	1.5 - 2.2	
TORQUE (Nm)	120	
WORK CYCLE (CYCLES/HOUR)	50	
<b>DIMENSIONAL AND GENERAL DATA</b>		
PROTECTION LEVEL (IP)	44	
WORKING TEMP. (°C MIN/MAX)	-20° ÷ +50°	
DIMENSIONS (mm)	90x125x385 h	
WEIGHT (kg)	4,8	4,3

**DIMENSIONS**

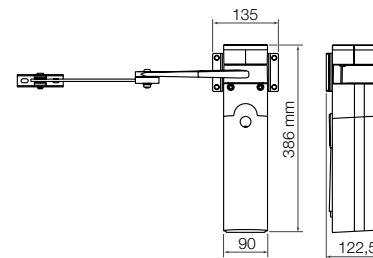

**UTILISATION LIMITS**

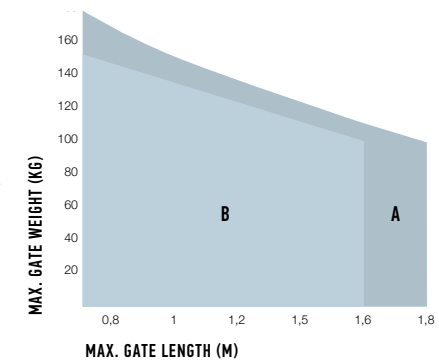
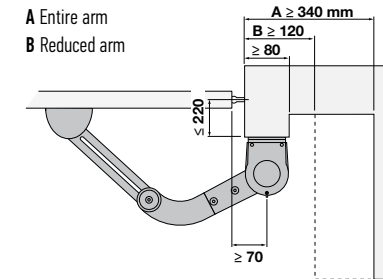

The shape, the height of the gate and the weather conditions can considerably reduce the values shown in the graph to the side.

**THE KIT CONTAINS:**



**WL1024C + WL1024**  
2 ELECTROMECHANICAL GEAR MOTORS, SURFACE MOUNTED.  
WL1024C (WITH CONTROL UNIT AND OXI PLUG-IN RECEIVER), WL1024 (WITHOUT CONTROL UNIT).

**ON2E**  
1 TRANSMITTER  
433.92 MHz, 2 CHANNELS.



**MOFB**  
1 COUPLE OF EXTERNAL PHOTOCELLS DESIGNED FOR CONNECTION FOR NICE BLUEBUS.



**MOSE**  
1 KEY SELECTOR SWITCH FOR OUTDOOR INSTALLATION.



**WLT**  
1 FLASHING LIGHT.



**TS**  
1 SIGNBOARD.





## ACCESSORIES



**WLA1**  
SPARE CONTROL UNIT,  
FOR WL1024C.



**PS424**  
BUFFER BATTERY.  
PC/PACK 1



**PLA10**  
VERTICAL 12 V ELECTRIC  
LOCK (REQUIRED FOR GATES  
LONGER THAN 3 m).  
PC/PACK 1



**PLA11**  
HORIZONTAL 12 V ELECTRIC LOCK  
(REQUIRED FOR GATES  
LONGER THAN 3 m).  
PC/PACK 1



**WLT**  
MULTI-FUNCTION LED  
INDICATOR.  
SEE PAGE 187  
PC/PACK 1

## KIT SOLEMYO



- THE SOLAR POWER KIT SOLEMYO TO AUTOMATE GATES, GARAGE DOORS OR BARRIER GATES, INCLUDING THOSE LOCATED FAR FROM THE POWER MAINS AND WITHOUT THE NEED FOR COSTLY AND INVASIVE EXCAVATION WORK. SEE PAGE 171

## INSTALLATION DIAGRAM

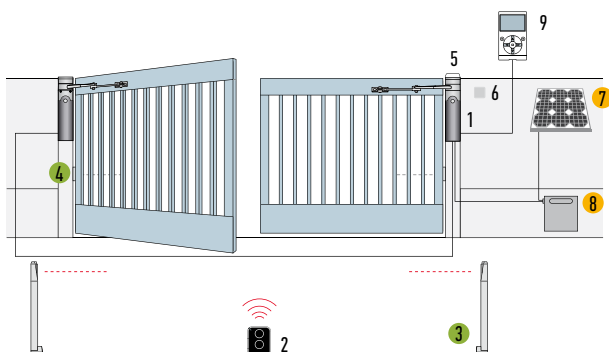

1. MOTOR
2. TRANSMITTER
3. PHOTOCELLS MOUNTED ON POSTS
4. PHOTOCELLS
5. FLASHING LIGHT
6. DIGITAL OR KEY SWITCHES
7. SYP SOLAR PANEL
8. PSY24 BATTERY BOX
9. O-VIEW MULTIFUNCTION DISPLAY

- ACCESSORIES ALSO AVAILABLE FOR THE Solemyo Air Net System WIRELESS VERSION
- Solemyo SOLAR POWER ACCESSORIES



## For swing gates with leaves up to 2.4 m, ideal for large columns.

Irreversible electromechanical 24 Vdc gear motor with articulated arm, surface mounted. Ideal for intensive use.

Two irreversible 24 Vdc motors with micrometric adjustment mechanical stops on opening and closing: with built-in control unit (H07124) and without control unit (H07224).

**Powerful** thanks to the 250 Nm torque.

**Resistant and compact:** 180 mm in width, ideal for any kind of post. Small shockproof body with aluminium base.

**Sturdy, aluminium anti-shearing arm.**

**Easy to install:** thanks to the new fixing bracket with quick connector for the motor. No welding.

**Sophisticated electronics with the built-in control unit,** just 3 keys to manage all programming operations:

- obstacle detection and possibility of connecting to 8.2 KOhm sensitive edge, fototest;
- automatic fault diagnostics;
- memorisation of opening and closing travel limits in self-learning mode;
- possibility of configuring the stop input in self-learning mode, NO, NC and the latest generation 8.2 KOhm resistive sensitive edges;
- deceleration on opening and closing;
- simple connection of pairs of additional photocells, foto2;
- programming of pause time;
- pedestrian open and partial open;
- clutch with anti-crushing safety mechanism.

### Energy saving with no black outs:

3 standby modes to reduce mains consumption, or battery power consumption if connected to the Solemyo kit.

Operation in the event of a power failure thanks to the optional batteries (PS124).

**Everything under control:** thanks to compatibility for operation with Opera system BUS T4, the unit can be used to expand the options of programming, control and diagnostics of the automation on site and remotely.

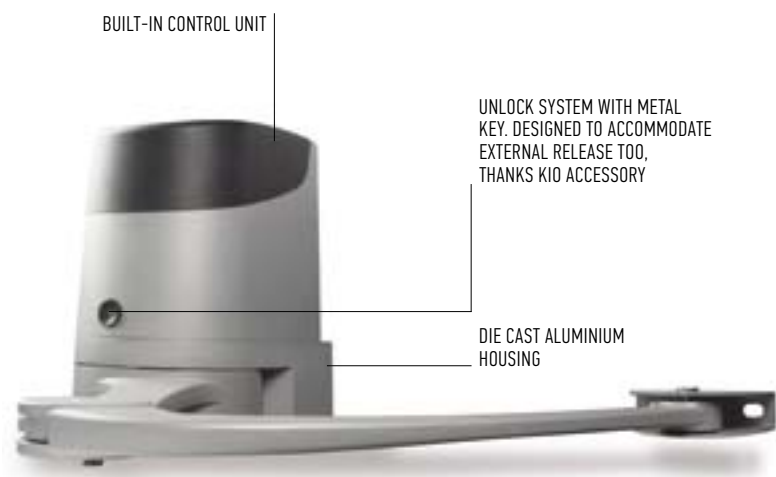

CODE	DESCRIPTION	PACK/PALLET
<b>H07124</b>	IRREVERSIBLE 24 Vdc, COMPLETE WITH ARTICULATED ARM AND BUILT-IN CONTROL UNIT	12
<b>H07224</b>	IRREVERSIBLE 24 Vdc, COMPLETE WITH ARTICULATED ARM WITHOUT CONTROL UNIT	12

**N.B.** The content of the package may vary: consult the retailer.

### TECHNICAL SPECIFICATIONS

CODE	H07124	H07224
<b>ELECTRICAL DATA</b>		
POWER SUPPLY (Vac 50/60 Hz)	230	-
POWER SUPPLY (Vdc)	-	24
ABSORPTION (A)	1.3	4
POWER (W)	280	100
<b>PERFORMANCE DATA</b>		
SPEED (rpm)		1.68
TORQUE (Nm)		250
WORK CYCLE (CYCLES/HOUR)		35
<b>DIMENSIONAL AND GENERAL DATA</b>		
PROTECTION LEVEL (IP)		54
WORKING TEMP. (°C MIN/MAX)		-20 ÷ +50
DIMENSIONS (mm)		252x180x290 h
WEIGHT (kg)	9	6.5

\* Version without control unit, only if associated with PP7124

### UTILISATION LIMITS

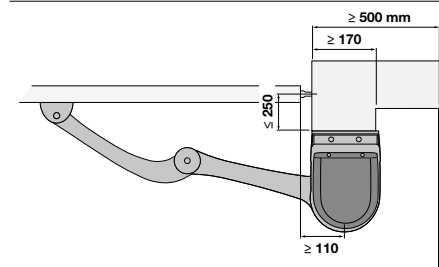

### DIMENSIONS

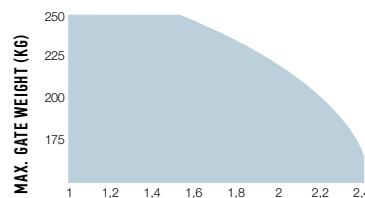
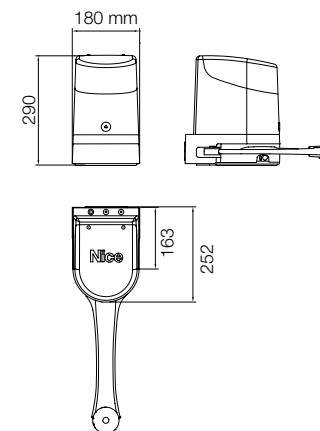

### MAX. GATE LENGTH (M)

The shape, the height of the gate and the weather conditions can considerably reduce the values shown in the graph to the side.



**POA3**  
SPARE CONTROL UNIT  
FOR HO7174.



**PS124**  
24 V BATTERY  
WITH INTEGRATED  
BATTERY CHARGER.  
PC/PACK 1



**PLA10**  
VERTICAL 12 V ELECTRIC  
LOCK (REQUIRED FOR GATES  
LONGER THAN 3 m).  
PC/PACK 1



**PLA11**  
HORIZONTAL 12 V ELECTRIC LOCK  
(REQUIRED FOR GATES  
LONGER THAN 3 m).  
PC/PACK 1



**K10**  
KEY-OPERATED SELECTOR  
SWITCH FOR LOW VOLTAGE  
CONTACTS, WITH RELEASE  
MECHANISM FOR METAL  
CORD.  
PC/PACK 1



**KA1**  
6 m CABLE RELEASE KIT  
FOR K10.  
PC/PACK 1



**TS**  
SIGNBOARD.  
PC/PACK 1



● THE SOLAR POWER  
KIT SOLEMYO TO AUTOMATE  
GATES, GARAGE DOORS  
OR BARRIER GATES,  
INCLUDING THOSE LOCATED  
FAR FROM THE POWER MAINS  
AND WITHOUT THE NEED  
FOR COSTLY AND INVASIVE  
EXCAVATION WORK.  
SEE PAGE 171

Nice recommends customers order products in pallets in order to facilitate storage and delivery, and ensure packs are uniform. The number of packs per single pallet has been specified for this reason. Approximate draft.

INSTALLATION DIAGRAM

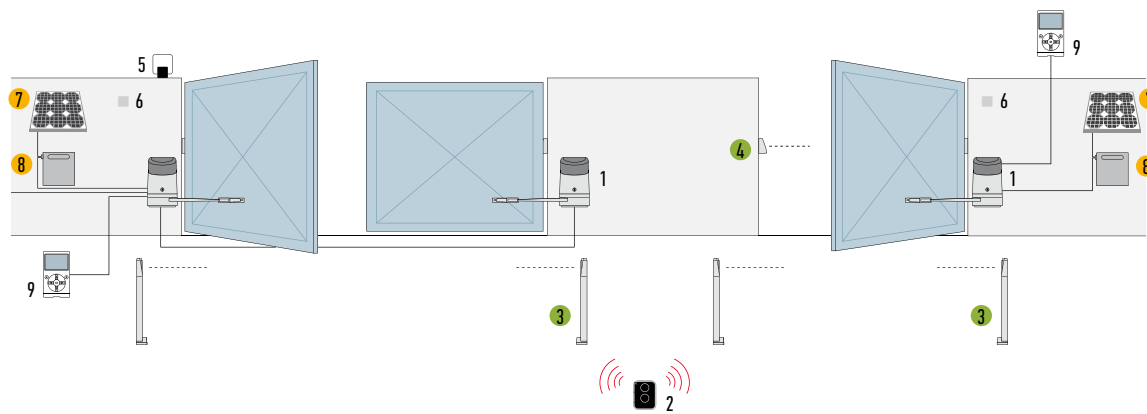

1. MOTOR
2. TRANSMITTER
3. PHOTOCELLS MOUNTED ON POSTS
4. PHOTOCELLS
5. FLASHING LIGHT
6. DIGITAL OR KEY SWITCHES
7. SYP SOLAR PANEL
8. PSY24 BATTERY BOX
9. 0-VIEW MULTIFUNCTION DISPLAY (ONLY FOR PP7124)

- ACCESSORIES ALSO AVAILABLE FOR THE Solemyo Air Net System WIRELESS VERSION
- Solemyo SOLAR POWER ACCESSORIES

# HOPPKIT

SOLEMYO OPERA BLUEBUS 24V

## For swing gates with leaves up to 2.4 m, ideal for large columns.

Irreversible electromechanical 24 Vdc gear motor with articulated arm, surface mounted. Ideal for intensive use.

**Two irreversible** 24 Vdc with micrometric adjustment mechanical stops on opening and closing: with built-in control unit (H07124) and without control unit (H07224).

**Powerful** thanks to the 250 Nm torque.

**Resistant and compact:** 180 mm in width, ideal for any kind of post. Small shockproof body with aluminium base.

**Sturdy, aluminium anti-shearing arm.**

**Easy to install:** thanks to the new fixing bracket with quick connector for the motor. No welding.

**Sophisticated electronics with the built-in control unit,** just 3 keys to manage all programming operations:

- obstacle detection and possibility of connecting to 8.2 KOhm sensitive edge, fototest;
- automatic fault diagnostics;
- memorisation of opening and closing travel limits in self-learning mode;
- possibility of configuring the stop input in self-learning mode, NO, NC and the latest generation 8.2 KOhm resistive sensitive edges;
- deceleration on opening and closing;
- simple connection of pairs of additional photocells, foto2;
- programming of pause time;
- pedestrian open and partial open;
- clutch with anti-crushing safety mechanism.

### Energy saving with no black outs:

3 standby modes to reduce mains consumption, or battery power consumption if connected to the Solemyo kit. Operation in the event of a power failure thanks to the optional batteries (PS124).

**Everything under control: thanks to compatibility for operation with Opera system BUS T4, the unit can be used** to expand the options of programming, control and diagnostics of the automation on site and remotely.

CODE	DESCRIPTION	PACK/PALLET
HOPPKCE	KIT FOR THE AUTOMATION OF SWING GATES WITH LEAVES UP TO 2.4 m, 24 Vdc, EXTERNALLY MOUNTED	12

**N.B.** The content of the package may vary: consult the retailer.

### TECHNICAL SPECIFICATIONS

CODE	H07124	H07224
<b>ELECTRICAL DATA</b>		
POWER SUPPLY (Vac 50/60 Hz)	230	-
POWER SUPPLY (Vdc)	-	24
ABSORPTION (A)	1.3	4
POWER (W)	280	100
<b>PERFORMANCE DATA</b>		
SPEED (rpm)	1.68	
TORQUE (Nm)	250	
WORK CYCLE (CYCLES/HOUR)	35	
<b>DIMENSIONAL AND GENERAL DATA</b>		
PROTECTION LEVEL (IP)	54	
WORKING TEMP. (°C MIN/MAX)	-20 ÷ +50	
DIMENSIONS (mm)	252x180x290 h	
WEIGHT (kg)	9	6.5

\* Version without control unit, only if associated with PP7124

### DIMENSIONS

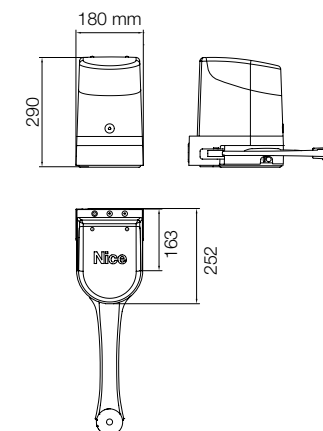

### UTILISATION LIMITS

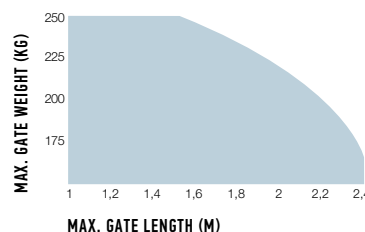

The shape, the height of the gate and the weather conditions can considerably reduce the values shown in the graph to the side.

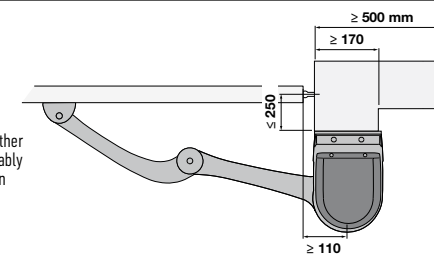

### THE KIT CONTAINS:

**H07124 + H07224**, 2 SURFACE-MOUNTED ELECTROMECHANICAL GEAR MOTORS: H07124 (WITH CONTROL UNIT AND OXI PLUG-IN RECEIVER), H07224 (WITHOUT CONTROL UNIT).



**ON2E**  
1 TRANSMITTER 433.92 MHz,  
2 CHANNELS.



**MOFB**  
1 COUPLE OF EXTERNAL  
PHOTOCELLS DESIGNED  
FOR CONNECTION BY NICE  
BLUEBUS.



**MLBT**  
1 FLASHING LIGHT WITH  
INTEGRATED AERIAL.





**POA3**  
SPARE CONTROL UNIT  
FOR H07174.



**PS124**  
24 V BATTERY  
WITH INTEGRATED  
BATTERY CHARGER.  
PC/PACK 1



**PLA10**  
VERTICAL 12 V ELECTRIC  
LOCK (REQUIRED FOR GATES  
LONGER THAN 3 m).  
PC/PACK 1



**PLA11**  
HORIZONTAL 12 V ELECTRIC LOCK  
(REQUIRED FOR GATES  
LONGER THAN 3 m).  
PC/PACK 1



**K10**  
KEY-OPERATED SELECTOR  
SWITCH FOR LOW VOLTAGE  
CONTACTS, WITH RELEASE  
MECHANISM FOR METAL  
CORD.  
PC/PACK 1



**KA1**  
6 m CABLE RELEASE KIT  
FOR K10.  
PC/PACK 1



**TS**  
SIGNBOARD.  
PC/PACK 1



● THE SOLAR POWER  
KIT SOLEMYO TO AUTOMATE  
GATES, GARAGE DOORS  
OR BARRIER GATES,  
INCLUDING THOSE LOCATED  
FAR FROM THE POWER MAINS  
AND WITHOUT THE NEED  
FOR COSTLY AND INVASIVE  
EXCAVATION WORK.  
SEE PAGE 171

INSTALLATION DIAGRAM

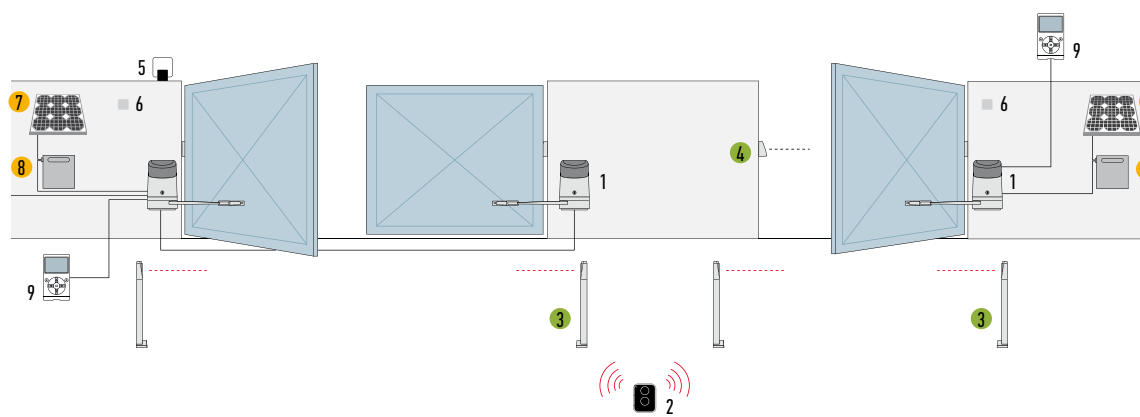

1. MOTOR
2. TRANSMITTER
3. PHOTOCELLS MOUNTED ON POSTS
4. PHOTOCELLS
5. FLASHING LIGHT
6. DIGITAL OR KEY SWITCHES
7. SYP SOLAR PANEL
8. PSY24 BATTERY BOX
9. O-VIEW MULTIFUNCTION DISPLAY (ONLY FOR PP7124)

- ACCESSORIES ALSO AVAILABLE FOR THE Air Net System WIRELESS VERSION
- Solemyo SOLAR POWER ACCESSORIES



Nice recommends customers order products in pallets in order to facilitate storage and delivery, and ensure packs are uniform. The number of packs per single pallet has been specified for this reason. Approximate draft.

## For swing gates with leaves up to 3.5 m, ideal for large columns.

Irreversible electromechanical 24 Vdc gearmotor with articulated arm, surface mounted. Ideal for intensive use.

**Reliable**, durability thanks to the housing in aluminium with polyester paint finish, resistant to atmospheric agents.

**Ultra-powerful and delicate**: thanks to the torque of 500 Nm and encoder technology, for millimetric precision and reliability. Safety in movement with dual technology obstacle detection.

**Two irreversible 24 Vdc versions** with limit switches on opening and closing: with built-in control unit (HK7024) and without control unit (HK7224).

**Practical and quick installation:** the articulated arm is adjustable in length for maximum flexibility.

**Simple and precise limit switch adjustment:** mechanical stops and micrometric adjustment screws.

**Easy to operate release lever**, with metal lock and personalised Nice key. With provision for cable control.

**Savings, respect for the environment, and autonomy:** when connected to the buffer battery or Solemyo kit, consumption on standby is just 0.1 W.

**No black out:** with the optional batteries (PS124) housed inside the gear motor.

### Built-in control unit (HK7024):

- simple programming via a single key;
- self-learning of opening and closing limit positions;
- automatic fault diagnostics;
- pause time programming;
- pass door;
- deceleration on opening and closing;
- obstacle detection with dual technology;
- provision for connection of latest generation sensitive edges.



ADJUSTABLE ANTI-CRUSHING ARM



CODE	DESCRIPTION	PACK/PALLET
HK7024	IRREVERSIBLE 24 Vdc, COMPLETE WITH ARTICULATED ARM AND BUILT-IN CONTROL UNIT	12
HK7224	IRREVERSIBLE 24 Vdc, COMPLETE WITH ARTICULATED ARM WITHOUT CONTROL UNIT	12

### TECHNICAL SPECIFICATIONS

CODE	HK7024	HK7224
<b>ELECTRICAL DATA</b>		
POWER SUPPLY (Vac 50/60 Hz)	230	-
POWER SUPPLY (Vdc)	-	24
ABSORPTION (A)	1.5	6
POWER (W)	300	140
<b>PERFORMANCE DATA</b>		
SPEED (rpm)	2.25	
TORQUE (Nm)	500	
WORK CYCLE (CYCLES/HOUR)	40	
<b>DIMENSIONAL AND GENERAL DATA</b>		
PROTECTION LEVEL (IP)	54	
WORKING TEMP. (°C MIN/MAX)	-20 ÷ +50	
DIMENSIONS (mm)	290x210x320 h	
WEIGHT (kg)	10.5	9.5

### UTILISATION LIMITS

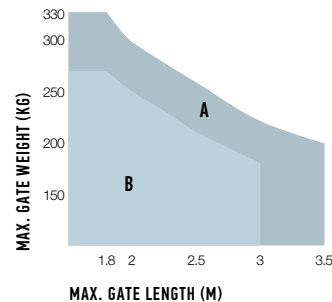
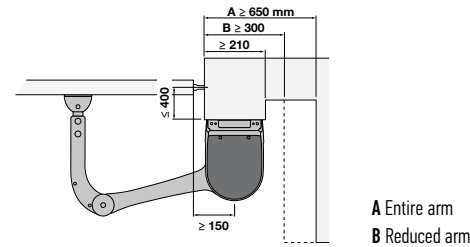

### DIMENSIONS

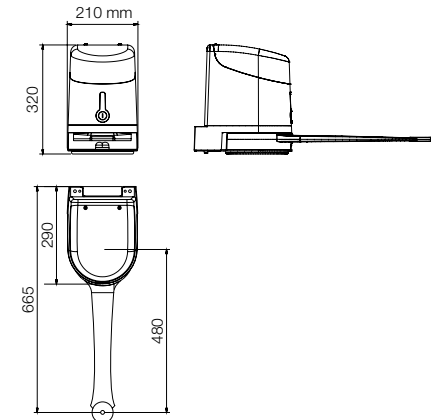

The shape, the height of the gate and the weather conditions can considerably reduce the values shown in the graph to the side.



**HK A1**  
SPARE CONTROL UNIT  
FOR HK7024.



**PS124**  
24 V BATTERY  
WITH INTEGRATED  
BATTERY CHARGER.  
PC/PACK 1



**PLA10**  
VERTICAL 12 V ELECTRIC  
LOCK (REQUIRED FOR GATES  
LONGER THAN 3 m).  
PC/PACK 1



**PLA11**  
HORIZONTAL 12 V ELECTRIC LOCK  
(REQUIRED FOR GATES  
LONGER THAN 3 m).  
PC/PACK 1



**K10**  
KEY-OPERATED SELECTOR  
SWITCH FOR LOW VOLTAGE  
CONTACTS, WITH RELEASE  
MECHANISM FOR METAL  
CORD.  
PC/PACK 1



**KA1**  
6 m CABLE RELEASE KIT  
FOR K10.  
PC/PACK 1



**TS**  
SIGNBOARD.  
PC/PACK 1



● THE SOLAR POWER  
KIT SOLEMYO TO AUTOMATE  
GATES, GARAGE DOORS  
OR BARRIER GATES,  
INCLUDING THOSE LOCATED  
FAR FROM THE POWER MAINS  
AND WITHOUT THE NEED  
FOR COSTLY AND INVASIVE  
EXCAVATION WORK.  
SEE PAGE 171

INSTALLATION DIAGRAM

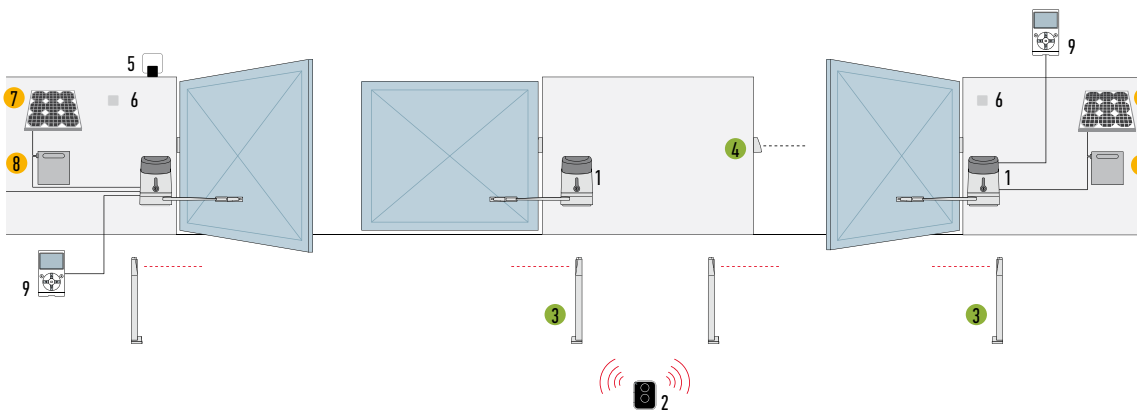

1. MOTOR
2. TRANSMITTER
3. PHOTOCELLS MOUNTED ON POSTS
4. PHOTOCELLS
5. FLASHING LIGHT
6. DIGITAL OR KEY SWITCHES
7. SYP SOLAR PANEL
8. PSY24 BATTERY BOX
9. O-VIEW MULTIFUNCTION DISPLAY

- ACCESSORIES ALSO AVAILABLE FOR THE Solemyo Air Net System WIRELESS VERSION
- Solemyo SOLAR POWER ACCESSORIES

Nice recommends customers order products in pallets in order to facilitate storage and delivery, and ensure packs are uniform. The number of packs per single pallet has been specified for this reason. Approximate draft.

# HYKEKIT

SOLEMYO OPERA BLUEBUS 24V

## For swing gates with leaves up to 3.5 m, ideal for large columns.

Irreversible electromechanical 24 Vdc gear motor with articulated arm, surface mounted. Ideal for intensive use.

**Quality and durability** thanks to the housing in aluminium with polyester paint finish, resistant to atmospheric agents.

**Ultra-powerful and delicate:** thanks to the torque of 500 Nm and encoder technology, for millimetric precision and reliability. Safety in movement with dual technology obstacle detection.



ADJUSTABLE ANTI-CRUSHING ARM

### THE KIT CONTAINS:

#### HK7024 + HK7224

ELECTROMECHANICAL GEAR MOTORS FOR EXTERNAL MOUNTING. HK7024 (WITH CONTROL UNIT AND SNAP-FIT RECEIVER OXI), HK7224 (WITHOUT CONTROL UNIT).



#### ON2E

1 TRANSMITTER 433.92 MHz, 2 CHANNELS.



#### MOFB

1 COUPLE OF EXTERNAL PHOTOCELLS DESIGNED FOR CONNECTION BY NICE BLUEBUS.



#### MLBT

1 FLASHING LIGHT WITH INTEGRATED AERIAL.



**Two irreversible 24 Vdc versions** with limit switches on opening and closing: with built-in control unit (HK7024) and without control unit (HK7224).

#### Practical and quick installation:

the articulated arm is adjustable in length for maximum flexibility.

#### Simple and precise limit switch adjustment:

mechanical stops and micrometric adjustment screws.

#### Easy to operate release lever,

with metal lock and personalised Nice key. With provision for cable control.

#### Savings, respect for the environment, and autonomy:

when connected to the buffer battery or Solemyo kit, consumption on standby is just 0.1 W.

#### No black out:

with the optional batteries (PS124) housed inside the gear motor.

#### Built-in control unit (HK7024):

- simple programming via a single key;
- self-learning of opening and closing limit positions;
- automatic fault diagnostics;
- pause time programming;
- pass door;
- deceleration on opening and closing;
- obstacle detection with dual technology;
- provision for connection of latest generation sensitive edges.

CODE	DESCRIPTION	PACK/PALLET
HYKEKCE	KIT FOR THE AUTOMATION OF SWING GATES WITH LEAVES UP TO 3.5 m, 24 Vdc, WITH ARTICULATED ARM, EXTERNALLY MOUNTED	12

**N.B.** The content of the package may vary; consult the retailer.

### TECHNICAL SPECIFICATIONS

CODE	HK7024	HK7224
<b>ELECTRICAL DATA</b>		
POWER SUPPLY (Vac 50/60 Hz)	230	-
POWER SUPPLY (Vdc)	-	24
ABSORPTION (A)	1.5	6
POWER (W)	300	140
<b>PERFORMANCE DATA</b>		
SPEED (rpm)	2.25	
TORQUE (Nm)	500	
WORK CYCLE (CYCLES/HOUR)	40	
<b>DIMENSIONAL AND GENERAL DATA</b>		
PROTECTION LEVEL (IP)	54	
WORKING TEMP. (°C MIN/MAX)	-20 ÷ +50	
DIMENSIONS (mm)	290x210x320 h	
WEIGHT (kg)	10,5	9,5

### DIMENSIONS

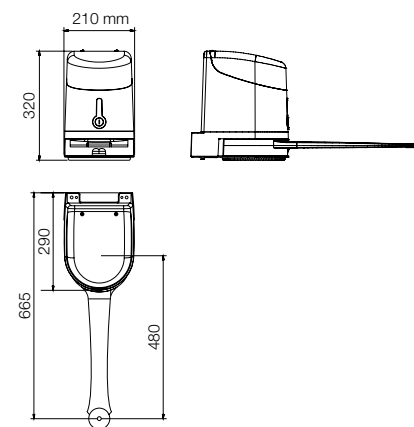

### UTILISATION LIMITS

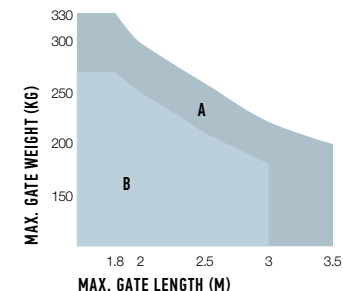
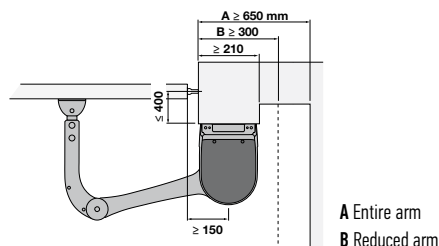

The shape, the height of the gate and the weather conditions can considerably reduce the values shown in the graph to the side.



## ACCESSORIES



**HKA1**  
SPARE CONTROL UNIT  
FOR HK7024.



**PS124**  
24 V BATTERY  
WITH INTEGRATED  
BATTERY CHARGER.  
PC/PACK 1



**PLA10**  
VERTICAL 12 V ELECTRIC  
LOCK (REQUIRED FOR GATES  
LONGER THAN 3 m).  
PC/PACK 1



**PLA11**  
HORIZONTAL 12 V ELECTRIC LOCK  
(REQUIRED FOR GATES  
LONGER THAN 3 m).  
PC/PACK 1



**K10**  
KEY-OPERATED SELECTOR  
SWITCH FOR LOW VOLTAGE  
CONTACTS, WITH RELEASE  
MECHANISM FOR METAL  
CORD.  
PC/PACK 1



**KA1**  
6 m CABLE RELEASE KIT  
FOR K10.  
PC/PACK 1



**TS**  
SIGNBOARD.  
PC/PACK 1



● THE SOLAR POWER  
KIT SOLEMYO TO AUTOMATE  
GATES, GARAGE DOORS  
OR BARRIER GATES,  
INCLUDING THOSE LOCATED  
FAR FROM THE POWER MAINS  
AND WITHOUT THE NEED  
FOR COSTLY AND INVASIVE  
EXCAVATION WORK.  
SEE PAGE 171

## INSTALLATION DIAGRAM

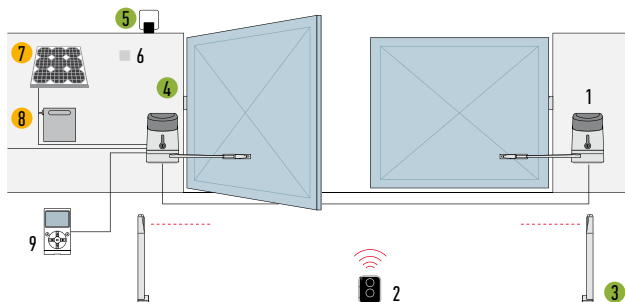

1. MOTOR
2. TRANSMITTER
3. PHOTOCELLS MOUNTED ON POSTS
4. PHOTOCELLS
5. FLASHING LIGHT
6. DIGITAL OR KEY SWITCHES
7. SYP SOLAR PANEL
8. PSY24 BATTERY BOX
9. 0-VIEW MULTIFUNCTION DISPLAY

- ACCESSORIES ALSO AVAILABLE FOR THE Solemyo Air Net System WIRELESS VERSION
- Solemyo SOLAR POWER ACCESSORIES



# HYPPO 7000

SOLEMYO OPERA BLUEBUS 24V 230V

**For swing gates with leaves up to 3 m, also ideal for large pillars.**

Electromechanical gear motor, surface mounted, also in 24 Vdc version with magnetic encoder, with articulated arm.

Single model for right and left leaves.

Two irreversible versions, with 230 Vac (HY7005) and 24 Vdc (HY7024) power supplies with magnetic encoder.

Fewer connections mean **quicker installation.**

**Pre-wired, incorporated double limit-switch** both during opening and closing (HY7005).

**Easy and quick to install:** thanks to fewer connections and nothing welded to the gates.

**Long-lasting:** solid metal mechanics.

**Compact:** shockproof bodywork with no sharp corners.

**Recommended control units:**

Mindy A6F, A60, A700F;  
for HY7024 Moonclever MC824H.

**24 Vdc version** with magnetic encoder.

**Perfect for intensive use,** compatible with the control unit Moonclever MC824H:

- simple programming, by means of a single key;
- self-learning of opening and closing limit positions;
- automatic fault diagnostics;
- programming of pause time;
- pedestrian pass door;
- deceleration on opening and closing;
- obstacle detection with dual technology;
- operation in event of power failure by means of optional rechargeable batteries (PS324);
- provision for connection of latest generation resistive sensitive edges.



CODE	DESCRIPTION	PACK/PALLET
HY7024	IRREVERSIBLE, 24 Vdc, WITH MAGNETIC ENCODER, WITH SHEAR-PROOF ARTICULATED ARM, GALVANIZED AND PAINTED	16
HY7005	IRREVERSIBLE, 230 Vac, WITH STURDY ARTICULATED SHEAR-PROOF ARM, GALVANIZED AND PAINTED, WITH LIMIT SWITCH ON OPENING AND CLOSING	16

**TECHNICAL SPECIFICATIONS**

CODE	HY7024	HY7005
<b>ELECTRICAL DATA</b>		
POWER SUPPLY (Vac 50 Hz)*	-	230
POWER SUPPLY (Vdc)	24	-
ABSORPTION (A)	5	1.2
POWER (W)	120	250
<b>PERFORMANCE DATA</b>		
SPEED (rpm)	2	1.7
TORQUE (Nm)	250	400
WORK CYCLE (%)	80	30
<b>DIMENSIONAL AND GENERAL DATA</b>		
PROTECTION LEVEL (IP)	43	
WORKING TEMP. (°C MIN/MAX)	-20 ÷ +50	
DIMENSIONS (mm)	350x165x242 h	
WEIGHT (kg)	13	

\*60 Hz version available on request.

**UTILISATION LIMITS**

- A Standard arm
- B Arm with accessory HYA12

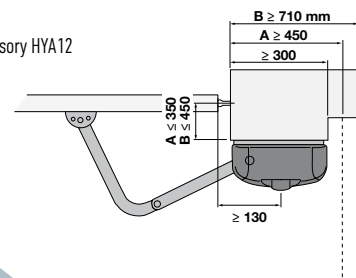

**DIMENSIONS**

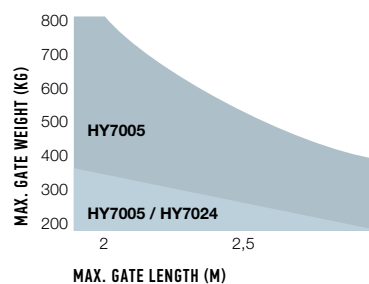
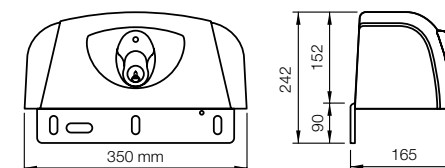

N.B. The above values are valid if the motor is used with standard accessories. The shape, the height of the gate and the weather conditions can considerably reduce the values shown in the graph to the side. Use in windy areas 230 Vac models.

## ACCESSORIES



**HYA12**  
LONGER ARTICULATED ARM  
(SEE THE LAYOUT).

PC/PACK 1



**PLA10**  
VERTICAL 12 V ELECTRIC  
LOCK (REQUIRED FOR GATES  
LONGER THAN 3 m).

PC/PACK 1



**PLA11**  
HORIZONTAL 12 V ELECTRIC LOCK  
(REQUIRED FOR GATES  
LONGER THAN 3 m).

PC/PACK 1



**K10**  
KEY-OPERATED SELECTOR  
SWITCH FOR LOW VOLTAGE  
CONTACTS, WITH RELEASE  
MECHANISM FOR METAL  
CORD.

PC/PACK 1



**KA1**  
6 m CABLE RELEASE KIT  
FOR K10.

PC/PACK 1



**TS**  
SIGNBOARD.

PC/PACK 1



● THE SOLAR POWER  
KIT SOLEMYO TO AUTOMATE  
GATES, GARAGE DOORS  
OR BARRIER GATES,  
INCLUDING THOSE LOCATED  
FAR FROM THE POWER MAINS  
AND WITHOUT THE NEED  
FOR COSTLY AND INVASIVE  
EXCAVATION WORK.  
SEE PAGE 171

## ACCESSORY

For 24 Vdc version



**PS324**  
24 V BATTERY  
WITH INTEGRATED  
BATTERY CHARGER.

PC/PACK 1

## INSTALLATION DIAGRAM

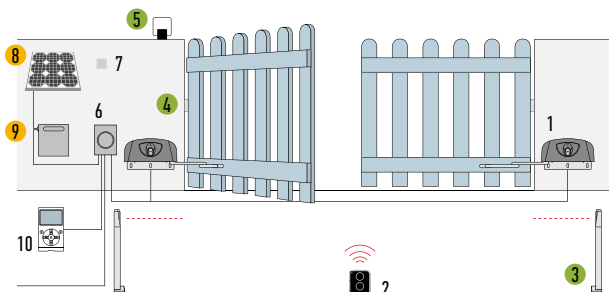

1. MOTOR
2. TRANSMITTER
3. PHOTOCELLS MOUNTED ON POSTS
4. PHOTOCELLS
5. FLASHING LIGHT
6. CONTROL UNIT
7. DIGITAL OR KEY SWITCHES
8. SYP SOLAR PANEL
9. PSY24 BATTERY BOX
10. 0-VIEW MULTIFUNCTION DISPLAY

- ACCESSORIES ALSO AVAILABLE FOR THE Solemyo Air Net System WIRELESS VERSION
- Solemyo SOLAR POWER ACCESSORIES

# X-FAB

SOLEMYO OPERA BLUEBUS 24V

**For swing gates with leaves up to 2.3 m, underground installation, ultra compact.** Irreversible electromechanical 24 Vdc gear motor, ideal for intensive use.

**Sturdy and discreet:** compact foundation box with a height of only 81 mm. Steel with cathaphoresis paint finish guarantees optimal resistance to corrosion, and thickness of 2.5 mm guarantees strength. All this in just 52 mm of protrusion from the ground.

**Practical and quick installation** thanks to the exit lever on the gear motor attached directly on the leaf.

**Opening up to 180° as standard.**

**Reliable and sturdy:** the gear motor, in IP67 pressure die cast aluminium, suspended inside the housing to enable drainage of any deposits, ensures optimal water resistance.

Load-bearing foundation box with adjustable mechanical stops on opening and closing: the gear motor can also be installed later as required.

**Practical release** easy to operate from inside and outside, acting directly on the gear motor, easy to operate by means of the special key.

## XME2024, compatible with the control unit Moonclever MC424L, and for operation with Solemyo systems:

- simple programming via a single key;
- memorisation of opening and closing limit positions in self-learning mode;
- pause time programming;
- pass door;
- deceleration on opening and closing;
- obstacle detection;
- provision for connection of latest generation sensitive edges;
- operation in event of power failure by means of optional rechargeable batteries (PS124) with compartment in control unit.

## XME2124 with magnetic encoder, compatible with control unit Moonclever MC824H, with BlueBUS technology, and compatible for operation with Solemyo and Opera systems:

- simple programming via a single key;
- self-learning of opening and closing limit positions;
- automatic fault diagnostics;
- with output for courtesy light and maintenance indicator;
- speed settings on 5 levels;
- separate and configurable inputs for Step by Step, Open and Close;
- pause time programming;
- pass door;
- deceleration on opening and closing;
- obstacle detection with dual technology;
- provision for connection of latest generation sensitive edges;
- operation in event of power failure by means of optional rechargeable batteries (PS324) with compartment in control unit.

CODE	DESCRIPTION	PACK/PALLET
XME2024	IRREVERSIBLE, 24 Vdc	18
XME2124	IRREVERSIBLE 24 Vdc VERSION WITH MAGNETIC ENCODER	18
XMBOX	EXTERNALLY FOUNDATION BOX, WITH CATAPHORESIS PAINT FINISH. COMPLETE WITH LEAF COUPLING LEVER AND MECHANICAL STOPS ON OPENING AND CLOSING	18

## TECHNICAL SPECIFICATIONS

CODE	XME2024	XME2124
<b>ELECTRICAL DATA</b>		
POWER SUPPLY (Vdc)	24	
ABSORPTION (A)	5	
POWER (W)	120	
<b>PERFORMANCE DATA</b>		
SPEED (rpm)	1.25	
TORQUE (Nm)	250	
WORK CYCLE (CYCLES/HOUR)	60	
<b>DIMENSIONAL AND GENERAL DATA</b>		
PROTECTION LEVEL (IP)	67	
WORKING TEMP. (°C MIN/MAX)	-20° ÷ +50°	
DIMENSIONS (mm)	235x206x96.5 h	
WEIGHT (kg)	6	

WATERPROOF, WITH IP67 PROTECTION RATING



FOUNDATION BOX WITH CATAPHORESIS PAINT FINISH

## UTILISATION LIMITS

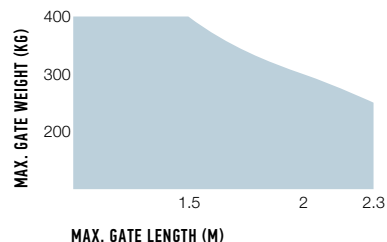

The shape, the height of the gate and the weather conditions can considerably reduce the values shown in the graph to the side.

## DIMENSIONS

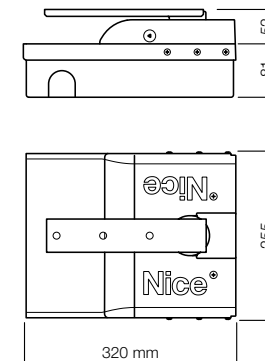

## ACCESSORIES

## KIT SOLEMYO



**PS124**  
24 V BATTERY  
WITH INTEGRATED  
BATTERY CHARGER  
FOR MC424L.  
PC/PACK 1



**PS324**  
24 V BATTERY  
WITH INTEGRATED  
BATTERY CHARGER  
FOR MC824H.  
PC/PACK 1



**PLA10**  
VERTICAL 12 V ELECTRIC  
LOCK.  
PC/PACK 1



**PLA11**  
HORIZONTAL 12 V ELECTRIC  
LOCK.  
PC/PACK 1



**TS**  
SIGNBOARD.  
PC/PACK 1



● THE SOLAR POWER  
KIT SOLEMYO TO AUTOMATE  
GATES, GARAGE DOORS  
OR BARRIER GATES,  
INCLUDING THOSE LOCATED  
FAR FROM THE POWER MAINS  
AND WITHOUT THE NEED  
FOR COSTLY AND INVASIVE  
EXCAVATION WORK.  
SEE PAGE 171

## INSTALLATION DIAGRAM

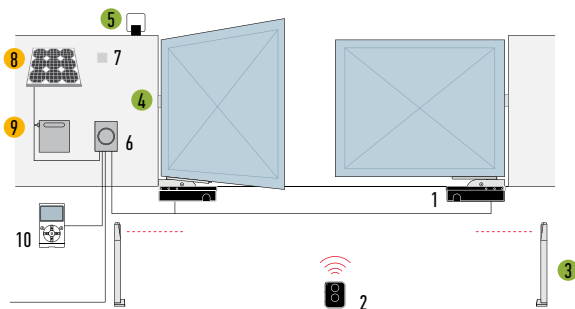

1. MOTOR
2. TRANSMITTER
3. PHOTOCELLS MOUNTED ON POSTS
4. PHOTOCELLS
5. FLASHING LIGHT
6. CONTROL UNIT
7. DIGITAL OR KEY SWITCHES
8. SYP SOLAR PANEL
9. PSY24 BATTERY BOX
10. 0-VIEW MULTIFUNCTION DISPLAY

- ACCESSORIES ALSO AVAILABLE FOR THE Solemyo Air Net System WIRELESS VERSION
- Solemyo SOLAR POWER ACCESSORIES

# X-FABKIT 2024

SOLEMYO 24V

**For swing gates with leaves up to 2.3 m, underground installation, ultra compact.**  
Irreversible electromechanical 24 Vdc gear motor.

**Sturdy and discreet:** compact foundation box with a height of only 81 mm.  
Steel with cataphoresis paint finish guarantees optimal resistance to corrosion, and thickness of 2.5 mm guarantees strength. All this in a protrusion of just 52 mm from the ground.

**Practical and quick installation** thanks to the exit lever on the gear motor attached directly on the leaf.

**Mechanical limit switches** adjustable on opening and closing.

**Opening up to 180° as standard.**

**Reliable and sturdy:** the gear motor, in IP67 pressure die cast aluminium, suspended inside the housing to enable drainage of any deposits, ensures optimal water resistance.

**Practical release** from inside and outside, acting directly on the gear motor, easy to operate by means of the special key.

**Moonclever control unit MC424L:**

- easy programming by pressing a single button;
- clutch with anti-crush safety feature;
- automatic memorization of limit switches on opening and closing with self-learning function;
- programming of pause time;
- pedestrian pass door;
- deceleration on opening and closing;
- obstacle detection;
- provision for connection of latest generation resistive sensitive edges;
- continues to work even during power failures using optional (PS124) batteries that fit inside the control unit.

CODE	DESCRIPTION	PACK/PALLET
XMETR02024KCE	KIT FOR SWING GATES WITH LEAVES UP TO 2.3 m, 24 Vdc, UNDERGROUND INSTALLATION	12

**N.B.** The content of the package may vary; consult the retailer.

## TECHNICAL SPECIFICATIONS

CODE	XME2024
<b>ELECTRICAL DATA</b>	
POWER SUPPLY (Vdc)	24
ABSORPTION (A)	5
POWER (W)	120
<b>PERFORMANCE DATA</b>	
SPEED (rpm)	1.25
TORQUE (Nm)	250
WORK CYCLE (CYCLES/HOUR)	60
<b>DIMENSIONAL AND GENERAL DATA</b>	
PROTECTION LEVEL (IP)	67
WORKING TEMP. (°C MIN/MAX)	-20° ÷ +50°
DIMENSIONS (mm)	235x206x96.5 h
WEIGHT (kg)	6

## DIMENSIONS

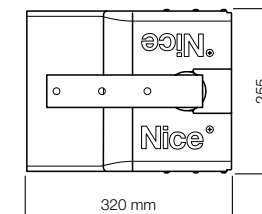
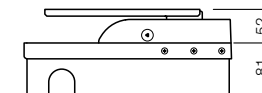

## UTILISATION LIMITS

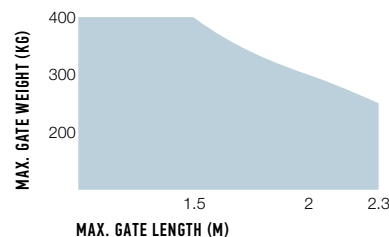

The shape, the height of the gate and the weather conditions can considerably reduce the values shown in the graph to the side.

## THE KIT CONTAINS:

**XME2024**  
2 GEAR MOTORS.  
**XMBOX**  
2 FOUNDATION BOXES.



**ON2E**  
1 TRANSMITTER 433.92 MHz,  
2 CHANNELS.



**MC424L**  
1 CONTROL UNIT WITH OXI  
PLUG-IN RECEIVER.



**MOF**  
1 PAIR OF PHOTOCELLS  
FOR OUTDOOR INSTALLATION.



**MOSE**  
1 KEY SELECTOR SWITCH  
FOR OUTDOOR INSTALLATION.



**ML24T**  
1 FLASHING LIGHT  
WITH INTEGRATED AERIAL.



**TS**  
1 SIGNBOARD.



## ACCESSORIES



**PS124**  
24 V BATTERY  
WITH INTEGRATED  
BATTERY CHARGER.  
PC/PACK 1



**PLA10**  
VERTICAL 12 V ELECTRIC  
LOCK.  
PC/PACK 1



**PLA11**  
HORIZONTAL 12 V ELECTRIC  
LOCK.  
PC/PACK 1

## KIT SOLEMYO



- THE SOLAR POWER KIT SOLEMYO TO AUTOMATE GATES, GARAGE DOORS OR BARRIER GATES, INCLUDING THOSE LOCATED FAR FROM THE POWER MAINS AND WITHOUT THE NEED FOR COSTLY AND INVASIVE EXCAVATION WORK. SEE PAGE 171

## INSTALLATION DIAGRAM

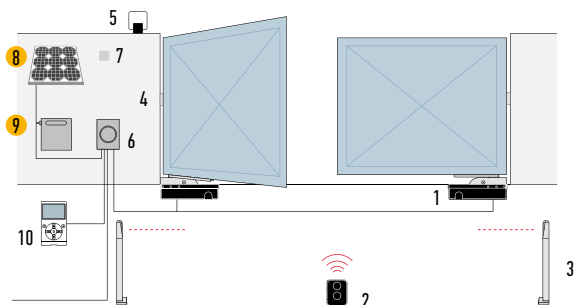

1. MOTOR
2. TRANSMITTER
3. PHOTOCELLS MOUNTED ON POSTS
4. PHOTOCELLS
5. FLASHING LIGHT
6. CONTROL UNIT
7. DIGITAL OR KEY SWITCHES
8. SYP SOLAR PANEL
9. PSY24 BATTERY BOX
10. 0-VIEW MULTIFUNCTION DISPLAY

● Solemyo SOLAR POWER ACCESSORIES



# X-FABKIT 2124

SOLEMYO OPERA BLUEBUS 24V

**For swing gates with leaves up to 2.3 m, underground installation, ultra compact.**

Irreversible electromechanical gear motor 24 Vdc with magnetic encoder.

**Sturdy and discreet:** compact foundation box with a height of only 81 mm.

Steel with cathodolysis paint finish guarantees optimal resistance to corrosion, and thickness of 2.5 mm guarantees strength. All this in a protrusion of just 52 mm from the ground.

**Practical and quick installation**

thanks to the exit lever on the gear motor attached directly on the leaf.

**Mechanical limit switches** adjustable on opening and closing.

**Opening up to 180° as standard.**

**Reliable and sturdy:** the gear motor, in IP67 pressure die cast aluminium, suspended inside the housing to enable drainage of any deposits, ensures optimal water resistance.

**Practical release** from inside and outside, acting directly on the gear motor, easy to operate by means of the special key.

**Control unit Moonclever MC824H, with BlueBUS technology, and compatible for operation with Solemyo and Opera systems:**

- simple programming, by means of a single key;
- self-learning of opening and closing limit positions;
- automatic fault diagnostics;
- programming of pause time;
- pedestrian pass door;
- deceleration on opening and closing;
- obstacle detection with dual technology;
- operation in event of power failure by means of optional rechargeable batteries (PS324);
- provision for connection of latest generation resistive sensitive edges.

CODE	DESCRIPTION	PACK/PALLET
XMETRO2124KCE	KIT FOR SWING GATES WITH LEAVES UP TO 2.3 m, 24 Vdc, UNDERGROUND INSTALLATION	12

**N.B.** The content of the package may vary; consult the retailer.

## TECHNICAL SPECIFICATIONS

CODE	XME2124
<b>ELECTRICAL DATA</b>	
POWER SUPPLY (Vdc)	24
ABSORPTION (A)	5
POWER (W)	120
<b>PERFORMANCE DATA</b>	
SPEED (rpm)	1.25
TORQUE (Nm)	250
WORK CYCLE (CYCLES/HOUR)	60
<b>DIMENSIONAL AND GENERAL DATA</b>	
PROTECTION LEVEL (IP)	67
WORKING TEMP. (°C MIN/MAX)	-20° ÷ +50°
DIMENSIONS (mm)	235x206x96.5 h
WEIGHT (kg)	6

## DIMENSIONS

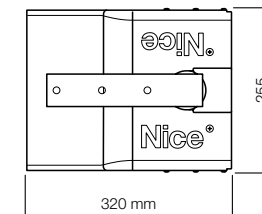
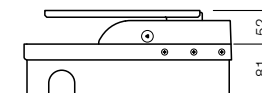

## UTILISATION LIMITS

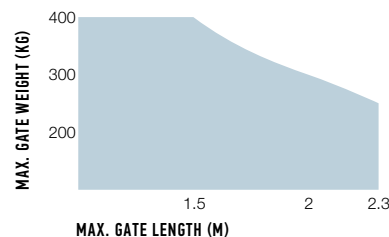

The shape, the height of the gate and the weather conditions can considerably reduce the values shown in the graph to the side.

## THE KIT CONTAINS:

**XME2124**  
2 GEAR MOTORS.  
**XMBOX**  
2 FOUNDATION BOXES.



**ON2E**  
1 TRANSMITTER 433.92 MHz,  
2 CHANNELS.



**MC824H**  
1 CONTROL UNIT WITH OXI  
PLUG-IN RECEIVER.



**MOFB**  
1 COUPLE OF EXTERNAL  
PHOTOCELLS DESIGNED  
FOR CONNECTION BY NICE  
BLUEBUS.



**MOSE**  
1 KEY SELECTOR SWITCH  
FOR OUTDOOR INSTALLATION.



**MLBT**  
1 FLASHING LIGHT WITH  
INTEGRATED AERIAL.



**TS**  
1 SIGNBOARD.





**ACCESSORIES**



**PS324**  
24 V BATTERY  
WITH INTEGRATED  
BATTERY CHARGER.  
PC/PACK 1



**PLA10**  
VERTICAL 12 V ELECTRIC  
LOCK.  
PC/PACK 1



**PLA11**  
HORIZONTAL 12 V ELECTRIC  
LOCK.  
PC/PACK 1

**KIT SOLEMYO**



● THE SOLAR POWER KIT SOLEMYO TO AUTOMATE GATES, GARAGE DOORS OR BARRIER GATES, INCLUDING THOSE LOCATED FAR FROM THE POWER MAINS AND WITHOUT THE NEED FOR COSTLY AND INVASIVE EXCAVATION WORK. SEE PAGE 171

Nice recommends customers order products in pallets in order to facilitate storage and delivery, and ensure packs are uniform. The number of packs per single pallet has been specified for this reason. Approximate draft.

**INSTALLATION DIAGRAM**

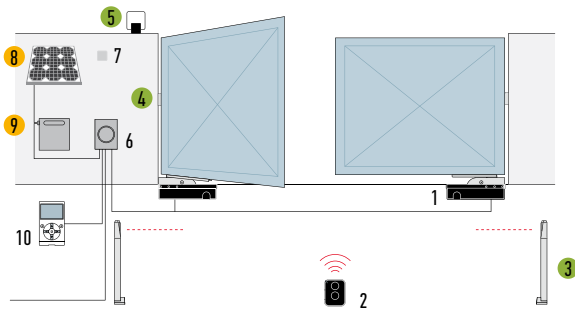

1. MOTOR
2. TRANSMITTER
3. PHOTOCELLS MOUNTED ON POSTS
4. PHOTOCELLS
5. FLASHING LIGHT
6. CONTROL UNIT
7. DIGITAL OR KEY SWITCHES
8. SYP SOLAR PANEL
9. PSY24 BATTERY BOX
10. 0-VIEW MULTIFUNCTION DISPLAY

- ACCESSORIES ALSO AVAILABLE FOR THE Solemyo Air Net System WIRELESS VERSION
- Solemyo SOLAR POWER ACCESSORIES



# M-FAB

SOLEMYO OPERA BLUEBUS 24V 230V

## For swing gates with leaves up to 3 m, underground installation.

Irreversible electromechanical gear motor, also available in 24 Vdc versions with magnetic encoder.

**An even more evolved range:** 3 types of electromechanical gear motors irreversible **M-Fab**.

**2 foundation boxes externally chamfered, Fab Box,** with mechanical stop on opening:

- in stainless steel (MECX), ideal for use in extreme conditions;
- with the **cataphoresis paint finish** (MECF), highly resistant to corrosion.

**Reliable and resistant:** motors made up of solid internal parts in metal. New IP67 waterproof die cast aluminium.

**Total freedom of choice:** release from inside and outside, two key-operated models or freely compatible lever version and easily activated with just one hand.

**Simple to use:** mechanical stop system on closure. Standard opening max. 110°, optional opening 360°.

**Totally compatible** with the previous Metro series.

**Recommended control units:** Mindy A6F, A60, A700F; for ME3024 Moonclever MC824H.

**24 Vdc version** with magnetic encoder.

**Perfect for intensive use,** compatible with the control unit Moonclever MC824H:

- simple programming, by means of a single key;
- self-learning of opening and closing limit positions;
- automatic fault diagnostics;
- programming of pause time;
- pedestrian pass door;
- deceleration on opening and closing;
- obstacle detection with dual technology;
- operation in event of power failure by means of optional rechargeable batteries (PS324);
- provision for connection of latest generation resistive sensitive edges.

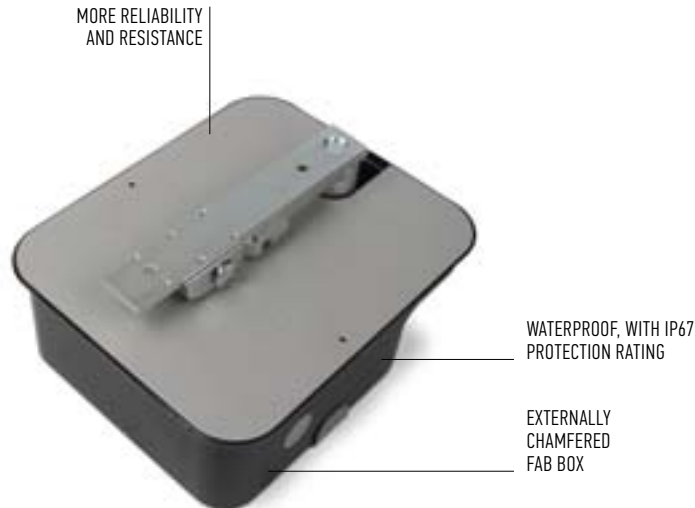

CODE	DESCRIPTION	PACK/PALLET
<b>ME3024</b>	IRREVERSIBLE, 24 Vdc, WITH MAGNETIC ENCODER, COMPLETE WITH CONNECTING LEVER AND MECHANICAL STOP FOR THE CLOSING MANOEUVRE	18
<b>ME3000</b>	IRREVERSIBLE, 230 Vac, HIGH SPEED, GREASE LUBRICATION, COMPLETE WITH CONNECTING LEVER AND MECHANICAL STOP FOR THE CLOSING MANOEUVRE	18
<b>ME3000L</b>	IRREVERSIBLE, 230 Vac, LOW SPEED, GREASE LUBRICATION, COMPLETE WITH CONNECTING LEVER AND MECHANICAL STOP FOR THE CLOSING MANOEUVRE	18

CODE	DESCRIPTION	PACK/PALLET
<b>MECX</b>	EXTERNALLY CHAMFERED FOUNDATION BOX IN STAINLESS STEEL WITH MECHANICAL STOP ON OPENING	20
<b>MECF</b>	EXTERNALLY CHAMFERED FOUNDATION BOX WITH CATAPHORESIS FINISH WITH MECHANICAL STOP ON OPENING	20

**NOTE:** key release mechanism, freely compatible with selection of models MEA2 and MEA3 motor.

## TECHNICAL SPECIFICATIONS

CODE	ME3024	ME3000	ME3000L
<b>ELECTRICAL DATA</b>			
POWER SUPPLY (Vac 50 Hz)*	-	230	-
POWER SUPPLY (Vdc)	24	-	-
ABSORPTION (A)	5	1.2	1.3
POWER (W)	120	250	300
<b>PERFORMANCE DATA</b>			
SPEED (rpm)	1.4	1.14	0.8
TORQUE (Nm)	250	300	250
WORK CYCLE (CYCLES/HOUR)	76	30	20
<b>DIMENSIONAL AND GENERAL DATA</b>			
PROTECTION LEVEL (IP)	67		
WORKING TEMP. (°C MIN/MAX)	-20 ÷ +50		
DIMENSIONS (mm)	390x322x194.5 h		
WEIGHT (kg)	11		

\*60 Hz version available on request.

## UTILISATION LIMITS

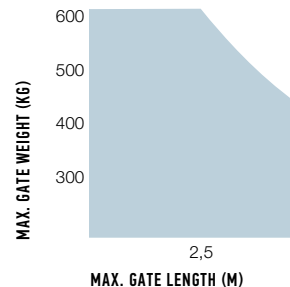

The shape, the height of the gate and the weather conditions can considerably reduce the values shown in the graph to the side. Use in windy areas 230 Vac models.

## DIMENSIONS

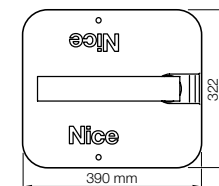
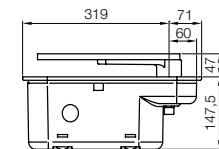

## ACCESSORIES

## KIT SOLEMYO



**ME A2**  
KEY UNLOCK SYSTEM.  
PC/PACK 1



**ME A3**  
LEVER-TYPE KEY UNLOCK  
SYSTEM TO USE WHEN  
SYSTEM IS INSTALLED  
ON SURFACES SUCH  
AS SAND OR EARTH.  
PC/PACK 1



**ME A5**  
LEVER-TYPE UNLOCK KEY  
FOR ME A3.  
PC/PACK 4



**ME A6**  
LIMIT SWITCH BRACKET,  
FOR INSTALLATIONS  
WHERE BOX EMBEDDING IN  
CONCRETE IS NOT POSSIBLE.  
PC/PACK 1



**ME A1**  
ACCESSORY FOR OPENING  
UP TO 360° FOR GATES  
MAX. 2.5 m IN LENGTH.  
PC/PACK 1



**PL A10**  
VERTICAL 12 V ELECTRIC  
LOCK.  
PC/PACK 1



**PL A11**  
HORIZONTAL 12 V ELECTRIC  
LOCK.  
PC/PACK 1



**TS**  
SIGNBOARD.  
PC/PACK 1



● THE SOLAR POWER  
KIT SOLEMYO TO AUTOMATE  
GATES, GARAGE DOORS  
OR BARRIER GATES,  
INCLUDING THOSE LOCATED  
FAR FROM THE POWER MAINS  
AND WITHOUT THE NEED  
FOR COSTLY AND INVASIVE  
EXCAVATION WORK.  
SEE PAGE 171

## ACCESSORY

For 24 Vdc version



**PS324**  
24 V BATTERY  
WITH INTEGRATED  
BATTERY CHARGER.  
PC/PACK 1

## INSTALLATION DIAGRAM

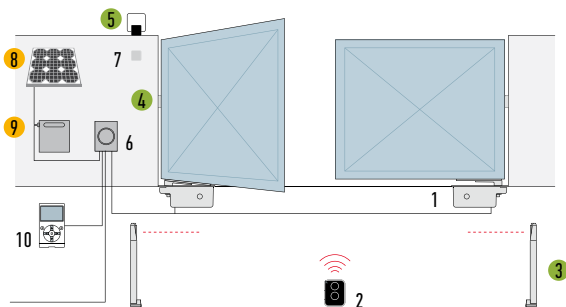

1. MOTOR
2. TRANSMITTER
3. PHOTOCELLS MOUNTED ON POSTS
4. PHOTOCELLS
5. FLASHING LIGHT
6. CONTROL UNIT
7. DIGITAL OR KEY SWITCHES
8. SYP SOLAR PANEL
9. PSY24 BATTERY BOX
10. 0-VIEW MULTIFUNCTION DISPLAY

- ACCESSORIES ALSO AVAILABLE FOR THE Solemyo Air Net System WIRELESS VERSION
- Solemyo SOLAR POWER ACCESSORIES

Nice recommends customers order products in pallets in order to facilitate storage and delivery, and ensure packs are uniform. The number of packs per single pallet has been specified for this reason. Approximate draft.

# L-FAB

NEW SOLEMYO OPERA BLUEBUS 24V 230V

## For swing gates with leaves up to 4 m, underground installation.

Irreversible electromechanical gear motor, also available in 24 Vdc versions with magnetic encoder and mechanical stop.

Foundation boxes with mechanical stop on opening:

- in stainless steel (BMBOX4I), ideal for use in extreme conditions,
- with cataphoresis paint finish (BMBOX4), highly resistant to corrosion.

**Maximum freedom of choice:** release from inside or outside, two key or lever operated models, freely combinable and easy to operate with just one hand.

**Simple installation:** built-in mechanical stop system on closure.

Standard opening to 110°, or optional 360°.

**Ideal for intensive use, BM4024 model is compatible with the control unit Moonclever MC824H, with BlueBUS technology, Solemyo and Opera systems:**

- simple programming via a single key;
- self-learning of travel limits on opening and closing;
- self-diagnostics of faults;
- programming of pause time;
- pass door;
- deceleration on opening and closing;
- dual technology obstacle detection;
- operation in the event of a power failure with optional rechargeable batteries (PS324);
- provision for connection of latest generation sensitive edges.

BM4000 model is compatible with the control units A6F and A60.



### ACCESSORY FOR L-FAB

**BMA2**  
ADAPTORS FOR A DUAL MOTOR AUTOMATION, COMPATIBLE WITH THE MAJORITY OF FOUNDATION BOXES ON THE MARKET.

PC/PACK. 4



### WITH LEAVES UP TO 4 M

CODE	DESCRIPTION	PACK/PALLET
BM4000	IRREVERSIBLE 230 Vac WITH BUILT-IN MECHANICAL STOP ON CLOSING	18
BM4024	IRREVERSIBLE 24 Vdc, WITH MAGNETIC ENCODER, WITH MECHANICAL STOP ON CLOSING	18
BMBOX4	FOUNDATION BOX WITH CATAPHORESIS PAINT FINISH FOR BM4000 AND BM4024 WITH BUILT-IN MECHANICAL STOP ON OPENING. COMPLETE WITH LEAF COUPLING LEVER	18
BMBOX4I	STAINLESS STEEL FOUNDATION BOX FOR BM4000 AND BM4024 WITH BUILT-IN MECHANICAL STOP ON OPENING. COMPLETE WITH LEAF COUPLING LEVER	18

Note: key release mechanism, freely compatible with selection of models MEA2 and MEA3 motor.

### TECHNICAL SPECIFICATIONS

CODE	BM4024	BM4000
<b>ELECTRICAL DATA</b>		
POWER SUPPLY (Vac 50 Hz)*	-	230
POWER SUPPLY (Vdc)	24	-
ABSORPTION (A)	5	1.5
POWER (W)	120	340
<b>PERFORMANCE DATA</b>		
SPEED (rpm)	1	0.8
TORQUE (Nm)	300	500
WORK CYCLE (%)	60	20

### DIMENSIONAL AND GENERAL DATA

PROTECTION LEVEL (IP)	67	
WORKING TEMP. (°C MIN/MAX)	-20 ÷ +50	
DIMENSIONS (mm)	400x325x150 h	
WEIGHT (kg)	12.5	14.3

\*60 Hz version available on request.

FOUNDATION BOX	BMBOX4
WEIGHT (kg)	14.4

### UTILISATION LIMITS

#### BM4000 - BM4024

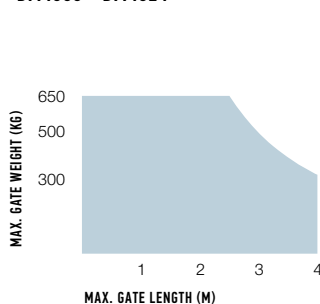

The shape, the height of the gate and the weather conditions can considerably reduce the values shown in the graph to the side. Use in windy areas 230 Vac models.

### DIMENSIONS

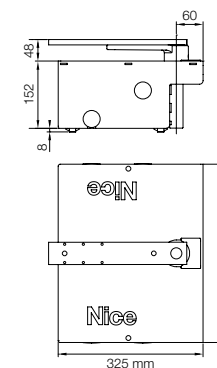

## ACCESSORIES

## KIT SOLEMYO



**ME A2**  
KEY UNLOCK SYSTEM.  
PC/PACK 1



**ME A3**  
LEVER-TYPE KEY UNLOCK SYSTEM TO USE WHEN SYSTEM IS INSTALLED ON SURFACES SUCH AS SAND OR EARTH.  
PC/PACK 1



**ME A5**  
LEVER-TYPE UNLOCK KEY FOR ME A3.  
PC/PACK 4



**BMA1**  
ACCESSORY FOR OPENING UP TO 360° FOR GATES MAX. 3.5 m IN LENGTH.  
PC/PACK 1



**PLA10**  
VERTICAL 12 V ELECTRIC LOCK (REQUIRED FOR GATES LONGER THAN 3 m).  
PC/PACK 1



**PLA11**  
HORIZONTAL 12 V ELECTRIC LOCK (REQUIRED FOR GATES LONGER THAN 3 m).  
PC/PACK 1



**TS**  
SIGNBOARD.  
PC/PACK 1



● THE SOLAR POWER KIT SOLEMYO TO AUTOMATE GATES, GARAGE DOORS OR BARRIER GATES, INCLUDING THOSE LOCATED FAR FROM THE POWER MAINS AND WITHOUT THE NEED FOR COSTLY AND INVASIVE EXCAVATION WORK. SEE PAGE 171

## ACCESSORY

For 24 Vdc version



**PS324**  
24 V BATTERY WITH INTEGRATED BATTERY CHARGER.  
PC/PACK 1

## INSTALLATION DIAGRAM

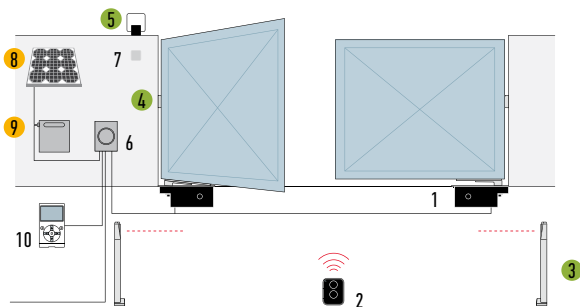

1. MOTOR
2. TRANSMITTER
3. PHOTOCELLS MOUNTED ON POSTS
4. PHOTOCELLS
5. FLASHING LIGHT
6. CONTROL UNIT
7. DIGITAL OR KEY SWITCHES
8. SYP SOLAR PANEL
9. PSY24 BATTERY BOX
10. 0-VIEW MULTIFUNCTION DISPLAY

FOR BM4024 MODEL:

- ACCESSORIES ALSO AVAILABLE FOR THE Solemyo Air Net System WIRELESS VERSION
- Solemyo SOLAR POWER ACCESSORIES

Nice recommends customers order products in pallets in order to facilitate storage and delivery, and ensure packs are uniform. The number of packs per single pallet has been specified for this reason. Approximate draft.

# BIG-FAB

SOLEMYO OPERA BLUEBUS 24V

## For swing gates with leaves up to 5 m, underground installation.

Irreversible electromechanical gear motor, 24 Vdc with magnetic encoder and mechanical stop.

**Chamfered foundation boxes** with mechanical stop on opening:

- in stainless steel (BMBOXI), ideal for use in extreme conditions,
- with cataphoresis paint finish (BMBOX), highly resistant to corrosion.

**Maximum freedom of choice:** release from inside or outside, two key or lever operated models, freely combinable and easy to operate with just one hand.

**Simple to use:** mechanical stop system on closure. Standard opening to 110°, or optional 360°.

**Ideal for intensive use, compatible with the control unit Moonclever MC824H:**

- simple programming via a single key;
- self-learning of travel limits on opening and closing;
- self-diagnostics of faults;
- programming of pause time;
- pass door;
- deceleration on opening and closing;
- dual technology obstacle detection;
- operation in the event of a power failure with optional rechargeable batteries (PS324);
- provision for connection of latest generation sensitive edges.



### ACCESSORY FOR L-FAB

**BMA2**  
ADAPTORS FOR A DUAL MOTOR AUTOMATION, COMPATIBLE WITH THE MAJORITY OF FOUNDATION BOXES ON THE MARKET.

PC/PACK. 4



CODE	DESCRIPTION	PACK/PALLET
<b>BM5024</b>	IRREVERSIBLE, 24 Vdc, WITH MAGNETIC ENCODER, WITH MECHANICAL STOP ON CLOSING	18
<b>BMBOX</b>	FOUNDATION BOX, WITH CATAPHORESIS PAINT FINISH, WITH BUILT-IN MECHANICAL STOP ON OPENING	18
<b>BMBOXI</b>	STAINLESS STEEL FOUNDATION BOX, WITH BUILT-IN MECHANICAL STOP ON OPENING	18

**NOTE:** key release mechanism, freely compatible with selection of models MEA2 and MEA3 motor.

### TECHNICAL SPECIFICATIONS

CODE	BM5024
<b>ELECTRICAL DATA</b>	
POWER SUPPLY (Vdc)	24
ABSORPTION (A)	7
POWER (W)	170
<b>PERFORMANCE DATA</b>	
SPEED (rpm)	0.8
TORQUE (Nm)	400
WORK CYCLE (CYCLES/HOUR)	45
<b>DIMENSIONAL AND GENERAL DATA</b>	
PROTECTION LEVEL (IP)	67
WORKING TEMP. (°C MIN/MAX)	-20 ÷ +50
DIMENSIONS (mm)*	400x325x150 h
WEIGHT (kg)	13.3

\*With foundation box

FOUNDATION BOX	BMBOX
WEIGHT (kg)	20.3

### UTILISATION LIMITS

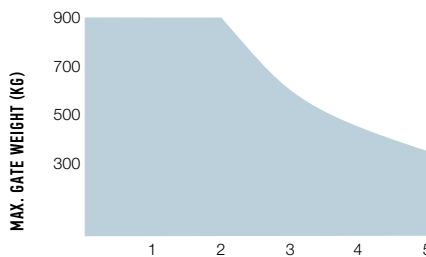

The shape, the height of the gate and the weather conditions can considerably reduce the values shown in the graph to the side. Use in windy areas 230 Vac models.

### DIMENSIONS

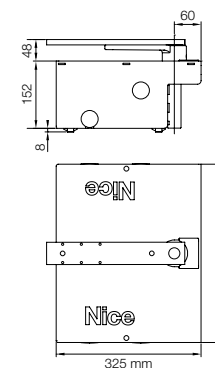

## ACCESSORIES

## KIT SOLEMYO



**ME A2**  
KEY UNLOCK SYSTEM.  
PC/PACK 1



**ME A3**  
LEVER-TYPE KEY UNLOCK SYSTEM TO USE WHEN SYSTEM IS INSTALLED ON SURFACES SUCH AS SAND OR EARTH.  
PC/PACK 1



**ME A5**  
LEVER-TYPE UNLOCK KEY FOR ME A3.  
PC/PACK 4



**BMA1**  
ACCESSORY FOR OPENING UP TO 360° FOR GATES MAX. 3.5 m IN LENGTH.  
PC/PACK 1



**PLA10**  
VERTICAL 12 V ELECTRIC LOCK (REQUIRED FOR GATES LONGER THAN 3 m).  
PC/PACK 1



**PLA11**  
HORIZONTAL 12 V ELECTRIC LOCK (REQUIRED FOR GATES LONGER THAN 3 m).  
PC/PACK 1



**TS**  
SIGNBOARD.  
PC/PACK 1



● THE SOLAR POWER KIT SOLEMYO TO AUTOMATE GATES, GARAGE DOORS OR BARRIER GATES, INCLUDING THOSE LOCATED FAR FROM THE POWER MAINS AND WITHOUT THE NEED FOR COSTLY AND INVASIVE EXCAVATION WORK. SEE PAGE 171

## ACCESSORY

For 24 Vdc version



**PS324**  
24 V BATTERY WITH INTEGRATED BATTERY CHARGER.  
PC/PACK 1

## INSTALLATION DIAGRAM

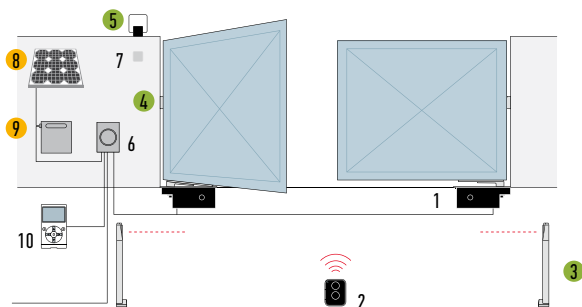

1. MOTOR
2. TRANSMITTER
3. PHOTOCELLS MOUNTED ON POSTS
4. PHOTOCELLS
5. FLASHING LIGHT
6. CONTROL UNIT
7. DIGITAL OR KEY SWITCHES
8. SYP SOLAR PANEL
9. PSY24 BATTERY BOX
10. 0-VIEW MULTIFUNCTION DISPLAY

- ACCESSORIES ALSO AVAILABLE FOR THE Solemyo Air Net System WIRELESS VERSION
- Solemyo SOLAR POWER ACCESSORIES

Nice recommends customers order products in pallets in order to facilitate storage and delivery, and ensure packs are uniform. The number of packs per single pallet has been specified for this reason. Approximate draft.





# SYSTEMS FOR SLIDING GATES



FOR RESIDENTIAL USE,  
INSTALLED INSIDE A COMPACT POST

76

NAKED SLIDING 400

---

FOR RESIDENTIAL AND INDUSTRIAL USE

78

ROBUS 400/600/1000

80

ROBUSKIT 400

82

ROBUSKIT 600

84

ROADKIT

86

RUN 1500

88

RUN 1800/2500

90

TUB

---

RACKS

91

# SELECTION GUIDE

## FOR RESIDENTIAL USE, INSTALLED INSIDE A COMPACT POST

Irreversible, 24 Vdc, with built-in control unit and absolute encoder.  
With BlueBUS technology, compatible for operation with Solemyo and Opera.

**NAKED SLIDING 400**  
pages 76/77

for gates up to 400 kg

**NKSL400**

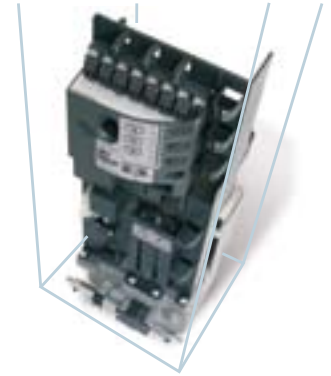

## FOR RESIDENTIAL USE, ALSO AVAILABLE IN KIT

Irreversible, 24 Vdc, with built-in control unit.  
With BlueBUS technology, compatible for operation with Solemyo and Opera.

**ROBUS  
ROBUSKIT**  
pages 78/83

for gates up to 400 kg  
with electromechanical limit switch

Kit

**RB400**

**RB400KCE**

for gates up to 600 kg

electromechanical limit switch

Kit

**RB600**

**RB600KCE**

inductive limit switch

**RB600P**

for gates up to 1000 kg

electromechanical limit switch

**RB1000**

inductive limit switch

**RB1000P**



Irreversible, 24 Vdc, with built-in control unit.  
For gates up to 400 kg with leaf length up to 6 m

**ROADKIT**  
pages 84/85

**RDKCE**



**FOR RESIDENTIAL AND INDUSTRIAL USE**

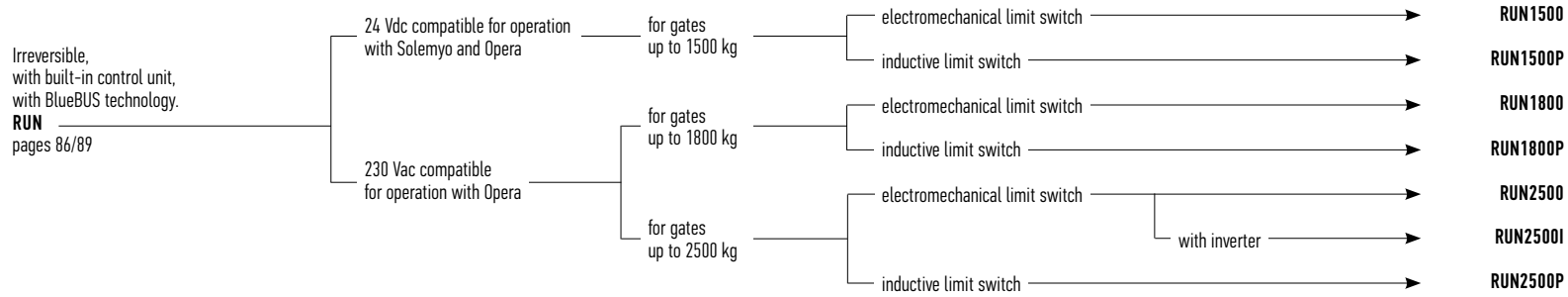

**FOR INDUSTRIAL USE**

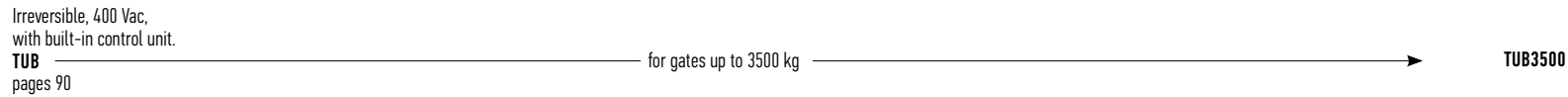

# NAKED SLIDING 400

SOLEMYO OPERA BLUEBUS 24V

## Nice concealed motor for sliding gates up to 400 Kg with leaf length up to 6 m.

Motor with built-in control unit and absolute encoder which can be installed inside a compact post with suitable holes.

Its extremely small size allows the motor to be installed even in very slender posts, with interior size down to 140x140 mm.

**User-friendly:** thanks to the BlueBUS system, allowing the control unit to be connected to up to 7 pairs of Moonbus series photocells and control, security and signalling devices with just two wires.

**State-of-the-art:** it features a temperature sensor that adapts the motor force to weather conditions, also modulating the overload protection.

**Master/slave selection:** for automatic synchronisation even of 2 motors, allowing automation of sliding gates with two opposing leaves.

**Intelligent:** thanks to obstacle detection and automatic working time programming. Self-diagnostics with flashing light signalling.

**Safe:** adjustable acceleration and deceleration at the start and end of every opening and closing operation.

**User-friendly, precise limit switch adjustment:** integral absolute limit switch, quick learning with just one opening or closing operation with motor released.

**Practical:** control unit and optional PS124 buffer batteries can be connected by means of practical guided - connector.

**Flexible:** unlocking can be provided on both sides of the post and/or on the outside (with the K10 and KA1 accessories). Also easy to install on existing posts.

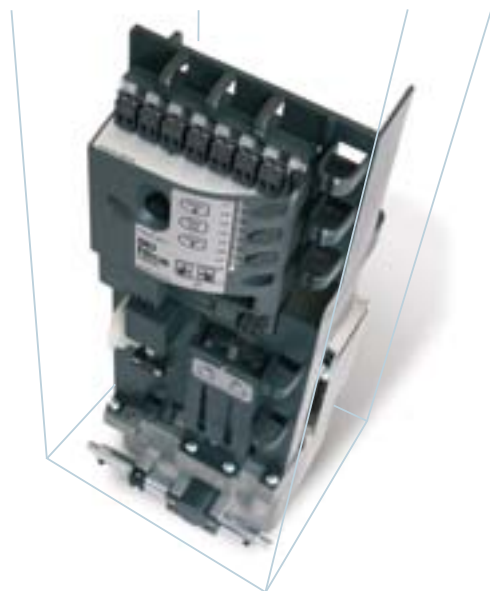

CODE	DESCRIPTION	PACK/PALLET
NKSL400	IRREVERSIBLE, 24 Vdc, WITH BUILT-IN CONTROL UNIT AND ABSOLUTE ENCODER ALLOWING INTEGRATION IN POST	16

## TECHNICAL SPECIFICATIONS

CODE	NKSL400
<b>ELECTRICAL DATA</b>	
POWER SUPPLY (Vac 50/60 Hz)	230 V
ABSORPTION (A)	1.1
POWER (W)	250 W
<b>PERFORMANCE DATA</b>	
SPEED (m/s)	0.34
FORCE (N)	400
WORK CYCLE (CYCLES/HOUR)	35
<b>DIMENSIONAL AND GENERAL DATA</b>	
PROTECTION LEVEL (IP)	10*
WORKING TEMP. (°C MIN/MAX)	-20 ÷ +50
DIMENSIONS (mm)	131x172x405 h
WEIGHT (kg)	6.5

\* The protection degree of the automation is determined by the composition motor and column.

## DIMENSIONS

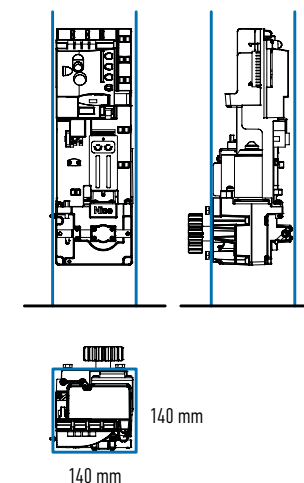
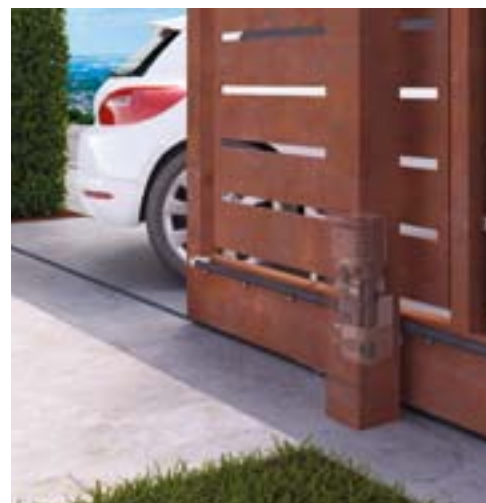

## ACCESSORIES

## KIT SOLEMYO



**NKA3**  
SPARE CONTROL UNIT.  
PC/PACK 1



**PS124**  
24 V BATTERY  
WITH INTEGRATED  
BATTERY CHARGER.  
PC/PACK 1



**ROA6**  
M4 25x20x1000 mm SLOTTED  
NYLON RACK WITH METAL  
INSERT FOR GATES  
WEIGHING UP TO 500 kg.  
PC/PACK 10



**ROA7**  
M4 RACK, ZINC COATED,  
22x22x1000 mm.  
PC/PACK 10



**ROA8**  
M4 RACK, 30x8x1000 mm,  
ZINC COATED WITH  
SPACERS AND SCREWS.  
PC/PACK 10



**KIO**  
KEY-OPERATED SELECTOR  
SWITCH FOR LOW VOLTAGE  
CONTACTS, WITH RELEASE  
MECHANISM FOR METAL  
CORD.  
PC/PACK 1



**KA1**  
6 m CABLE RELEASE KIT  
FOR KIO.  
PC/PACK 1



**TS**  
SIGNBOARD.  
PC/PACK 1



● THE SOLAR POWER  
KIT SOLEMYO TO AUTOMATE  
GATES, GARAGE DOORS  
OR BARRIER GATES,  
INCLUDING THOSE LOCATED  
FAR FROM THE POWER MAINS  
AND WITHOUT THE NEED  
FOR COSTLY AND INVASIVE  
EXCAVATION WORK.  
SEE PAGE 171

## INSTALLATION DIAGRAM

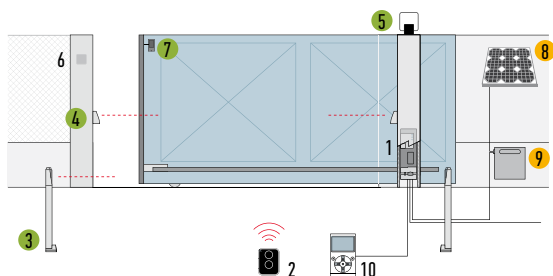

1. MOTOR
2. TRANSMITTER
3. PHOTOCELLS MOUNTED ON POSTS
4. PHOTOCELLS
5. FLASHING LIGHT
6. DIGITAL OR KEY SWITCHES
7. SENSITIVE EDGES SENSOR
8. SYP SOLAR PANEL
9. PSY24 BATTERY BOX
10. 0-VIEW MULTIFUNCTION DISPLAY

- ACCESSORIES ALSO AVAILABLE FOR THE Solemyo Air Net System WIRELESS VERSION
- Solemyo SOLAR POWER ACCESSORIES

Nice recommends customers order products in pallets in order to facilitate storage and delivery, and ensure packs are uniform. The number of packs per single pallet has been specified for this reason. Approximate draft.

# ROBUS 400/600/1000

SOLEMYO OPERA BLUEBUS 24V

**For sliding gates weighing up to 400 kg (RB400), up to 600 kg (RB600) and up to 1000 kg (RB1000).**

**Versions with electromechanical limit switch (RB400/RB600/RB1000) and with inductive limit switch (RB400P/RB600P/RB1000P).**

**User-friendly:** the Nice BlueBUS technology, enables to power and control a maximum of seven couples of photocells from the MoonBus series using two wires only.

**Practical:** the control unit and PS124 buffer battery (optional) can be connected by means of a simple connector and can be housed directly inside the motor.

**Advanced:** RB400, RB600 and RB1000 are equipped with a temperature sensor: adapt the motor power to the climatic conditions and at the same time thermal cut-out. A master/slave selection automatically synchronises two motors. This means it is possible to automate 2-leaf sliding gates set opposite each other.

**Intelligent:** thanks to the obstacle detection system and automatic programming of the working times. Self-diagnosis by means of a flashing light. 8 programming levels.

**Safe:** acceleration and deceleration can be adjusted at the beginning and end of each opening and closing manoeuvre.

**Sturdy:** base and release in pressure die cast with easy to open handle.

**Very quiet:** gear motor on bearings.

ALUMINIUM RELEASE HANDLE FOR EASY OPENING

COMPARTMENT FOR THE PULL-OUT CONTROL UNIT, PROTECTED BY CASING, AND FOR BUFFER BATTERIES



CODE	DESCRIPTION	PACK/PALLET
<b>RB400</b>	IRREVERSIBLE, 24 Vdc, WITH INCORPORATED CONTROL UNIT, WITH ELECTROMECHANICAL LIMIT SWITCH, FOR GATES UP TO 400 kg	15
<b>RB600</b>	IRREVERSIBLE, 24 Vdc, WITH INCORPORATED CONTROL UNIT, WITH ELECTROMECHANICAL LIMIT SWITCH, FOR GATES UP TO 600 kg	15
<b>RB600P</b>	IRREVERSIBLE, 24 Vdc, WITH INCORPORATED CONTROL UNIT, WITH INDUCTIVE LIMIT SWITCH, FOR GATES UP TO 600 kg	15
<b>RB1000</b>	IRREVERSIBLE, 24 Vdc, WITH INCORPORATED CONTROL UNIT, WITH ELECTROMECHANICAL LIMIT SWITCH, FOR GATES UP TO 1000 kg	15
<b>RB1000P</b>	IRREVERSIBLE, 24 Vdc, WITH INCORPORATED CONTROL UNIT, WITH INDUCTIVE LIMIT SWITCH, FOR GATES UP TO 1000 kg	15

## TECHNICAL SPECIFICATIONS

CODE	RB400	RB600/600P	RB1000/1000P
<b>ELECTRICAL DATA</b>			
POWER SUPPLY (Vac 50/60 Hz)		230	
ABSORPTION (A)	1.1	2.5	2.3
POWER (W)	250	515	450
<b>PERFORMANCE DATA</b>			
SPEED (m/s)	0.34	0.31	0.28
FORCE (N)	400	600	900
WORK CYCLE (CYCLES/HOUR)	35	40	50
<b>DIMENSIONAL AND GENERAL DATA</b>			
PROTECTION LEVEL (IP)		44	
WORKING TEMP. (°C MIN/MAX)		-20 ÷ +50	
DIMENSIONS (mm)		330x210x303 h	
WEIGHT (kg)	8	11	13

## DIMENSIONS

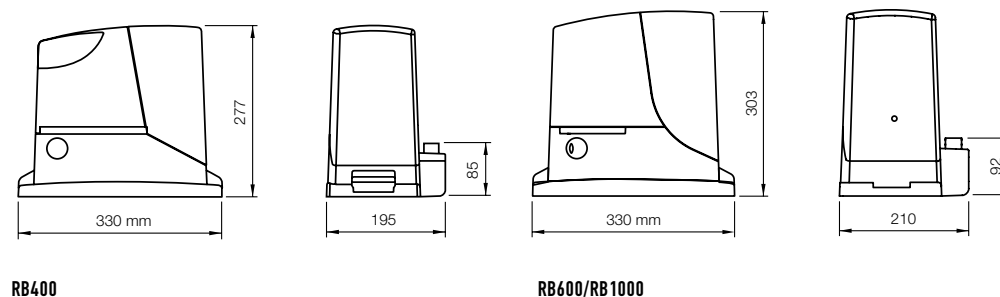

## ACCESSORIES



**RBA3**  
SPARE CONTROL UNIT  
FOR RB400, RB600/600P,  
RB1000/1000P  
AND RUN1500/1500P.  
PC/PACK 1



**PS124**  
24 V BATTERY  
WITH INTEGRATED  
BATTERY CHARGER.  
PC/PACK 1



**RBA1**  
INDUCTIVE LIMIT SWITCH.  
PC/PACK 1



**ROA6**  
(FOR RB400)  
M4 25x20x1000 mm SLOTTED  
NYLON RACK WITH METAL  
INSERT FOR GATES WEIGHING  
UP TO 500 kg.  
PC/PACK 10



**ROA7**  
M4 RACK, ZINC COATED,  
22x22x1000 mm.  
PC/PACK 10



**ROA8**  
M4 RACK, 30x8x1000 mm,  
ZINC COATED WITH SPACERS  
AND SCREWS.  
PC/PACK 10



**TS**  
SIGNBOARD.  
PC/PACK 1



● THE SOLAR POWER  
KIT SOLEMYO TO AUTOMATE  
GATES, GARAGE DOORS  
OR BARRIER GATES,  
INCLUDING THOSE LOCATED  
FAR FROM THE POWER MAINS  
AND WITHOUT THE NEED  
FOR COSTLY AND INVASIVE  
EXCAVATION WORK.  
SEE PAGE 171

## INSTALLATION DIAGRAM

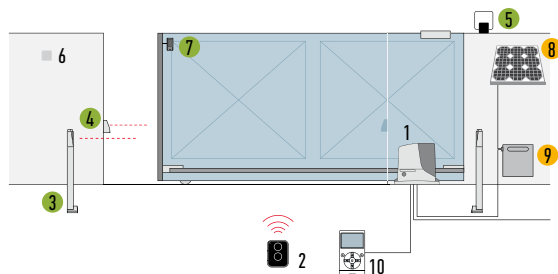

1. MOTOR
2. TRANSMITTER
3. PHOTOCELLS MOUNTED ON POSTS
4. PHOTOCELLS
5. FLASHING LIGHT
6. DIGITAL OR KEY SWITCHES
7. SENSITIVE EDGES SENSOR
8. SYP SOLAR PANEL
9. PSY24 BATTERY BOX
10. 0-VIEW MULTIFUNCTION DISPLAY

- ACCESSORIES ALSO AVAILABLE FOR THE Solemyo Air Net System WIRELESS VERSION
- Solemyo SOLAR POWER ACCESSORIES

Nice recommends customers order products in pallets in order to facilitate storage and delivery, and ensure packs are uniform. The number of packs per single pallet has been specified for this reason. Approximate draft.

# ROBUSKIT 400

SOLEMYO OPERA BLUEBUS 24V

## For sliding gates weighing up to 400 kg.

**User-friendly:** the Nice BlueBUS technology, enables to power and control a maximum of seven couples of photocells from the MoonBus series using two wires only.

**Practical:** the control unit and PS124 buffer battery (optional) can be connected by means of a simple connector and can be housed directly inside Robus.

**Advanced:** RB400 is equipped with a temperature sensor: adapt the motor power to the climatic conditions and at the same time thermal cut-out.

A master/slave selection automatically synchronises two motors. This means it is possible to automate 2-leaf sliding gates set opposite each other.

**Intelligent:** thanks to the obstacle detection system and automatic programming of the working times. Self-diagnosis by means of a flashing light. 8 programming levels.

**Safe:** acceleration and deceleration can be adjusted at the beginning and end of each opening and closing manoeuvre.

**Sturdy:** base and release in pressure die cast aluminium and epoxy paint finish.

**Very quiet:** gear motor on bearings.

CODE	DESCRIPTION	PACK/PALLET
RB400KCE	KIT FOR THE AUTOMATION OF SLIDING GATES UP TO 400 kg, 24 Vdc, INCORPORATED CONTROL UNIT	14

**N.B.** The content of the package may vary: consult the retailer.

### TECHNICAL SPECIFICATIONS

CODE	RB400
<b>ELECTRICAL DATA</b>	
POWER SUPPLY (Vac 50/60 Hz)	230
ABSORPTION (A)	1.1
POWER (W)	250
<b>PERFORMANCE DATA</b>	
SPEED (m/s)	0.34
FORCE (N)	400
WORK CYCLE (CYCLES/HOUR)	35
<b>DIMENSIONAL AND GENERAL DATA</b>	
PROTECTION LEVEL (IP)	44
WORKING TEMP. (°C MIN/MAX)	-20 ÷ +50
DIMENSIONS (mm)	330x195x277 h
WEIGHT (kg)	8

### DIMENSIONS

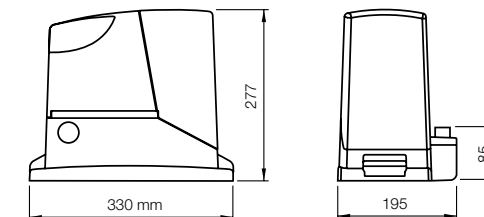

### THE KIT CONTAINS:

**RB400**  
1 IRREVERSIBLE ELECTROMECHANICAL GEAR MOTOR, WITH INCORPORATED CONTROL UNIT AND OXI PLUG-IN RECEIVER WHICH CAN BE USED FOR CONNECTIONS VIA NICE BLUEBUS.



**ON2E**  
1 TRANSMITTER 433.92 MHz, 2 CHANNELS.



**MOFB**  
1 COUPLE OF EXTERNAL PHOTOCELLS DESIGNED FOR CONNECTION BY NICE BLUEBUS.



**MOSE**  
1 KEY SELECTOR SWITCH FOR OUTDOOR INSTALLATION.



**MLBT**  
1 FLASHING LIGHT WITH INTEGRATED AERIAL.



**TS**  
1 SIGNBOARD.





## ACCESSORIES



**RBA3**  
SPARE CONTROL UNIT  
FOR RB400, RB600/600P,  
RB1000/1000P  
AND RUN1500/1500P.  
PC/PACK 1



**PS124**  
24 V BATTERY  
WITH INTEGRATED  
BATTERY CHARGER.  
PC/PACK 1



**RBA1**  
INDUCTIVE LIMIT SWITCH.  
PC/PACK 1



**ROA6**  
M4 25x20x1000 mm SLOTTED  
NYLON RACK WITH METAL  
INSERT FOR GATES WEIGHING  
UP TO 500 kg.  
PC/PACK 10



**ROA7**  
M4 RACK, ZINC COATED,  
22x22x1000 mm.  
PC/PACK 10



**ROA8**  
M4 RACK, 30x8x1000 mm,  
ZINC COATED WITH SPACERS  
AND SCREWS.  
PC/PACK 10



● THE SOLAR POWER  
KIT SOLEMYO TO AUTOMATE  
GATES, GARAGE DOORS  
OR BARRIER GATES,  
INCLUDING THOSE LOCATED  
FAR FROM THE POWER MAINS  
AND WITHOUT THE NEED  
FOR COSTLY AND INVASIVE  
EXCAVATION WORK.  
SEE PAGE 171

## INSTALLATION DIAGRAM

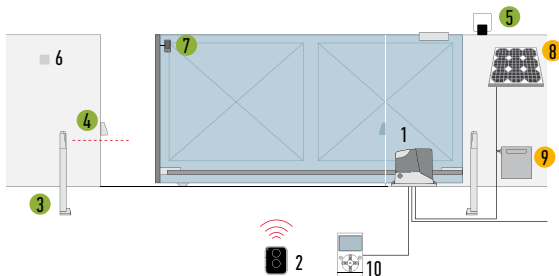

1. MOTOR
2. TRANSMITTER
3. PHOTOCELLS MOUNTED ON POSTS
4. PHOTOCELLS
5. FLASHING LIGHT
6. DIGITAL OR KEY SWITCHES
7. SENSITIVE EDGES SENSOR
8. SYP SOLAR PANEL
9. PSY24 BATTERY BOX
10. 0-VIEW MULTIFUNCTION DISPLAY

- ACCESSORIES ALSO AVAILABLE FOR THE Solemyo Air Net System WIRELESS VERSION
- Solemyo SOLAR POWER ACCESSORIES



# ROBUSKIT 600

SOLEMYO OPERA BLUEBUS 24V

## For sliding gates weighing up to 600 kg.

**User-friendly:** the Nice BlueBUS technology, enables to power and control a maximum of seven couples of photocells from the MoonBus series using two wires only.

**Practical:** the control unit and PS124 buffer battery (optional) can be connected by means of a simple connector and can be housed directly inside the motor.

**Advanced:** RB600 is equipped with a temperature sensor: adapt the motor power to the climatic conditions and at the same time thermal cut-out; a master/slave selection automatically synchronises two motors. This means it is possible to automate 2-leaf sliding gates set opposite each other.

**Intelligent:** thanks to the obstacle detection system and automatic programming of the working times. Self-diagnosis by means of a flashing light. 8 programming levels.

**Safe:** acceleration and deceleration can be adjusted at the beginning and end of each opening and closing manoeuvre.

**Sturdy:** base and release in pressure die cast with easy to open handle.

**Very quiet:** gear motor on bearings.

CODE	DESCRIPTION	PACK/PALLET
RB600KCE	KIT FOR THE AUTOMATION OF SLIDING GATES UP TO 600 kg, 24 Vdc, INCORPORATED CONTROL UNIT	14

**N.B.** The content of the package may vary; consult the retailer.

## TECHNICAL SPECIFICATIONS

CODE	RB600
<b>ELECTRICAL DATA</b>	
POWER SUPPLY (Vac 50/60 Hz)	230
ABSORPTION (A)	2.5
POWER (W)	515
<b>PERFORMANCE DATA</b>	
SPEED (m/s)	0.31
FORCE (N)	600
WORK CYCLE (CYCLES/HOUR)	40
<b>DIMENSIONAL AND GENERAL DATA</b>	
PROTECTION LEVEL (IP)	44
WORKING TEMP. (°C MIN/MAX)	-20 ÷ +50
DIMENSIONS (mm)	330x210x303H
WEIGHT (kg)	11

## DIMENSIONS

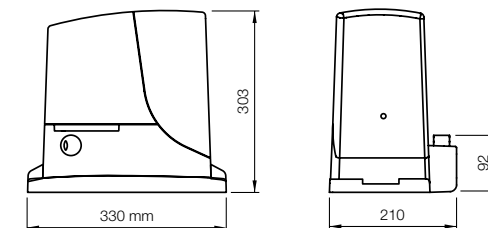

## THE KIT CONTAINS:

**RB600**  
1 IRREVERSIBLE ELECTROMECHANICAL GEAR MOTOR, 1 WITH INCORPORATED CONTROL UNIT AND OXI PLUG-IN RECEIVER WHICH CAN BE USED FOR CONNECTIONS VIA NICE BLUEBUS.



**ONZE**  
1 TRANSMITTER 433.92 MHz, 2 CHANNELS.



**MOFB**  
1 COUPLE OF EXTERNAL PHOTOCELLS DESIGNED FOR CONNECTION BY NICE BLUEBUS.



**MOSE**  
1 KEY SELECTOR SWITCH FOR OUTDOOR INSTALLATION.



**MLBT**  
1 FLASHING LIGHT WITH INTEGRATED AERIAL.



**TS**  
1 SIGNBOARD.



## ACCESSORIES



**RBA3**  
SPARE CONTROL UNIT  
FOR RB400, RB600/600P,  
RB1000/1000P  
AND RUN1500/1500P.  
PC/PACK 1



**PS124**  
24 V BATTERY  
WITH INTEGRATED  
BATTERY CHARGER.  
PC/PACK 1



**RBA1**  
INDUCTIVE LIMIT SWITCH.  
PC/PACK 1



**ROA7**  
M4 RACK, ZINC COATED,  
22x22x1000 mm.  
PC/PACK 10



**ROA8**  
M4 RACK, 30x8x1000 mm,  
ZINC COATED WITH  
SPACERS AND SCREWS.  
PC/PACK 10



● THE SOLAR POWER  
KIT SOLEMYO TO AUTOMATE  
GATES, GARAGE DOORS OR  
BARRIER GATES,  
INCLUDING THOSE LOCATED  
FAR FROM THE POWER MAINS  
AND WITHOUT THE NEED  
FOR COSTLY AND INVASIVE  
EXCAVATION WORK.  
SEE PAGE 171

## INSTALLATION DIAGRAM

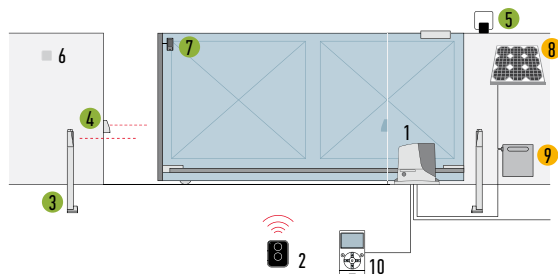

1. MOTOR
2. TRANSMITTER
3. PHOTOCELLS MOUNTED ON POSTS
4. PHOTOCELLS
5. FLASHING LIGHT
6. DIGITAL OR KEY SWITCHES
7. SENSITIVE EDGES SENSOR
8. SYP SOLAR PANEL
9. PSY24 BATTERY BOX
10. 0-VIEW MULTIFUNCTION DISPLAY

- ACCESSORIES ALSO AVAILABLE FOR THE Solemyo Air Net System WIRELESS VERSION
- Solemyo SOLAR POWER ACCESSORIES



# ROADKIT

24V

**For sliding gates weighing up to 400 kg and up to 6 m length.**

**Practical:** built-in control unit, can be connected by means of a simple connector and can be housed directly inside the motor; incorporated radio card, compatible with the Nice Flo and Smilo systems: 150 transmitters can be entered!

**Advanced:** the speed, strength and pause can all be adjusted.

**Intelligent:** thanks to the obstacle detection system and automatic programming of the working times. Self-diagnosis by means of a flashing light.

**Safe:** acceleration and deceleration can be adjusted at the beginning and end of each opening and closing manoeuvre.

CODE	DESCRIPTION
<b>RD300</b>	KIT FOR THE AUTOMATION OF SLIDING GATES UP TO 400 kg AND UP TO 6 m LENGTH, 24 Vdc, WITH INCORPORATED CONTROL UNIT AND RECEIVER

**N.B.** The content of the package may vary; consult the retailer.

## TECHNICAL SPECIFICATIONS

CODE	RD300
<b>ELECTRICAL DATA</b>	
POWER SUPPLY (Vac 50/60 Hz)	230
ABSORPTION (A)	1.1
POWER (W)	210
<b>PERFORMANCE DATA</b>	
SPEED (m/s)	0.25
FORCE (N)	300
WORK CYCLE (CYCLES/HOUR)	20
<b>DIMENSIONAL AND GENERAL DATA</b>	
PROTECTION LEVEL (IP)	44
WORKING TEMP. (°C MIN/MAX)	-20 ÷ +50
DIMENSIONS (mm)	330x195x277 h
WEIGHT (kg)	8

## DIMENSIONS

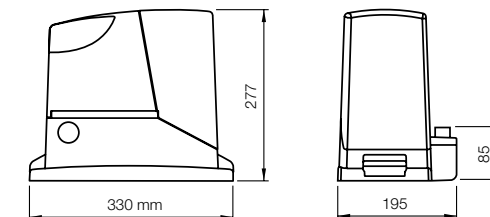

## THE KIT CONTAINS:

**RD300**  
1 IRREVERSIBLE ELECTROMECHANICAL GEAR MOTOR, 24 Vdc, WITH INCORPORATED CONTROL UNIT AND RECEIVER.



**FL02RE**  
1 TRANSMITTER 433.92 MHz, 2 CHANNELS.



**MOF**  
1 PAIR OF PHOTOCELLS FOR OUTDOOR INSTALLATION.



**MOSE**  
1 KEY SELECTOR SWITCH FOR OUTDOOR INSTALLATION.



**MLBT**  
1 FLASHING LIGHT WITH INTEGRATED AERIAL.



**TS**  
1 SIGNBOARD.



## ACCESSORIES



**RBA4**  
SPARE CONTROL UNIT  
FOR RDKCE.



**CM-B**  
PAWL WITH TWO METAL  
RELEASE KEYS.



**ROA6**  
M4 25X20X1000 mm SLOTTED  
NYLON RACK WITH METAL  
INSERT FOR GATES WEIGHING  
UP TO 500 kg.  
PC/PACK 10



**ROA7**  
M4 RACK, ZINC COATED,  
22X22X1000 mm.  
PC/PACK 10



**ROA8**  
M4 RACK, 30X8X1000 mm,  
ZINC COATED WITH  
SPACERS AND SCREWS.  
PC/PACK 10

## INSTALLATION DIAGRAM

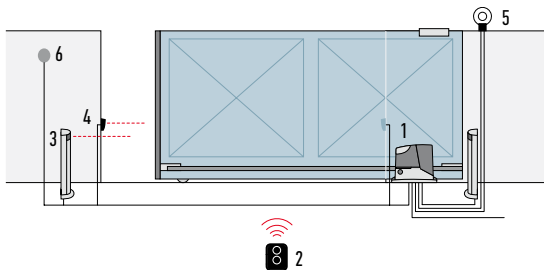

1. MOTOR
2. TRANSMITTER
3. PHOTOCELLS MOUNTED ON POSTS
4. PHOTOCELLS
5. FLASHING LIGHT
6. DIGITAL OR KEY SWITCHES



# RUN 1500

SOLEMYO OPERA BLUEBUS 24V

**For sliding gates weighing up to 1500 kg.**

**Versions with electromechanical limit switch (RUN1500) and with inductive limit switch (RUN1500P).**

**User-friendly:** the BlueBUS technology, enables to power and control a maximum of 7 couples of photocells from the MoonBus series using two wires only.

**Practical:** the control unit and PS124 buffer battery (optional) can be connected by means of a simple connector and can be housed directly inside the motor.

**Advanced:** the temperature sensor adapts the motor force to weather conditions, setting the thermal cut-out protection accordingly; a master/slave selection automatically synchronises 2 motors, enabling the automation of sliding gates with two opposing leaves.

**Intelligent:** thanks to the obstacle detection system and automatic programming of the working times. Self-diagnosis by means of a flashing light. 8 programming levels.

**Safe:** acceleration and deceleration can be adjusted at the beginning and end of each opening and closing manoeuvre.

**Sturdy:** aluminium release handle for easy opening.

**Very quiet:** gear motor on bearings.

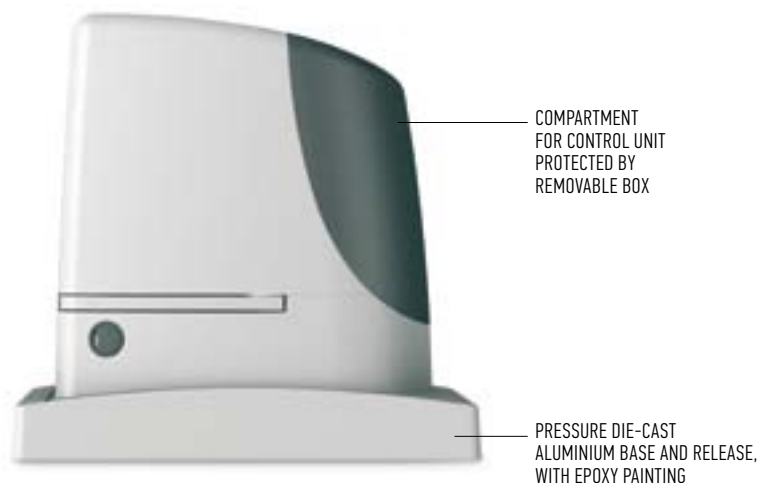

CODE	DESCRIPTION	PACK/PALLET
<b>RUN1500</b>	IRREVERSIBLE, 24 Vdc, WITH BUILT-IN CONTROL UNIT, WITH ELECTROMECHANICAL LIMIT SWITCH, FOR SLIDING GATES WEIGHING UP TO 1500 kg	12
<b>RUN1500P</b>	IRREVERSIBLE, 24 Vdc, WITH BUILT-IN CONTROL UNIT, WITH INDUCTIVE LIMIT SWITCH, FOR SLIDING GATES WEIGHING UP TO 1500 kg	12

## TECHNICAL SPECIFICATIONS

CODE	RUN1500/1500P
<b>ELECTRICAL DATA</b>	
POWER SUPPLY (Vac 50/60 Hz)	230
ABSORPTION (A)	2
POWER (W)	400
<b>PERFORMANCE DATA</b>	
SPEED (m/s)	0.25
FORCE (N)	1000
WORK CYCLE (CYCLES/HOUR)	60
<b>DIMENSIONAL AND GENERAL DATA</b>	
PROTECTION LEVEL (IP)	44
WORKING TEMP. (°C MIN/MAX)	-20 ÷ +50
DIMENSIONS (mm)	400x255x390 h
WEIGHT (kg)	19

## DIMENSIONS

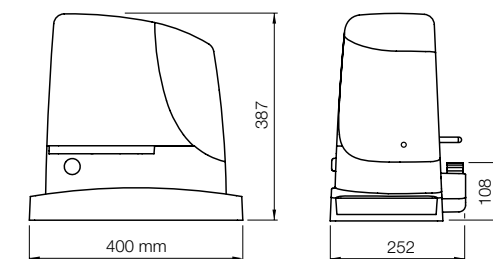



**RBA3**  
SPARE CONTROL UNIT  
FOR RB400, RB600/600P,  
RB1000/1000P  
AND RUN1500/1500P.  
PC/PACK 1



**PS124**  
24 V BATTERY  
WITH INTEGRATED  
BATTERY CHARGER.  
PC/PACK 1



**RBA1**  
INDUCTIVE LIMIT SWITCH.  
PC/PACK 1



**ROA7**  
M4 RACK, ZINC COATED,  
22X22X1000 mm.  
PC/PACK 10



**ROA8**  
M4 RACK, 30X8X1000 mm,  
ZINC COATED WITH SPACERS  
AND SCREWS.  
PC/PACK 10



**ROA81**  
M6 RACK, 30X30X1000 mm,  
ZINC COATED, TO BE  
COUPLED WITH RUA12.  
PC/PACK 1



**RUA12**  
12-TEETH PINION,  
MODULE 6, TO BE COUPLED  
WITH RACK ROA81.  
The Run automation is supplied  
with a module 4 pinion to be used  
with the standard racks ROA7  
and ROA8.  
PC/PACK 1



**TS**  
SIGNBOARD.  
PC/PACK 1



● THE SOLAR POWER  
KIT SOLEMYO TO AUTOMATE  
GATES, GARAGE DOORS  
OR BARRIER GATES,  
INCLUDING THOSE LOCATED  
FAR FROM THE POWER MAINS  
AND WITHOUT THE NEED  
FOR COSTLY AND INVASIVE  
EXCAVATION WORK.  
SEE PAGE 171

INSTALLATION DIAGRAM

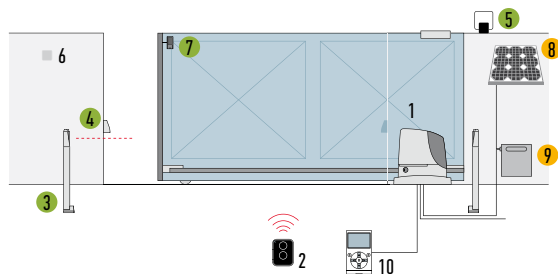

1. MOTOR
2. TRANSMITTER
3. PHOTOCELLS MOUNTED ON POSTS
4. PHOTOCELLS
5. FLASHING LIGHT
6. DIGITAL OR KEY SWITCHES
7. SENSITIVE EDGES SENSOR
8. SYP SOLAR PANEL
9. PSY24 BATTERY BOX
10. 0-VIEW MULTIFUNCTION DISPLAY

- ACCESSORIES ALSO AVAILABLE FOR THE Solemyo Air Net System WIRELESS VERSION
- Solemyo SOLAR POWER ACCESSORIES

Nice recommends customers order products in pallets in order to facilitate storage and delivery, and ensure packs are uniform. The number of packs per single pallet has been specified for this reason. Approximate draft.

# RUN 1800/2500

OPERA BLUEBUS 230V

**For sliding gates weighing up to 1800 kg (RUN1800) and up to 2500 kg (RUN2500).**

**Ventilated motor with inductive limit switch (RUN1800P/RUN2500P) or electromechanical limit switch (RUN1800/RUN2500I/RUN2500).**

**Suitable to operate in extreme conditions, in systems for intensive use.**

**Simple to install:** the BlueBUS system enables connections by means of just two wires between the control unit and up to 15 control safety and signalling devices.

**Safe:** the acceleration settings (at the start of the manoeuvre) and the deceleration settings (at the end of the manoeuvre) are precise and reliable.

**The temperature sensor:** Run is able to manage force, adapting it to the different climatic and environmental conditions, while adapting the thermal cut-out protection and intensity of self-ventilation, depending on the temperature reading.

A **master/slave** selection also automatically synchronises 2 motors, enabling the automation of sliding gates with two opposing leaves.

**Practical and functional:** the control unit (and inverter on version RUN2500I), housed inside Run, can be simply connected by means of the practical connector guide.

**Very quiet:** gear motor on bearings.

## RUN2500I version with built-in inverter

**Perfect movement:** the inverter enables the power supply and drive of the 3-phase motor with single-phase current at 230 Vac, acting on the frequency to adjust speed of the automation from a minimum of 8.2 m/min to maximum 15.4 m/min.

In the automation deceleration phase, the inverter, which dialogues with the control unit, increases the torque, thus improving performance and reducing the risk of the automation blocking on impact with obstacles.



COMPARTMENT FOR CONTROL UNIT PROTECTED BY REMOVABLE BOX

PRESSURE DIE-CAST ALUMINIUM BASE AND RELEASE, WITH EPOXY PAINTING

CODE	DESCRIPTION	PACK/PALLET
<b>RUN1800</b>	IRREVERSIBLE, 230 Vac, WITH BUILT-IN CONTROL UNIT, WITH ELECTROMECHANICAL LIMIT SWITCH, FOR SLIDING GATES WEIGHING UP TO 1800 kg	12
<b>RUN1800P</b>	IRREVERSIBLE, 230 Vac, WITH BUILT-IN CONTROL UNIT, WITH INDUCTIVE LIMIT SWITCH, FOR SLIDING GATES WEIGHING UP TO 1800 kg	12
<b>RUN2500</b>	IRREVERSIBLE, 230 Vac, WITH BUILT-IN CONTROL UNIT, WITH ELECTROMECHANICAL LIMIT SWITCH, FOR SLIDING GATES WEIGHING UP TO 2500 kg	12
<b>RUN2500P</b>	IRREVERSIBLE, 230 Vac, WITH BUILT-IN CONTROL UNIT, WITH INDUCTIVE LIMIT SWITCH, FOR SLIDING GATES WEIGHING UP TO 2500 kg	12
<b>RUN2500I</b>	IRREVERSIBLE, 230 Vac, WITH BUILT-IN CONTROL UNIT AND INVERTER, WITH ELECTROMECHANICAL LIMIT SWITCHES, FOR SLIDING GATES WEIGHING UP TO 2500 kg	12

## TECHNICAL SPECIFICATIONS

CODE	RUN1800/1800P	RUN2500/2500P	RUN2500I
<b>ELECTRICAL DATA</b>			
POWER SUPPLY (Vac/Hz)	230/50*		230/50-60
ABSORPTION (A)	3	3.8	3.7
POWER (W)	700	870	650
<b>PERFORMANCE DATA</b>			
SPEED (m/s)	0.17		0.26
FORCE (N)	1110	1390	1660
WORK CYCLE (CYCLES/HOUR)	42		56
<b>DIMENSIONAL AND GENERAL DATA</b>			
PROTECTION LEVEL (IP)	44		
WORKING TEMP. (°C MIN/MAX)	-20 ÷ +50		
DIMENSIONS (mm)	400x255x390 h		
WEIGHT (kg)	24.5		25

\*60 Hz version available on request.

## DIMENSIONS

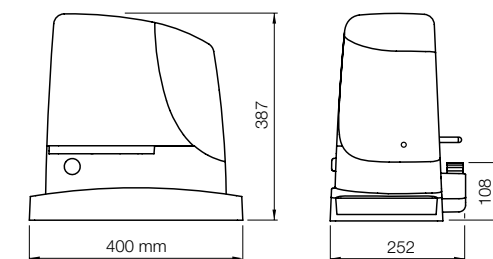



## ACCESSORIES



**RUA1**  
SPARE CONTROL UNIT  
FOR RUN1800/1800P  
AND RUN2500/2500P.

PC/PACK 1



**RUA2**  
SPARE CONTROL UNIT  
FOR RUN2500I.

PC/PACK 1



**RUA3**  
SPARE INVERTER  
FOR RUN2500I.

PC/PACK 1



**ROA7**  
M4 RACK, ZINC COATED,  
22X22X1000 mm.

PC/PACK 10



**ROA8**  
M4 RACK, 30X8X1000 mm,  
ZINC COATED WITH SPACERS  
AND SCREWS.

PC/PACK 10



**ROA81**  
M6 RACK, 30X30X1000 mm,  
ZINC COATED, TO BE  
COUPLED WITH RUA12.

PC/PACK 1



**RUA12**  
12-TEETH PINION,  
MODULE 6, TO BE COUPLED  
WITH RACK ROA81.

The Run automation is supplied  
with a module 4 pinion to be used  
with the standard racks ROA7  
and ROA8.

PC/PACK 1



**TS**  
SIGNBOARD.

PC/PACK 1

## INSTALLATION DIAGRAM

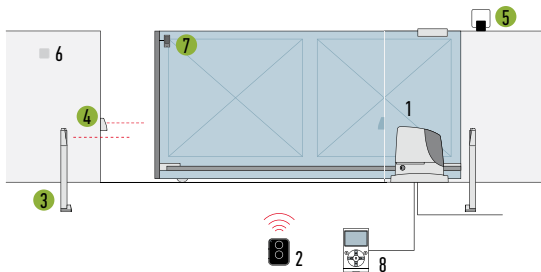

1. MOTOR
2. TRANSMITTER
3. PHOTOCELLS MOUNTED ON POSTS
4. PHOTOCELLS
5. FLASHING LIGHT
6. DIGITAL OR KEY SWITCHES
7. SENSITIVE EDGES SENSOR
8. O-VIEW MULTIFUNCTION DISPLAY

● ACCESSORIES ALSO AVAILABLE FOR THE Solemyo Air Net System WIRELESS VERSION

Nice recommends customers order products in pallets in order to facilitate storage and delivery, and ensure packs are uniform. The number of packs per single pallet has been specified for this reason. Approximate draft.

# TUB

400V

## For sliding gates weighing up to 3500 kg. Ideal for industrial use.

Irreversible electromechanical 400 Vac gear motor with built-in Mindy A500 control unit.

### Powerful:

550 W absorbed output and a peak thrust of over 400 Nm.

### Functionality and safety:

programmable, electronic brake which prevents gate inertia; self-ventilated motor to increase the working cycles; optional PIU card to increase the basic functions.

### Maximum durability and silence:

bronze and metal gears.

### Advanced:

Tub meets all requirements in terms of control, thanks to the functions which can be selected by means of dipswitches.

### Practical:

the lever release enables safe and simple operation.



CODE	DESCRIPTION
<b>TUB3500</b>	IRREVERSIBLE, ELECTROMECHANICAL LIMIT SWITCH, 400 Vac, WITH BUILT-IN MINDY A500 CONTROL UNIT

### TECHNICAL SPECIFICATIONS

CODE	TUB3500
<b>ELECTRICAL DATA</b>	
POWER SUPPLY (Vac 50 Hz)*	400
ABSORPTION (A)	1.65
POWER (W)	550
<b>PERFORMANCE DATA</b>	
SPEED (m/s)	0.17
FORCE (N)	7740
WORK CYCLE (CYCLES/DAY)	200
<b>DIMENSIONAL AND GENERAL DATA</b>	
PROTECTION LEVEL (IP)	44
WORKING TEMP. (°C MIN/MAX)	-20 ÷ +50
DIMENSIONS (mm)	480x240x580 h
WEIGHT (kg)	60

### DIMENSIONS

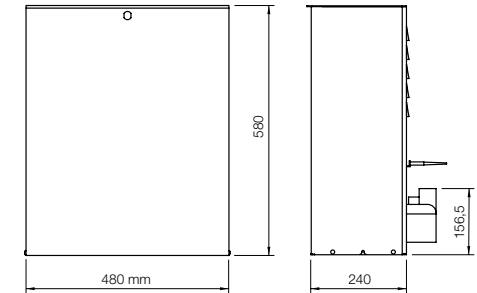

\*Usable also at 60 Hz with consequent change in performance ratings.

### INSTALLATION DIAGRAM

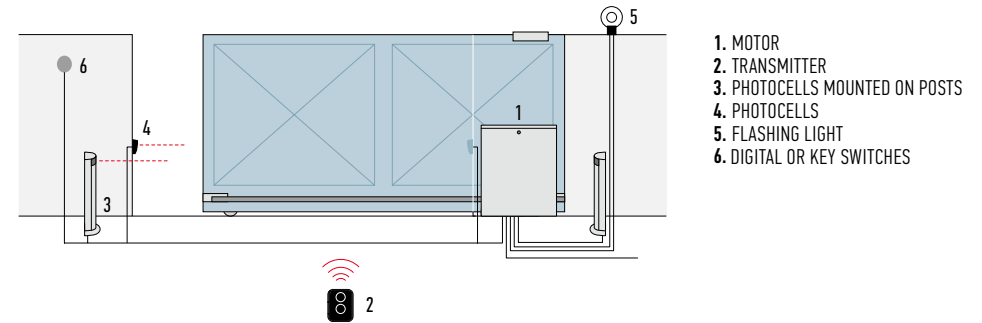

### ACCESSORIES



**A500**  
SPARE CONTROL UNIT.  
PC/PACK 1



**PIU**  
EXPANSION CARD  
FOR CONTROL UNIT.  
PC/PACK 1



**ROA81**  
M6 RACK, 30x30x1000 mm,  
ZINC COATED.  
PC/PACK 1



**TS**  
SIGNBOARD.  
PC/PACK 1

# RACKS

## For sliding gates or on motors with pinion.

Plastic racks are available for gates up to 500 kg (ROA6) and **galvanised** racks, ideal for any type of sliding gate, residential and industrial: ROA7 for direct welding on the gate, and the **practical** ROA8 (the spacers are welded onto the gate, and then the rack is screwed onto the spacers).



**ROA6**  
M4 25x20x1000 mm SLOTTED  
NYLON RACK WITH METAL  
INSERT FOR GATES WEIGHING  
UP TO 500 kg.  
PC/PACK 10



**ROA7**  
M4 RACK, ZINC COATED,  
22x22x1000 mm.  
PC/PACK 10



**ROA8**  
M4 RACK, 30x8x1000 mm,  
ZINC COATED WITH SPACERS  
AND SCREWS.  
PC/PACK 10



**ROA81**  
M6 RACK, 30x30x1000 mm,  
ZINC COATED.  
PC/PACK 1



# BARRIER GATE OPERATOR SYSTEMS



NICEBAR SYSTEM

96 S -BAR  
98 M -BAR  
102 L -BAR

---

OTHER BARRIERS

106 SIGNO  
110 WIL

# S/M/L BAR BARRIER GATE OPERATORS FOR ALL SIZES

HIGH PERFORMING, RELIABLE AND DURABLE.  
ELEGANT, STREAMLINED DESIGN.  
CAREFULLY SELECTED MATERIALS.  
GREATER CONVENIENCE, SAFETY AT ALL TIMES.

## Integrated solutions for all requirements.

New range of barrier gate operators to control road access to car parks, industrial, private and block of flats transit areas, including high traffic ones.

## 5 models in 3 standard versions, up to 7 modular bars from 3 to 9 m.

Easy transport and optimised management in the warehouse.

NICE KEY RELEASE

TAMPER-PROOF  
FUNCTION: PROVISION FOR  
INTEGRATED ASSEMBLY OF  
PHOTOCELLS

PAINT-FINISHED ALUMINIUM  
FOR BAR SUPPORT  
AND COVER, WITH OPTIONAL  
FLASHING LIGHT

STEEL CASE WITH PROTECTIVE  
CATAPHORESIS TREATMENT  
AND PAINT FINISH, OR WITH  
STAINLESS STEEL CASE

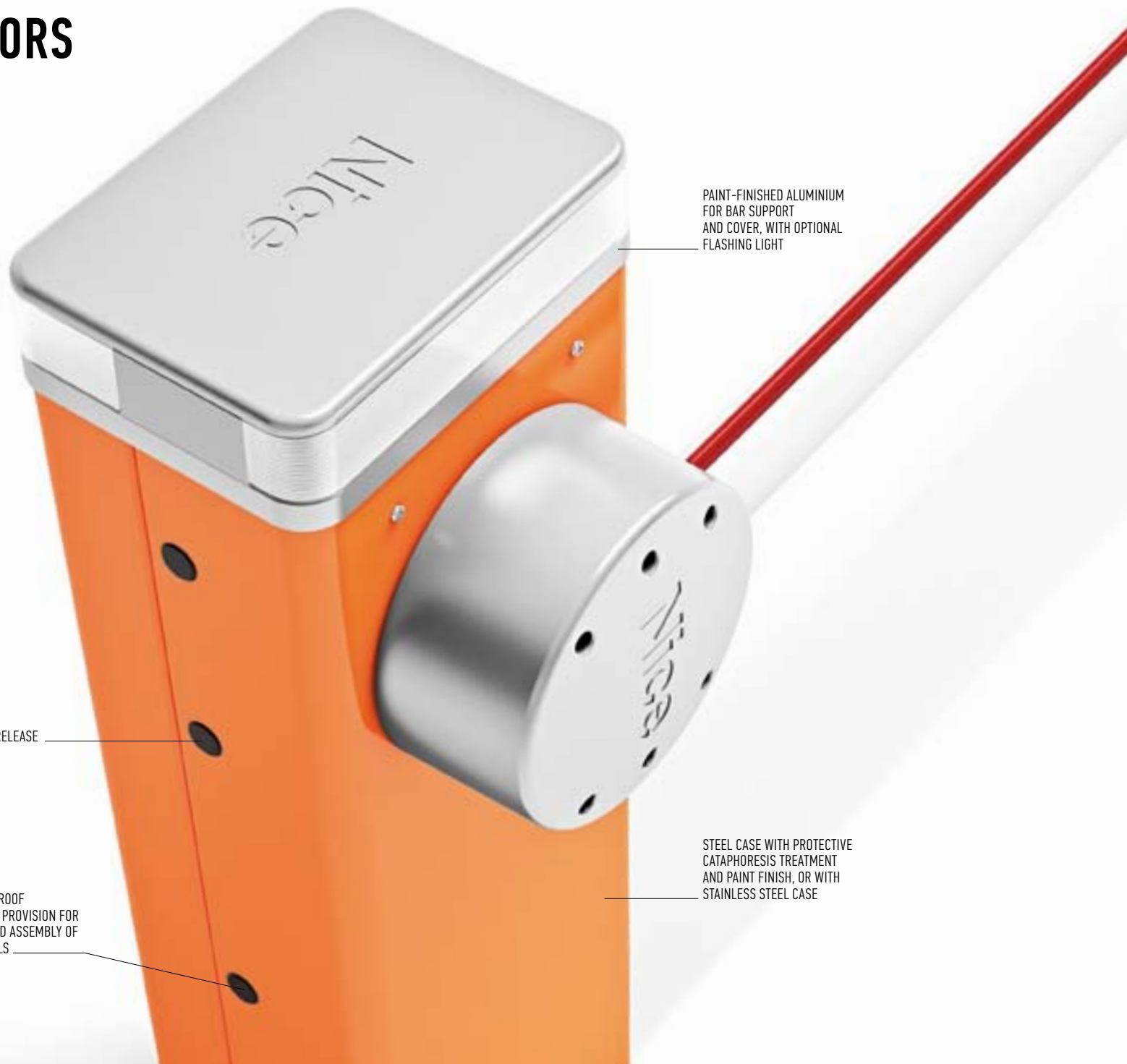

# SELECTION GUIDE, COMPOSITION OF BARS AND ACCESSORIES

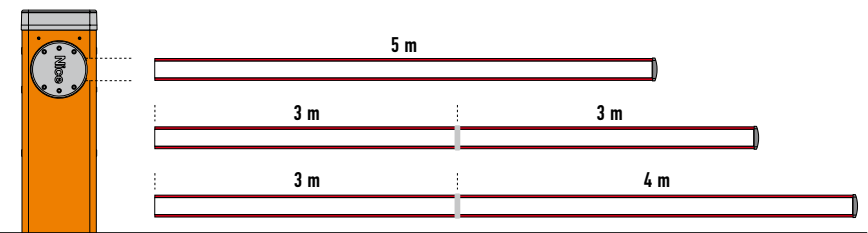
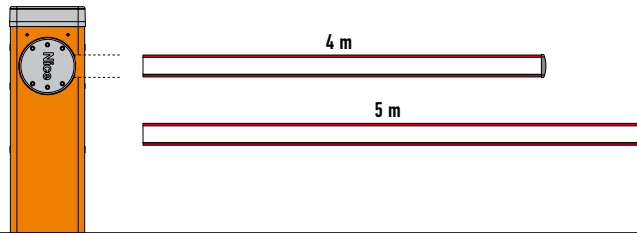
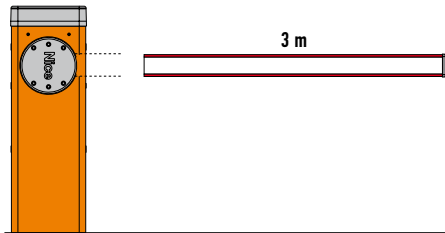
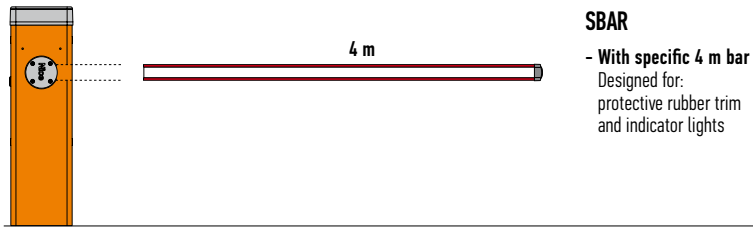

**M3BAR**  
 - With 3 m bar  
 Designed for:  
 protective rubber trim  
 and indicator lights

**M5BAR**  
 - With 4 m bar  
 Designed for:  
 protective rubber trim,  
 indicator lights,  
 rack, mobile stand

- With 5 m bar  
 Designed for:  
 protective rubber trim  
 and indicator lights

**M7BAR**  
 - With 5 m bar  
 Designed for:  
 protective rubber trim,  
 indicator lights, rack,  
 mobile stand

- With bar up to 6 m (3+3 m)\*  
 Designed for:  
 protective rubber trim,  
 indicator lights, rack,  
 mobile stand

- With bar up to 7 m (3+4 m)\*  
 Designed for:  
 protective rubber trim  
 and indicator lights

\*Use XBA9 joint to assemble bars

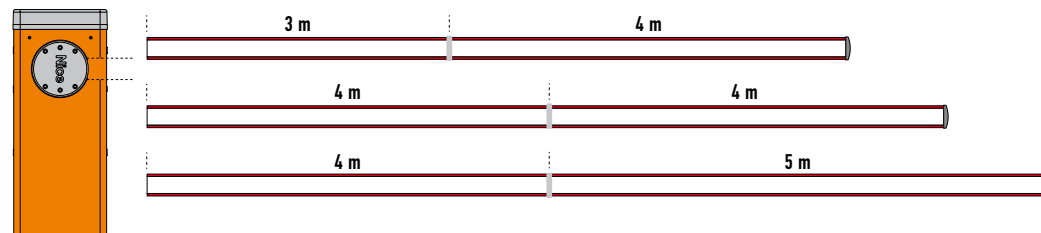

**LBAR**  
 - With bar of 7 m (3+4 m)\*  
 Designed for:  
 protective rubber trim,  
 indicator lights, rack,  
 mobile stand

- With bar of 8 m (4+4 m)\*  
 Designed for:  
 protective rubber trim,  
 indicator lights, rack,  
 mobile stand

- With bar of 9 m (4+5 m)\*  
 Designed for:  
 protective rubber trim  
 and indicator lights

\*Use XBA9 joint to assemble bars

# S-BAR

SOLEMYO OPERA BLUEBUS 24V

## Electromechanical road barrier system for control of road access.

24 Vdc gear motor with built-in control unit.

For bar up to 4 m.

**Strength and reliability:** robust structure in steel, new high strength balancing springs guaranteed up to 500,000 opening and closing operations and elliptical section bar with high wind-gust resistance.

Optional flashing or traffic light can be integrated in cover.

**More comfort and safety in programming and maintenance**

**phases:** the separate enclosures for electronics and mechanics protect internal parts from potential risks.

**Rapid and easy access** to the control unit located in the upper section of the barrier body.

Simple fixture of the completely concealed photocells onto the specially designed seats on the barrier body.

**More safety and reliability:** obstacle detection and monitoring of motor absorption during automation movement.

Automatic fault diagnostics during operation with consequent signalling of fault type through specific flash sequences.

Provision for connection of latest generation optical and resistive sensitive edges (with 8.2 KOhm resistance).

**Energy saving:** the system sets to standby when not in use to save consumption.

**No blackouts:** emergency backup power with the optional batteries housed inside the case.

**Release from side with Nice triangular key,** can be installed on either side.



## WITH BAR UP TO 4 m, IRREVERSIBLE 230 Vac, 24 Vdc MOTOR, WITH FOUNDATION PLATE:

CODE	DESCRIPTION
SBAR	WITH STEEL CASE WITH PROTECTIVE CATAPHORESIS TREATMENT AND PAINT FINISH
SBARI	WITH STAINLESS STEEL CASE

## TECHNICAL SPECIFICATIONS

CODE	SBAR	SBARI
<b>ELECTRICAL DATA</b>		
POWER SUPPLY (Vac 50/60 Hz)	230	
POWER SUPPLY (Vdc)	24	
ABSORPTION (A)	1	
POWER (W)	300	
<b>PERFORMANCE DATA</b>		
SPEED (S)	<4	
TORQUE (Nm)	100	
WORK CYCLE (CYCLES/HOUR)	100	
<b>DIMENSIONAL AND GENERAL DATA</b>		
PROTECTION LEVEL (IP)	44	
WORKING TEMP. (°C MIN/MAX)	-20 ÷ +50	
DIMENSIONS (mm)	330x180x1180 h	
WEIGHT (kg)	46	

## DIMENSIONS

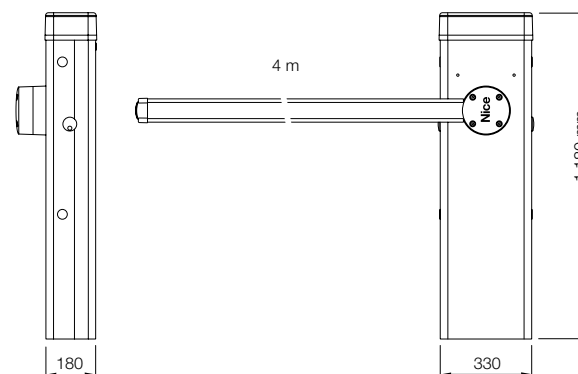



**ACCESSORIES**

**KIT SOLEMYO**



**XBA20**  
SPARE CONTROL UNIT  
FOR SBAR.  
PC/PACK 1



**PS124**  
24 V BATTERY  
WITH INTEGRATED  
BATTERY CHARGER.  
PC/PACK 1



**XBA19**  
WHITE PAINT-FINISHED  
ALUMINIUM BAR  
45x58x4000 mm.  
PC/PACK 1



**XBA13**  
RUBBER IMPACT PROTECTION  
STRIP. LENGTH 1 m.  
PC/PACK 9



**WA10**  
RED ADHESIVE  
REFLECTOR STRIPS.  
PC/PACK 24



**SIA1**  
ANCHORAGE BASE  
WITH CLAMPS.  
PC/PACK 1



**XBA7**  
INTEGRABLE FLASHING LIGHT.  
PC/PACK 1



● THE SOLAR POWER  
KIT SOLEMYO TO AUTOMATE  
GATES, GARAGE DOORS  
OR BARRIER GATES,  
INCLUDING THOSE LOCATED  
FAR FROM THE POWER MAINS  
AND WITHOUT THE NEED  
FOR COSTLY AND INVASIVE  
EXCAVATION WORK.  
SEE PAGE 171



**XBA4**  
INDICATOR LIGHTS FOR CLICK  
FIXTURE ON UPPER OR LOWER  
SIDE OF BAR. LENGTH 4 m.  
PC/PACK 1



**WA11**  
ADJUSTABLE STAND  
FOR BARS.  
PC/PACK 1

**INSTALLATION DIAGRAM**

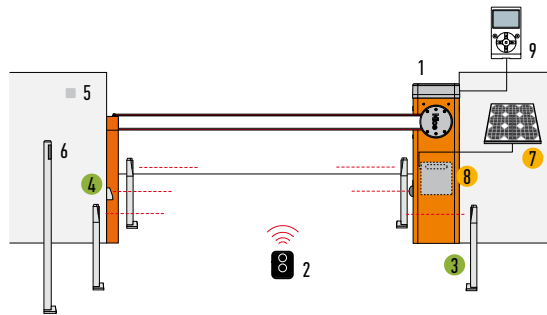

- 1. BARRIER
- 2. TRANSMITTER
- 3. PHOTOCELLS MOUNTED ON POSTS
- 4. PHOTOCELLS
- 5. DIGITAL OR KEY SWITCHES
- 6. KEY-OPERATED SELECTOR OR DIGITAL ON POST
- 7. SYP SOLAR PANEL
- 8. PSY24 BATTERY BOX
- 9. 0-VIEW MULTIFUNCTION DISPLAY

- ACCESSORIES ALSO AVAILABLE FOR THE Solemyo Air Net System WIRELESS VERSION
- Solemyo SOLAR POWER ACCESSORIES

Nice recommends customers order products in pallets in order to facilitate storage and delivery, and ensure packs are uniform. The number of packs per single pallet has been specified for this reason. Approximate draft.

# M-BAR

SOLEMYO OPERA BLUEBUS 24V

## Electromechanical road barrier system for control of road access.

24 Vdc gear motor with built-in control unit and loop detector.

### For bars up from 3 to 7 m.

**Modular:** bars are easily assembled using the aluminium expansion joint.

Possibility for intelligent control of two opposing automations thanks to "master/slave" function.

**Strength and reliability:** robust structure in steel, new high strength balancing springs guaranteed up to 1,000,000 opening and closing operations and elliptical section bar with high wind-gust resistance.

Optional flashing or traffic light can be integrated in cover.

Encoder movement control and electromechanical limit switches.

**More comfort and safety in programming and maintenance phases:** the separate enclosures for electronics and mechanics protect internal parts from potential risks.

**Rapid and easy access** to the control unit located in the upper section of the barrier body.

Simple fixture of the completely concealed photocells onto the specially designed seats on the barrier body.

**More safety and reliability:** obstacle detection and monitoring of motor absorption during automation movement.

Automatic fault diagnostics during operation with consequent signalling of fault type through specific flash sequences.

Provision for connection of latest generation optical and resistive sensitive edges (with 8.2 KOhm resistance).

**Energy saving:** the system sets to standby when not in use to save consumption.

**No blackouts:** emergency backup power with the optional batteries housed inside the case.

**Release from side with metal key,** can be installed on either side.



### WITH BAR UP TO 3 m, IRREVERSIBLE 230 Vac, 24 Vdc MOTOR, WITH FOUNDATION PLATE:

CODE	DESCRIPTION
M3BAR	WITH STEEL CASE WITH PROTECTIVE CATAPHORESIS TREATMENT AND PAINT FINISH
M3BARI	WITH STAINLESS STEEL CASE

### WITH BAR UP TO 4 OR 5 m, IRREVERSIBLE 230 Vac, 24 Vdc MOTOR, WITH FOUNDATION PLATE:

CODE	DESCRIPTION
M5BAR	WITH STEEL CASE WITH PROTECTIVE CATAPHORESIS TREATMENT AND PAINT FINISH
M5BARI	WITH STAINLESS STEEL CASE

### WITH BAR UP TO 5, 6 OR 7 m, IRREVERSIBLE 230 Vac, 24 Vdc MOTOR, WITH FOUNDATION PLATE:

CODE	DESCRIPTION
M7BAR	WITH STEEL CASE WITH PROTECTIVE CATAPHORESIS TREATMENT AND PAINT FINISH
M7BARI	WITH STAINLESS STEEL CASE

## TECHNICAL SPECIFICATIONS

CODE	M3BAR	M3BARI	M5BAR	M5BARI	M7BAR	M7BARI
<b>ELECTRICAL DATA</b>						
POWER SUPPLY (Vac 50/60 Hz)				230		
POWER SUPPLY (Vdc)				24		
ABSORPTION (A)	1,3		1,1		1,1	
POWER (W)	150		110		110	
<b>PERFORMANCE DATA</b>						
SPEED MIN.=MAX. (S)	1,5 ÷ 4		3 ÷ 6		6 ÷ 10	
TORQUE (Nm)	100		200		300	
WORK CYCLE (CYCLES/HOUR)	500		350		200	
<b>DIMENSIONAL AND GENERAL DATA</b>						
PROTECTION LEVEL (IP)				44		
WORKING TEMP. (°C MIN/MAX)				-20 ÷ +50		
DIMENSIONS (mm)				400x299x1215 h		
WEIGHT (kg)				80		85

## DIMENSIONS

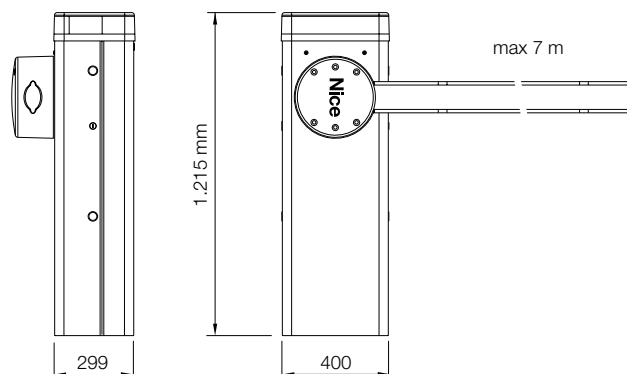

Nice recommends customers order products in order to facilitate storage and delivery, and ensure packs are uniform. The number of packs per single pallet has been specified for this reason. Approximate draft.

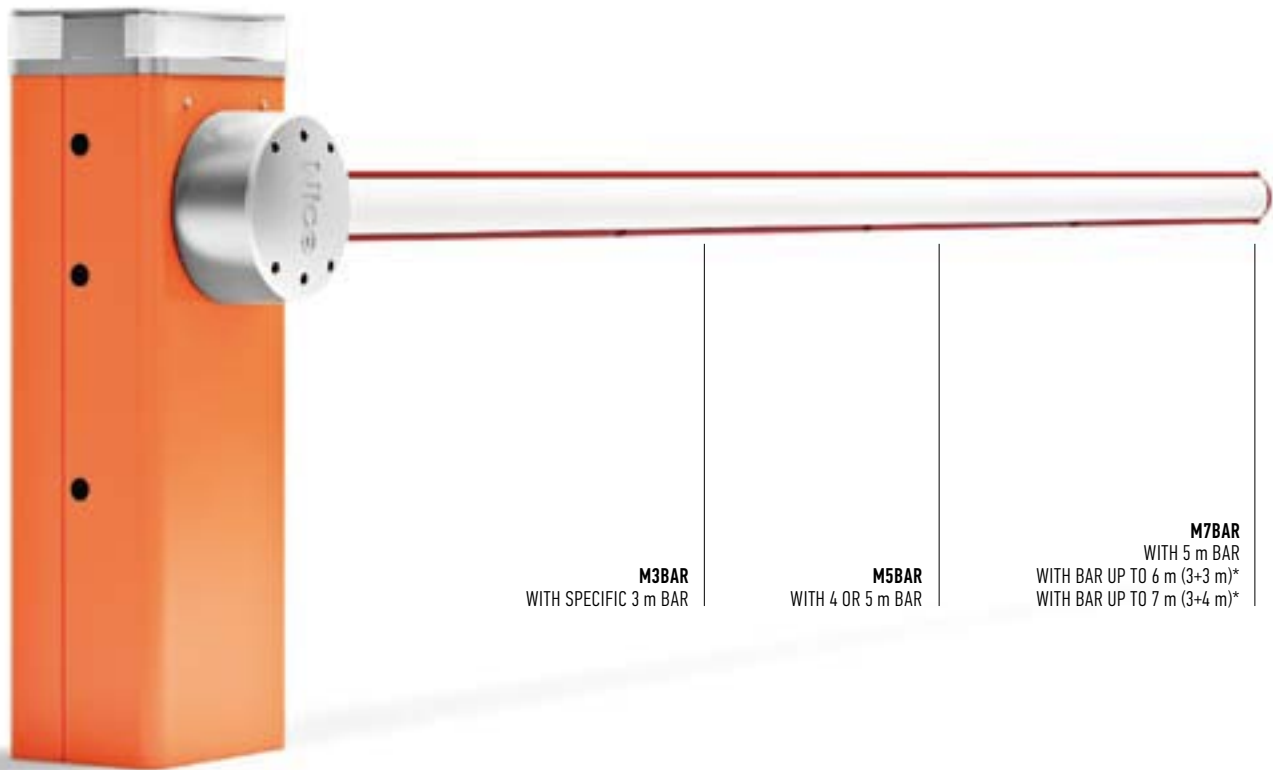

**M3BAR**  
WITH SPECIFIC 3 m BAR

**M5BAR**  
WITH 4 OR 5 m BAR

**M7BAR**  
WITH 5 m BAR  
WITH BAR UP TO 6 m (3+3 m)\*  
WITH BAR UP TO 7 m (3+4 m)\*

\*USE XBA9 JOINT TO ASSEMBLE BARS

**KIT SOLEMYO**



● THE SOLAR POWER KIT SOLEMYO TO AUTOMATE GATES, GARAGE DOORS OR BARRIER GATES, INCLUDING THOSE LOCATED FAR FROM THE POWER MAINS AND WITHOUT THE NEED FOR COSTLY AND INVASIVE EXCAVATION WORK. SEE PAGE 171

**INSTALLATION DIAGRAM**

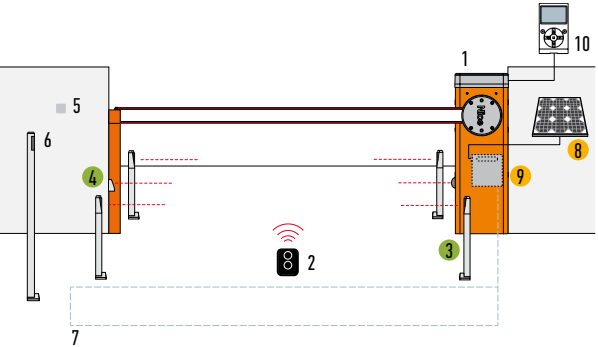

- 1. BARRIER
- 2. TRANSMITTER
- 3. PHOTOCELLS MOUNTED ON POSTS
- 4. PHOTOCELLS
- 5. DIGITAL OR KEY SWITCHES
- 6. KEY-OPERATED SELECTOR OR DIGITAL ON POST
- 7. LOOP DETECTOR
- 8. SYP SOLAR PANEL
- 9. PSY24 BATTERY BOX
- 10. 0-VIEW MULTIFUNCTION DISPLAY

● ACCESSORIES ALSO AVAILABLE FOR THE Solemyo Air Net System WIRELESS VERSION  
● Solemyo SOLAR POWER ACCESSORIES

# ACCESSORIES M-BAR

## ACCESSORIES FOR M3BAR, M5BAR, M7BAR



**XBA3**  
SPARE CONTROL UNIT.  
PC/PACK 1



**PS224**  
24 Vdc BUFFER BATTERY.  
PC/PACK 1



**XBA13**  
RUBBER IMPACT PROTECTION  
STRIP. LENGTH 1 m.  
PC/PACK 9



**WA10**  
RED ADHESIVE  
REFLECTOR STRIPS.  
PC/PACK 24



**XBA8**  
INTEGRABLE TRAFFIC LIGHT.  
PC/PACK 1



**XBA7**  
INTEGRABLE FLASHING LIGHT.  
PC/PACK 1



**XBA16**  
ANCHORAGE BASE WITH  
CLAMPS, FOR M-BAR.  
PC/PACK 1



**WA11**  
ADJUSTABLE STAND  
FOR BARS.  
PC/PACK 1

## ACCESSORIES FOR M3BAR



**XBA15**  
WHITE PAINT-FINISHED  
ALUMINIUM BAR  
69x92x3150 mm.  
PC/PACK 1



**XBA4**  
INDICATOR LIGHTS FOR CLICK  
FIXTURE ON UPPER OR LOWER  
SIDE OF BAR. LENGTH 4 m.  
PC/PACK 1



**XBA10**  
PIVOTING CONNECTION  
FOR BARS UP TO 4 m.  
PC/PACK 1



**XBA11**  
JOINT FOR BARS XBA15  
(FROM 1950 mm  
TO 2400 mm).  
PC/PACK 1

## ACCESSORIES FOR M5BAR



**XBA14**  
WHITE PAINT-FINISHED  
ALUMINIUM BAR  
69x92x4150 mm  
PC/PACK 1



**XBA5**  
WHITE PAINT-FINISHED  
ALUMINIUM BAR  
69x92x5150 mm.  
PC/PACK 1



**XBA4**  
INDICATOR LIGHTS FOR CLICK  
FIXTURE ON UPPER OR LOWER  
SIDE OF BAR. LENGTH 4 m.  
PC/PACK 1



**XBA6**  
INDICATOR LIGHTS FOR CLICK  
FIXTURE ON UPPER OR LOWER  
SIDE OF BAR. LENGTH 6 m.  
PC/PACK 1



**XBA10**  
PIVOTING CONNECTION  
FOR BARS UP TO 4 m.  
PC/PACK 1



**XBA11**  
JOINT FOR BARS XBA15 AND  
XBA14 (FROM 1950 mm  
TO 2400 mm).  
PC/PACK 1



**WA12**  
MOBILE STAND FOR BARS  
- *NEW FULLY REINFORCED  
VERSION.*  
PC/PACK 1



**WA13**  
ALUMINIUM RACK UP TO 2 m.  
PC/PACK 1

## ACCESSORIES FOR M7BAR



**XBA15**  
WHITE PAINT-FINISHED  
ALUMINIUM BAR  
69x92x3150 mm.  
PC/PACK 1



**XBA14**  
WHITE PAINT-FINISHED  
ALUMINIUM BAR  
69x92x4150 mm  
PC/PACK 1



**XBA5**  
WHITE PAINT-FINISHED  
ALUMINIUM BAR  
69x92x5150 mm.  
PC/PACK 1



**XBA9**  
EXPANSION JOINT.  
PC/PACK 1



**XBA6**  
INDICATOR LIGHTS FOR CLICK  
FIXTURE ON UPPER OR LOWER  
SIDE OF BAR. LENGTH 6 m.  
PC/PACK 1



**XBA18**  
INDICATOR LIGHTS FOR CLICK  
FIXTURE ON UPPER OR LOWER  
SIDE OF BAR. LENGTH 8 m.  
PC/PACK 1



**WA12**  
MOBILE STAND FOR BARS  
- *NEW FULLY REINFORCED  
VERSION.*  
PC/PACK 1



**WA13**  
ALUMINIUM RACK UP TO 2 m.  
PC/PACK 1

# L-BAR

SOLEMYO OPERA BLUEBUS 24V

## Electromechanical road barrier system for control of road access.

24 Vdc gear motor with built-in control unit and loop detector.

## Powerful and fast, for bars from 7 to 9 m.

**Modular:** bars are easily assembled using the aluminium expansion joint.

Possibility for intelligent control of two opposing automations thanks to **"master/slave" function**.

**Strength and reliability:** robust structure in steel, new high strength balancing springs guaranteed up to 1,000,000 opening and closing operations and elliptical section bar with high wind-gust resistance.

Optional flashing or traffic light can be integrated in cover.

Encoder movement control and electromechanical limit switches.

**More comfort and safety in programming and maintenance phases:** the separate enclosures for electronics and mechanics protect internal parts from potential risks.

**Rapid and easy access** to the control unit located in the upper section of the barrier body.

Simple fixture of the completely concealed photocells onto the specially designed seats on the barrier body.

**More safety and reliability:** obstacle detection and monitoring of motor absorption during automation movement.

Automatic fault diagnostics during operation with consequent signalling of fault type through specific flash sequences.

Provision for connection of latest generation optical and resistive sensitive edges (with 8.2 KOhm resistance).

**Energy saving:** the system sets to standby when not in use to save consumption.

**No blackouts:** emergency backup power with the optional batteries housed inside the case.

**Release from side with metal key,** can be installed on either side.



## FOR BARS UP TO 9 m, IRREVERSIBLE 230 Vac, 24 Vdc MOTOR, WITH FOUNDATION PLATE:

CODE	DESCRIPTION
LBAR	WITH STEEL CASE WITH PROTECTIVE CATAPHORESIS TREATMENT AND PAINT FINISH
LBARI	WITH STAINLESS STEEL CASE

## TECHNICAL SPECIFICATIONS

CODE	LBAR	LBARI
<b>ELECTRICAL DATA</b>		
POWER SUPPLY (Vac 50/60 Hz)		230
ABSORPTION (A)		1.3
POWER (W)		160
<b>PERFORMANCE DATA</b>		
SPEED MIN.=MAX. (S)		8 ÷ 12
TORQUE (Nm)		400
WORK CYCLE (CYCLES/HOUR)		150
<b>DIMENSIONAL AND GENERAL DATA</b>		
PROTECTION LEVEL (IP)		44
WORKING TEMP. (°C MIN/MAX)		-20 ÷ +50
DIMENSIONS (mm)		500x299x1215 h
WEIGHT (kg)		98

## DIMENSIONS

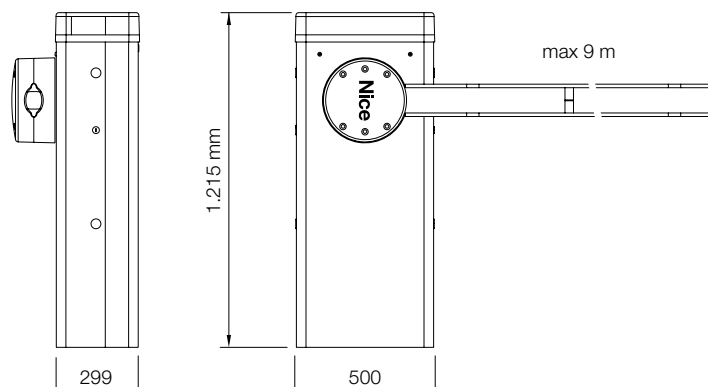

## ACCESSORIES

## KIT SOLEMYO



**XBA3**  
SPARE CONTROL UNIT.  
PC/PACK 1



**PS224**  
24 Vdc BUFFER BATTER.  
PC/PACK 1



**XBA15**  
WHITE PAINT-FINISHED  
ALUMINIUM BAR  
69x92x3150 mm.  
PC/PACK 1



**XBA14**  
WHITE PAINT-FINISHED  
ALUMINIUM BAR  
69x92x4150 mm.  
PC/PACK 1



**XBA5**  
WHITE PAINT-FINISHED  
ALUMINIUM BAR  
69x92x5150 mm.  
PC/PACK 1



**XBA9**  
EXPANSION JOINT.  
PC/PACK 1



**XBA13**  
RUBBER IMPACT PROTECTION  
STRIP. LENGTH 1 m.  
PC/PACK 9



**WA10**  
RED ADHESIVE  
REFLECTOR STRIPS.  
PC/PACK 24



● THE SOLAR POWER  
KIT SOLEMYO TO AUTOMATE  
GATES, GARAGE DOORS  
OR BARRIER GATES,  
INCLUDING THOSE LOCATED  
FAR FROM THE POWER MAINS  
AND WITHOUT THE NEED  
FOR COSTLY AND INVASIVE  
EXCAVATION WORK.  
SEE PAGE 171



**XBA18**  
INDICATOR LIGHTS FOR CLICK  
FIXTURE ON UPPER OR LOWER  
SIDE OF BAR. LENGTH 8 m.  
PC/PACK 1



**XBA8**  
INTEGRABLE TRAFFIC LIGHT.  
PC/PACK 1



**XBA7**  
INTEGRABLE FLASHING LIGHT.  
PC/PACK 1



**WA13**  
ALUMINIUM RACK UP TO 2 m.  
PC/PACK 1



**XBA17**  
ANCHORAGE BASE WITH  
CLAMPS, FOR LBAR.  
PC/PACK 1



**WA12**  
MOBILE STAND FOR BARS  
- NEW FULLY REINFORCED  
VERSION.  
PC/PACK 1



**WA11**  
ADJUSTABLE STAND  
FOR BARS.  
PC/PACK 1

## INSTALLATION DIAGRAM

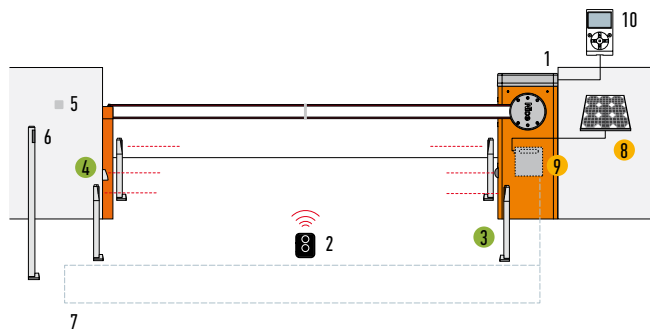

1. BARRIER
2. TRANSMITTER
3. PHOTOCELLS MOUNTED ON POSTS
4. PHOTOCELLS
5. DIGITAL OR KEY SWITCHES
6. KEY-OPERATED SELECTOR OR DIGITAL ON POST
7. LOOP DETECTOR
8. SYP SOLAR PANEL
9. PSY24 BATTERY BOX
10. 0-VIEW MULTIFUNCTION DISPLAY

- ACCESSORIES ALSO AVAILABLE FOR THE Solemyo Air Net System WIRELESS VERSION
- Solemyo SOLAR POWER ACCESSORIES

Nice recommends customers order products in pallets in order to facilitate storage and delivery, and ensure packs are uniform. The number of packs per single pallet has been specified for this reason. Approximate draft.

# SELECTION GUIDE

Irreversible,  
with built-in control unit  
and magnetic encoder.  
**SIGNO**  
pages 106/109

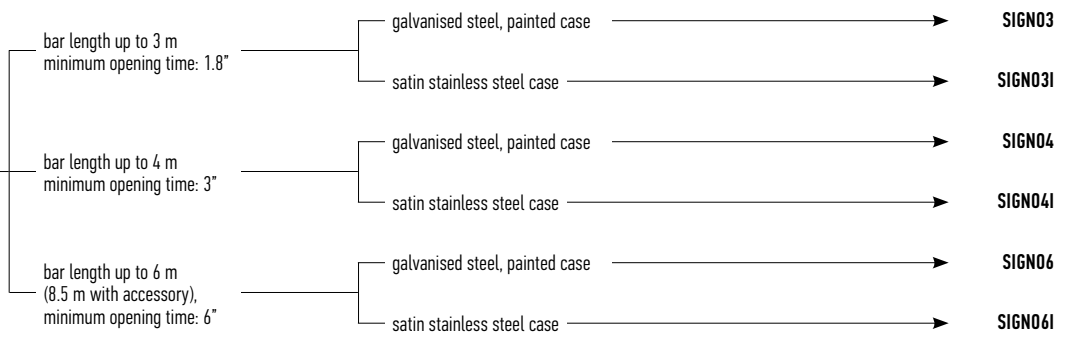



Irreversible,  
with built-in control unit.  
**WIL**  
pages 110/113

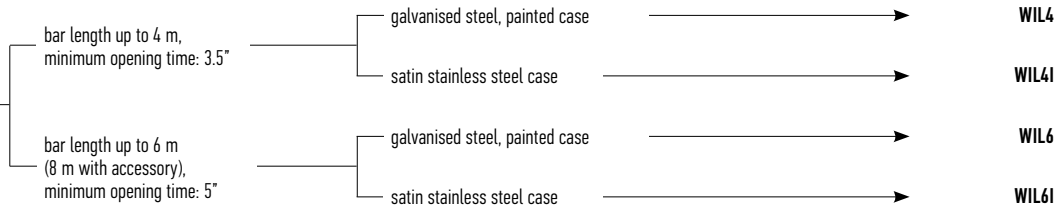

# SIGNO

24V

**For private, public and industrial car parks.**  
Electromechanical barrier gate operator with encoder.

**Powerful and quick:** electromechanical 24 Vdc gear motor, 500 W power and up to 250 Nm torque.

It opens up completely (90°) in just 1.8" (Signo3), 3" (Signo4), 6" (Signo6).

Models with a 230 Vac or 110 Vac power supply.

**Even more sophisticated and well-developed control unit:**

The same for all models, it automatically recognises and memorises the Signo model on which it is installed thereby eliminating the first installation procedure.

Signals that the power supply is correct when started and that the control unit is functioning correctly.

Automatic diagnostics during operation, with differentiated visual signals according to the type of fault.

**Intelligent:** the manoeuvre will invert automatically if the bar comes into contact with an obstacle.

The control unit automatically corrects any eventual lack of balance linked to variations in the climate or poor installation.

**Safe:** the innovative control unit utilises a revolutionary management system of the force, speed, acceleration and deceleration that can be **programmed at 6 levels**, at the beginning and at the end of the manoeuvre. Programming is intuitive and automatic with the Nice Encoder technology: simply push a button and Signo will comprehend the limit switch limits.

**Large openings:** a master/slave selection automatically synchronises two opposing barriers enabling the automation of transit points up to 8 and 12 m.

**Convenient:** separate compartments for electronics and mechanics provide the user with easy access without damages to internal parts.

**Exclusive functions:**

- the barrier will close immediately after the vehicle has passed through;
- it has two types of traffic-light type signals;
- there is an automatic safety test at the beginning of each manoeuvre;
- constant resistance STOP input for connecting the latest generation of sensitive edges;
- there is a manoeuvre counter and it is possible to programme the maintenance alarm threshold.

**Intensive use for long periods of time:**

Ideal for automating private, public or industrial car-parks which are subjected to the frequent passage of vehicles during the day.

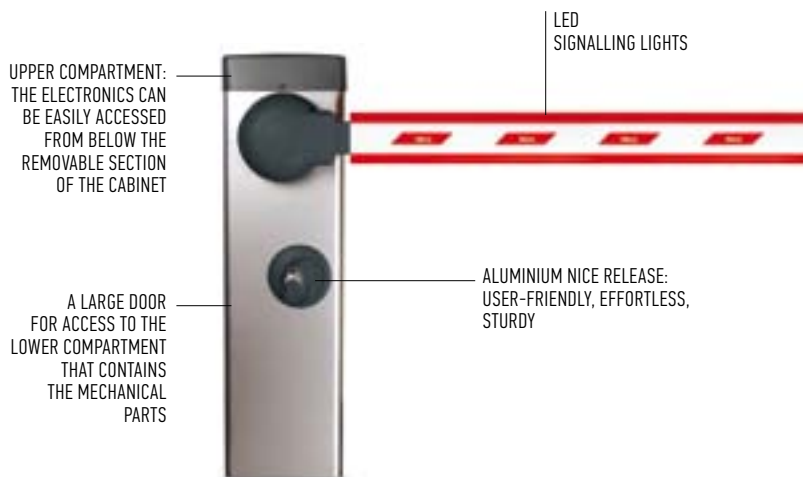

## IRREVERSIBLE 230 Vac, 24 Vdc MOTOR, WITH ANCHORAGE BASE INCLUDED:

CODE	DESCRIPTION
<b>SIGN03</b>	FOR BARS UP TO 3 m, WITH GALVANISED STEEL PAINTED CASE
<b>SIGN03I</b>	FOR BARS UP TO 3 m, WITH SATIN STAINLESS STEEL CASE
<b>SIGN04</b>	FOR BARS UP TO 4 m, WITH GALVANISED STEEL PAINTED CASE
<b>SIGN04I</b>	FOR BARS UP TO 4 m, WITH SATIN STAINLESS STEEL CASE
<b>SIGN06</b>	FOR BARS UP TO 6 m, WITH GALVANISED STEEL PAINTED CASE
<b>SIGN06I</b>	FOR BARS UP TO 6 m, WITH SATIN STAINLESS STEEL CASE

## TECHNICAL SPECIFICATIONS

CODE	SIGN03 - SIGN03I	SIGN04 - SIGN04I	SIGN06 - SIGN06I
<b>ELECTRICAL DATA</b>			
POWER SUPPLY (Vac 50/60 Hz)	230		
ABSORPTION (A)	1.1	1.3	1.3
POWER (W)	300	300	500
<b>PERFORMANCE DATA</b>			
MIN.=MAX. OPENING TIME (S)	1.8÷4	3÷6	6÷10
TORQUE (Nm)	130	200	250
WORK CYCLE (CYCLES/HOUR)	600	400	250
<b>DIMENSIONAL AND GENERAL DATA</b>			
PROTECTION LEVEL (IP)	44		
WORKING TEMP. (°C MIN/MAX)	-20 ÷ +50		
DIMENSIONS (mm)	320x200x1070 h		420x220x1070 h
WEIGHT (kg)	50		58

## DIMENSIONS

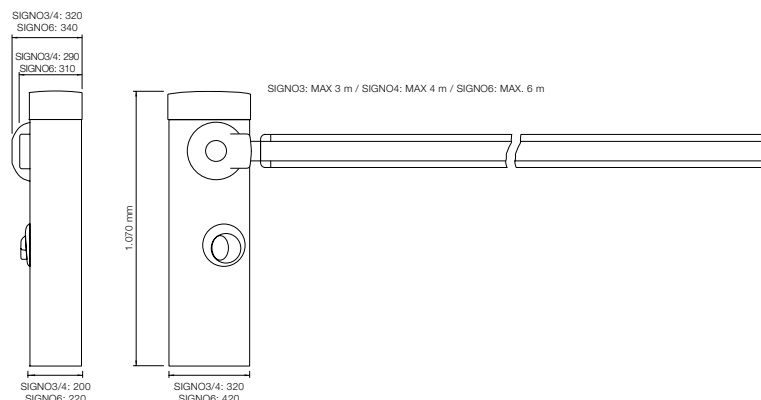

## UTILISATION LIMITS

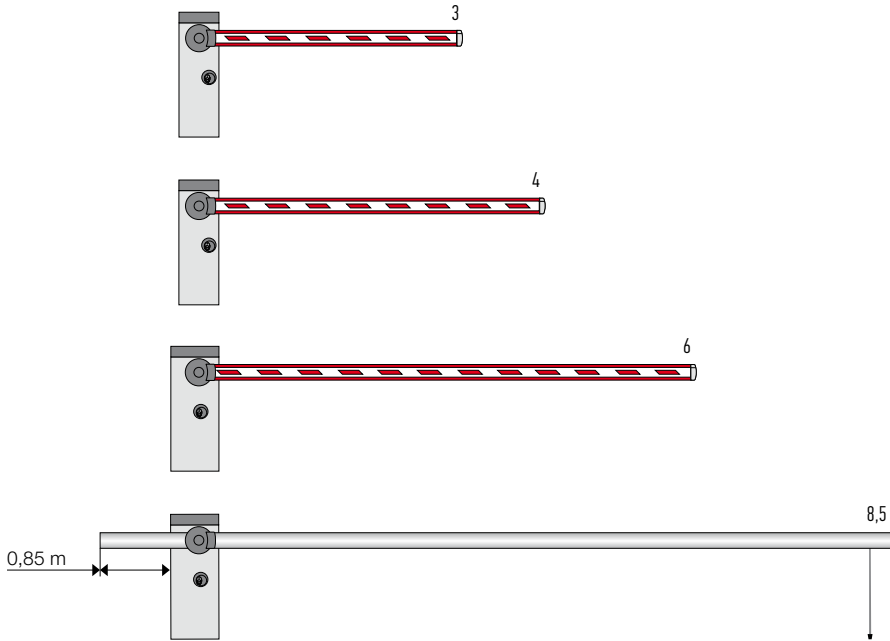

**SIGN03 / SIGN03I up to 3 m**  
FULLY ACCESSORIED BAR WITHOUT RACK AND MOBILE STANDS, WITH LIMITS TO SPEED.

**SIGN04 / SIGN04I up to 4 m**  
FULLY ACCESSORIED BAR UP TO 3.75 m.

**SIGN06 / SIGN06I up to 6 m**  
BAR WITH COMPLETE SET OF ACCESSORIES WITH LIMITS TO SPEED.

**SIGN06 / SIGN06I up to 8.5 m**  
WITH WA24 (BAR) WITHOUT ACCESSORIES, EQUIPPED WITH MOBILE STAND, WITH LIMITS TO SPEED.

### Bar lenght (m)

Tubular aluminium bars don't need the use of accessories (only WA11).

## INSTALLATION DIAGRAM

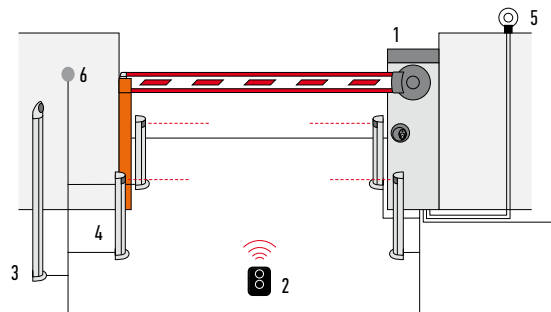

1. SIGNO
2. TRANSMITTER
3. KEY-OPERATED SELECTOR ON POST
4. PHOTOCCELLS MOUNTED ON POSTS
5. FLASHING LIGHT
6. DIGITAL OR KEY SWITCHES.

# ACCESSORIES SIGNO

## ACCESSORIES FOR SIGNO3 / SIGNO3I



**SIA3**  
ALUMINIUM BAR, PAINTED  
WHITE 36X73X3250 mm.  
PC/PACK 1



**WA25**  
PIVOTING CONNECTION  
FOR RECTANGULAR BARS  
UP TO 4 m.  
PC/PACK 1



**WA2**  
8 m PACK OF RED  
SHOCKPROOF RUBBER STRIP  
WITH CAPS TO CLOSE  
SIA3 BAR.  
PC/PACK 1



**SIA1**  
ANCHORAGE BASE  
WITH CLAMPS.  
PC/PACK 1

## ACCESSORIES FOR SIGNO4 / SIGNO4I



**WA1**  
ALUMINIUM BAR, PAINTED  
WHITE 36X73X4250 mm.  
PC/PACK 1



**WA25**  
PIVOTING CONNECTION  
FOR RECTANGULAR BARS  
UP TO 4 m.  
PC/PACK 1



**WA2**  
8 m PACK OF RED  
SHOCKPROOF RUBBER  
STRIP WITH CAPS  
TO CLOSE WA1 BAR.  
PC/PACK 1



**WA13**  
ALUMINIUM RACK (2 m)  
FOR WA1, WA21, WA22 BARS.  
PC/PACK 1



**WA14**  
JOINT FOR RODS WA1  
(FROM 1950 mm  
TO 2400 mm).  
PC/PACK 1



**WA3**  
TUBULAR ALUMINIUM BAR,  
PAINTED WHITE  
Ø 70X4250 mm, SUITABLE  
WHERE THERE ARE STRONG  
WINDS. ONLY WITH WA11.  
PC/PACK 1



**WA4**  
CONNECTION  
FOR THE WA3 BAR.  
PC/PACK 1



**SIA1**  
ANCHORAGE BASE  
WITH CLAMPS.  
PC/PACK 1

### ACCESSORIES FOR SIGNO6 / SIGNO6I



**WA21**  
ALUMINIUM BAR, PAINTED  
WHITE 36X94X6250 mm.  
PC/PACK 1



**WA22**  
MODULAR BAR, PLUS JOINT  
PAINTED WHITE, 2 SECTIONS  
36X94X3125 mm.  
PC/PACK 2



**WA6**  
PACK 12 m OF RED  
SHOCKPROOF RUBBER STRIP  
WITH CAPS TO CLOSE  
THE BARS WA21, WA22.  
PC/PACK 1



**WA24**  
TUBULAR TELESCOPIC  
BAR IN WHITE PAINTED  
ALUMINIUM, MAX. LENGTH  
8.5 m, COMPLETE WITH  
MOBILE SUPPORT WA12,  
COUNTERWEIGHT AND  
CONNECTOR. 6 METERS  
OVERALL LENGTH FOR  
TRANSPORTATION.  
See draft page 107.  
PC/PACK 1



**WA7**  
TUBULAR ALUMINIUM BAR,  
PAINTED WHITE  
Ø 90X6250 mm SUITABLE  
WHERE THERE ARE STRONG  
WINDS, ONLY WITH WA11.  
PC/PACK 1



**WA13**  
ALUMINIUM RACK (2 m)  
FOR WA1, WA21, WA22 BARS.  
PC/PACK 1



**SIA2**  
ANCHORAGE BASE  
WITH CLAMPS.  
PC/PACK 1



**WA8**  
CONNECTION  
FOR THE WA7 BAR.  
PC/PACK 1

### COMMON ACCESSORIES FOR SIGNO SERIES



**SIA20**  
SPARE CONTROL UNIT.



**PS224**  
24 Vdc BUFFER BATTERY.  
PC/PACK 1



**WA9**  
PACK OF 6 FLASHING  
SIGNALS, WIRED FOR WA1,  
WA21, WA22 BARS.  
PC/PACK 6



**WA10**  
RED ADHESIVE  
REFLECTOR STRIPS.  
PC/PACK 24



**WA11**  
ADJUSTABLE STAND  
FOR BARS.  
PC/PACK 1



**WA12**  
MOBILE STAND FOR BARS  
- NEW FULLY REINFORCED  
VERSION.  
PC/PACK 1



**PO**  
SUPPORT BRACKET  
FOR PHOTOCELLS MOF  
AND MOFB.  
PC/PACK 4

# WIL

24V

### For private, public and industrial car parks.

Electromechanical barrier gate, 24 Vdc, with adjustable speed and anti-crushing safety feature. Intensive use.

#### Four versions:

up to 4 m (WIL4, WIL4I),

up to 6 m (WIL6, WIL6I).

Galvanised steel, painted case or AISI 304 (WIL4I, WIL6I).

Incorporated control unit, can be removed, making wiring and maintenance easier.

Easy to install: the bar can be assembled on either the right or left hand side indifferently.

#### Easy to balance:

linear adjustment of the spring.

The system will operate during a blackout by means of internally fitted, rechargeable batteries.

The limit switches for slowdown during both opening and closing can be adjusted both mechanically and electronically.

#### Speed can be electronically adjusted:

WIL4, 3.5 second minimum opening time;

WIL6, 5 second opening time.

#### Anti-crush safety feature

on opening and closing.

#### Painted aluminium bar profile:

easy to assemble the signalling lights and pneumatic edge.

#### LED signalling lights:

highly efficient and long-lasting.

#### Protected simple key-operated release.



#### IRREVERSIBLE 230 Vac, 24 Vdc MOTOR, WITH ANCHORAGE BASE INCLUDED:

CODE	DESCRIPTION
WIL4	FOR BARS UP TO 4 m, WITH GALVANISED STEEL PAINTED CASE
WIL4I	FOR BARS UP TO 4 m, WITH SATIN STAINLESS STEEL CASE
WIL6	FOR BARS UP TO 6 m, WITH GALVANISED STEEL PAINTED CASE
WIL6I	FOR BARS UP TO 6 m, WITH SATIN STAINLESS STEEL CASE

#### TECHNICAL SPECIFICATIONS

CODE	WIL4 - WIL4I	WIL6 - WIL6I
<b>ELECTRICAL DATA</b>		
POWER SUPPLY (Vac 50/60 Hz)	230	
ABSORPTION (A)	1.1	0.6
POWER (W)	300	360
<b>PERFORMANCE DATA</b>		
MINIMUM OPENING TIME (S)	3.5	5
TORQUE (Nm)	140	200
WORK CYCLE (%)	80	
<b>DIMENSIONAL AND GENERAL DATA</b>		
PROTECTION LEVEL (IP)	54	
WORKING TEMP. (°C MIN/MAX)	-20 ÷ +50	
DIMENSIONS (mm)	320x220x1000 h	420x220x1050 h
WEIGHT (kg)	46	54

#### DIMENSIONS

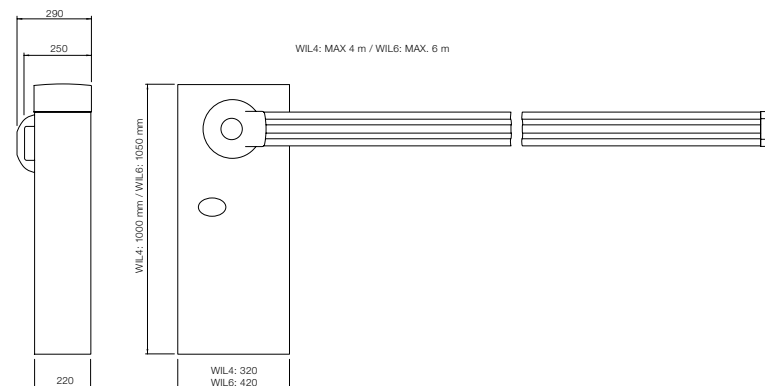

## UTILISATION LIMITS

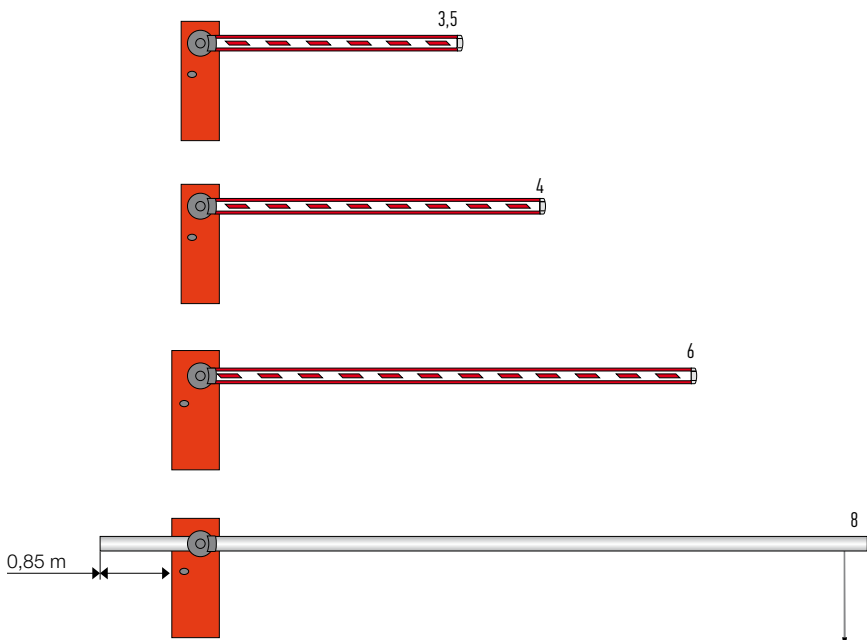

**WIL4 / WIL4I up to 3.5 m**  
FULLY ACCESSORIED BAR  
WITHOUT SPEED LIMIT.

**WIL4 / WIL4I up to 4 m**  
FULLY ACCESSORIED BAR WITH SPEED LIMIT  
AND A WA13 RACK MAX LENGHT OF 2 m  
**or**  
4 m RACK LENGHT WITHOUT SHOCKPROOF  
RUBBER STRIP WA2.

**WIL6 / WIL6I up to 6 m**  
FULLY ACCESSORIED BAR WITH SPEED LIMIT  
AND A WA13 RACK MAX LENGHT OF 4 m  
**or**  
WA13 RACK LENGHT 6 m,  
WITHOUT SHOCKPROOF RUBBER STRIP WA2.

**WIL6 / WIL6I up to 8 m**  
WITH WA24 (BAR WITHOUT ACCESSORIES),  
WITH NO LIMITS TO SPEED.

### Bar lenght (m)

Tubular aluminium bars don't need the use of accessories (only WA11).

## INSTALLATION DIAGRAM

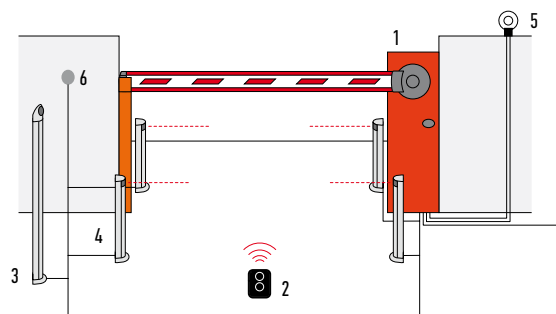

1. WIL
2. TRANSMITTER
3. SELECTOR KEY-OPERATED ON POST
4. PHOTOCELLS MOUNTED ON POSTS
5. FLASHING LIGHT
6. DIGITAL OR KEY SWITCHES.

# ACCESSORIES WIL

## ACCESSORIES FOR WIL4 / WIL4I



**WA1**  
ALUMINIUM BAR, PAINTED  
WHITE 36X73X4250 mm.  
PC/PACK 1



**WA25**  
PIVOTING CONNECTION  
FOR RECTANGULAR BARS  
UP TO 4 m.  
PC/PACK 1



**WA2**  
8 m PACK OF RED  
SHOCKPROOF RUBBER STRIP  
WITH CAPS TO CLOSE  
WA1 BAR.  
PC/PACK 1



**WA14**  
JOINT FOR RODS WA1  
(FROM 1950 mm  
TO 2400 mm).  
PC/PACK 1



**WA3**  
TUBULAR ALUMINIUM BAR,  
PAINTED WHITE  
Ø 70X4250 mm, SUITABLE  
WHERE THERE ARE STRONG  
WINDS ONLY WITH WA11.  
PC/PACK 1



**WA4**  
CONNECTION  
FOR THE WA3 BAR.  
PC/PACK 1



**WA15**  
ANCHORAGE BASE  
WITH CLAMPS.  
PC/PACK 1

## ACCESSORIES FOR WIL6 / WIL6I



**WA21**  
ALUMINIUM BAR,  
PAINTED WHITE  
36X94X6250 mm.  
PC/PACK 1



**WA22**  
MODULAR BAR, PLUS JOINT  
PAINTED WHITE, 2 SECTIONS  
36X94X3125 mm.  
PC/PACK 2



**WA6**  
PACK 12 m OF RED,  
SHOCKPROOF, RUBBER STRIP  
WITH CAPS TO CLOSE  
THE BARS WA21, WA22.  
PC/PACK 1



**WA24**  
TUBULAR TELESCOPIC BAR IN  
WHITE PAINTED ALUMINIUM,  
MAX. LENGTH 8 m, COMPLETE  
WITH MOBILE SUPPORT WA12,  
COUNTERWEIGHT  
AND CONNECTOR.  
6 m OVERALL LENGTH  
FOR TRANSPORTATION.  
See draft page 111.  
PC/PACK 1



**WA7**  
TUBULAR ALUMINIUM BAR,  
PAINTED WHITE  
Ø 90X6250 mm SUITABLE  
WHERE THERE ARE STRONG  
WINDS, ONLY WITH WA11.  
PC/PACK 1



**WA8**  
CONNECTION  
FOR THE WA7 BAR.  
PC/PACK 1



**WA16**  
ANCHORAGE BASE  
WITH CLAMPS.  
PC/PACK 1



## COMMON ACCESSORIES FOR WIL SERIES



**WA20**  
SPARE CONTROL UNIT.



**CARICA**  
PLUG-IN CARD  
FOR BATTERY CHARGER.  
PC/PACK 1



**B12-B**  
12 V, 6 Ah BATTERIES.  
PC/PACK 1



**WA9**  
PACK OF FLASHING SIGNALS,  
WIRED FOR WA1, WA21, WA22  
BARS.  
PC/PACK 6



**WA10**  
RED ADHESIVE  
REFLECTOR STRIPS.  
PC/PACK 24



**WA13**  
ALUMINIUM RACK (2 m)  
FOR WA1, WA21, WA22 BARS.  
PC/PACK 1



**WA11**  
ADJUSTABLE STAND  
FOR BARS.  
PC/PACK 1



**WA12**  
MOBILE STAND FOR BARS  
- *NEW FULLY REINFORCED  
VERSION.*  
PC/PACK 1



**PO**  
SUPPORT BRACKET  
FOR PHOTOCELLS  
MOF AND MOFB.  
PC/PACK 4



# SYSTEMS FOR GARAGE AND INDUSTRIAL



FOR SECTIONAL AND UP-AND-OVER DOORS	118	SPINBUS
	122	SPINBUSKIT 20/21/22
	124	SPINBUSKIT 23
	126	SPINKIT

---

FOR UP-AND-OVER AND ARTICULATED DOORS	128	TEN
	130	TENKIT

---

FOR SECTIONAL DOORS	132	SOON
	134	SUMO

---

FOR FOLDING 2-LEAF DOORS	136	HYPP0 7100
--------------------------	-----	------------

---

FOR BALANCED ROLLING DOORS	138	RONDO
----------------------------	-----	-------

# SELECTION GUIDE

## FOR SECTIONAL AND UP-AND-OVER DOORS, ALSO AVAILABLE IN KIT

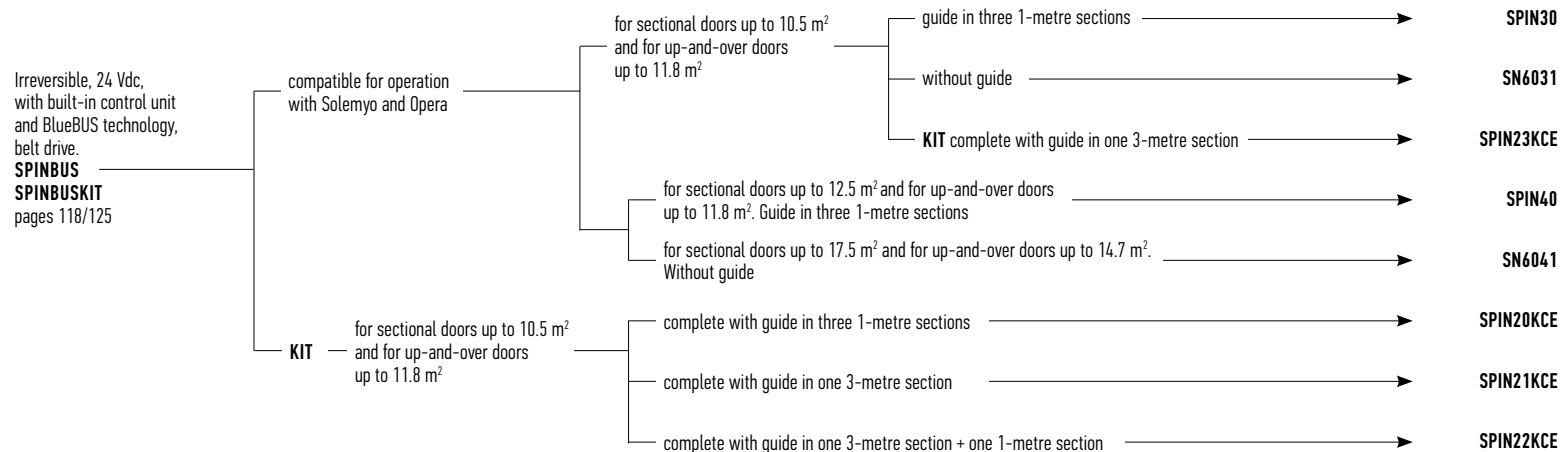

## FOR SECTIONAL AND UP-AND-OVER DOORS, IN KIT

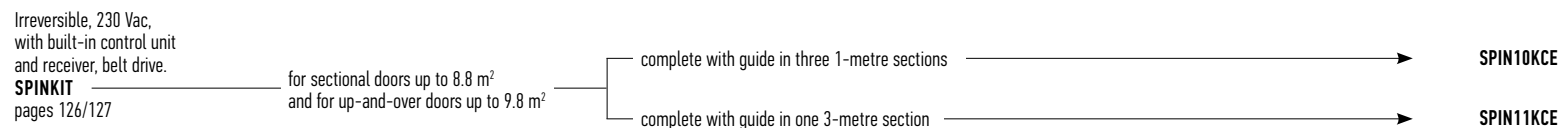

## FOR UP-AND-OVER DOORS, ALSO AVAILABLE IN KIT

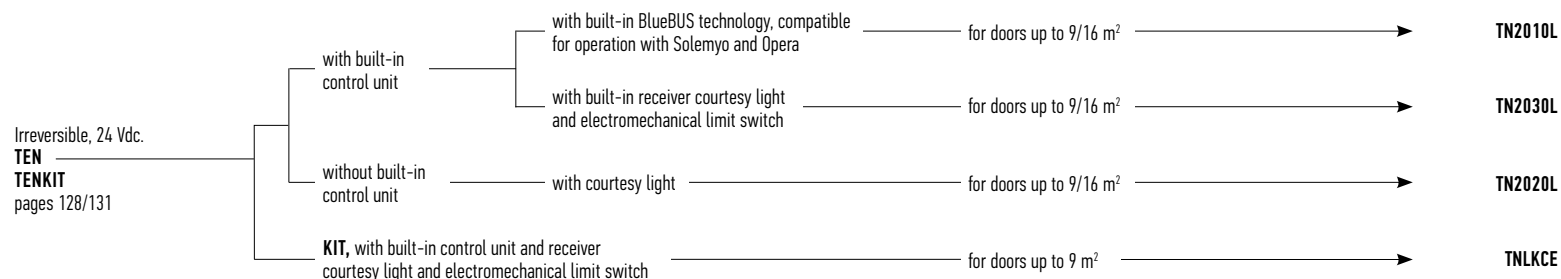

## FOR SECTIONAL DOORS, IDEAL FOR INDUSTRIAL AND COMMERCIAL USE

Irreversible with built-in control unit  
24 Vdc motor, with absolute encoder  
and incorporated BlueBUS technology.  
Compatible for operation  
with Solemyo and Opera.

**SOON** for doors up to 20 m<sup>2</sup>  
pages 132/133

**SO2000**



## FOR SECTIONAL AND SLIDING 2-LEAF DOORS FOR INDUSTRIAL AND COMMERCIAL USE

Irreversible, 24 Vdc motor,  
with magnetic encoder,  
with no need for limit switch  
adjustment.

**SUMO**  
pages 134/135

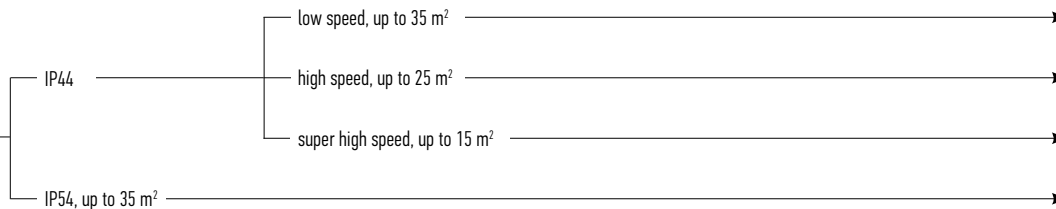

**SU2000**

**SU2000V**

**SU2000VV**

**SU2010**



## FOR FOLDING 2-LEAF DOORS

Irreversible  
with telescopic arm.

**HYPPO**  
pages 136/137

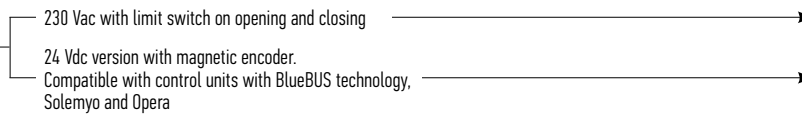

**HY7100**

**HY7124**



## FOR BALANCED ROLLING DOORS

230 Vac,  
with electromechanical  
limit switch.

**RONDO**  
pages 138/139

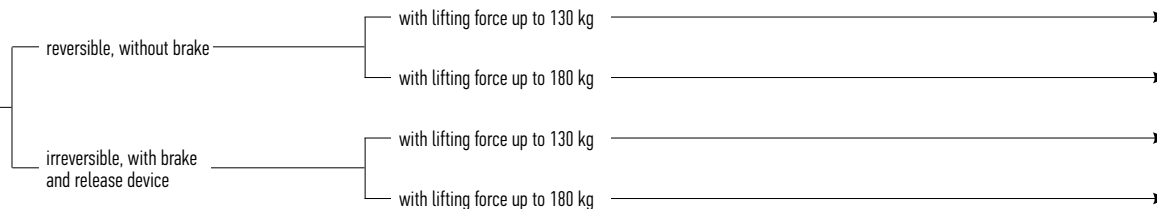

**RN2010**

**RN2020**

**RN2030**

**RN2040**



# SPINBUS

SOLEMYO OPERA BLUEBUS 24V

**For sectional doors up to 12.5 m<sup>2</sup> and up-and-over garage doors up to 11.8 m<sup>2</sup>.** Irreversible electromechanical gear motor, for residential use, with belt drive, 24 Vdc motor, with magnetic encoder.

**Complete version of the guide in 3x1 m sections.**

**Rapid installation - anywhere!**

The adjustable head, cord-type release and cable-controlled, step-by-step release can be fitted in any part of the garage in order to actuate the system without a remote control device and without the need to install wall-mounted control units!

THREE-SECTION GUIDE  
IN GALVANISED STEEL  
WITH BELT DRIVE SYSTEM,  
VERY QUIET



BY ROTATING THE "PETAL"  
WHICH DIFFUSES THE LIGHT (40 W!),  
USERS ACCESS THE INCORPORATED  
BLUEBUS CONTROL UNIT

## Guaranteed savings and respect for the environment:

with the connection to the mains in standby mode the control unit with radio connected consumes just 0.8 W (SPIN30) and 1.2 W (SPIN40); when connected to a battery or to the Solemyo kit, consumption in standby mode is reduced to 0.036 W.

## User-friendly thanks to the BlueBUS system:

which enables connection by means of just two wires between the control unit and pair of photocells.

**Safe:** obstacle detection system and automatic programming of the working times; motor absorption is monitored during movement, self-diagnosis by means of a flashing light and courtesy light.

Acceleration and deceleration can be adjusted at the beginning and end of each opening and closing manoeuvre.

Can be connected with latest generation sensitive edges 8.2 KOhm.

**Luminous:** 40 W lamp that can be used as garage lightning.

CODE	DESCRIPTION	PACK/PALLET
SPIN30	IRREVERSIBLE, 230 Vac, 24 Vdc MOTOR, WITH INCORPORATED CONTROL UNIT, 800 N. COMPLETE WITH GUIDE IN THREE 1 m-SECTIONS	15
SPIN40	IRREVERSIBLE, 230 Vac, 24 Vdc MOTOR, WITH INCORPORATED CONTROL UNIT, 1000 N. COMPLETE WITH GUIDE IN THREE 1 m-SECTIONS	15

## TECHNICAL SPECIFICATIONS

CODE	SPIN30	SPIN40
<b>ELECTRICAL DATA</b>		
POWER SUPPLY (Vac 50/60 Hz)	230	
ABSORPTION (A)	1.3	1.4
POWER (W)	350	370
<b>PERFORMANCE DATA</b>		
SPEED (m/s)	0.20	
FORCE (N)	800	1000
WORK CYCLE (CYCLES/DAY)	50	
<b>DIMENSIONAL AND GENERAL DATA</b>		
PROTECTION LEVEL (IP)	40	
WORKING TEMP. (°C MIN/MAX)	-20 ÷ +50	
DIMENSIONS (mm)	311x327x105 h	
WEIGHT (kg)	3.6	4.7

## UTILISATION LIMITS

Using the maximum travel

	NON-PROJECTING UP-AND-OVER DOOR		PROJECTING UP-AND-OVER DOOR		SECTIONAL	
	H	L	H	L	H	L
SPIN30	2.2 m	4.2 m	2.8 m	4.2 m	2.4 m	5 m
SPIN40	2.2 m	4.2 m	2.8 m	4.2 m	2.4 m	5.2 m

## DIMENSIONS

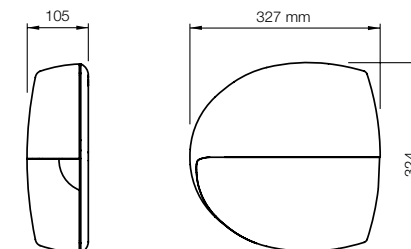



**SNA3**  
SPARE CONTROL UNIT  
FOR SPIN30/SN6031.



**SNA4**  
SPARE CONTROL UNIT  
FOR SPIN40/SN6041.



**PS124**  
24 V BATTERY  
WITH INTEGRATED  
BATTERY CHARGER.  
PC/PACK 1



**SPA2**  
KIT FOR UNLOCKING FROM  
THE OUTSIDE WITH CABLE.  
PC/PACK 1



**SPA5**  
OSCILLATING ARM SLIDING  
ON BEARINGS WITH OPTIMISED  
STRUCTURE FOR PROJECTING  
UP-AND-OVER DOORS.  
PC/PACK 1



**SPA6**  
LARGE 585 mm LONG  
CONNECTING ARM.  
PC/PACK 1



**SPA7**  
KIT OF TWO ADDITIONAL  
FIXING BRACKETS.  
PC/PACK 2



**SNA16**  
QUICK-CONNECT BRACKETS  
FOR CEILING MOUNTING.  
PC/PACK 10



● THE SOLAR POWER  
KIT SOLEMYO TO AUTOMATE  
GATES, GARAGE DOORS  
OR BARRIER GATES,  
INCLUDING THOSE LOCATED  
FAR FROM THE POWER MAINS  
AND WITHOUT THE NEED  
FOR COSTLY AND INVASIVE  
EXCAVATION WORK.  
SEE PAGE 171



**TS**  
SIGNBOARD.

PC/PACK 1

INSTALLATION DIAGRAM

Sectional

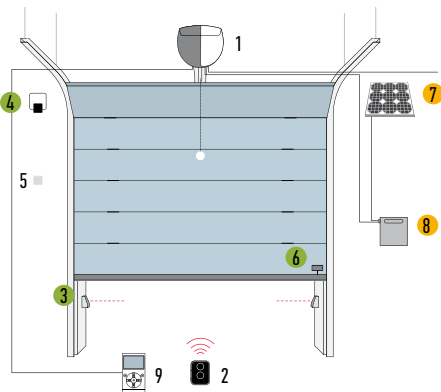

Non-projecting up-and-over door

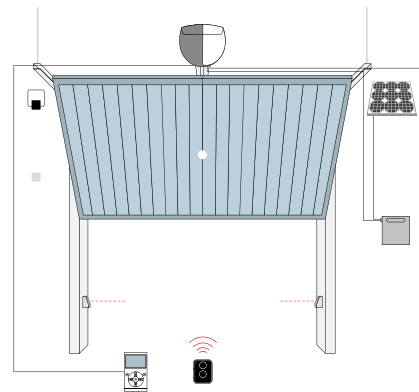

Projecting up-and-over door

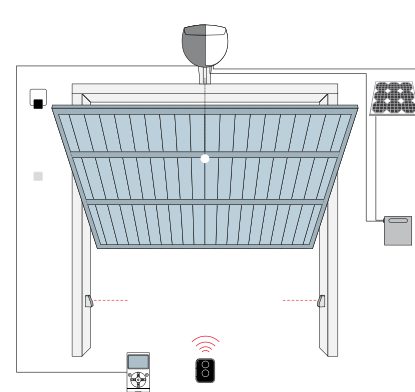

1. MOTOR
2. TRANSMITTER
3. PHOTOCELLS
4. FLASHING LIGHT
5. DIGITAL OR KEY SWITCHES
6. SENSOR FOR SENSITIVE EDGES
7. SYP SOLAR PANEL
8. PSY24 BATTERY BOX
9. 0-VIEW MULTIFUNCTION DISPLAY

- ACCESSORIES ALSO AVAILABLE FOR THE Solemyo Air Net System WIRELESS VERSION
- Solemyo SOLAR POWER ACCESSORIES

Nice recommends customers order products in pallets in order to facilitate storage and delivery, and ensure packs are uniform. The number of packs per single pallet has been specified for this reason. Approximate draft.

# SPINBUS

SOLEMYO OPERA BLUEBUS 24V

**For sectional doors up to 17.5 m<sup>2</sup> and up-and-over garage doors up to 14.7 m<sup>2</sup>.** 230 Vac irreversible electromechanical gear motor, for residential use, with belt drive, 24 Vdc motor, with magnetic encoder.

**To use with the SNA30 - SNA31 guides.**

**Rapid installation - anywhere!**

The adjustable head, cord-type release and cable-controlled, step-by-step release can be fitted in any part of the garage in order to actuate the system without a remote control device and without the need to install wall-mounted control units!

**Guaranteed savings and respect for the environment:** when connected to the mains on standby the control unit with radio connected consumes just 0.8 W (SN6031) and 1.2 W (SN6041); when connected to a battery or to the Solemyo kit, consumption in standby mode is reduced to 0.036 W.

**User-friendly thanks to the BlueBUS system:** which enables connection by means of just two wires between the control unit and pair of photocells.

**Safe:** obstacle detection system and automatic programming of the working times; motor absorption is monitored during movement, self-diagnosis by means of a flashing light and courtesy light. Acceleration and deceleration can be adjusted at the beginning and end of each opening and closing manoeuvre. Can be connected with latest generation sensitive edges 8.2 KOhm.

**Luminous:** 40 W lamp that can be used as garage lightning.



BY ROTATING THE "PETAL" WHICH DIFFUSES THE LIGHT USERS ACCESS THE INCORPORATED BLUEBUS CONTROL UNIT

CODE	DESCRIPTION	PACK/PALLET
SN6031	IRREVERSIBLE, 230 Vac, 24 Vdc MOTOR, WITH INCORPORATED CONTROL UNIT, 800 N	15
SN6041	IRREVERSIBLE, 230 Vac, 24 Vdc MOTOR, WITH INCORPORATED CONTROL UNIT, 1000 N	15

CODE	DESCRIPTION	PACK/PALLET
SNA30	PREASSEMBLED 3 m GUIDE	1
SNA31	1 m EXTENSION FOR GUIDE SNA30	1

## TECHNICAL SPECIFICATIONS

CODE	SN6031	SN6041
<b>ELECTRICAL DATA</b>		
POWER SUPPLY (Vac 50/60 Hz)	230	
ABSORPTION (A)	1.3	1.4
POWER (W)	350	370
<b>PERFORMANCE DATA</b>		
SPEED (m/s)	0.20	
FORCE (N)	800	1000
WORK CYCLE (CYCLES/DAY)	50	
<b>DIMENSIONAL AND GENERAL DATA</b>		
PROTECTION LEVEL (IP)	40	
WORKING TEMP. (°C MIN/MAX)	-20 ÷ +50	
DIMENSIONS (mm)	311x327x105 h	
WEIGHT (kg)	3.6	4.7

## UTILISATION LIMITS

Using the maximum travel

	NON-PROJECTING UP-AND-OVER DOOR		PROJECTING UP-AND-OVER DOOR		SECTIONAL	
	H	L	H	L	H	L
SN6031 WITH SNA30	2.2 m	4.2 m	2.8 m	4.2 m	2.4 m	5 m
SN6041 WITH SNA30	2.2 m	4.2 m	2.8 m	4.2 m	2.4 m	5.2 m
SN6031 WITH SNA30 + SNA31	3.2 m	2.9 m	3.5 m	3.4 m	3.4 m	3.5 m
SN6041 WITH SNA30 + SNA31	3.2 m	4.2 m	3.5 m	4.2 m	3.4 m	5.2 m

## DIMENSIONS

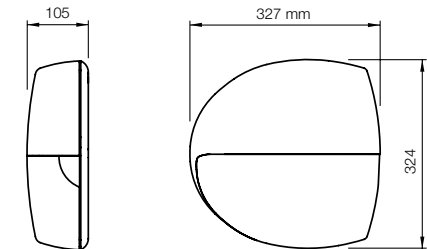



## ACCESSORIES

## KIT SOLEMYO



**SNA3**  
SPARE CONTROL UNIT  
FOR SPIN30/SN6031.



**SNA4**  
SPARE CONTROL UNIT  
FOR SPIN40/SN6041.



**PS124**  
24 V BATTERY  
WITH INTEGRATED  
BATTERY CHARGER.  
PC/PACK 1



**SPA2**  
KIT FOR UNLOCKING FROM  
THE OUTSIDE WITH CABLE.  
PC/PACK 1



**SPA5**  
OSCILLATING ARM SLIDING  
ON BEARINGS WITH OPTIMISED  
STRUCTURE FOR PROJECTING  
UP-AND-OVER DOORS.  
PC/PACK 1



**SPA6**  
LARGE 585 mm LONG  
CONNECTING ARM.  
PC/PACK 1



**SPA7**  
KIT OF TWO ADDITIONAL  
FIXING BRACKETS.  
PC/PACK 2



**SNA16**  
QUICK-CONNECT BRACKETS  
FOR CEILING MOUNTING.  
PC/PACK 10



● THE SOLAR POWER  
KIT SOLEMYO TO AUTOMATE  
GATES, GARAGE DOORS  
OR BARRIER GATES,  
INCLUDING THOSE LOCATED  
FAR FROM THE POWER MAINS  
AND WITHOUT THE NEED  
FOR COSTLY AND INVASIVE  
EXCAVATION WORK.  
SEE PAGE 171



**TS**  
SIGNBOARD.

PC/PACK 1

## INSTALLATION DIAGRAM

### Sectional

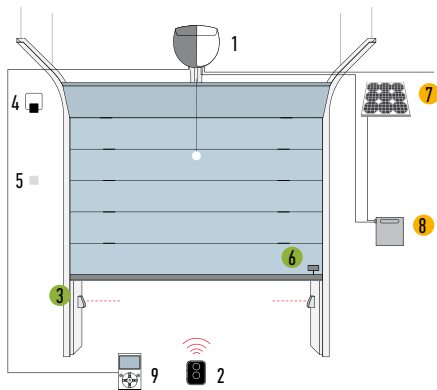

### Non-projecting up-and-over door

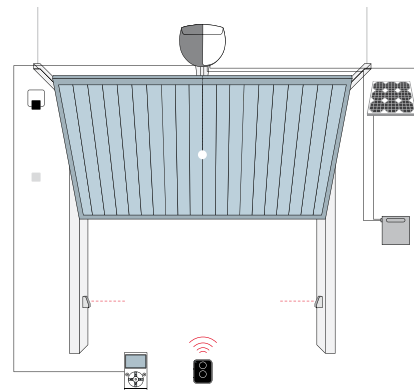

### Projecting up-and-over door

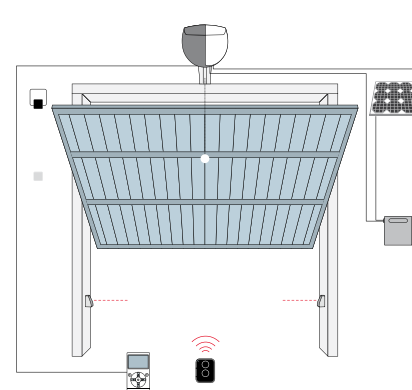

1. MOTOR
2. TRANSMITTER
3. PHOTOCELLS
4. FLASHING LIGHT
5. DIGITAL OR KEY SWITCHES
6. SENSOR FOR SENSITIVE EDGES
7. SYP SOLAR PANEL
8. PSY24 BATTERY BOX
9. 0-VIEW MULTIFUNCTION DISPLAY

- ACCESSORIES ALSO AVAILABLE FOR THE Solemyo Air Net System WIRELESS VERSION
- Solemyo SOLAR POWER ACCESSORIES

# SPINBUSKIT 20/21/22

BLUEBUS 24V

For sectional doors up to 10.5 m<sup>2</sup>  
and up-and-over garage doors up to 11.8 m<sup>2</sup>.

### Three versions in kit:

- pre-mounted, **guide in three 1-metre sections** SPIN20KCE,
- **with pre-mounted guide of 3 m** SPIN21KCE or **pre-mounted**
- **guide of 4 m (3+1 m)** SPIN22KCE.

### Rapid installation - anywhere!

The adjustable head, cord-type release and cable-controlled, step-by-step release can be fitted in any part of the garage in order to actuate the system without a remote control device and without the need to install wall-mounted control units!

### User-friendly thanks to the BlueBUS system:

which enables connection by means of just two wires between the control unit and pair of photocells.

**Safe:** obstacle detection system and automatic programming of the working times; motor absorption is monitored during movement, self-diagnosis by means of a flashing light and courtesy light.

Acceleration and deceleration can be adjusted at the beginning and end of each opening and closing manoeuvre.

Can be connected with last generation sensitive edges 8.2 KOhm.

**Courtesy light:** 21 W lamp.

CODE	DESCRIPTION	PACK/PALLET
SPIN20KCE	KIT FOR AUTOMATING SECTIONAL AND UP-AND-OVER DOORS. GUIDE IN THREE 1-METRE SECTIONS	14
SPIN21KCE	KIT FOR AUTOMATING SECTIONAL AND UP-AND-OVER DOORS. PRE-MOUNTED GUIDE OF 3 m	15
SPIN22KCE	KIT FOR AUTOMATING SECTIONAL AND UP-AND-OVER DOORS. GUIDE IN ONE 3-METRE SECTION + ONE 1-METRE SECTION	15

**N.B.** The content of the package may vary: consult the retailer.

### TECHNICAL SPECIFICATIONS

CODE	SN6021
<b>ELECTRICAL DATA</b>	
POWER SUPPLY (Vac 50/60 Hz)	230
ABSORPTION (A)	0.8
POWER (W)	250
<b>PERFORMANCE DATA</b>	
SPEED (m/s)	0.20
FORCE (N)	650
WORK CYCLE (CYCLES/DAY)	50
<b>DIMENSIONAL AND GENERAL DATA</b>	
PROTECTION LEVEL (IP)	40
WORKING TEMP. (°C MIN/MAX)	-20 ÷ +50
DIMENSIONS (mm)	311x327x105 h
WEIGHT (kg)	3.6

### UTILISATION LIMITS

Using the maximum travel

	NON-PROJECTING UP-AND-OVER DOOR		PROJECTING UP-AND-OVER DOOR		SECTIONAL	
	H	L	H	L	H	L
SPIN20KCE	2.2 m	4.2 m	2.8 m	4.2 m	2.4 m	4.4 m
SPIN21KCE	2.2 m	4.2 m	2.8 m	4.2 m	2.4 m	4.4 m
SPIN22KCE	3.2 m	2.9 m	3.5 m	3.4 m	3.4 m	3.1 m

### DIMENSIONS

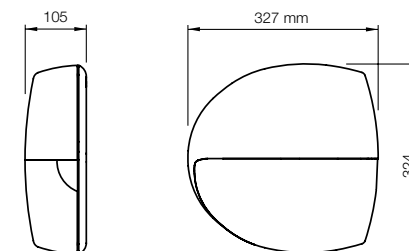

### THE KIT CONTAINS:

**SN6021**  
1 GEAR MOTOR WITH  
BUILT-IN SNA2 CONTROL  
UNIT AND SMXI PLUG-IN  
RECEIVER.



**FLO2RE**  
1 TRANSMITTER  
433.92 MHz, 2 CHANNELS.



**SPIN20KCE**  
GUIDE  
IN THREE 1-METRE SECTIONS.

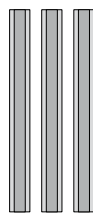

3 x 1 m

**SPIN21KCE**  
GUIDE  
IN ONE 3-METRE SECTION.



1 x 3 m

**SPIN22KCE**  
GUIDE  
IN ONE 3-METRE SECTION.  
+ ONE 1-METRE SECTION.

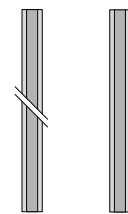

1 x 3 m 1 x 1 m

## ACCESSORIES



**SNA2**  
SPARE CONTROL UNIT  
FOR SPIN20KCE, SPIN21KCE  
AND SPIN22KCE.



**SPA2**  
KIT FOR UNLOCKING FROM  
THE OUTSIDE WITH CABLE.  
PC/PACK 1



**SPA5**  
OSCILLATING ARM SLIDING  
ON BEARINGS WITH  
OPTIMISED STRUCTURE  
FOR PROJECTING  
UP-AND-OVER DOORS.  
PC/PACK 1



**SPA6**  
LARGE 585 mm LONG  
CONNECTING ARM.  
PC/PACK 1



**SPA7**  
KIT OF TWO ADDITIONAL  
FIXING BRACKETS.  
PC/PACK 2



**SNA16**  
QUICK-CONNECT BRACKETS  
FOR CEILING MOUNTING.  
PC/PACK 10



**TS**  
SIGNBOARD.  
PC/PACK 1



## INSTALLATION DIAGRAM

### Sectional

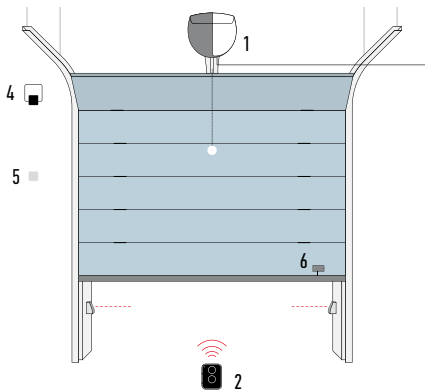

### Non-projecting up-and-over door

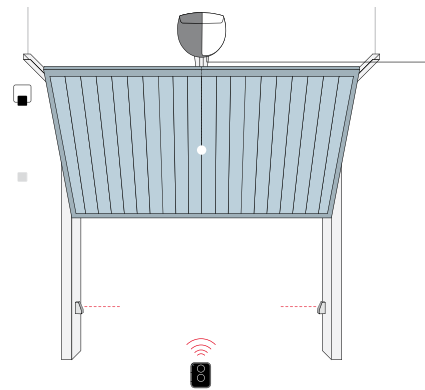

### Projecting up-and-over door

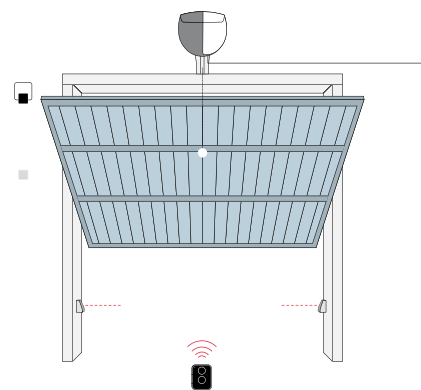

1. MOTOR
2. TRANSMITTER
3. PHOTOCELLS
4. FLASHING LIGHT
5. DIGITAL OR KEY SWITCHES
6. SENSOR FOR SENSITIVE EDGES

Nice recommends customers order products in pallets in order to facilitate storage and delivery, and ensure packs are uniform. The number of packs per single pallet has been specified for this reason. Approximate draft.

# SPINBUSKIT 23

SOLEMYO OPERA BLUEBUS 24V

For sectional doors up to 10.5 m<sup>2</sup>  
and up-and-over garage doors up to 11.8 m<sup>2</sup>.

With pre-mounted 3-metre guide.

Rapid installation - anywhere!

The adjustable head, cord-type release and cable-controlled, step-by-step release can be fitted in any part of the garage in order to actuate the system without a remote control device and without the need to install wall-mounted control units!

**Guaranteed savings and respect for the environment:**  
with connection to the mains in standby mode the control unit with radio connected consumes just 5.2 W; when connected to a battery or to the Solemyo kit, consumption on standby is reduced to 0.036 W.

**Safe:** obstacle detection system and automatic programming of the working times; motor absorption is monitored during movement, self-diagnosis by means of a flashing light and courtesy light. Acceleration and deceleration can be adjusted at the beginning and end of each opening and closing manoeuvre. Can be connected with last generation sensitive edges 8.2 KOhm.

**Courtesy light:** 21 W lamp.

**No black out:** operation in the event of a power failure with optional batteries (PS124) housed inside the motor.

CODE	DESCRIPTION	PACK/PALLET
SPIN23KCE	KIT FOR AUTOMATING SECTIONAL AND UP-AND-OVER DOORS. PRE-MOUNTED GUIDE IN ONE 3-METRE SECTION	15

**N.B.** The content of the package may vary; consult the retailer.

## TECHNICAL SPECIFICATIONS

CODE	SN6021
<b>ELECTRICAL DATA</b>	
POWER SUPPLY (Vac 50/60 Hz)	230
ABSORPTION (A)	0.8
POWER (W)	250
<b>PERFORMANCE DATA</b>	
SPEED (m/s)	0.20
FORCE (N)	650
WORK CYCLE (CYCLES/DAY)	50
<b>DIMENSIONAL AND GENERAL DATA</b>	
PROTECTION LEVEL (IP)	40
WORKING TEMP. (°C MIN/MAX)	-20 ÷ +50
DIMENSIONS (mm)	311x327x105 h
WEIGHT (kg)	3.6

## UTILISATION LIMITS

Using the maximum travel

	NON-PROJECTING UP-AND-OVER DOOR		PROJECTING UP-AND-OVER DOOR		SECTIONAL	
	H	L	H	L	H	L
SPIN23KCE	2.2 m	4.2 m	2.8 m	4.2 m	2.4 m	4.4 m

## DIMENSIONS

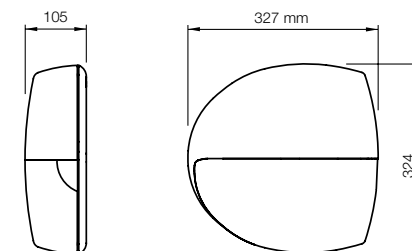

## THE KIT CONTAINS:

**SN6021**  
1 GEAR MOTOR WITH BUILT-IN CONTROL UNIT AND SMXI PLUG-IN RECEIVER.



**FLO2RE**  
1 TRANSMITTER  
433.92 MHz, 2 CHANNELS.



**SNA30**  
GUIDE  
IN ONE 3-METRE SECTION.

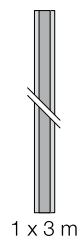



**SNA20**  
SPARE CONTROL UNIT  
FOR SPIN23KCE.



**PS124**  
24 V BATTERY  
WITH INTEGRATED  
BATTERY CHARGER.  
PC/PACK 1



**SPA2**  
KIT FOR UNLOCKING FROM  
THE OUTSIDE WITH CABLE.  
PC/PACK 1



**SPA5**  
OSCILLATING ARM SLIDING  
ON BEARINGS WITH OPTIMISED  
STRUCTURE FOR PROJECTING  
UP-AND-OVER DOORS.  
PC/PACK 1



**SPA6**  
LARGE 585 mm LONG  
CONNECTING ARM.  
PC/PACK 1



**SPA7**  
KIT OF TWO ADDITIONAL  
FIXING BRACKETS.  
PC/PACK 2



**SNA16**  
QUICK-CONNECT BRACKETS  
FOR CEILING MOUNTING.  
PC/PACK 10



● THE SOLAR POWER  
KIT SOLEMYO TO AUTOMATE  
GATES, GARAGE DOORS  
OR BARRIER GATES,  
INCLUDING THOSE LOCATED  
FAR FROM THE POWER MAINS  
AND WITHOUT THE NEED  
FOR COSTLY AND INVASIVE  
EXCAVATION WORK.  
SEE PAGE 171



**TS**  
SIGNBOARD.  
PC/PACK 1



INSTALLATION DIAGRAM

Sectional

Non-projecting up-and-over door

Projecting up-and-over door

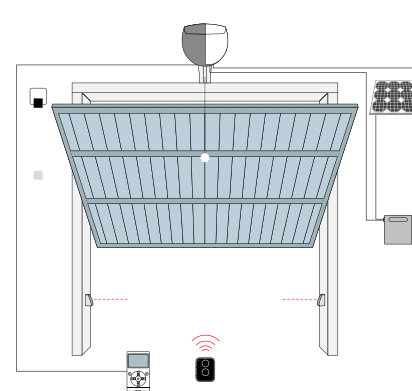
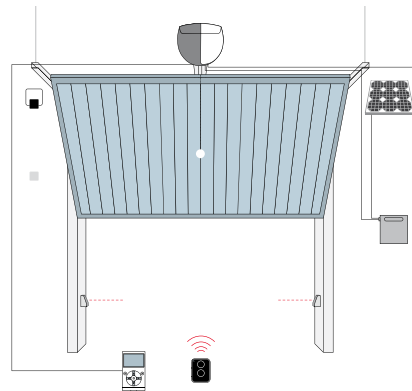
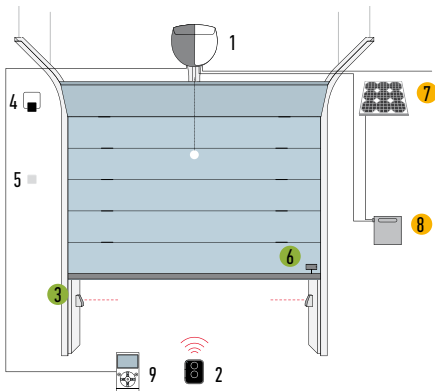

1. MOTOR
2. TRANSMITTER
3. PHOTOCELLS
4. FLASHING LIGHT
5. DIGITAL OR KEY SWITCHES
6. SENSOR FOR SENSITIVE EDGES
7. SYP SOLAR PANEL
8. PSY24 BATTERY BOX
9. 0-VIEW MULTIFUNCTION DISPLAY

- ACCESSORIES ALSO AVAILABLE FOR THE Solemyo Air Net System WIRELESS VERSION
- Solemyo SOLAR POWER ACCESSORIES

Nice recommends customers order products in pallets in order to facilitate storage and delivery, and ensure packs are uniform. The number of packs per single pallet has been specified for this reason. Approximate draft.

# SPINKIT

24V

**For sectional doors up to 8.8 m<sup>2</sup> and up-and-over garage doors up to 9.8 m<sup>2</sup>, belt drive.**

**Two versions in kit:**

- pre-assembled, 3x1 m sections guide (SPIN10KCE)
- pre-assembled 3 m guide (SPIN11KCE).

**Advanced:** incorporated radio card, compatible with the Nice Flo, FloR and Smilo systems: 150 transmitters can be entered! Input for photocells and possibility of connecting photo-test with self-learning function during installation.

**Safe:** obstacle detection system and automatic programming of the working times; motor absorption is monitored during movement, self-diagnosis by means of a flashing light and courtesy light. Acceleration and deceleration can be adjusted at the beginning and end of each opening and closing manoeuvre. Can be connected with last generation sensitive edges 8.2 KOhm.

CODE	DESCRIPTION
SPIN10KCE	KIT FOR AUTOMATING SECTIONAL AND UP-AND-OVER DOORS. 3X1 m-SECTIONS LINEAR GUIDE
SPIN11KCE	KIT FOR AUTOMATING SECTIONAL AND UP-AND-OVER DOORS. 3 m PRE-ASSEMBLED GUIDE

**N.B.** The content of the package may vary: consult the retailer.

## TECHNICAL SPECIFICATIONS

CODE	SN6011
<b>ELECTRICAL DATA</b>	
POWER SUPPLY (Vac 50/60 Hz)	230
ABSORPTION (A)	0.7
POWER (W)	200
<b>PERFORMANCE DATA</b>	
SPEED (m/s)	0.14
FORCE (N)	550
WORK CYCLE (CYCLES/DAY)	30
<b>DIMENSIONAL AND GENERAL DATA</b>	
PROTECTION LEVEL (IP)	40
WORKING TEMP. (°C MIN/MAX)	-20 ÷ +50
DIMENSIONS (mm)	225x330x100 h
WEIGHT (kg)	3.3

## UTILISATION LIMITS

Using the maximum travel

	NON-PROJECTING UP-AND-OVER DOOR		PROJECTING UP-AND-OVER DOOR		SECTIONAL	
	H	L	H	L	H	L
SPIN10KCE	2.2 m	3.5 m	2.8 m	3.5 m	2.4 m	3.7 m
SPIN11KCE	2.2 m	3.5 m	2.8 m	3.5 m	2.4 m	3.7 m

## DIMENSIONS

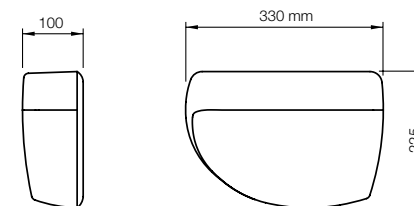

## THE KIT CONTAINS:

**SN6011**  
1 GEAR MOTOR SN6011 WITH INCORPORATED CONTROL UNIT AND PLUG-IN RECEIVER.



**FLO2RE**  
1 TRANSMITTER  
433.92 MHz, 2 CHANNELS.



**SPIN10KCE**  
GUIDE  
IN THREE 1-METRE SECTIONS.

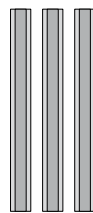

3 x 1 m

**SPIN11KCE**  
GUIDE  
IN ONE 3-METRE SECTION.



1 x 3 m

ACCESSORIES



**SNA1**  
SPARE CONTROL UNIT  
FOR SPIN10KCE  
AND SPIN11KCE.



**SPA2**  
KIT FOR UNLOCKING FROM  
THE OUTSIDE WITH CABLE.  
PC/PACK 1



**SPA5**  
OSCILLATING ARM SLIDING  
ON BEARINGS WITH OPTIMISED  
STRUCTURE FOR PROJECTING  
UP-AND-OVER DOORS.  
PC/PACK 1



**SPA6**  
LARGE 585 mm LONG  
CONNECTING ARM.  
PC/PACK 1



**SPA7**  
KIT OF TWO ADDITIONAL  
FIXING BRACKETS.  
PC/PACK 2



**SNA16**  
QUICK-CONNECT BRACKETS  
FOR CEILING MOUNTING.  
PC/PACK 10



**TS**  
SIGNBOARD.  
PC/PACK 1



INSTALLATION DIAGRAM

Sectional

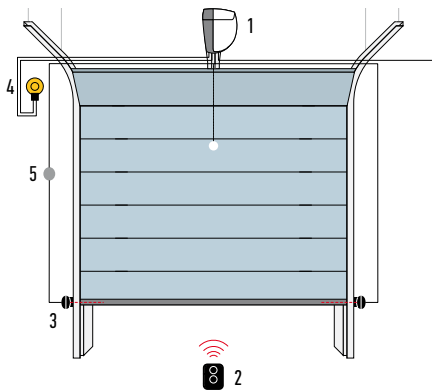

Non-projecting up-and-over door

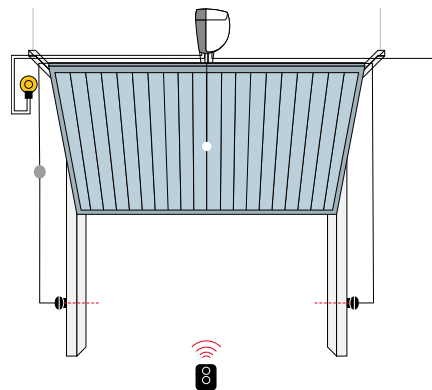

Projecting up-and-over door

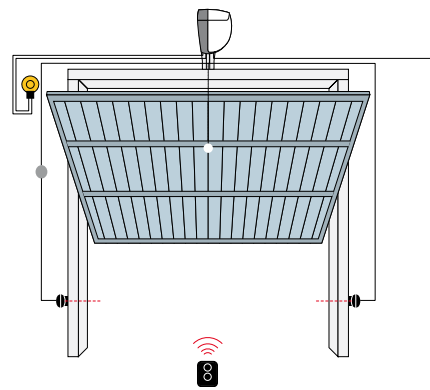

- 1. MOTOR
- 2. TRANSMITTER
- 3. PHOTOCELLS
- 4. FLASHING LIGHT
- 5. DIGITAL OR KEY SWITCHES

Nice recommends customers order products in pallets in order to facilitate storage and delivery, and ensure packs are uniform. The number of packs per single pallet has been specified for this reason. Approximate draft.

**For projecting and non projecting up-and-over doors up to 9 m<sup>2</sup> (up to 16 m<sup>2</sup> using 2 motors). 24 Vdc electromechanical gear motor.**

**Three versions, standard and upgraded:**

- with built-in control unit, force regulator and absolute encoder (TN2010L);
- with incorporated control unit and receiver, electromechanical limit switch (TN2030L);
- without control unit (TN2020L).

**Reliable and precise:** memorisation of the opening and closing limit switch positions; gradual starting and slowdown during closing.

**Safe:** obstacle detection system and monitoring of the motor absorption during movement, self-diagnosis by means of a flashing light, courtesy light. The latest generation optical and resistive 8.2 KOhm sensitive edges can also be connected.

**Functional:** possibility to connect a second motor without control unit TN2020L, to automate doors up to 16 m<sup>2</sup>.

**TN2030L model with built-in radio receiver compatible with Nice system Flo, FloR and Smilo.**

**TN2010L version with BlueBUS technology and compatible for operation with Solemyo and Opera systems.**

**Advanced:** the absolute encoder technology guarantees precision without the need of a limit switch, reliability and the long term safeguard of the set values.

**Simple:** thanks to the BlueBUS technology which enables connection by means of just two wires between the control unit and photocells.

**Energy saving:** the system enters in stand-by when not in use.

**Practical:** the control unit and PS324 buffer battery (optional) can be connected by means of a simple connector and can be housed directly inside the motor.

Compatible with Nice SMXI and OXI plug-in receivers (optional).



CODE	DESCRIPTION	PACK/PALLET
TN2010L	IRREVERSIBLE, 24 Vdc, WITH INCORPORATED CONTROL UNIT, COURTESY LIGHT, ABSOLUTE ENCODER WITH BLUEBUS TECHNOLOGY, COMPATIBLE FOR OPERA AND SOLEMYO SYSTEMS. UPGRADED VERSION	15
TN2030L	IRREVERSIBLE, 24 Vdc, WITH INCORPORATED CONTROL UNIT AND RECEIVER, COURTESY LIGHT AND ELECTROMECHANICAL LIMIT SWITCH. UPGRADED VERSION	15
TN2020L	IRREVERSIBLE, 24 Vdc, WITH COURTESY LIGHT, WITHOUT INCORPORATED CONTROL UNIT. UPGRADED VERSION	15

**TECHNICAL SPECIFICATIONS**

CODE	TN2010L	TN2010L+TN2020L	TN2030L	TN2030L+TN2020L
<b>ELECTRICAL DATA</b>				
POWER SUPPLY (Vac 50/60 Hz)	230			
ABSORPTION (A)	1	1.4		1.4
POWER (W)	240	350	220	330
<b>PERFORMANCE DATA</b>				
SPEED (rpm)	1.4	1.7	1.4	1.4
TORQUE (Nm)	600	750	420	700
WORK CYCLE (CYCLES/HOUR)	15	25	20	10
<b>DIMENSIONAL AND GENERAL DATA</b>				
PROTECTION LEVEL (IP)	44			
WORKING TEMP. (°C MIN/MAX)	-20 ÷ +50			
DIMENSIONS (mm)	150x158x512 h			
WEIGHT (kg)	10	17.2*	9.5	16.7*

\* 7.2 for TN2020/TN2020L

**UTILISATION LIMITS**

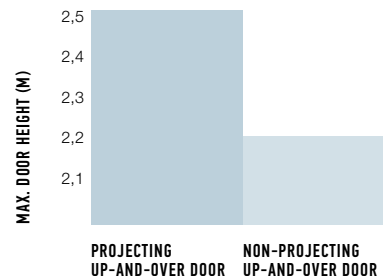

**DIMENSIONS**

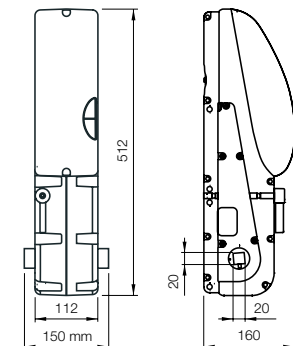

N.B. The values indicated above refer to the use of motors with standard accessories.





**TNA1**  
SPARE CONTROL UNIT  
FOR TN2030L AND TNLKCE.



**TNA2**  
SPARE CONTROL UNIT  
FOR TN2010L.



**PS324**  
24 V BATTERY WITH  
INTEGRATED BATTERY  
CHARGER.  
ONLY FOR TN2010L.  
PC/PACK 1



**TNA9**  
ADDITIONAL CONNECTION  
CABLE AND SUPPORTS  
FOR WALL-MOUNTING  
OF PS324 BATTERY.  
PC/PACK 1



**OTA2**  
MOTOR SUPPORT BRACKET  
(1250 mm LONG).  
PC/PACK 1



**OTA3**  
MOTOR SUPPORT BRACKET  
(2000 mm LONG).  
PC/PACK 1



**OTA9**  
MOTOR SUPPORT BRACKET  
(520 mm LONG).  
PC/PACK 1



**TNA5**  
PAIR OF STANDARD STRAIGHT  
TELESCOPIC ARMS.  
PC/PACK 1



● THE SOLAR POWER  
KIT SOLEMYO TO AUTOMATE  
GATES, GARAGE DOORS  
OR BARRIER GATES,  
INCLUDING THOSE LOCATED  
FAR FROM THE POWER MAINS  
AND WITHOUT THE NEED  
FOR COSTLY AND INVASIVE  
EXCAVATION WORK.  
SEE PAGE 171



**TNA6**  
PAIR OF STANDARD CURVED  
TELESCOPIC ARMS.  
PC/PACK 1



**TNA8**  
20X20 mm DRIVE SHAFT  
(200 mm LONG).  
PC/PACK 1



**TNA4**  
20X20 mm DRIVE SHAFT  
(1500 mm LONG).  
PC/PACK 1



**TNA38**  
DRIVING DEVICE FOR  
TRANSMISSION SHAFTS.  
PC/PACK 1



**OTA11**  
KIT FOR UNLOCK  
FROM THE OUTSIDE  
WITH A METAL CORD.  
PC/PACK 1



**OTA12**  
KIT FOR EXTERNAL  
UNLOCKING WITH KEY  
RATCHET (CANNOT BE USED  
WITH LATERALLY INSTALLED  
MOTORS).  
PC/PACK 1



**TS**  
SIGNBOARD.  
PC/PACK 1

INSTALLATION DIAGRAM

Non-projecting up-and-over door

Projecting up-and-over door

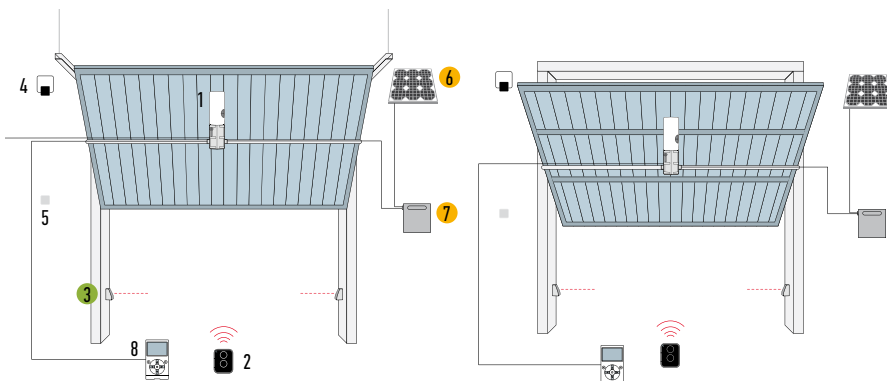

1. MOTOR
2. TRANSMITTER
3. PHOTOCELLS
4. FLASHING LIGHT
5. DIGITAL OR KEY SWITCHES
6. SYP SOLAR PANEL
7. PSY24 BATTERY BOX
8. 0-VIEW MULTIFUNCTION DISPLAY

FOR TN2010L MODEL:

- ACCESSORIES ALSO AVAILABLE FOR THE Solemyo Air Net System WIRELESS VERSION
- Solemyo SOLAR POWER ACCESSORIES

Nice recommends customers order products in pallets in order to facilitate storage and delivery, and ensure packs are uniform. The number of packs per single pallet has been specified for this reason. Approximate draft.

# TENKIT

24V

## For projecting and non projecting up-and-over doors up to 9 m<sup>2</sup>.

Irreversible electromechanical 24 Vdc gear motor.

**Functions:** standard input for photocells and possibility of connecting phototest function in self-learning mode during installation.

**Convenient:** built-in radio board compatible with the systems Nice Flo, FloR e Smilo: possibility of entering up to 150 transmitters.

Push-button programming and automatic position search.

**Adjustments:** 3 force levels, 2 speeds, 3 pause time levels, 3 step-by-step modes.

**Maximum safety:** provision for connection of latest generation 8.2 KOhm sensitive edges.

Obstacle detection and automatic programming of work times, monitoring of motor absorption throughout travel, self-diagnostics via the flashing light and courtesy light. Acceleration and deceleration at the start and end of each manoeuvre.

CODE	DESCRIPTION	PACK/PALLET
TNLKCE	IRREVERSIBLE, 24 Vdc, WITH INCORPORATED CONTROL UNIT AND RECEIVER, COURTESY LIGHT AND ELECTROMECHANICAL LIMIT SWITCH. UPGRADED VERSION	15

**N.B.** The content of the package may vary; consult the retailer.

### TECHNICAL SPECIFICATIONS

CODE	TNLKCE
<b>ELECTRICAL DATA</b>	
POWER SUPPLY (Vac 50/60 Hz)	230
ABSORPTION (A)	0.9
POWER (W)	200
<b>PERFORMANCE DATA</b>	
SPEED (rpm)	1.4
TORQUE (Nm)	420
WORK CYCLE (CYCLES/HOUR)	15
<b>DIMENSIONAL AND GENERAL DATA</b>	
PROTECTION LEVEL (IP)	44
WORKING TEMP. (°C MIN/MAX)	-20 ÷ +50
DIMENSIONS (mm)	150x158x512 h
WEIGHT (kg)	15.5

### UTILISATION LIMITS

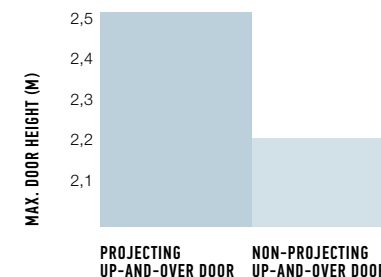

**N.B.** The values indicated above refer to the use of motors with standard accessories.

### DIMENSIONS

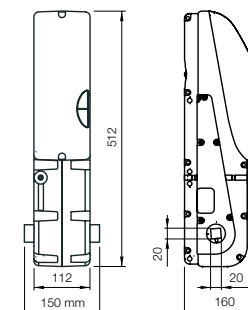

### THE KIT CONTAINS:

**TN2030L**  
1 IRREVERSIBLE ELECTROMECHANICAL GEAR MOTOR, WITH INCORPORATED CONTROL UNIT AND PLUG-IN RECEIVER, COURTESY LIGHT AND ELECTROMECHANICAL LIMIT SWITCH, COMPLETE WITH A PAIR OF STANDARD TELESCOPIC ARMS TNA5 AND WITH RELATIVE DRIVING DEVICES TNA38.



**FLO2RE**  
1 TRANSMITTER  
433.92 MHz, 2 CHANNELS.



**TS**  
1 SIGNBOARD.



## ACCESSORIES



**TNA1**  
SPARE CONTROL UNIT  
FOR TNKCE AND TNLKCE.



**OTA2**  
MOTOR SUPPORT BRACKET  
(1250 mm LONG).  
PC/PACK 1



**OTA3**  
MOTOR SUPPORT BRACKET  
(2000 mm LONG).  
PC/PACK 1



**OTA9**  
MOTOR SUPPORT BRACKET  
(520 mm LONG).  
PC/PACK 1



**TNA5**  
PAIR OF STANDARD STRAIGHT  
TELESCOPIC ARMS.  
PC/PACK 1



**TNA6**  
PAIR OF STANDARD CURVED  
TELESCOPIC ARMS.  
PC/PACK 1



**TNA8**  
20X20 mm DRIVE SHAFT  
(200 mm LONG).  
PC/PACK 1



**TNA4**  
20X20 mm DRIVE SHAFT  
(1500 mm LONG).  
PC/PACK 1



**TNA38**  
DRIVING DEVICE  
FOR TRANSMISSION  
SHAFTS.  
PC/PACK 1



**OTA11**  
KIT FOR UNLOCK  
FROM THE OUTSIDE  
WITH A METAL CORD.  
PC/PACK 1



**OTA12**  
KIT FOR EXTERNAL  
UNLOCKING WITH KEY  
RATCHET (CANNOT BE USED  
WITH LATERALLY INSTALLED  
MOTORS).  
PC/PACK 1



**TS**  
SIGNBOARD.  
PC/PACK 1

## INSTALLATION DIAGRAM

### Non-projecting up-and-over door

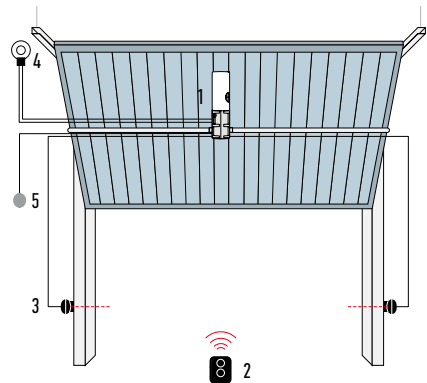

### Projecting up-and-over door

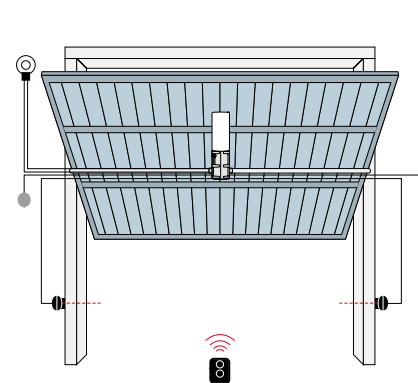

1. MOTOR
2. TRANSMITTER
3. PHOTOCELLS
4. FLASHING LIGHT
5. DIGITAL OR KEY SWITCHES



Nice recommends customers order products in pallets in order to facilitate storage and delivery, and ensure packs are uniform. The number of packs per single pallet has been specified for this reason. Approximate draft.

# SOON

SOLEMYO OPERA BLUEBUS 24V

**For sectional doors\* up to 20 m<sup>2</sup>.**  
24 Vdc electromechanical gear motor  
with absolute encoder.

\*For balanced sectional doors equipped with anti-crash  
(safety device useful in case of spring breaking).

**Easy to install:** Soon can be fitted directly onto the shaft  
of a sectional door; compact, particularly in width, in order  
to make assembly easy in any position.

**User-friendly thanks to the BlueBUS system**  
that enables users to connect the photocell couples  
and control unit using just two wires.

**Practical:** the control unit and PS124 buffer battery (optional)  
can be connected by means of a simple connector and can be  
housed directly inside the motor.

**Energy saving:** when the system is not being used it will  
switch over to standby.

**Reliable and precise:** memorization of limit switch positions  
on opening and closing; gradual starting and slowdown during  
closing; the absolute encoder technology guarantees precision  
without the need of a limit switch, reliability and long term  
safeguard of the set values.

**Safe:** obstacle detection system; motor absorption is monitored  
during movement, self-diagnosis by means of a flashing light  
and courtesy light.

Last generation of 8.2 KOhm optical and sensitive edges can also  
be connected.



CODE	DESCRIPTION	PACK/PALLET
S02000	IRREVERSIBLE, 24 Vdc, WITH ABSOLUTE ENCODER FOR DOORS UP TO 5 m IN HEIGHT	20

## TECHNICAL SPECIFICATIONS

CODE	S02000
<b>ELECTRICAL DATA</b>	
POWER SUPPLY (Vac 50/60 Hz)	230
ABSORPTION (A)	1.6
POWER (W)	350
<b>PERFORMANCE DATA</b>	
SPEED (rpm)	30
TORQUE (Nm)	50
WORK CYCLE (CYCLES/HOUR)	15
<b>DIMENSIONAL AND GENERAL DATA</b>	
PROTECTION LEVEL (IP)	40
WORKING TEMP. (°C MIN/MAX)	-20 ÷ +50
DIMENSIONS (mm)	115x300x375 h
WEIGHT (kg)	10.5

## DIMENSIONS

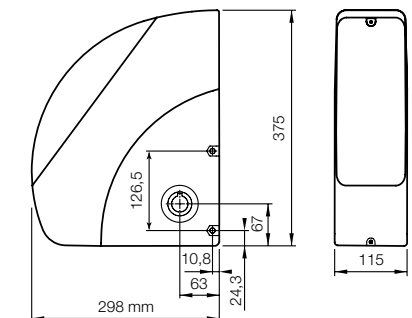



**SOA2**  
SPARE CONTROL UNIT  
FOR SO2000.



**PS124**  
24 V BATTERY  
WITH INTEGRATED  
BATTERY CHARGER.  
PC/PACK 1



**CRA9**  
ADAPTER FOR DIAMETER  
31.75 (1.1/4\"), 35  
AND 40 mm SHAFTS.  
PC/PACK 1



**TS**  
SIGNBOARD.  
PC/PACK 1



● THE SOLAR POWER KIT SOLEMYO TO AUTOMATE GATES, GARAGE DOORS OR BARRIER GATES, INCLUDING THOSE LOCATED FAR FROM THE POWER MAINS AND WITHOUT THE NEED FOR COSTLY AND INVASIVE EXCAVATION WORK. SEE PAGE 171

INSTALLATION DIAGRAM

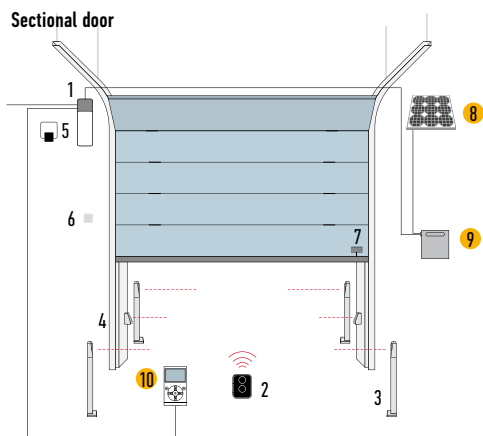

- 1. MOTOR
- 2. TRANSMITTER
- 3. PHOTOCELLS MOUNTED ON POSTS
- 4. PHOTOCELLS
- 5. FLASHING LIGHT
- 6. DIGITAL OR KEY SWITCHES
- 7. SENSITIVE EDGES SENSOR
- 8. SYP SOLAR PANEL
- 9. PSY24 BATTERY BOX
- 10. 0-VIEW MULTIFUNCTION DISPLAY

- ACCESSORIES ALSO AVAILABLE FOR THE Solemyo Air Net System WIRELESS VERSION
- Solemyo SOLAR POWER ACCESSORIES

Nice recommends customers order products in pallets in order to facilitate storage and delivery, and ensure packs are uniform. The number of packs per single pallet has been specified for this reason. Approximate draft.

# SUMO

24V

## For sectional doors and two-wings sliding doors up to 35 m<sup>2</sup>.

24 Vdc electromechanical gear motor with magnetic encoder, no need to adjust limit switches.

Perfect for intensive use.

**Revolutionary aesthetics:** compact, particularly in width, in order to make assembly easy in any position; quick to install.

**Easy to install:** Sumo can be fitted directly onto the shaft of sectional doors.

Perfect for Ø 25.4 mm shafts and can be used also with Ø 31.75-35-40 mm shafts thanks to the CRA9 adapter.

## Many different functions with the separate Mindy A924 control unit:

- automatic memorization of limit switches on opening and closing;
- gradual departure and slowdown during closing;
- integrated battery charge card with optional battery power supply in the event of power failures easy programming by pressing a single button;
- pause time programming and speed adjustment;
- "service" warning light for maintenance (can be programmed according to the number of manoeuvre required).

CODE	DESCRIPTION	PACK/PALLET
<b>SU2000</b>	IRREVERSIBLE 24 Vdc, WITH MAGNETIC ENCODER, NO NEED TO ADJUST LIMIT SWITCHES, FROM 15 M <sup>2</sup> UP TO 35 M <sup>2</sup>	20
<b>SU2000V</b>	IRREVERSIBLE 24 Vdc, WITH MAGNETIC ENCODER, NO NEED TO ADJUST LIMIT SWITCHES, HIGH SPEED, FROM 10 M <sup>2</sup> UP TO 25 M <sup>2</sup>	20
<b>SU2000VV</b>	IRREVERSIBLE 24 Vdc, WITH MAGNETIC ENCODER, NO NEED TO ADJUST LIMIT SWITCHES, SUPER HIGH SPEED, FROM 10 M <sup>2</sup> UP TO 15 M <sup>2</sup>	20
<b>SU2010</b>	IRREVERSIBLE 24 Vdc, WITH MAGNETIC ENCODER, NO NEED TO ADJUST LIMIT SWITCHES, IP54, FROM 15 M <sup>2</sup> UP TO 35 M <sup>2</sup>	20

## TECHNICAL SPECIFICATIONS

CODE	SU2000	SU2000V	SU2000VV	SU2010
<b>ELECTRICAL DATA</b>				
POWER SUPPLY (Vdc)	24			
ABSORPTION (A)	13			
POWER (W)	500			
<b>PERFORMANCE DATA</b>				
SPEED (rpm)	16	23.5	42	16
TORQUE (Nm)	120	82	46	120
WORK CYCLE (%)	50			
<b>DIMENSIONAL AND GENERAL DATA</b>				
PROTECTION LEVEL (IP)	44			54
WORKING TEMP. (°C MIN/MAX)	-20 ÷ +50			
DIMENSIONS (mm)	110x270x350 h			
WEIGHT (kg)	10.5			

CASE TOTALLY MADE FROM THICK DIE-CAST ALUMINIUM

INSPECTION COMPARTMENT, EASY TO ACCESS FOR CONNECTIONS

RELEASE CORD, 6.5 m LONG, WITH EMERGENCY HANDLE



## DIMENSIONS

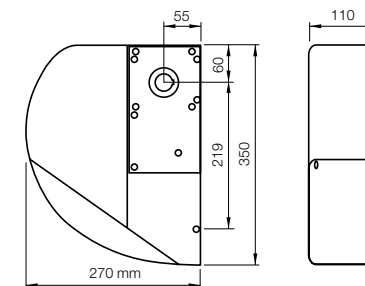

## ACCESSORIES

Nice recommends customers order products in order to facilitate storage and delivery, and ensure packs are uniform. The number of packs per single pallet has been specified for this reason. Approximate draft.



**A924**  
CONTROL UNIT.  
PC/PACK 1



**PUL**  
CENTRAL COVER WITH  
BUTTONS, COMPLETE WITH  
CONNECTING CABLE AND  
CONNECTED  
FOR A500 AND A924.  
PC/PACK 1



**B12-B**  
12 V, 6 Ah BATTERIES.  
PC/PACK 1



**BA3-A**  
NICE BATTERY BOX.



**K10**  
KEY-OPERATED SELECTOR  
SWITCH FOR LOW VOLTAGE  
CONTACTS WITH RELEASE  
MECHANISM FOR METAL  
CORD.  
PC/PACK 1



**KA1**  
6 m CABLE RELEASE KIT  
FOR K10.  
NOT REQUESTED  
FOR SU2010.  
PC/PACK 1



**CRA1**  
SHAFT WITH 18-TOOTH  
PINION Ø SHAFT 25.4 mm  
Ø INSIDE CROWN 25.4 mm.  
PC/PACK 1



**CRA2**  
JOINT FOR CHAIN.  
PC/PACK 1



**CRA3**  
1/2" CHAIN, 1 m PACK,  
PLUS JOINT FOR CHAIN.  
PC/PACK 1



**CRA4**  
1/2" CHAIN, 5 m PACK,  
IDEAL FOR SINGLE OR DOUBLE  
WING INDUSTRIAL DOORS,  
PLUS JOINT FOR CHAIN.  
PC/PACK 1



**CRA5**  
TENSIONER DRIVE  
WITH BRACKETS,  
FOR SINGLE OR DOUBLE  
WING INDUSTRIAL DOOR.  
PC/PACK 1



**CRA6**  
36-TOOTH PINION  
Ø INSIDE 25.4 mm.  
PC/PACK 1



**CRA7**  
18-TOOTH PINION  
Ø INSIDE 25.4 mm.  
PC/PACK 1



**CRA8**  
WALL-FIXING BRACKET.  
PC/PACK 2



**CRA9**  
ADAPTER FOR DIAMETER  
31.75 (1.1/4"), 35  
AND 40 mm SHAFTS.  
PC/PACK 1



**TS**  
SIGNBOARD.  
PC/PACK 1

## INSTALLATION DIAGRAM

### Sectional door

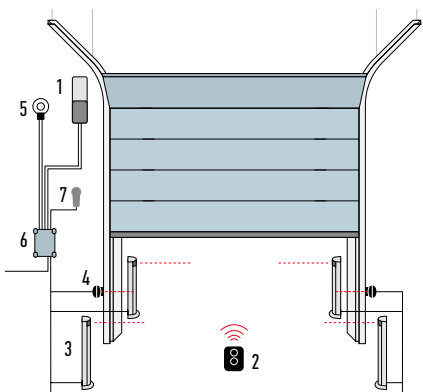

### Two-wings sliding doors

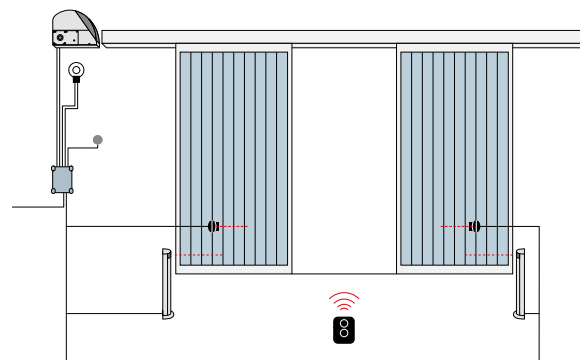

1. MOTOR
2. TRANSMITTER
3. PHOTOCELLS MOUNTED ON POSTS
4. PHOTOCELLS
5. FLASHING LIGHT
6. CONTROL UNIT
7. DIGITAL OR KEY SWITCHES

# HYPP0 7100

SOLEMYO OPERA BLUEBUS 24V 230V

## For 2-leaf folding doors.

Electromechanical gear motor irreversible with telescopic arm, also in 24 Vdc version, with magnetic encoder.

Single model for right and left leaves.

Pre-wired, **incorporated double limit-switch** both during opening and closing; fewer connections mean quicker installation (for HY7100 only).

**Solid metal mechanics.**

**Sturdy, galvanised, telescopic arm.**

### Recommended control units:

for HY7100 Mindy A6F, A60, A700F;  
for HY7124 Moonclever MC824H.

**24 Vdc version** with magnetic encoder.

**Perfect for intensive use**, compatible with the control unit Moonclever MC824H:

- simple programming, by means of a single key;
- self-learning of opening and closing limit positions;
- automatic fault diagnostics;
- programming of pause time;
- pedestrian pass door;
- deceleration on opening and closing;
- obstacle detection with dual technology;
- operation in event of power failure by means of optional rechargeable batteries (PS324);
- Can be connected with latest generation sensitive edges 8.2 KOhm.

COMPACT, SHOCKPROOF BODYWORK WITH NO SHARP CORNERS



NICE ALUMINIUM RELEASE, DESIGNED TO ACCOMMODATE EXTERNAL RELEASE

CODE	DESCRIPTION	PACK/PALLET
<b>HY7100</b>	IRREVERSIBLE, 230 Vac, WITH STURDY TELESCOPIC ARM, GALVANISED AND PAINTED, WITH LIMIT SWITCH ON OPENING AND CLOSING	16
<b>HY7124</b>	IRREVERSIBLE, 24 Vdc WITH MAGNETIC ENCODER, WITH TELESCOPIC ARM, GALVANISED AND PAINTED	16

## TECHNICAL SPECIFICATIONS

CODE	HY7100	HY7124
<b>ELECTRICAL DATA</b>		
POWER SUPPLY (Vac 50 Hz)*	230	-
POWER SUPPLY (Vdc)	-	24
ABSORPTION (A)	1.2	5
POWER (W)	250	120
<b>PERFORMANCE DATA</b>		
SPEED (rpm)	1.7	2
TORQUE (Nm)	400	250
WORK CYCLE (%)	30	80
<b>DIMENSIONAL AND GENERAL DATA</b>		
PROTECTION LEVEL (IP)	20	
WORKING TEMP. (°C MIN/MAX)	-20 ÷ +50	
DIMENSIONS (mm)	350x165x242 h	
WEIGHT (kg)	13	

\*60 Hz version available on request.

## UTILISATION LIMITS

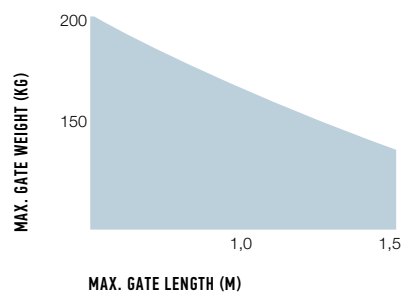

## DIMENSIONS

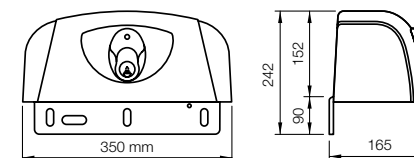

N.B. The above values are valid if the motor is used with standard accessories.



## ACCESSORIES



**HYA11**  
UNLOCK FROM INSIDE  
WITH A 6 m CORD.

PC/PACK 1



**KIO**  
KEY-OPERATED SELECTOR  
SWITCH FOR LOW VOLTAGE  
CONTACTS, WITH RELEASE  
MECHANISM FOR METAL CORD.

PC/PACK 1



**KA1**  
6 m CABLE RELEASE KIT  
FOR KIO.

PC/PACK 1



**TS**  
SIGNBOARD.

PC/PACK 1

## ACCESSORY

For 24 Vdc version



**PS324**  
24 V BATTERY  
WITH INTEGRATED  
BATTERY CHARGER.

PC/PACK 1

## INSTALLATION DIAGRAM

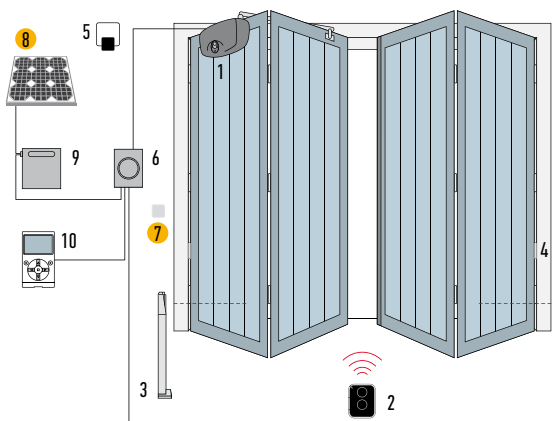

1. MOTOR
2. TRANSMITTER
3. PHOTOCELLS MOUNTED ON POSTS
4. PHOTOCELLS
5. FLASHING LIGHT
6. CONTROL UNIT
7. DIGITAL OR KEY SWITCHES
8. SYP SOLAR PANEL
9. PSY24 BATTERY BOX (FOR HY7124)
10. O-VIEW MULTIFUNCTION DISPLAY

FOR HY7124 MODEL:

- ACCESSORIES ALSO AVAILABLE FOR THE Solemyo Air Net System WIRELESS VERSION
- Solemyo SOLAR POWER ACCESSORIES

## KIT SOLEMYO



- THE SOLAR POWER KIT SOLEMYO TO AUTOMATE GATES, GARAGE DOORS OR BARRIER GATES, INCLUDING THOSE LOCATED FAR FROM THE POWER MAINS AND WITHOUT THE NEED FOR COSTLY AND INVASIVE EXCAVATION WORK. SEE PAGE 171

# RONDO

230V

## For balanced rolling doors.

Electromechanical gear motor with lifting force up to 130 kg and 180 kg.

**Smart:** the limit switch unit and wiring are protected by an elegant box; pre-wired capacitor.

**Fast:** easy and intuitive adjustment of the limit switches both during opening and closing.

**Complete:** supplied with 200 mm and 220 mm flange for 60 mm shafts, with 48 mm and 42 mm adaptors.

**Easy to install:** thanks to the guided connector, you don't need to hold the motor while you secure it using just 3 screws.

### Recommended control units:

Mindy A01 and A02, - easy to use, complete and reliable, featuring:

- semi-automatic or automatic operation;
- complete reverse run with photocell;
- step-by-step operation;
- programmable Step-by-step/Open input;
- programmable Stop/Photo input;
- input for resistive edge;
- incorporated radio card, compatible with the Nice Flo, FloR and Smilo systems.

COMPLETE: DESIGNED FOR CORDOPERATED RELEASE



STURDY: HOUSING IN 100% ALUMINIUM

PRACTICAL: EASY TO ADJUST, ELECTROMECHANICAL LIMIT SWITCHES BOTH DURING CLOSING AND OPENING

CODE	DESCRIPTION	PACK/PALLET
RN2010	REVERSIBLE, WITHOUT BRAKE, WITH LIFTING FORCE UP TO 130 kg	21
RN2020	REVERSIBLE, WITHOUT BRAKE, WITH LIFTING FORCE UP TO 180 kg	21
RN2030	IRREVERSIBLE, WITH BRAKE AND RELEASE DEVICE, WITH LIFTING FORCE UP TO 130 kg	21
RN2040	IRREVERSIBLE, WITH BRAKE AND RELEASE DEVICE, WITH LIFTING FORCE UP TO 180 kg	21

## TECHNICAL SPECIFICATIONS

CODE	RN2010	RN2030	RN2020	RN2040
<b>ELECTRICAL DATA</b>				
POWER SUPPLY (Vac 50 Hz)*	230			
ABSORPTION (A)	2			2.6
POWER (W)	450			600
<b>PERFORMANCE DATA</b>				
SPEED (rpm)	10			
TORQUE (Nm)	130			180
WORK CYCLE MAX (%)	50% WITH 30 S ON AND 30 S OFF			
<b>DIMENSIONAL AND GENERAL DATA</b>				
PROTECTION LEVEL (IP)	20			
WORKING TEMP. (°C MIN/MAX)	-20 ÷ +50			
DIMENSIONS (mm)	Ø 210x338	Ø 210x355	Ø 210x338	Ø 210x385
WEIGHT (kg)	9.5			10

\*60 Hz version available on request.

## DIMENSIONS

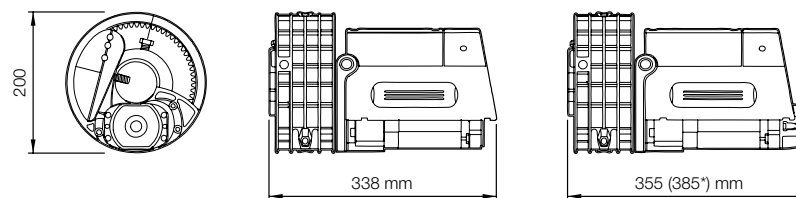

## ACCESSORIES



**A01**  
CONTROL UNIT.  
PC/PACK 1



**A02**  
CONTROL UNIT  
WITH AUTOMATIC CLOSING.  
PC/PACK 1



**K10**  
KEY-OPERATED SELECTOR  
SWITCH FOR LOW VOLTAGE  
CONTACTS, WITH RELEASE  
MECHANISM FOR METAL  
CORD.  
PC/PACK 1



**RNA01**  
ELECTRONIC BRAKE  
FOR RN2020 AND RN2010.  
PC/PACK 1



**TS**  
SIGNBOARD.  
PC/PACK 1

## INSTALLATION DIAGRAM

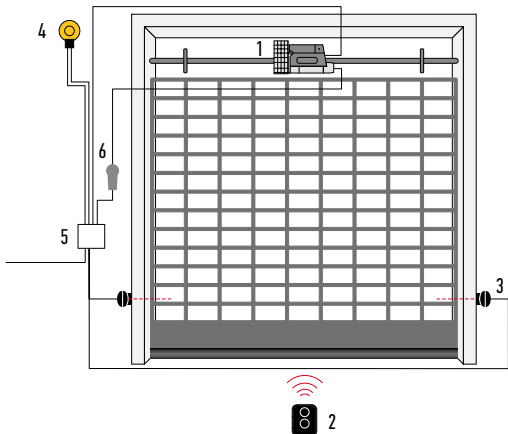

1. MOTOR
2. TRANSMITTER
3. PHOTOCELLS
4. FLASHING LIGHT
5. CONTROL UNIT
6. DIGITAL OR KEY SWITCHES



# CONTROL SYSTEMS



ERA RANGE	142	ERA TOUCH
RADIO CONTROL SYSTEMS	144	ERA INTI
	146	ERA ONE
	147	ERA FLOR
	148	RECEIVERS

---

OTHER TRANSMITTERS AND RECEIVERS	150	NICEWAY
	154	FLOR-S, FLOR-M
	156	PLANOTIME
	157	RECEIVERS

---

OPERA SYSTEM	158	O-VIEW, O-BOX, ONE, OX4T, INB
--------------	-----	----------------------------------

---

TAG SYSTEM	164	TTX4, TT2, TT1
------------	-----	----------------

# TOUCH SCREEN

NEW

## Touchscreen to control Nice automations and manage the NiceHome alarm system

The wireless Nice Era touchscreen can manage all home automations, thanks to remote control of:

- a maximum of 99 single controls,
- up to 10 groups of controls, to manage a number of automations of the same type simultaneously;
- up to 10 single scenarios, to manage different automations, including those associated with the alarm system.

By using Nice TT2L or TT2D miniaturised control units and/or universal receivers (es. SMX2R etc.) you can manage light, irrigation and heating (convector heaters, etc.).

Automations, groups and scenarios can be controlled in time bands thanks to the built-in weekly and hourly programmer.

Simple programming, configuration and control of the alarm system, with intuitive graphic display, built-in vocal guide and bidirectional technology.

**Built-in proximity transponder badge reader for the management of alarm system:** each individual key can be personalised for the single user and individual zones.

Thanks to the bidirectional wireless communication with the alarm system, the touchscreen displays alarm system status, indicating the status of each individual zone by means of simple icons.

### Main functions:

- Management of Nice automations with FLOR encoding: it can control up to 99 single automations divided into sun screens, gates, garages and lighting.
- Simultaneous management of the controls for blinds, shutters and sun screens automated with Nice tubular motors.
- Control of single automations, groups of automations and the execution of scenarios, with the possibility of attributing a name to each automation.
- Management of timed controls through the built-in weekly and hourly programmer.
- Four programmable buttons to control automations and/or groups and/or scenarios.
- Scenarios combined with event notifications enable the garden lights to be turned on and/or the shutters to be closed in the event of an alarm in the garden.
- Easy to update thanks to the mini-USB connector.



HSTSA1  
CHARGER BASE

HSB1  
TRANSPONDER BADGE

CODE	DESCRIPTION	PACK/PALLET
<b>HSTS2EN</b>	WIRELESS TOUCH SCREEN	1
<b>HSB1</b>	TRANSPONDER BADGES	10
<b>HSTA1</b>	CHARGER BASE FOR TOUCH SCREEN, WITH RECHARGEABLE BATTERIES INCLUDED	1

#### ACCESSORIES FOR TOTAL HOME MANAGEMENT:

CODE	DESCRIPTION	PACK/PALLET
<b>TT2N</b>	CONTROL UNIT FOR 230 Vac MOTOR WITH BUILT-IN RADIO RECEIVER	1
<b>TT2L</b>	CONTROL UNIT FOR MANAGEMENT OF 230 Vac LIGHTING SYSTEMS, WITH BUILT-IN RADIO RECEIVER	1
<b>TT2D</b>	CONTROL UNIT FOR MANAGEMENT OF 230 Vac LIGHTING SYSTEMS, WITH BUILT-IN RADIO RECEIVER AND SWITCHING MODULE	1
<b>FLOX2R</b>	UNIVERSAL RECEIVERS, 2 CHANNELS WITH BM250 MEMORY	1
<b>SMX2R</b>	UNIVERSAL RECEIVERS, 2 CHANNELS WITH 256-CODES MEMORY, PRE-WIRED	1



#### TECHNICAL SPECIFICATIONS

##### RADIO TRANSMISSION

FREQUENCY	433,92 MHz - 434,32 MHz
TIPO	DIGITAL BIDIRECTIONAL WITH HSCU2 ALARM SYSTEM
RANGE	100 m IN OPEN SPACE WITHOUT INTERFERENCE, 20 m INSIDE BUILDINGS

##### FUNCTIONS

DISPLAY	3.75" GRAPHIC 240x128 pixel, MONOCHROME BACKLIT
ON BUTTON	YES
CONFIGURABLE GROUPSI	10 CONFIGURABLE GROUPS OF SIMILAR AUTOMATIONS (SAME COMMANDS)
SCENARIOS	10 CONFIGURABLE SCENARIOS WITH COMMANDS CONTROLLING AUTOMATIONS AND ALARM ACTIVATION-DEACTIVATION
ACTIVATION TIMER	10 CONFIGURABLE
LED	BLUE - RADIO COMMUNICATION / RED - BATTERY FLAT / ORANGE - CHARGING / GREEN - FULLY CHARGED
FUNCTION BUTTONS	4 CONFIGURABLE
TRANSPONDER KEY READER	YES
MICROPHONE	YES
LOUDSPEAKER	0,5 W
VOICE RECORDER	5 MESSAGES FOR A TOTAL OF 120 S
SW UPDATING	YES BY MICRO-USB INPUT
MOVEMENT SENSOR	YES
EVENTS LOG	100

##### POWER SUPPLY

POWER SUPPLY	2 x 1.5 V AA ALKALINE BATTERIES SUPPLIED
AUTONOMY	ON AVERAGE MORE THAN A YEAR DEPENDING ON USE
SUPPLEMENTARY POWER SUPPLY	BY HSTA1 CHARGING BASE AND AA RECHARGEABLE BATTERIES CONNECTED TO THE MICRO-USB PORT

##### SYSTEM

WORKING TEMPERATURE (ENVIRONMENTAL CLASS I)	+5° C ÷ + 40° C (EN50131 ENVIRONMENTAL CLASS I)
DIMENSIONS	154x83x20 mm
WEIGHT	250 g

# ERA INTI

NEW

The colourful line of 1 and 2 channel miniaturised transmitters, available in six colours.

433.92 MHz rolling code, with management of Identity Codes and Certificates, self-learning and built-in proximity receiver; with 72 bit O-Code encoding, also compatible with receivers with Nice FLOR encoding.

**Evolved:** uses data processing and recognition systems that increase its degree of security and deliver a threefold reduction in automation response times.

**Easy memorisation, even at a distance,** thanks to Opera receivers.

There are two options for enabling a new Inti transmitter, even at a distance from the system:

- using a transmitter already programmed in the receiver, thanks to the enabling **Code exchange** between the two (figure 1);
- using the Nice O-Box connection interface; the receiver's **Certificate** is entered by just placing the new Inti next to the O-Box and following the guided procedure on a PC or PDA (figure 2).

**Safe,** if a transmitter is stolen or lost, with the O-Box the user can:

- **replace it,** maintaining the same functions as in the previous one, **disable** the old transmitter by increasing the priority level on the new Inti.

Inti can be used as keyring thanks to the lace included in the pack.

## TRANSMITTERS INTI

CODE	DESCRIPTION	PCS/PACK
INTI1Y	1 CHANNEL, 433.92 MHz, YELLOW	10
INTI2Y	2 CHANNEL, 433.92 MHz, YELLOW	10
INTI1R	1 CHANNEL, 433.92 MHz, RED	10
INTI2R	2 CHANNEL, 433.92 MHz, RED	10
INTI1L	1 CHANNEL, 433.92 MHz, LILAC	10
INTI2L	2 CHANNEL, 433.92 MHz, LILAC	10
INTI1G	1 CHANNEL, 433.92 MHz, GREEN	10
INTI2G	2 CHANNEL, 433.92 MHz, GREEN	10
INTI1B	1 CHANNEL, 433.92 MHz, BLUE	10
INTI2B	2 CHANNEL, 433.92 MHz, BLUE	10
INTI1	1 CHANNEL, 433.92 MHz, BLACK	10
INTI2	2 CHANNEL, 433.92 MHz, BLACK	10
INTIKIT	THE KIT CONTAINS: 3 TWO-CHANNEL INTI UNITS (COLOURS RED, GREEN AND BLUE) 1 OX2 RECEIVER.	

## TRANSMITTER TECHNICAL SPECIFICATIONS

	Carrier frequency	Estimated range	Encoding	Power supply	Battery life	Protection class	Dimensions Weight
INTI_Y, INTI_R, INTI_L, INTI_G, INTI_B, INTI	433.92 MHz	150 m (outdoors); 30 m (if inside buildings)*	O-Code 72 bit; rolling code	3 Vdc; lithium battery type CR2032	2 years (with 10 transmissions per day)	IP40 (use in protected environments)	30x56x9 h mm 14 g

\* Transmitter range and receiver reception capacity may be affected by any devices operating on the same frequency in the area.



**INTIKIT**  
THE KIT CONTAINS:  
3 TWO-CHANNEL INTI UNITS  
(COLOURS RED, GREEN AND BLUE)  
1 OX2 RECEIVER.



## UNIVERSAL!

**Inti, the universal control!**  
**Ideal for use in apartment blocks or multi-user systems.**

Easy and cheap to install: combined with the OX2 universal receiver, the Inti transmitter is able to control and manage any automation, including pre-installed systems.

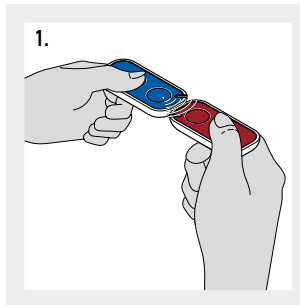

1. CODE EXCHANGE BETWEEN A MEMORIZED TRANSMITTER AND A NEW ONE, TO BE MEMORIZED.

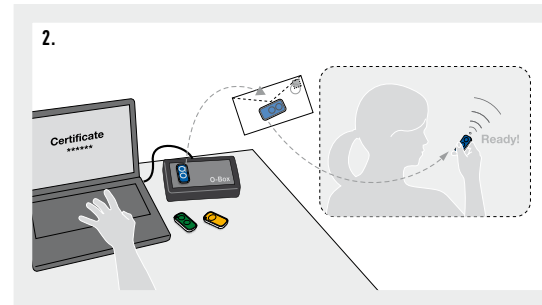

2. POSSIBLE MEMORISATION USING NICE O-BOX AND THE "CERTIFICATE"

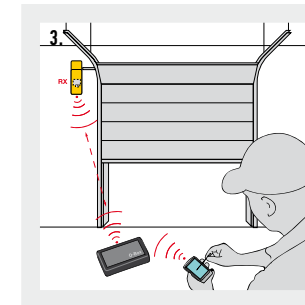

3. THE PRESENCE OF A "TRANSMITTER" IN THE OXIT, OX2T AND OX4T RECEIVERS ALLOWS RADIO CODES TO BE ACCESSED BY MEANS OF THE O-BOX MULTIFUNCTION INTERFACE.

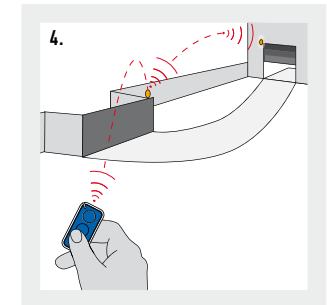

4. OXIT, OX2T AND OX4T RECEIVERS CAN BE USED AS SIGNAL REPEATERS.

# ERA ONE

NEW

The system includes 1, 2, 4 and 9 channel transmitters and prewired receivers with connector, with and without built-in transmitter.

433.92 MHz rolling code, with management of Identity Codes and Certificates, self-learning and built-in proximity receiver; with 72 bit O-Code encoding, also compatible with receivers with Nice FLOR encoding.

Available in versions with multiple input sequential encoding (Era OneC).

**Evolved:** uses data processing and recognition systems that increase its degree of security and deliver a threefold reduction in automation response times.

**Easy memorisation, even at a distance,** thanks to Opera receivers.

There are two options for enabling a new Inti transmitter, **even at a distance from the system:**

- using a transmitter already programmed in the receiver, thanks to the enabling **Code exchange** between the two (figure 1);
- using the Nice O-Box connection interface; the receiver's **Certificate** is entered by just placing the new Era One next to the O-Box and following the guided procedure on a PC or PDA (figure 2).

**Safe,** if a transmitter is stolen or lost, with the O-Box the user can:

- **replace it,** maintaining the same functions as in the previous one, **disable** the old transmitter by increasing the priority level on the new Era One.

**Extremely practical:** using the O-Box software, the Era OneC version allows whole packs of 10 devices to be programmed in a single procedure, without even opening them!

**Elegant and convenient:** the Era One transmitter can be used as a stylish, high-tech keyring or fixed to the wall or your car's dashboard with the handy support included in the pack.

**Era OneFM, ideal for use in cities or places where many devices are present.**

868.46 MHz Rolling Code transmitter line, using frequency modulation (FM), less sensitive to interference than amplitude modulation AM.

## ERA ONE TRANSMITTERS

CODE	DESCRIPTION	PCS/PACK
<b>ON1E</b>	1 CHANNEL, 433.92 MHz	10
<b>ON2E</b>	2 CHANNELS, 433.92 MHz	10
<b>ON4E</b>	4 CHANNELS, 433.92 MHz	10
<b>ON9E</b>	9 CHANNELS, 433.92 MHz	10
<b>ON1CE</b>	1 CHANNEL, 433.92 MHz, WITH MULTIPLE INPUT SEQUENTIAL ENCODING	10
<b>ON2CE</b>	2 CHANNELS, 433.92 MHz, WITH MULTIPLE INPUT SEQUENTIAL ENCODING	10
<b>ON4CE</b>	4 CHANNELS, 433.92 MHz, WITH MULTIPLE INPUT SEQUENTIAL ENCODING	10
<b>ON1EFM</b>	1 CHANNEL, 868.46 MHz	10
<b>ON2EFM</b>	2 CHANNELS, 868.46 MHz	10
<b>ON4EFM</b>	4 CHANNELS, 868.46 MHz	10
<b>ON9EFM</b>	9 CHANNELS, 868.46 MHz	10

## TRANSMITTER TECHNICAL SPECIFICATIONS

	Carrier frequency	Estimated range	Encoding	Power supply	Battery life	Protection class	Dimensions Weight
<b>ON_E, ON_CE</b>	433.92 MHz	200 m (outdoor); 35 m (if inside buildings)*	O-Code 72 bit; rolling code	3 Vdc, type CR2032 lithium battery	2 years (with 10 transmissions per day)	IP40 (use in protected environments)	44x55x10 h mm 11 g
<b>ON_EFM</b>	868.46 MHz						

\* Transmitter range and receiver reception capacity may be affected by any devices operating on the same frequency in the area.

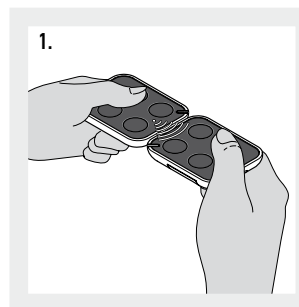

1. CODE EXCHANGE BETWEEN A MEMORIZED TRANSMITTER AND A NEW ONE, TO BE MEMORIZED.

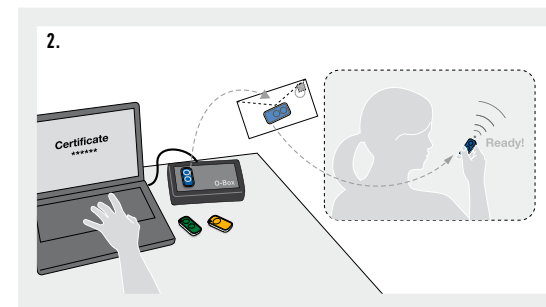

2. POSSIBLE MEMORISATION USING NICE O-BOX AND THE "CERTIFICATE".

# ERA FLOR

NEW

**1, 2 and 4 channel transmitters with a new stylish design.**

**433.92 MHz rolling code system with self-learning function.**

Also available in versions with multiple input sequential encoding (Era FlorCE).

**Absolute security:** rolling code transmission makes the transmitter impossible to clone.

**Ideal solution for the management of multi-user apartment block systems** thanks to the unique, personal code.

**Easy duplication of new transmitter close to the system** by using an authorised transmitter or directly using a key on the receiver, while a LED displays the various functions.



**Extremely practical:** using the O-Box programming unit, the Era Flor-CE version allows whole packs of 100 devices to be programmed in a single procedure, without even opening them.

The O-Box and dedicated software applications for PC and PDA allow:

- **quick, user-friendly programming** of receivers and transmitters;
- **management and printout of code list;**
- creation of individual **installation databases** (useful in multi-user systems).

**Optimal autonomy and low consumption.**

**Elegant and convenient:** the Era Flor transmitter can be used as a stylish, high-tech keyring or fixed to the wall or your car's dashboard with the handy support included in the pack.

**Total compatibility** with previous Flor series receivers (universal, universal modular and with Nice or SM connector) and with the One receivers (OX1/OXIT, OX2/OX2T and OX4T).

CODE	DESCRIPTION	PCS/PACK
<b>FLO1RE</b>	1 CHANNEL ERA FLOR TRANSMITTER	10
<b>FLO2RE</b>	2 CHANNEL ERA FLOR TRANSMITTER	10
<b>FLO4RE</b>	4 CHANNEL ERA FLOR TRANSMITTER	10
<b>FLO1RCE</b>	1 CHANNEL ERA FLOR TRANSMITTER WITH MULTIPLE INPUT SEQUENTIAL ENCODING	10
<b>FLO2RCE</b>	2 CHANNEL ERA FLOR TRANSMITTER WITH MULTIPLE INPUT SEQUENTIAL ENCODING	10
<b>FLO4RCE</b>	4 CHANNEL ERA FLOR TRANSMITTER WITH MULTIPLE INPUT SEQUENTIAL ENCODING	10

## TECHNICAL SPECIFICATIONS

Carrier frequency	Estimated range	Encoding	Power supply	Battery life	Protection class	Dimensions Weight
433.92 MHz	150/200 with tuned antenna in open spaces	52 bit digital (4.5 million billion combinations)	3 Vdc; lithium battery type CR2032	3 years (with 10 transmissions per day)	IP40 (use in protected environments)	58x86x22 h mm 55 gr

\* Transmitter range and receiver reception capacity may be affected by any devices operating on the same frequency in the area.



FLO1RE



FLO2RE



FLO4RE

# RECEIVERS

## ERA INTI, ONE, FLOR

The complete line of receivers with Opera system functions, suitable for all installation requirements:

- **with connector**, compatible with latest-generation Nice control units with SM port;
- **universal prewired**, for use with all types of control unit, for the control of any automation, lighting or irrigation system or other electric circuits.

### Maximum flexibility:

up to 1024 transmitters can be memorised.

### Convenient and practical:

the inclusion of a transmitter in the OXIT/OXITFM, OX2T/OX2TFM and OX4T receivers allows radio codes to be accessed by means of the O-Box multifunction interface even when in inaccessible positions (figure 3).

OXIT/OXITFM, OX2T/OX2TFM and OX4T receivers can be used as signal repeaters to increase the operating distance between transmitters and other One series receivers (figure 4).

**Secure use**, thanks to the 3 password-protected levels.

The **O-Box** and dedicated software applications for PC and PDA allow:

- **quick, user-friendly programming** of receivers and transmitters;
- **management** and printout of **code list**;
- creation of **individual installation databases** (useful in multi-user systems).

### 433.92 MHz RECEIVERS, WITH OPERA SYSTEM FUNCTIONS

#### WITH CONNECTOR

CODE	DESCRIPTION	PCS/PACK
OXI	4 CHANNELS, WITHOUT BUILT-IN TRANSMITTER	1
OXIT	4 CHANNELS, WITH BUILT-IN TRANSMITTER	1

#### PRE-WIRED UNIVERSAL

OX2	2 CHANNELS, WITHOUT BUILT-IN TRANSMITTER	1
OX2T	2 CHANNELS, WITH BUILT-IN TRANSMITTER	1
OX4T	4 CHANNELS, WITH BUILT-IN TRANSMITTER	1



OXI, OXIT



OX2, OX2T



OX4T  
See page 163

### 868.46 HZ RECEIVERS, WITH OPERA SYSTEM FUNCTIONS

#### WITH CONNECTOR

CODE	DESCRIPTION	PCS/PACK
OXIFM	4 CHANNELS, WITHOUT BUILT-IN TRANSMITTER	1
OXITFM	4 CHANNELS, WITH BUILT-IN TRANSMITTER	1

#### PRE-WIRED

OX2FM	2 CHANNELS, WITHOUT BUILT-IN TRANSMITTER	1
OX2TFM	2 CHANNELS, WITH BUILT-IN TRANSMITTER	1



OXIFM, OXITFM



OX2FM, OX2TFM

## MULTI-FUNCTION INTERFACE

CODE	DESCRIPTION	PCS/PACK
<b>OBOX2</b>	DUAL BAND INTERFACE, FOR 433.92/868.46 MHz DEVICES, COMPLETE WITH SOFTWARE, SUPPLIED WITH USB CONNECTION CABLE.	1
<b>OBOX2B</b>	DUAL BAND INTERFACE, FOR 433.92/868.46 MHz DEVICES, COMPLETE WITH SOFTWARE, WITH USB CONNECTION CABLE AND BUILT-IN BLUETOOTH MODULE.	1



O-BOX

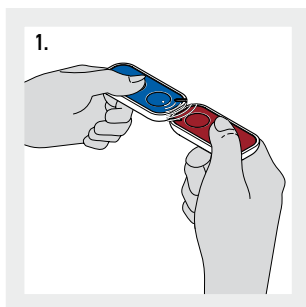

1. CODE EXCHANGE BETWEEN A MEMORIZED TRANSMITTER AND A NEW ONE, TO BE MEMORIZED.

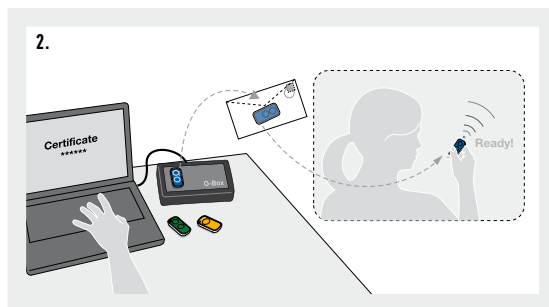

2. POSSIBLE MEMORISATION USING NICE O-BOX AND THE "CERTIFICATE".

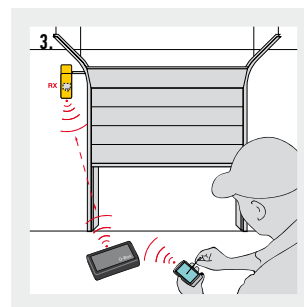

3. THE PRESENCE OF A "TRANSMITTER" IN THE OX1T, OX2T AND OX4T RECEIVERS ALLOWS RADIO CODES TO BE ACCESSED BY MEANS OF THE O-BOX MULTIFUNCTION INTERFACE.

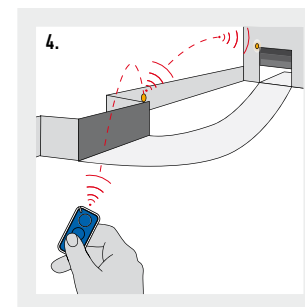

4. OX1T, OX2T AND OX4T RECEIVERS CAN BE USED AS SIGNAL REPEATERS.

## RECEIVER TECHNICAL SPECIFICATIONS

	Reception frequency	Transmission frequency	Input impedance	Sensitivity	Encoding	Number of channels	Relay contact	Power supply	Absorption	Protection class	Dimensions Weight	
<b>OX1</b>	433.92 MHz	-	52 Ohm	>0.5 $\mu$ V for signals with successful outcomes	O-Code, FloR, Flo	4 (15 on BUS T4)	-	5 Vdc	30 mA (max)	IP 30	50x19x45 h mm, 20 g	
<b>OX1T</b>		433.92 MHz				2	max 0.5 A 50 V (NA)	from 12 to 28 Vdc/Vac	80 mA (max) with relays active			
<b>OX2</b>		-				433.92 MHz	4 relays with NO and NC contacts, voltage-free	5 A - 250 V	110 $\pm$ 240 Vac 50/60 Hz	80 mA	IP 44 (with container intact)	128x112x43 h mm, 260 g
<b>OX2T</b>												
<b>OX4T</b>												
<b>OX1FM</b>	868.46 MHz	-	52 Ohm	>0.8 $\mu$ V for signals with successful outcomes	O-Code	4 (15 on BUS T4)	-	5 Vdc	30 mA (max)	IP 30	50x19x45 h mm, 20 g	
<b>OX1TFM</b>		868.46 MHz				2	max 0.5 A 50 V (NA)	from 12 to 28 Vdc/Vac	100 mA (max) with relays active			
<b>OX2FM</b>		-				868.46 MHz	4 relays with NO and NC contacts, voltage-free	5 A - 250 V	110 $\pm$ 240 Vac 50/60 Hz	80 mA	IP 44 (with container intact)	128x112x43 h mm, 260 g
<b>OX2TFM</b>												

# NICEWAY

## Modular control system

to manage the range of Nice automations from any point within the home.

### Modular

The NiceWay system is based on a number of transmitter modules that can be placed in five different holder models to create a flexible range of made-to-measure solutions.

Although the modules, available from 1 to 80 groups or 240 channels, are very small in size, they are extremely easy to operate.

### Advanced and compatible

Frequency of 433.92 MHz, 52 Bit Rolling Code with (over 4.5 million of billion combinations); self-learning function.

Compatible with the 433.92 MHz Nice Ergo, Plano, FloR and VeryVR systems (Flo and Smilo with WM240C and WM080G).

Estimated range: 200 m in a free field, 35 m indoors.

Extended battery life (3 V lithium battery).

### All the NiceWay solutions

The 240 channel module with display, which controls 80 groups and 70 multi-groups, is ideal for the management of sophisticated systems. All the awnings, roller shutters and gates, as well as the office, home and hotel irrigation and lighting systems in just 14 g and 16 cm<sup>2</sup>!

### Made-to-measure

To protect the electronic parts from dirt and damp, the rubber function buttons are incorporated in the actual body of the control modules.

NiceWay can be used anywhere in the home, in the garage, the living room, the kitchen as well as the bathroom.

### Professional

For a more professional and practical use, the system can be programmed by means of the handy Nice palmtops.

## TECHNICAL SPECIFICATIONS











POWER SUPPLY (Vdc)	: 3 V WITH 1 LITHIUM BATTERY CR2032
BATTERY LIFE	: > 2 YEARS WITH 10 EVENTS/DAY
FREQUENCY	: 433.92 MHz ± 100 KHz
RADIATED POWER	: ESTIMATED AT APPROX. 1 mW
PROTECTION RATING (IP)	: 40
ESTIMATED RANGE	: 200 m IN A FREE FIELD, 35 m INDOORS
CODING	: 52 BIT ROLLING CODE
OPERATING TEMPERATURE (°C MIN. MAX.)	: -20 ÷ +55
DIMENSIONS (mm)	: 41x41x10
WEIGHT (g)	: 14

## The heart of the NiceWay system

The 1, 3, 6 and 9-channel modules for the control of single automations, groups or multi-groups: awnings, roller shutters, rolling doors, gates, industrial and garage doors, barrier gate operators, lighting and irrigation systems.



1. The transmitter module 2. The module holder cover 3. Wall or table shockproof holder  
4. Table shockproof holder 5. Squared wall plate 6. Rectangular wall plate.

MODULE	CODE	DESCRIPTION	PC./PACK
<b>MODULES TO CONTROL STEP-BY-STEP AUTOMATION SYSTEMS</b>			
	<b>WM001C</b>	SINGLE CHANNEL MODULE TO CONTROL 1 AUTOMATION SYSTEM	10
	<b>WM003C</b>	THREE CHANNEL MODULE TO CONTROL 3 STEP-BY-STEP AUTOMATION SYSTEMS	1
	<b>WM009C</b>	NINE CHANNEL MODULE TO CONTROL 9 STEP-BY-STEP AUTOMATION SYSTEMS	1
Memorizing radio controls in Mode I: ON - OFF Mode II: ON/OFF - HOLD TO RUN - TIMER1 - TIMER2 (for the Screen products MOD0 II programming)			
<b>HYBRID MODULE TO CONTROL STEP-BY-STEP AND OPEN-STOP-CLOSE AUTOMATION SYSTEMS</b>			
	<b>WM003C1G</b>	MODULE TO CONTROL 3 STEP-BY-STEP AND 1 OPEN-STOP-CLOSE AUTOMATION SYSTEMS	1
<b>MODULES TO CONTROL OPEN-STOP-CLOSE AUTOMATION SYSTEMS</b>			
	<b>WM001G</b>	MODULE TO CONTROL 1 OPEN-STOP-CLOSE AUTOMATION SYSTEM EITHER INDIVIDUALLY OR IN MULTI-GROUP MODE	1
	<b>WM002G</b>	MODULE TO CONTROL 2 OPEN-STOP-CLOSE AUTOMATION SYSTEMS EITHER INDIVIDUALLY OR IN MULTI-GROUP MODE	1
	<b>WM003G</b>	MODULE TO CONTROL 3 OPEN-STOP-CLOSE AUTOMATION SYSTEMS EITHER INDIVIDUALLY OR IN MULTI-GROUP MODE	1
	<b>WM006G</b>	MODULE TO CONTROL 6 OPEN-STOP-CLOSE AUTOMATION SYSTEMS EITHER INDIVIDUALLY OR IN MULTI-GROUP MODE	1
	<b>WM004G</b>	MODULE TO CONTROL 4 OPEN-STOP-CLOSE AUTOMATION SYSTEMS EITHER INDIVIDUALLY OR IN MULTI-GROUP MODE AND SUN SENSOR ACTIVATION COMMAND	1
<b>MULTI-CHANNEL DISPLAY MODULE</b>			
	<b>WM080G</b>	MODULE TO CONTROL 80 OPEN-STOP-CLOSE AUTOMATION SYSTEMS EITHER INDIVIDUALLY OR IN MULTI-GROUP MODE AND SUN SENSOR ACTIVATION COMMAND	1
	<b>WM240C</b>	MODULE TO CONTROL 240 STEP-BY-STEP AUTOMATION SYSTEMS EITHER INDIVIDUALLY OR IN MULTI-GROUP MODE	1

## NICE DESIGN

Sophisticated shock-proof materials, immaculate finish, and essential design: wear, comfort and ease are guaranteed by the internationally renowned and prize-winning Nice design.

The choice of discreet or personalised solutions is vast thanks to the wide choice of colours and finishes.



# STONE

## NiceWay - Stone Portable and table-top supports.

### Fetching and practical

With Stone the radio control device becomes even more functional and catching.

In shock-proof rubber to completely protect the transmitting module, fully directional for greater reception, Stone is available in neutral or bright colours so as to perfectly blend into modern or elegant homes.

### Comfortable anywhere

Resistant to the most violent of shocks and garden humidity, Stone is always easy to find, be it on the living room or office coffee table, on the kitchen worktop, in the bathroom or on the side of the pool.



CODE	DESCRIPTION	PC/PACK
<b>WEW</b>	TABLE SHOCKPROOF HOLDER, WHITE	10
<b>WET</b>	TABLE SHOCKPROOF HOLDER, NEUTRAL TRANSPARENT	10
<b>WEO</b>	TABLE SHOCKPROOF HOLDER, ORANGE	10



**WEW**



**WET**



**WEO**

# ONDO

## NiceWay - Ondo Portable, wall mounted and table-top supports.

### Portable, from table to wall

Ondo is the versatile NiceWay line support; the wall support with its simple magnetic fixing system, transforms Ondo from a comfortable portable transmitter to an inconspicuous wall plate.

Ondo, made in a shiny dirt-resistant plastic, has a rubber lower section to improve grip and prevent slipping when used on surfaces.

The transmitter module can be inserted so that Ondo can be used both in width and in length to increase the personalisation possibilities.



CODE	DESCRIPTION	PC/PACK
<b>WAX</b>	TABLE HOLDER, WHITE PLASTIC AND ICE BLUE RUBBER	10
<b>WWW</b>	MAGNETIC WALL SUPPORT FOR WAX	10



**WAX**



**WWW**



# OPLA

## NiceWay Wall plaques.

### Elegant, discreet and functional

Extremely slim - as is the plate itself - the transmitter inserted into the Opla wall plate permits to inconspicuously and fetchingly add additional control points without having to perform any building operations.

The NiceWay Opla wall plates are available in the square Opla-S version and the rectangular Opla-R version and in many different colours.



CODE	DESCRIPTION	PC/PACK
<b>WSW</b>	SQUARED WALL PLATE, WHITE	10
<b>WSB</b>	SQUARED WALL PLATE, BLACK	10
<b>WSA</b>	SQUARED WALL PLATE, ALUMINIUM	10
<b>WSG</b>	SQUARED WALL PLATE, GRAPHITE	10
<b>WST</b>	SQUARED WALL PLATE, NEUTRAL TRANSPARENT	10
<b>WSS</b>	SQUARED WALL PLATE, SEAWATER	10

CODE	DESCRIPTION	PC/PACK
<b>WRW</b>	RECTANGULAR WALL PLATE, WHITE	10
<b>WRB</b>	RECTANGULAR WALL PLATE, BLACK	10
<b>WRA</b>	RECTANGULAR WALL PLATE, ALUMINIUM	10
<b>WRG</b>	RECTANGULAR WALL PLATE, GRAPHITE	10
<b>WRT</b>	RECTANGULAR WALL PLATE, NEUTRAL TRANSPARENT	10
<b>WRS</b>	RECTANGULAR WALL PLATE, SEAWATER	10



WSW, WRW

WSB, WRB

WSA, WRA

WSG, WRG

WST, WRT

WSS, WRS

# GO

## NiceWay Mini cover.

### Go Nice!

Snugly in the pocket!

Every NiceWay transmitter really becomes portable with the Go support: the maximum performance to manage up to 240 channels from anywhere and with the maximum compactness.

Made of shock-proof rubber, in different and exclusive colours, Go protects the module from the most severe of knocks.

Go can be hung anywhere and can also be used as a key-ring thanks to the tie that is included in the pack.



CODE	DESCRIPTION	PC/PACK
<b>WCF</b>	MINI COVER, FERN GREEN	10
<b>WCG</b>	MINI COVER, GRAPHITE	10
<b>WCI</b>	MINI COVER, ICE BLUE	10
<b>WCO</b>	MINI COVER, ORANGE	10



WCF

WCG

WCI

WCO

# FLOR-S

## Radio-controls with 4.5 million billion combinations.

433.92 MHz rolling code system with self-learning function and sequential code for multiple insertion (Flor-sc).

The ideal solution for the management of multi-use systems with a unique and personal code: the self-learning receivers can receive and store up to 1,020 codes.

Using the BUPC palm-top device, the **Flor-sc model** makes it possible to memorise entire packs in one operation, without even having to open them.



Rolling code transmission: **absolutely secure** because it's impossible to clone the transmitter.

**Self-learning function:** the codes can be entered at a distance with an authorised transmitter or with a programming button on the receiver while a LED displays the different functions.

**A drop in consumption** but greater independence. Low battery warning via Leds.

### The Flor-s system includes:

**Transmitters** with 1, 2, 4 channels.

Universal **receivers** with 1 or 2 channels, universal modular, plug-in or for universal outdoors IP53, with step-by-step, timer and anti-burglar functions.

The **aerial** can be incorporated in the Lucy flashing light or in the outdoor IP53 receiver, or fixed with a bracket.

CODE	DESCRIPTION	PC/PACK
<b>FLO1R-S</b>	1 CHANNEL	10
<b>FLO2R-S</b>	2 CHANNELS	10
<b>FLO4R-S</b>	4 CHANNELS	10
<b>FLO1R-SC</b>	1 CHANNEL WITH SEQUENTIAL CODE FOR MULTIPLE INSERTION	10
<b>FLO2R-SC</b>	2 CHANNELS WITH SEQUENTIAL CODE FOR MULTIPLE INSERTION	10
<b>FLO4R-SC</b>	4 CHANNELS WITH SEQUENTIAL CODE FOR MULTIPLE INSERTION	10

### TECHNICAL SPECIFICATIONS

CARRIER FREQUENCY	: 433.92 MHz ±100 KHz
ESTIMATED RANGE	: 150 - 200 m WITH A TUNED AERIAL IN A FREE AREA
CODING	: DIGITAL 52 BIT (4.5 MILLION BILLION COMBINATIONS)
POWER SUPPLY	: 12 Vdc + 20% - 40% WITH 23 A BATTERY
AVERAGE ABSORPTION (mA)	: 25
DIMENSIONS (mm)	: 72x40x15 h



FLO1R-S, FLO1R-SC



FLO2R-S, FLO2R-SC



FLO4R-S, FLO4R-SC

# FLOR-M

The BUPC and OBOX software make it possible to memorise entire 100 piece packs in one operation, without even having to open them!

**Flor-m is recognised by both FloR receivers and MyMoon transponder readers.**

**Bimodal radio control unit with incorporated transponder, 4.5 million billion combinations.**  
433.92 MHz rolling-code system with recognition and sequential code for multiple insertion.

The **Flor-m transmitters transponders** offer new options for controlling entries, by uniting several commands in a single product.  
Available in the 2 and 4 channel versions, the features of these models are identical to those of the Flor-sc transmitters and **programmable and reprogrammable Mocardp: a Nice exclusive.**



CODE	DESCRIPTION	PC/PACK
<b>FLO2R-M</b>	2 CHANNELS SEQUENTIAL CODE FOR MULTIPLE INSERTION AND INCORPORATED TRANSPONDER TECHNOLOGY	10
<b>FLO4R-M</b>	4 CHANNELS SEQUENTIAL CODE FOR MULTIPLE INSERTION AND INCORPORATED TRANSPONDER TECHNOLOGY	10

## TECHNICAL SPECIFICATIONS

CARRIER FREQUENCY	: 433.92 MHz $\pm$ 100 KHz
ESTIMATED RANGE	: 150 - 200 m WITH A TUNED AERIAL IN A FREE AREA
ANTI-CRUSHING DISTANCE (CM)	: 3 $\div$ 5
CODING	: 52 BIT DIGITAL (4.5 MILION BILLION COMBINATIONS)
POWER SUPPLY	: 12 Vdc + 20% - 40% WITH 23 A BATTERY
AVERAGE ABSORPTION (mA)	: 25
DIMENSIONS (mm)	: 72x40x15 h



FLO2R-M



FLO4R-M

# PLANOTIME

**Radio-controlled week programmable timer to manage up to 6 automation units for 100 events / week.**

**Ultra-thin and easy to install**, thanks to the fully recessed wall support. Ergonomic design user-friendly feature large energy-saving LCD display showing date, time, groups, movement, status and functions.

**Frequencies 433.92 MHz, 52 bit Rolling Code generates over 4.5 million of billion combinations; self-learning function.**

Designed to dialogue with the **FloR** systems, it enables users

to manage other kinds of automatism (on condition that they are controlled by receivers from the FloR series) such as gates, garages and so on.

**Estimated range: 200 m outdoors, 25 m indoors.**

#### Exclusive functions:

- **“random”**, enables the user to set casual opening and closing times within a preset period of time, in order to pretend someone is at home when s/he is actually away on holiday;
- **“nicetime”** enables the user to interrupt the automatic cycle to clean the window;
- **sun On/Off** this enables to activate or deactivate the sun and rain sensor linked if installed;
- **easy program**: it makes programming the opening and closing manoeuvres child's play.  
Once automatic operation has been set, Planotime will record all the manoeuvres made during the week, and repeat them during the following weeks.



CODE	DESCRIPTION	PC/PACK
PLANOTIME	WALL-MOUNTED RADIO-CONTROL TIMER WITH LCD GRAPHIC DISPLAY. CAN MANAGE UP TO 6 AUTOMATION UNITS AND 100 EVENTS / WEEK. DESIGNED YTO DIALOGUE WITH THE FLOR SERIES RECEIVERS	1

#### TECHNICAL SPECIFICATIONS

POWER SUPPLY (BATTERY LIFE)	: 3 V WITH 1 LITHIUM BATTERY CR2450 (2 YEARS WITH 10 EVENTS/DAY)
FREQUENCY	: 433.92 MHz ± 100 KHz
RADIATED POWER	: ESTIMATED AT APPROX. 1 mW
ESTIMATED RANGE	: 25 m IN INTERIORS, 200 m IN FREE SPACE
CODING	: 52 BIT 4.5 MILLION BILLION COMBINATIONS
CLOCK RESOLUTION	: 1 MINUTE
CLOCK PRECISION	: ± 150 SECOND/YEAR
NO. EVENTS/WEEK	: 100
OPERATING TEMP. (°C MIN. MAX.)	: -20 ÷ +55
DIMENSIONS (mm)	: 80x80x12 h
WEIGHT (g)	: 75

# RECEIVERS

## NICEWAY, FLOR, PLANOTIME

**Universal receivers** with 1 or 2 channels, **universal modular**, Nice or SM (SMXI) **plug-in** connector **or for universal outdoors IP53**, with step-by-step, timer and anti-burglar functions.

The FloR system can be interfaced with the BUPC palm-top devices for an easy programming and management of the codes.

**Management of multi-user system** through the unique, personal code: the recognition receivers can receive and memorise up to 63 codes with BM250, 255 with BM1000 and 1020 when the modular receiver is equipped with 4 memory cards.

**Memorisation:** a particular receiver output can be associated to each transmitter key (e.g. key 3 TX= output 1 RX).

**The aerial** can be incorporated in the Lucy flashing light or in the universal outdoor IP53 receiver, or fixed with a bracket.

### RECEIVERS

CODE	DESCRIPTION	PC/PACK
<b>Universal</b>		
FLOX2R	2 CHANNELS WITH BM250 MEMORY	1
<b>Universal IP53 for outdoors</b>		
FLOXB2R	2 CHANNELS WITH BM250 MEMORY FOR ABKIT	1
<b>With Nice plug-in</b>		
FLOXI2R	2 CHANNELS WITH BM250 MEMORY	1
<b>With SM plug-in</b>		
SMXI	UP TO 4 CHANNELS WITH 256-CODES MEMORY	1
<b>Universal SM pre-wired</b>		
SMX2R	2 CHANNELS WITH 256-CODES MEMORY, PRE-WIRED	1
<b>Universal modular</b>		
FLOXMR	4 CHANNELS WITH AN MXD CHANNEL MODULE AND BM1000 MEMORY, 24 V	1
FLOXM220R	4 CHANNELS WITH AN MXD CHANNEL MODULE AND BM1000 MEMORY, 230 Vac	1



### ACCESSORIES

#### Memory card

CODE	DESCRIPTION	PC/PACK
BM250	63 CODES MEMORY FOR FLOR RECEIVERS	5
BM1000	255 CODES MEMORY FOR FLOR RECEIVERS	5

#### Channel units for the modular receivers FloxMR and FloXMR220R

CODE	DESCRIPTION	PC/PACK
MXD	IMPULSIVE	4
MPX	STEP-BY-STEP	2
MXT	ADJUSTABLE TIMER FROM 3 SECONDS TO 5 MINUTES	2

#### Professional, tuned directional aerial

CODE	DESCRIPTION	PC/PACK
ABF	BRACKET MOUNTED	1
ABFKIT	CAN BE INCORPORATED IN THE FLOXB2R RECEIVERS AND IN LUCY FLASHING LIGHT	1

#### Batteries

CODE	DESCRIPTION	PC/PACK
B12V-D	12 V ALKALINE BATTERY FOR FLO1R-S/SC, FLO2RE/SC/M AND FLO4R-S/SC/M	50
B3VB	3 V LITHIUM BATTERY FOR PLANOTIME	25

#### Programming unit

CODE	DESCRIPTION	PC/PACK
BUPC	PROGRAMMING AND CODE CONTROL UNIT FOR THE FLOR, COMPLETE WITH PC CONNECTING CABLE, COMMUNICATION SOFTWARE, CONNECTORS FOR CLONING TRANSMITTERS AND ADVANCED CODE MANAGEMENT FUNCTIONS	1

### TECHNICAL SPECIFICATIONS

	Carrier frequency (MHz)	Reception frequency (Ohm)	Sensitivity	Power supply	Absor. when quiescent	Decoding	Number of channels	Relay contact	Dimensions (mm)
FLOX2R	433.92 SAW controlled	52	> 0.5 $\mu$ V for a good signal	from 12 to 28 Vac - dc	15 mA	52 digital bits (4.5 million billion comb.)	2	normally open max. 0.5 A 50 Vac	98x41x25 h
FLOXB2R									105x68x32 h
FLOXI2R								67x34x18 h	
FLOXMR				230 Vac $\pm$ 10%	2 VA		up to 4	118x54x148 h	
FLOXM220R				5 Vdc	-		4	50x18x46 h	
SMXI	433.92 quartz controlled			from 12 to 28 Vac - dc	10 mA		2	normally open max. 0.5 A 50 Vac	86x57x22 h
SMX2R									

### TECHNICAL SPECIFICATIONS

	Reception frequency (MHz)	Impedance (Ohm)	Bracket	Cablec
ABF	433.92	50	stainless steel	RG 58
ABFKIT			-	-
	Power supply	Communication	Consumption (mA)	Dimensions (mm)
BUPC	9 V internal battery inside 12 Vdc external source	interface RS232 standard, 9600Bps N,8 1	10	210x100x25 h

# OPERA

## Opera Control, advanced management of automation systems also at a distance.

The innovative Opera system enables the installer to manage, program and control automation systems, also remotely, simply and safely, with significant savings in time.

The **Opera** system comprises transmitters and **One** series receivers, the O-Box connection interface and the communication **software "O-View Software Suite"** and **"O-Box Software Suite"**.

All components communicate via **BUS T4** or the new **O-Code** Rolling Code system, making transmissions safer and reducing automation response times.

**Nice Opera** simplifies the installer's work, making for easier programming, and enabling access to all control panel parameters to adapt the system to all requirements. No specific procedures needed for each product: single programming mode with intuitive menus, with no need to consult instructions.

**Constantly efficient assistance for all customers:** Simplifies system programming by means of the O-View multifunction display which when connected directly to the control panels compatible with the Opera system via BUS T4, enables full access to the system functions, for practical, rapid and advanced programming.

**BUS T4** is the innovative communication protocol that enables you to create extensive networks of compatible automation systems, managing them from a single point via O-View.

Device management can be protected by two password levels. By interfacing the system with the PC, you can control a complex automation system such as those found in densely frequented buildings (hospitals, hotels, companies, etc.).

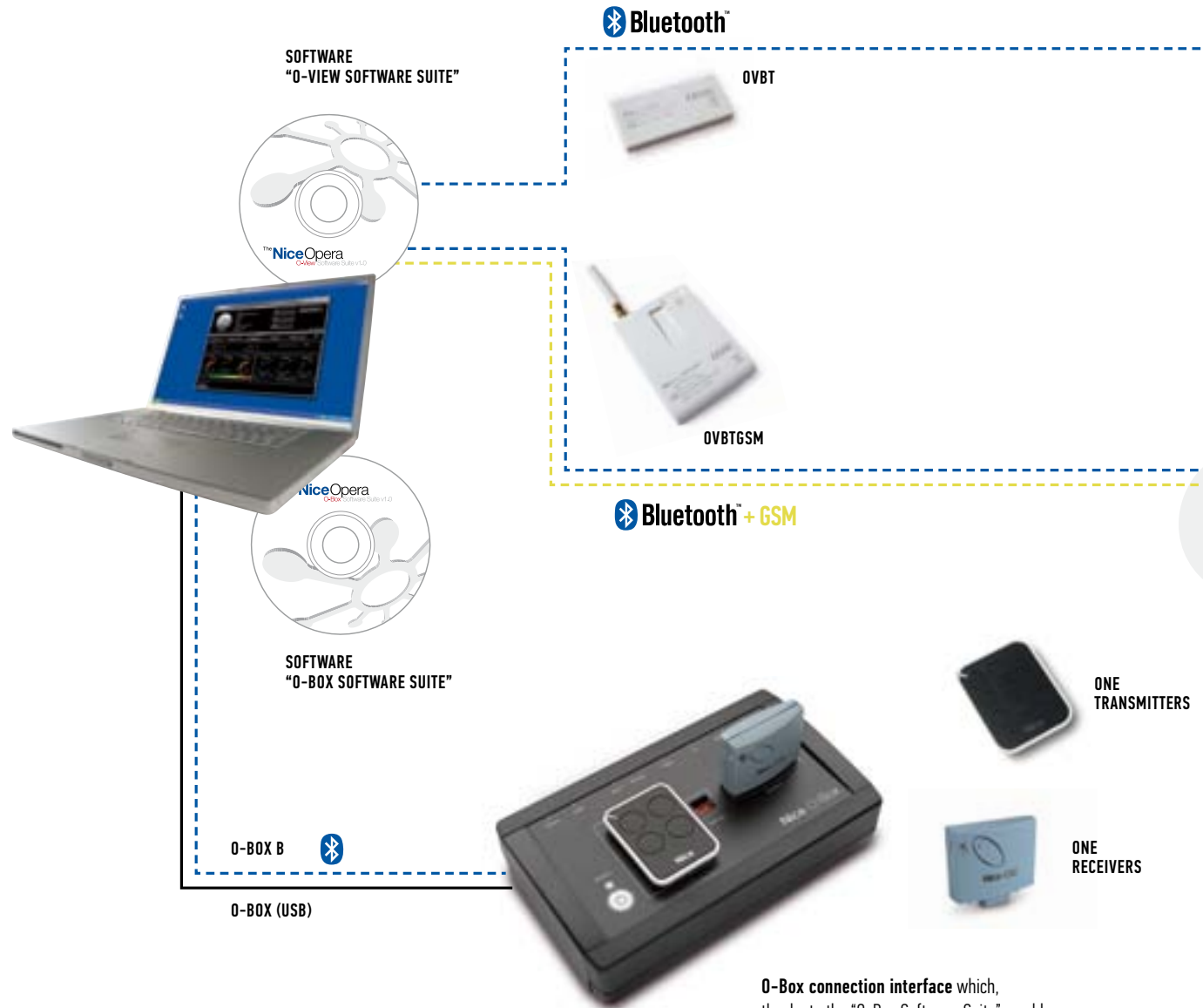

**O-Box connection interface** which, thanks to the "O-Box Software Suite", enables the configuration and programming of all Nice control devices, from the PC or PDA.



<<< BUS T4

**O-View, multifunction display**

Unit for control, programming and diagnostics for devices equipped with BUS T4 connection, on site or remotely via GPRS thanks to the connection with your PDA, Smartphone or PC.

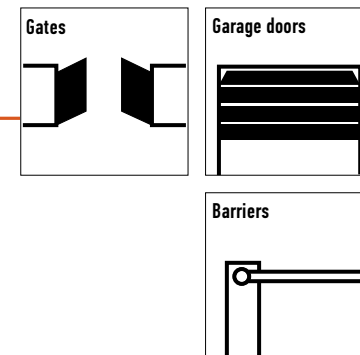

<<< BUS T4

**OX4T universal 4-channel receiver**

with built-in transmitter. For remote control of any automation, irrigation and lighting systems or other electrical circuits.



**for Nice Motors not designed for**

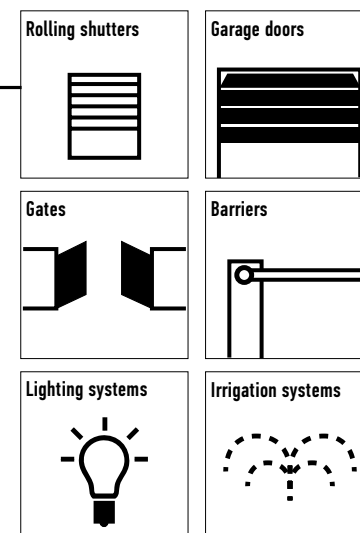

Opera

# O-VIEW

OPERA

**Unit for control, programming and diagnostics for devices equipped with BUS T4 connection, on site or remotely via GPRS thanks to the connection with your PDA, Smartphone or PC.**

**Advanced management:** O-View is connected directly to the compatible control unit via a BUS T4 cable (supplied). By connecting O-View permanently to a control unit or group of control units via BUS T4, a network can be created for local or remote centralised management.

**Simple programming mode** with intuitive menus valid for each product, with no need to consult the specific instructions.

O-View powers up and automatically recognises all devices on the network as soon as it is connected, displaying only the specific parameters of the device on which to intervene.

In the case of several devices on the network the BUS T4 address is identifiable by means of a text label personalised as required, enabling rapid recognition of the associated device.

**Programmable:** thanks to the built-in clock, it is also possible (with integrated backup battery) to program delivery of commands at a set time, for example to automate opening and closing of complex industrial and commercial systems or for the creation of "scenarios".

A practical wall-mounted support supplied.

**Safe:** two password-protected levels (for the user and the installer).

**Practical:** O-View is your portable office, and can be connected just when programming or for maintenance, or can be installed permanently on site to exploit all the benefits of local or remote centralised management.



OVBT

OVBTGSM

O-VIEW SOFTWARE SUITE

CODE	DESCRIPTION	PC./PACK
<b>OVVIEW</b>	UNIT FOR CONTROL, PROGRAMMING AND DIAGNOSTICS OF DEVICES EQUIPPED WITH BUS T4 CONNECTION	1
<b>OVBT</b>	BLUETOOTH MODULE FOR O-VIEW AND "O-VIEW SOFTWARE SUITE" APPLICATION FOR PC, PDA OR SMARTPHONE	1
<b>OVBTGSM</b>	GSM MODULE FOR O-VIEW AND "O-VIEW SOFTWARE SUITE" APPLICATION FOR PC, PDA OR SMARTPHONE	1

## TECHNICAL SPECIFICATIONS

GRAPHIC INTERFACE	: LCD DISPLAY 128x64 DOTS (46x29 mm); 2.2"
OPERATOR INPUT DEVICE	: JOYPAD WITH 5 + 2 KEYS
DISPLAY/KEY LIGHTING	: WHITE LIGHT
TIME AND DATE DISPLAY	: WITH BACKUP BATTERY (MIN. LIFETIME 10 YEARS)
MAXIMUM NUMBER OF COMMANDS PER HOUR	: 64
EVENT LOG	: STORAGE CAPACITY 400 EVENTS
CONNECTION CABLE LENGTH (m)	: 2 (CABLE SUPPLIED); 700 (OTHER CABLE)
POWER SUPPLY	: SUPPLIED BY DEVICES ON BUS T4 NETWORK
ABSORBED CURRENT (mA)	: MAX. 20 (WITHOUT ACCESSORIES)
INSULATION	: CLASS III
HOUSING PROTECTION RATING (IP)	: 20
WORKING TEMP. (°C MIN/MAX)	: FROM -20° TO +55°
DIMENSIONS (mm)	: 107x61x20 h (WITH WALL-MOUNTED SUPPORT: 125x70x32 h)
WEIGHT (g)	: 75 (WITHOUT CABLE)

## ACCESSORIES

CODE	DESCRIPTION	PC./PACK
<b>OVA1</b>	CLAMP FOR FITTING CONNECTORS RJ14	1
<b>OVA2</b>	CONNECTORS RJ14, TYPE 6/4, FOR FLAT 4-WIRE CABLE	10
<b>OVA3</b>	RJ14 SPLITTERS, TYPE 6/4, FOR CASCADE CONNECTION OF DEVICES ON BUS T4 NETWORK	5
<b>OVA4</b>	FLAT 4-WIRE CABLE FOR CONNECTION OF DEVICES ON BUS T4 NETWORK, LENGTH 100 m	1



OVA1

OVA2

OVA3

OVA4



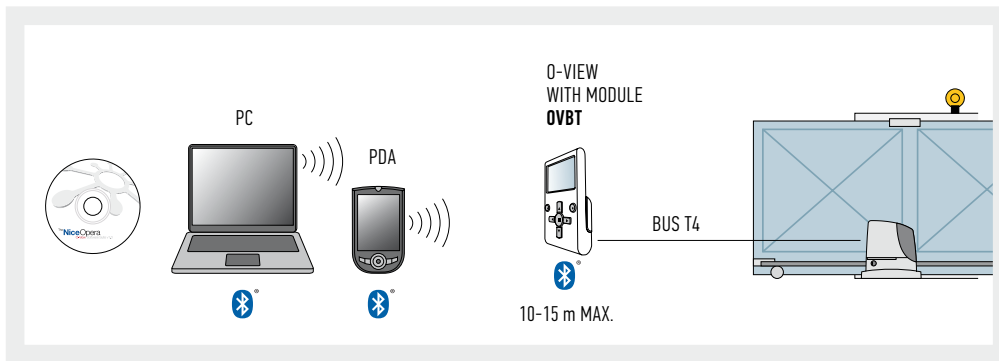

**OVBT**  
**Bluetooth connection module for O-View interface.**  
 "O-View Software Suite" enables connection via PC or PDA to O-View in the vicinity of the system, to intervene on the control units on the BUS T4 network. Maximum connection distance 15 m.

**O-VIEW SOFTWARE SUITE**

This application, supplied with OVBT and OVBTGSM, as well as expanding the functions of O-View enables the creation of a database of installations with personal data of clients and configurations of each system, even on more complex versions.

There are two versions of software: "O-View Desktop" designed for installation on a PC and "O-View Mobile" which enables use of the functions of the desktop version on a smaller screen of a PDA or Smartphone.

**By connecting to the site [www.nice-service.com](http://www.nice-service.com) users can download the constantly updated firmware and software versions.**

The interface of "O-View Software Suite" has been specially designed to enable rapid access to all parameters of the connected devices without the need for physical access, as well as quick diagnostics of malfunctions by consulting the event log, all the most practical and intuitive way possible.

The O-View control function has been expanded: in just one PC screen, all applications connected via BUS T4 can be controlled.

**Minimum requirements**

- O-View Mobile version for PDA palmtop:**
- Processor: (300 MHz) Recommended by Nice: (> 300 MHz)
  - RAM: 64 MB Recommended by Nice: 128 MB
  - Storage memory: 5 MB Recommended by Nice: 20 MB
  - Operating system: Windows® Mobile 2003 Recommended by Nice: Windows® 5.0
  - Connection: Bluetooth®
  - Graphics resolution: 240 x 320, 256 colours
  - PC with: CD-Rom (required for software installation on palmtop).

- O-View Desktop version for PC:**
- Processor: type AMD®/Intel® (500 MHz) Recommended by Nice: type AMD®/Intel® (1 GHz)
  - RAM: 128 MB Recommended by Nice: 256 MB
  - Free space on disk: 280 MB Recommended by Nice: 512 MB
  - Operating system: Windows® 98 SE or later Recommended by Nice: Windows® 2000 or later up to Win 7
  - Connection: Bluetooth®
  - Graphics resolution: 800 x 600, 256 colours
  - Disk drive: CD-Rom (required for installation).

Note – software installation includes installation of the program Microsoft® .NET Framework Redistributable 2.0.

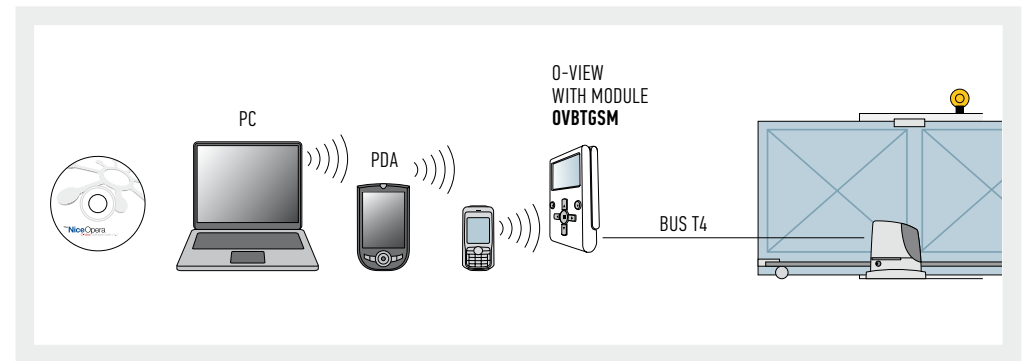

**OVBTGSM**  
 In addition to the benefits of the OVBT module, the automation or network of automations can now be **controlled via GSM** by connecting O-View to the system via BUS T4.

A GPRS connection also enables connection via the Internet to O-View to obtain all management functions offered by the software from any location with no need for presence on site.

The user can remotely control the automation via GSM, from any of the enabled numbers, and check status, such as opening a gate by means of a phone call or by sending 4 different controls via SMS text message, with the security offered by entry of a unique password.

**INB, the Nice control interface** that enables communication between the systems Nice Bus (TTBus and BusT4) and MyHome of BTicino (SCS).

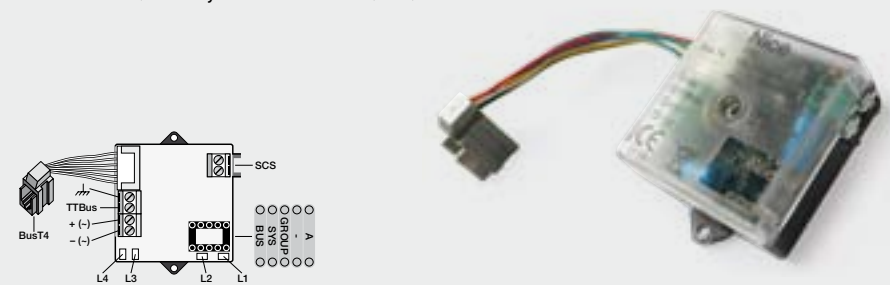

CODE	DESCRIPTION	PC/PACK
INB	COMMUNICATION INTERFACE BETWEEN BTICINO BUS (SCS) AND NICE BUS (TTBUS AND BUST4)	1

**TECHNICAL SPECIFICATIONS**

	Power supply	Consumption	Insulation	Protection rating (IP)	Working temp. (°C Min. Max)	Dimensions (mm)
INB	to BusT4, or 24 Vac/dc (limits 20 ÷ 35 Vdc, 22 ÷ 35 Vac)	approx. 18 mA	class III	20	-20÷50 °C	41x52x18h

# O-BOX

OPERA

**O-Box is the multi-function interface** which, thanks to the dedicated software "**O-Box Software Suite**", enables **the configuration and programming directly from the PC or PDA**, practically and intuitively, **all transmitters, receivers and other Nice control devices.**

### The convenience of remote control:

O-Box enables a number of tasks to be performed directly from the office, **without the need to visit the client's system.** For example the operator can program the functions and parameters of transmitters with the utmost of ease, and send them already configured and operative to the clients.



### Many functions!

It is also possible to:

- program transmitters in the One series via radio;
- manage all functions via radio of the receivers in the One series fitted with built-in transmitter;
- read and write transponder badges in the Moon series;
- receive data via radio from transmitters in the series Smilo, VeryVE, Flo, VeryVR, FloR, One, Niceway or via optical reader for transmitters in the Bio series;
- program receivers in the series Smilo, Bio, FloR and One and memories of the control devices MOMB, MOTB and MORX;
- create and manage an updated database with personal data of clients and configurations of the receivers installed in the respective systems.

O-Box interfaces with your PC or PDA palmtop, performing the control, entry, deletion, enabling or disabling of codes, programming of the memory, functions and typical parameters of the receivers, transmitters and other Nice control devices.

### The software "O-Box Software Suite"

can be installed quickly and easily either on PC (O-Box Desktop version) or on PDA palmtop (O-Box Mobile version).

**Universal:** O-Box manages all programming procedures possible by means of BUPC.

It also enables import of databases previously created using the software for BUPC.

CODE	DESCRIPTION	PC./PACK
<b>OBOX2</b>	MULTIPURPOSE INTERFACE COMPLETE WITH SOFTWARE "O-BOX SOFTWARE SUITE" WITH USB CONNECTION CABLE SUPPLIED. DUAL BAND, FOR DEVICES AT 433.92/868.46 MHz	1
<b>OBOX2B</b>	MULTIPURPOSE INTERFACE COMPLETE WITH SOFTWARE "O-BOX SOFTWARE SUITE" WITH USB CONNECTION CABLE AND INTEGRATED BLUETOOTH MODULE. DUAL BAND, FOR DEVICES AT 433.92/868.46 MHz	1

### TECHNICAL SPECIFICATIONS

CODE	OBOX2	OBOX2B
FREQUENCY RECEPTION (MHz)	433.92/868.46	
ESTIMATED RANGE (m)	10	
COMMUNICATION WITH WINDOWS	USB, RS232	BLUETOOTH, USB, RS232
COMMUNICATION WITH WINDOWS MOBILE	BLUETOOTH	
WORKING TEMP. (°C MIN/MAX)	-20 : +55	
DIMENSIONS (mm)	195x116x48	
WEIGHT (g)	412	418

### ACCESSORIES

CODE	DESCRIPTION	PC./PACK
<b>ALA1</b>	BATTERY CHARGER POWER SUPPLY UNIT	1
<b>CABLA01</b>	CABLE FOR CONNECTING O-BOX TO THE COMPUTER VIA THE RS232 PORT	1
<b>CABLA02</b>	OPTICAL READER FOR PROGRAMMING TRANSMITTERS IN THE SERIES "BIO" AND "FLOR"	1
<b>CABLA03</b>	CABLE FOR CLONING TRANSMITTERS IN THE SERIES "VERY"	1
<b>CABLA04</b>	CABLE FOR CLONING TRANSMITTERS IN THE SERIES "BIO" AND "FLOR"	1
<b>CABLA05</b>	CABLE FOR PROGRAMMING TUBULAR MOTORS FOR AWNINGS AND SHUTTERS, EQUIPPED WITH PORT TTBUS	1
<b>CABLA06</b>	CABLE FOR PROGRAMMING RECEIVERS UNIVERSAL IN THE SERIES "SMX" AND "OX"	1
<b>CABLA07</b>	CABLE FOR CLONING TRANSMITTERS IN THE SERIES "ERGO" AND "PLANO"	1
<b>CABLA09</b>	CABLE FOR CLONING TRANSMITTERS IN THE SERIES "ERA-FLOR"	1

### NOTE ON CABLA ACCESSORIES:

O-Box is only supplied with the USB cable; all other cables are optional and are not supplied in the pack.

### Minimum software installation requirements

#### O-Box Mobile version for PDA palmtop:

- Processor: (300 MHz) Recommended by Nice: (> 300 MHz)
- RAM: 64 MB Recommended by Nice: 128 MB
- Storage memory: 5 MB Recommended by Nice: 20 MB
- Operating system: Windows® Mobile 2003 Recommended by Nice: Windows® 5.0
- Connection: Bluetooth®
- Graphics resolution: 240 x 320, 256 colours
- PC with: CD-Rom (required for software installation on palmtop).

#### O-Box Desktop version for PC:

- Processor: type AMD®/Intel® (500 MHz) Recommended by Nice: type AMD®/Intel® (1 GHz)
- RAM: 128 MB Recommended by Nice: 256 MB
- Free space on disk: 280 MB Recommended by Nice: 512 MB
- Operating system: Windows® 98 SE or later Recommended by Nice: Windows® 2000 or later up to Win 9
- Connection: Bluetooth®
- Graphics resolution: 800 x 600, 256 colours
- Disk drive: CD-Rom (required for installation).

Note - software installation includes installation of the program Microsoft®.NET Framework Redistributable 2.0.

# OX4T

OPERA

## Universal 4-channel receiver in the One series, with built-in transmitter.

For remote control of any automation on gates, garage doors, road barriers, shutters, awnings, venetian blinds, irrigation and lighting systems or other electrical circuits.

## Equipped with BUS T4 connector for connection to O-View.

### An extended system:

OX4T manages 4 outputs controlled by 4 relays, usable as power relays or voltage-free contacts, to extend use of the Opera system also to devices with specific provisions.

Thanks to the internal transmitter, OX4T can be used as a repeater, thereby increasing the operating range between transmitters and other receivers in the One series.



### Practical and functional:

OX4T can be connected via radio to the interface O-Box and via BUS T4 to the multifunction display O-View, to enable programming, diagnostics, timed functions and management of codes, also remotely by means of the modules OVBT and OVBTGSM.

### 2 programming modes:

"Mode I" and the new "extended Mode II" which enables expansion of the number of controls to up to 14.

**Multicode:** OX4T is also compatible with the transmitters with encoding system O-code, Smilo, Flo, FloR, FloR and TTS.

OX4T is fitted with removable terminals to facilitate connections and a generously sized memory to enable storage of up to 1024 transmitters, with the option for password protection.

CODE	DESCRIPTION	PC./PACK
OX4T	UNIVERSAL 4-CHANNEL RECEIVER WITH BUILT-IN TRANSMITTER	1

### TECHNICAL SPECIFICATIONS

POWER SUPPLY (Vac 50/60 Hz)	: 110 ± 240
MAXIMUM ABSORBED CURRENT (mA)	: 80
ENCODING	: O-CODE / TTS / FLOR (ROLLING CODE); OR SMILO (ROLLING CODE) OR FLO
FREQUENCY (MHz)	: 433.92
ANTENNA IMPEDANCE (Ohm)	: MORE THAN 0.5 FOR SUCCESSFUL SIGNAL
ESTIMATED RANGE (m)	: 200 IN OPEN SPACES 35 IF INSIDE BUILDINGS
RADIATED POWER (Dbm)	: +2
MAX. CAPACITY OF TRANSMITTER MEMORY	: 1024 (MAXIMUM)
OUTPUTS	: 4 RELAYS WITH NO AND NC CONTACTS, VOLTAGE-FREE
CONTACT CAPACITY	: 5 A - 250 V
TIMER TIMES	: PROGRAMMABLE FROM 2 SECONDS TO 540 MINUTES
PROTECTION RATING (IP)	: 44 (WITH CONTAINER INTACT)
WORKING TEMP. (°C MIN/MAX)	: FROM -20° TO +55°
DIMENSIONS (mm)	: 128X112X43 H
WEIGHT (g)	: 260

### ACCESSORIES

CODE	DESCRIPTION	PC./PACK
OVA1	CLAMP FOR FITTING CONNECTORS RJ14	1
OVA2	CONNECTORS RJ14, TYPE 6/4, FOR FLAT 4-WIRE CABLE	10
OVA3	RJ14 SPLITTERS, TYPE 6/4, FOR CASCADE CONNECTION OF DEVICES ON BUS T4 NETWORK	5
OVA4	FLAT 4-WIRE CABLE FOR CONNECTION OF DEVICES ON BUS T4 NETWORK, LENGTH 100 m	1



OVA1

OVA2

OVA3

OVA4

# TAG SYSTEM

## Ideal for restorations and upgrades of existing systems.

The Tag system, disappearing inside standard wall mounted plates and suitable to confined spaces, are ideal for restorations and upgrades of existing systems to control home automations, lighting points and all loads up to 500 W not directly accessible from cable controls.

All without the need to replace the existing system or involve building work!

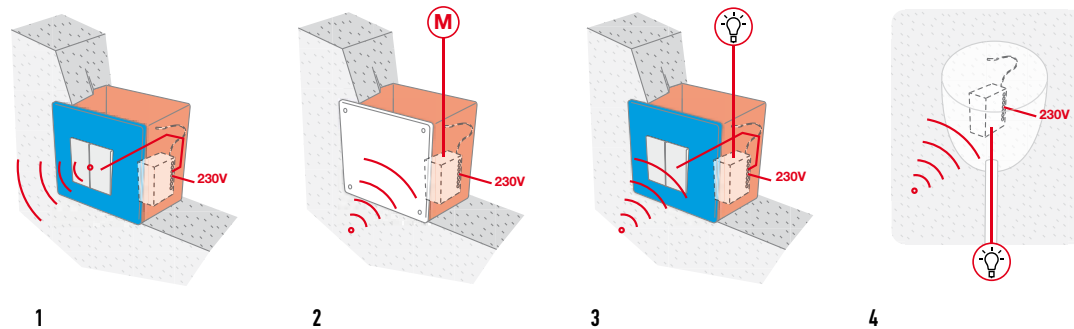
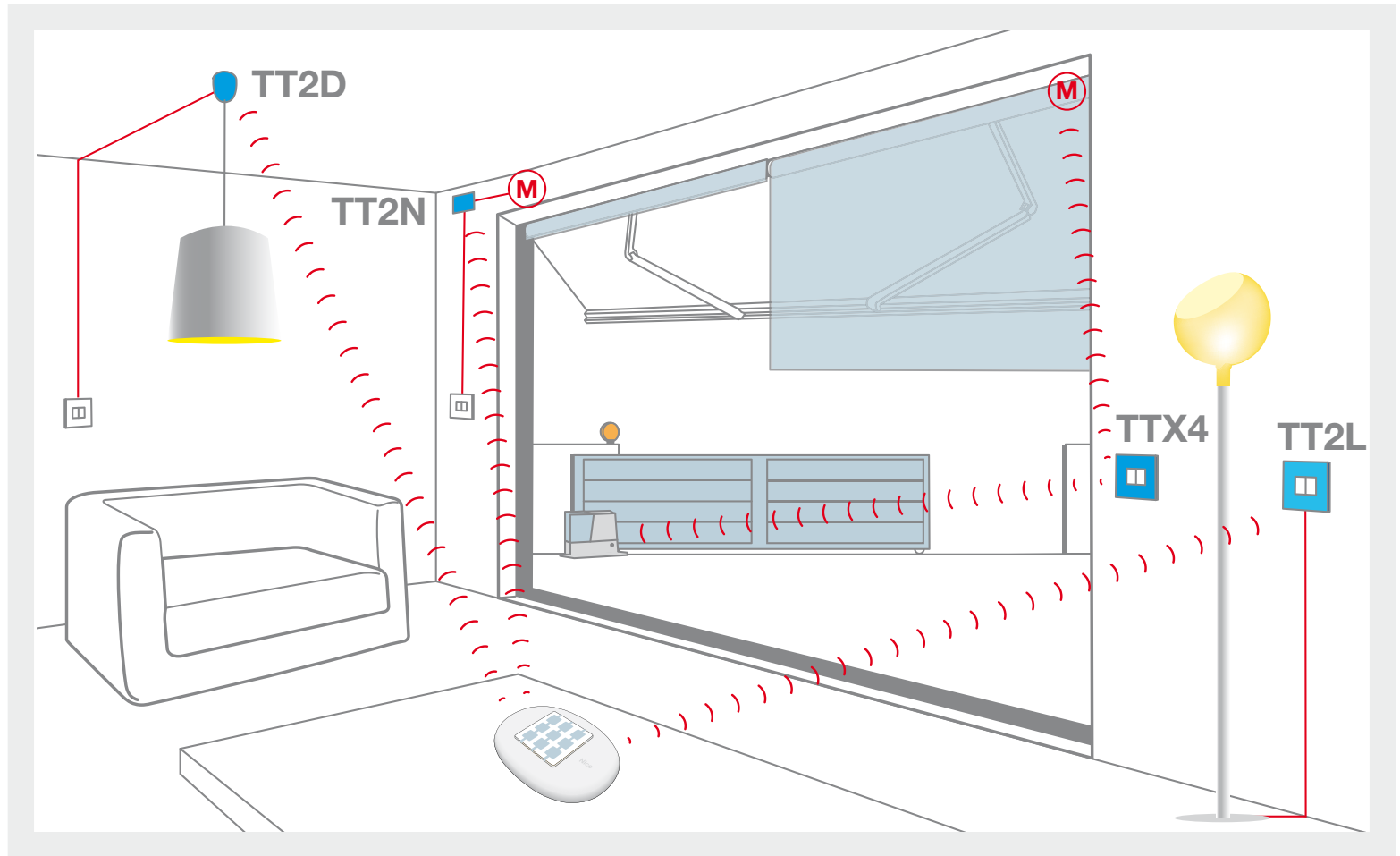

1. **TTX4: recessed transmitter** with mains power supply. Ideal for the control of automations not directly accessible from cable controls.
2. **TT2N: miniaturised control unit** for control of a 230 Vac motor up to 500 W, with built-in radio receiver.
3. **TT2L: miniaturised control unit** for control of lighting systems, with built-in radio receiver.
4. **TT2D: miniaturised control unit** for control of lighting systems from multiple points, with built-in radio receiver and switch.



### Invisible, but highly effective

Since miniaturised control units are incorporated invisibly into ordinary wall plates, they allow quick and easy installation and unbeatable safe, precise connection with all system components. Extremely compact size.



### Perfect for every home

Ideal in renovation projects and when upgrading existing systems to control home automations, all with no need to replace the existing system or do any building works! What could be more discreet? It's Nice!



### Comfort and simplicity always

Tag system coupled to the transmitter range. With just a simple touch, NiceWay module allows the wireless control of awnings and shutters, automation, irrigation and lighting systems and all loads up to 1,000W/500 VA not accessible by cable and, what's more, offers the option of wire connecting the miniaturized control unit to the existing wall switch in order to get an additional control point.

# TTX4

**TTX4, recessed transmitter with mains power supply.** Ideal for the control of automations not directly accessible from cable controls.

433.92 MHz frequency, with 52 bit rolling code (over 4.5 million of billion combinations).

Mains power supply and with optional connection of up to 4 pushbuttons for control via cable of automations.

CODE	DESCRIPTION	PC/PACK
<b>TTX4</b>	RECESSED TRANSMITTER, 4 CHANNELS, WITH MAINS POWER	1

### TECHNICAL SPECIFICATIONS

CARRIER FREQUENCY	: 433.92 MHz ± 100 KHz
ESTIMATED RANGE	: 35 m INDOORS
CODING	: 52 BIT DIGITAL (4.5 MILLION BILLION COMBINATIONS)
POWER SUPPLY	: 120 OR 230 Vac, 50/60 Hz; (LIMITS 100 ÷ 255 V)
PROTECTION RATING (IP)	: 20
WORKING TEMP. (°C MIN/MAX)	: -20° ÷ +55°
DIMENSIONS (mm)	: 18x33x40 h



# TT2

**Mindy TT miniaturised control units**, totally compatible with the Nice transmitters in the series NiceWay, Flo, Very, Planotime, FloR and Smilo.

**Maximum flexibility:** can memorise up to 30 transmitters in Mode I and Mode II.

**Fast programming** thanks to the programming button. An indicator LED helps the user to follow the correct programming procedure, for example signalling when the set thresholds of the climatic sensor are exceeded.

**Possibility of connection** to climatic sensors Nemo and Volo S-Radio.

**IP20 protection level.**

**TT2N, control unit for 230 Vac motor up to 500 W, with built-in radio receiver.**

Possibility of connecting a pushbutton for cable control in mode STEP-BY-STEP - ALWAYS UP - ALWAYS DOWN.

Possibility of memorizing radio controls in Mode I: UP - STOP - DOWN - "HOLD-TO-RUN" DOWN  
Mode II: STEP-BY-STEP - UP STOP - DOWN STOP - STOP - "HOLD-TO-RUN" DOWN - "HOLD-TO-RUN" UP.

**TT2L, control unit for lighting systems, with built-in radio receiver.**

For the control of 230 Vac mains voltage loads with power up to 1000 W / 500 VA.

Simplified connections thanks to the switch connected directly to the power mains (not for TT2D).

Possibility of connecting a switch for cable control in ON/OFF mode.

Possibility of memorizing radio controls in Mode I: ON - OFF  
Mode II: ON/OFF - HOLD TO RUN - TIMER1 - TIMER2.

Connection to climatic sensor Volo S-Radio enables management of light activation and shutdown by means of the "Sun" sensor.

Programmable timer from a minimum of 0.5" to a maximum of approx. 9 hours; optimised programming procedure, maintaining set values also in the event of a power failure.

**TT2D, control unit for lighting systems from multiple points, with built-in radio receiver and switch.**

Same characteristics as TT2L.



TT2N

CODE	DESCRIPTION	PC/PACK
TT2N	CONTROL UNIT FOR 230 Vac MOTOR WITH BUILT-IN RADIO RECEIVER	1
TT2L	CONTROL UNIT FOR MANAGEMENT OF 230 Vac LIGHTING SYSTEMS, WITH BUILT-IN RADIO RECEIVER	1
TT2D	CONTROL UNIT FOR MANAGEMENT OF 230 Vac LIGHTING SYSTEMS, WITH BUILT-IN RADIO RECEIVER AND SWITCHING MODULE	1

## TECHNICAL SPECIFICATIONS

CODE	TT2N	TT2D	TT2L
POWER SUPPLY (Vac/Hz)	120 0 230 Vac, 50/60 Hz, LIMITS: 100÷255 Vac		
FREQUENCY (MHz)	433.92		
FOR TRANSMITTERS IN THE SERIES	NICEWAY, FLOR-S, FLO, VERYVE, VERYVR, SMILO		
MAXIMUM MOTOR POWER	500VA FOR VN = 230V, 600VA FOR VN = 120V	1000W/500VA FOR VN = 230V, 600W/600VA FOR VN = 120V	
PROTECTION RATING (IP)	20		
MANOEUVRE DURATION (SEC)	4÷240 S (FACTORY SETTING APPROX. 150 S)	1 S÷9 H (FACTORY SETTING TIMER1=1 MIN, TIMER2=10 MIN)	
WORKING TEMP. (°C MIN/MAX)	-20 ÷ +55		
DIMENSIONS (mm)	40x18x32		
WEIGHT (g)	20		



TT2L



TT2D

# TT1

## Mindy TT1 miniaturised control units with pass-through installation, IP55 protection,

With radio-controls 433.92 MHz receiver with over 4.5 million billion combinations.

Self-recognition of the transmitters of the NiceWay, Flo, Very, Planotime, FloR and Smilo series.

### TT1N for awnings and rolling-shutters.

For motors max. 500 W.

Total flexibility of motor control with 2 transmitter memorisation modes

Mode I: UP - STOP - DOWN

Mode II: STEP-BY-STEP - ASCENT ONLY - DESCENT ONLY - STOP.

Memorizes up to 30 transmitters.

Internal terminal board for connection.

Manages the new climatic sensors Nemo and Volo S-Radio for synchronised controls.

The work time can be programmed from a minimum of 4" to a maximum of 4'.

### TT1L for lighting systems, irrigation pumps, etc...

For controlling loads with a mains voltage of 230 Vac and power max 500 W.

Memorizes up to 30 transmitters.

Internal terminal board for connection.

Manages up to 2 timers for automatic switch off.

Maximum control versatility with 2 transmitter memorisation modes

Mode I: ON - OFF with separate buttons

Mode II: ON - OFF - MAN PRESENT - TIMER.

Timer can be programmed from a minimum of 0.5" to a maximum of approximately 9'.

CODE	DESCRIPTION	PC/PACK
TT1N	CONTROL UNIT FOR PASS THROUGH INSTALLATIONS FOR ONE 230 Vac MOTOR UP TO 500 W, WITH BUILT-IN RADIO-CONTROLLED RECEIVER. 2 PROGRAMMING MODES AND PROGRAMMABLE WORKING TIME	1
TT1L	CONTROL UNIT FOR PASS THROUGH INSTALLATIONS FOR LIGHTING/IRRIGATION SYSTEMS, 230 Vac MAX. 500 W, WITH BUILT-IN RADIO RECEIVER. 2 PROGRAMMING MODES AND 2 TIMERS FOR AUTOMATIC SWITCH OFF	1

### TECHNICAL SPECIFICATIONS

CODE	TT1N	TT1L
POWER SUPPLY (Vac/Hz)	230/50	
FREQUENCY (MHz)	433.92	
FOR TRANSMITTERS IN THE SERIES	NICEWAY, FLOR-S, FLO, VERYVE, VERYVR, SMILO	
MAXIMUM MOTOR POWER	500 W / 400 VA	
PROTECTION RATING (IP)	55	
MANOEUVRE DURATION (SEC)	PROG. 4-250	TIMER1 TIMER2 FROM 0.5" A 540"
WORKING TEMP. (°C MIN/MAX)	-20 ÷ +55	
DIMENSIONS (mm)	98x26x20	
WEIGHT (g)	45	







# ACCESSORIES



WIRELESS ACCESSORY SYSTEM	170	NICE SOLEMYO AIR NET SYSTEM
PHOTOCELLS AND SAFETY DEVICES	174 176 177	EVEN SAFER AUTOMATION FT210 F210
SYSTEM OF PHOTOCELLS, KEY-OPERATED AND DIGITAL SELECTOR SWITCHES, TRANSPONDER READERS AND CONTROLLING ENTRIES	178 179 180 181 182 183 184 185	MOONBUS MOON MOONTOUCHBUS MOONTOUCH MYMOONBUS MYMOON MOONKEY MOON ACCESSORIES
FLASHING LIGHTS	186 187	MOONLIGHT WALLYGHT
SELECTOR	188	KIO
PROGRAMMING UNITS	162 189	O-BOX BUPC



# NICE SOLEMYO AIR NET SYSTEM

Automation safety devices becomes wireless control systems!  
 Photocells, sensitive edge and flashing lightings all acquire a new function:  
 power is supplied by means of an integral miniature solar panel.  
 The solar panel powers rechargeable batteries to ensure independent operation  
 of the automation system in any conditions.



**1. Era Light Solemyo**  
Flashing light



**2. Kit Solemyo**  
Solar power kit



**3. Era TCW Solemyo**  
Sensitive edge transmitter



**4. Era Photocell Solemyo**  
Photocell



**5. Era Post Solemyo**  
Solemyo Era Photocell Post



# SOLEMYO

SOLEMYO 24V

**Solemyo is the solar power system to automate gates, garage doors and road barriers, even those located far from the electrical mains.**

Solemyo is available both in kit version and single products.

**Installable anywhere** without the need for connections or excavations, even in the most remote locations or those difficult to access with the power mains.

**Increased savings and respect for the environment** thanks to solar energy, free and clean: an ecological and intelligent choice with short term benefits.

**Low consumption with no risk of blackouts:** the extended duration of the energy reserve, combined with the low consumption of the automations, guarantee operation also in prolonged overcast conditions.

## THE KIT CONTAINS:

**SYP:** PHOTOVOLTAIC PANEL FOR 24 V SUPPLY.  
**PSY24:** 24 V BATTERY BOX WITH CONTROL CIRCUIT AND CARRY HANDLES. IT STORES THE ELECTRICAL ENERGY PRODUCED BY THE SYP PANEL, WITH CONTINUOUS AND PERMANENT SUPPLY THROUGHOUT THE DAY.  
**CABLES AND CONNECTORS NECESSARY FOR THE CONNECTION.**



SYKCE

PSY24

SYP

**Less consumption, more autonomous operation!**  
 Perfect operation ensured even at night time or in prolonged overcast conditions, guaranteeing comfort and safety.

**Ease of use**  
 The SYA1 auxiliary power supply unit enables rapid battery charging via a 230 Vac power mains, as an alternative to the photovoltaic module. Battery charge status LED indicators.

**Installation advice**  
 If two or more parallel-connected solar panels have to be installed, purchase individually the items that make up the Solemyo system to increase the system's charging capacity or use just one SYA1 transformer to charge several PSY24 battery boxes.

CODE	DESCRIPTION	PACK/PALLET
<b>SYKCE</b>	SOLAR POWER KIT COMPRISING SYP PHOTOVOLTAIC PANEL AND PSY24 BATTERY BOX WITH CHARGING CONTROL CIRCUIT	21
<b>SYP</b>	PHOTOVOLTAIC PANEL FOR 24 V SUPPLY WITH MAXIMUM POWER 15 W	
<b>SYP30</b>	PHOTOVOLTAIC PANEL FOR 24 V SUPPLY WITH MAXIMUM POWER 30 W	
<b>PSY24</b>	24 V BATTERY BOX WITH CONTROL CIRCUIT AND CARRY HANDLES	

**N.B.** The content of the package may vary: consult the retailer.

## TECHNICAL SPECIFICATIONS

CODE	PSY24	SYP30	SYP	SYA1
POWER SUPPLY (Vac 50/60 Hz)		-		110 ÷ 240
RATED VOLTAGE (V)		24		-
MAXIMUM CURRENT (A)	10		-	
PEAK POWER (Wp)	-	30	15	-
MAXIMUM POWER (W)		-		60
RATED BATTERY CAPACITY (Ah)	20		-	
PROTECTION LEVEL (IP)	44		-	
WORKING TEMP. (°C MIN/MAX)	-20 ÷ +50*		-40 ÷ +85	0 ÷ +40
COMPLETE RECHARGING TIME (HOURS)	~ 15**		-	
DIMENSIONS (mm)	235x170x258 h	450x25x550 h	390x28x415 h	132x58x30 h
WEIGHT (kg)	14	3.5	1.9	0.345

\* 0 ÷ 40 if recharged from the power mains with SYA1 power supply unit.  
 \*\* Using the power supply unit via the mains.

## ACCESSORIES



**SYA1**  
 POWER SUPPLY UNIT FOR CHARGING THE BATTERY PSY24 FROM THE SUPPLY MAINS.

PC/PACK 1



**The SYP30 photovoltaic panel,** sold individually, is ideal in all the situations with low exposure to the sun or automations with high intensity of use.

## INSTALLATION DIAGRAM



FLEXIBLE: SOLEMYO ADAPTS PERFECTLY TO ALL TYPES OF INSTALLATION.

# NICE SOLEMYO AIR NET SYSTEM

NEW

## So many benefits!

**Quick installation:** no need to lay wiring to connect the accessories to the control unit, drilling holes or laying raceways: just position them as appropriate and let the control unit identify them.

Devices interface with the control unit by means of a special, very compact interface module that can be fitted directly inside the motor, or the control unit, if separate.

## Better appearance, flexible positioning of devices over time:

it is very easy to add (or remove) devices, with no need to search for a mains connection point or a contact for series connection.

## Extremely reliable transmission:

**the radio system allows two-way communication -**

each device does not just respond to the control unit's instructions but sends a feedback signal, confirming that it is present and operational, and it also signals the occurrence of events such as the passage of an object between the two photocells.

**Operating Frequency: 868 MHz**, less liable to interference.

Two separate channels are used, for a 100% guarantee of the system's operation and safety even in case of sudden interference.

**Intelligent system:** it detects whether any interference is from another Nice wireless automation unit.

In this case, the "new" automation system just installed selects two communication channels different from those used by the existing system, keeping the two systems' channels separate.

Each device has LEDs in the bottom indicating the signal quality and troublefree operation of the system, which can be checked immediately in the event of malfunction or at first start-up.

A LED flashes when the device is receiving enough solar power to allow recharging.

## Solemyo Era Photocell

**Pair of PHW two-way wireless photocells**, with photovoltaic cell power supply.

**Easy installation:** the receiver photocell has a special LED that indicates the degree of alignment with the transmitter photocell, very useful during initial installation.

## Solemyo Era Light

**Wireless LLW flashing light**, with extremely high-efficiency LEDs lower consumption and virtually unlimited lifetime (no more blown lamps needing frequent changing).

Light output adapts to ambient conditions to ensure good visibility even in direct sunlight and to save energy during the hours of darkness.

Can be used as flashing signal or courtesy light.

## COMPATIBILITY/INTERFACE TABLE

	PHW	LLW	TCW1	TCW2
<b>Control units with BLUEBUS system (*)</b>	With IBW	With IBW	With IBW (**)	With IBW (**)
<b>Control units without BLUEBUS system</b>	Not possible	Not possible	With IRW	With IRW

(\*) There may be any limitations on the number of devices managed.

(\*\*) Not managed in automation for swing gates (MC824H; Walky; Hopp; Hyke) and in some automations for garage doors (SN6020\*; SN6021\*; SPIN2\*; SPIN20\*; SPIN21\*; SPOK).

CODE	DESCRIPTION	PC/PACK
<b>PHW</b>	PAIR OF WIRELESS PHOTOCELLS WITH BUILT-IN PHOTOVOLTAIC PANEL	1
<b>PPH1</b>	PHW PHOTOCELL POST, h. 50 cm	1
<b>PHWA1</b>	PAIR OF ADAPTERS FOR PHW ON PPH1 POSTS	1
<b>LLW</b>	WIRELESS FLASHING LIGHT WITH BUILT-IN PHOTOVOLTAIC PANEL	1
<b>IBW</b>	INTERFACE BETWEEN PHW/LLW AND CONTROL UNITS WITH BLUEBUS SYSTEM	1



LLW



PHW



PPH1

# ERA TCW

NICE&SAFE

NEW

**Even safer automation thanks to the Nice Solemyo Air Net System's new sensitive edge sensors.**

**No connection, totally wireless, powered by the sun.**

### Energy saving

thanks to the solar power cell built into the TCW2, with rechargeable batteries.

Version with battery-only operation is also available in case of installations with low exposure to sunlight.

**Unbeatable safety** thanks to the "wireless" system for detection and communication between sensitive edge, interface and control unit, allowing swift action when an obstacle is detected.

### Quick and easy to install:

maximum flexibility in installing the devices.  
Possibility of connection to 8.2 KOhm resistive sensitive edges.

**State-of-the-art technology: IBW interfaces,** for Nice BlueBus-compatible control units, and **IRW,** interfaces, for control units without BlueBus connection, allow radio communication with **TCW** sensors.

### Suitable for any architectural context

Compact size: 99x49x33.



TCW2



TCW1

CODE	DESCRIPTION	PC/PACK
<b>TCW1</b>	BATTERY -POWERED WIRELESS TRANSMITTER FOR SENSITIVE EDGES. SUITABLE FOR INTERNAL USE OR SPARSELY SUNNY AREAS	1
<b>TCW2</b>	PHOTOVOLTAIC PANEL AND RECHARGEABLE BATTERY-POWERED WIRELESS TRANSMITTER FOR SENSITIVE EDGES. SUITABLE FOR EXTERNAL USE OR SUNNY AREAS	1
<b>IBW</b>	BLUEBUS WIRELESS INTERFACE FOR SENSITIVE EDGES WITH WIRELESS TRANSMITTER FOR BLUEBUS SYSTEM CONTROL UNITS	1
<b>IRW</b>	RELAY WIRELESS INTERFACE FOR SENSITIVE EDGES WITH WIRELESS TRANSMITTER FOR CONTROL UNITS WITH CLASSICAL CONNECTIONS (STOP AND PHOTO)	1

### TECHNICAL SPECIFICATIONS

CODICE	TCW2	TCW1
TECHNOLOGY USED	RADIO DATA RECEPTION AND TRANSMISSION, WITH CHOICE OF 2 FREQUENCIES IN THE 868 MHz BAND	
POWER SUPPLY	PHOTOVOLTAIC CELL WITH ELECTRICITY STORED IN A RECHARGEABLE AAA NIMH BATTERY	2 ALKALINE BATTERIES
BATTERY LIFE	ESTIMATED 4-5 YEARS *	ESTIMATED 2-3 YEARS, WITH 1200 MAH ALKALINE BATTERIES
MAXIMUM NUMBER OF OPERATIONS PER DAY	15 OPERATIONS LASTING NO MORE THAN 1 MINUTE (1 CYCLE = OPENING + CLOSING)	
SENSITIVE EDGE (RS) INPUT RANGE	TYPICALLY 8,2 KOhm	
RADIO OPERATING RANGE (MAX)	20M (40M)	
FAILSAFE CATEGORY	2 (UNDER EN 945-1 STANDARD) DEPENDING ON "FOTOTEST" INPUT AND OUTPUT CONNECTION TYPE	
HOUSING PROTECTION RATING	IP44	
OPERATING TEMPERATURE	-20 ÷ +55°C	
DIMENSIONS (mm)	99x49x33	
WEIGHT (g)	130	145

\* The stated estimates refer to edges functioning for about 15 operations per day, with complete cycle time of 60 seconds (900 seconds per day).

### INSTALLATION DIAGRAM

\*IBW or IRW depending on the motor (only IBW accepts also PHW and LLW)

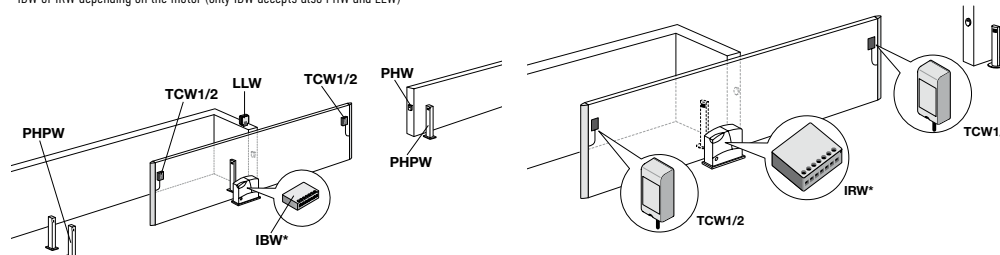

#### TCW + IBW

The IBW is connected to the control unit's BlueBUS terminal and communicates with the TCW by radio. Compatible also with PHW wireless photocell and LLW wireless flashing light.

#### TCW + IRW

IRW is connected to safety input (Stop and Photo) of control unit and communicates via radio with TCW.

## 8.2 KOhm resistive sensitive edges, maximum safety and control of the automation.

**Safer:** if there are any faults in the system like, for example, the product itself has broken down, the edges will communicate this to the control unit. The TCE interface board enables users to connect sensitive edges (with 8.2 KOhm resistance) to those control units which are not equipped with a special input.

### The length can be personalised:

the components supplied in the kits enable installers to build sensitive edges of the correct dimension.

**Practical:** they adapt to any kind of situation and can be installed quickly.

**Reliable:** the new Class3 technology means that the control unit, the sensitive edges are connected to, can understand if the device is functioning correctly, or if it is out of use.

### 8.2 KOhm analogical-type input.



TCB65



TCK



TCF



TCA65

### Resistive sensitive edges and accessories

CODE	DESCRIPTION	PACK
<b>TCB65</b>	SENSITIVE EDGE IN 10 m ROLLS	1
<b>TCK</b>	KIT PUTTING TOGETHER 8 SENSITIVE EDGES COMPLETE WITH: - TERMINAL CAPS (TCT65) - CONNECTORS, COMPLETE WITH CABLE L=250 CM (TCS250) - CONNECTORS 8.2 KOHM (TCER) - TIN OF GLUE (TCC) - TIN OF PRIMER (TCP)	16 8 8 1 1
<b>TCF</b>	SCISSORS FOR CUTTING SAFETY SENSITIVE EDGES	1
<b>TCA65</b>	ALUMINIUM PROFILE L=200 CM	5
<b>TCE</b>	CONTROL INTERFACE FOR SENSITIVE EDGE	1

### Electrical connection devices for safety sensitive edges on moveable leaves

CODE	DESCRIPTION	PACK
<b>DBM5</b>	COMPLETE KIT FOR GATES UP TO 5 m	1
<b>DBM7,5</b>	COMPLETE KIT FOR GATES UP TO 7.5 m	1
<b>DBM10</b>	COMPLETE KIT FOR GATES UP TO 10 m	1

### Instruments and software for force impact measurement

CODE	DESCRIPTION
<b>NSFB</b>	BLUEFORCE INSTRUMENT FOR MEASURING THE IMPACT FORCE COMPLIANT WITH EN12445, WITH BLUETOOTH/USB INTERFACE AND SOFTWARE INCLUDED, COMPLETE WITH CARRY CASE
<b>NSFS</b>	SPEEDFORCE INSTRUMENT FOR MEASURING THE IMPACT FORCE COMPLIANT WITH EN12445, WITH USB INTERFACE AND SOFTWARE INCLUDED COMPLETE WITH CARRY CASE
<b>NSEL</b>	STRAIGHT EXTENSION FOR MEASUREMENTS FROM 30 TO 50 CM, APPLICABLE ON NSFB AND NSFS
<b>NSEA</b>	ANGULAR EXTENSION FOR MEASUREMENTS FROM 1.25 TO 2.50 m, APPLICABLE ON NSEL
<b>NSSWPDA</b>	BLUEFORCE PDA SOFTWARE FOR POCKET-PC, FOR NSFB



TCE



DBM5, DBM7,5, DBM10



NSFB, NSFS

## Mechanical sensitive edges, more safety and easy installation.

**CMA** is the pre-assembled, high mechanical edge consisting in aluminium profiles of 1.5 - 1.7 - 2 - 2.5 m in length; ideal for assembly on sliding or swing gates.

**CMBK** is the kit for installing a low mechanical edge: for edges max. 4 m (CMBK4) and for edges max. 6 m (CMBK6), ideal for garage doors in general, up-and-over and sectional doors.

**CB** is a protective rubber pad. Fitted to the CMBK4/CMBK6 kit, it forms the low mechanical edge.

### Mechanical sensitive edges

CODE	DESCRIPTION	PACK
	HIGH MECHANICAL EDGE WITH ALUMINIUM PROFILES IN SECTIONS MEASURING 1.5 - 1.7 - 2 - 2.5 m IN mm 36x75 h:	
<b>CMA 1,5MT</b>	LENGTH 1.5 m	1
<b>CMA 1,7MT</b>	LENGTH 1.7 m	1
<b>CMA 2MT</b>	LENGTH 2 m	1
<b>CMA 2,5MT</b>	LENGTH 2.5 m	1
<b>CB</b>	PROTECTIVE RUBBER PAD FOR LOW ROLLED MECHANICAL EDGE AND ALUMINIUM PROFILES IN SECTIONS MEASURING 2 m; DIMENSIONS IN mm 23x44 h	40
<b>CMBK4</b>	KIT FOR INSTALLING A LOW MECHANICAL EDGE, WITH ALUMINIUM PROFILES MEASURING 4 m (TO USE TOGETHER WITH CB)	1
<b>CMBK6</b>	KIT FOR INSTALLING A LOW MECHANICAL EDGE, WITH ALUMINIUM PROFILES MEASURING 6 m (TO USE TOGETHER WITH CB)	1

### Passive sensitive edges

CODE	DESCRIPTION	PACK
<b>TCBS60</b>	PASSIVE SENSITIVE EDGE IN 10 m ROLLS	1



CMA



CB



TCBS60

## Inductive magnetic detector loop.

Magnetic sensor for the detection of metal objects.

**Simple and safe:** operation and parameters are easily controlled, checked and programmable via the LCD display.

**Quick and versatile:** unlimited functions and simple, intuitive programming.

### Integrated measurement system

Automatic indication of loop inductance.

CODE	DESCRIPTION	PACK
<b>LP1</b>	SINGLE-CHANNEL METAL MASS DETECTOR 24 V POWER SUPPLY	1
<b>LP2</b>	TWO-CHANNEL METAL MASS DETECTOR 24 V POWER SUPPLY	1



LP1, LP2

# FT210

NICE&SAFE

BLUEBUS

**Optical device, with wireless transmitter to secure on moveable leaf, horizontally adjustable through 210° and 30° vertically, for an automation according to Standards.**

### Consideration towards personal safety and product quality.

The safety level of the main edge, required by the EN12453 standard, can be achieved for any "type of use" and any "type of activation" by integrating a FT210/FT210B device to an 8.2 KOhm TCB65 type resistive sensitive edge.

The FT210/FT210B device, integrated with a "resistive" sensitive edge (8.2 KOhm), is safe against individual faults (category 3 according to the EN 954-1 standard) or can be used with automated systems with self-diagnosis at the start of every manoeuvre (category 2 according to the EN 954-1 standard).

### Additional models

Versions with relay output (FT210), with Nice BlueBUS technology (FT210B), available with 2 Ah (FTA2) and 7Ah (FTA1) battery Kit, for intensive use.

### Cutting-edge technology

The anti-collision circuit avoids interference with other out-of-sink receivers.

The FT210/FT210B optical devices are equipped with a special sensor capable of recognizing when the gate is motionless, which remains in a low consumption mode and activates only when the gate is in motion. Range adjustable on 2 levels; alignment with proportional LED for easy and safe installation.

### Suitable for any architectural environment and easy to install

Reduced dimensions: 46x128x45; electrical connections can also be made from the lower section of the box.

### Resilient and safe

Polycarbonate casing; FA1 vandal-proof metal shell (optional); low transmitter battery indicator.



MOCF2

MOCF



FA1, FA2

CODE	DESCRIPTION	PC/PACK
FT210	PAIR OF OPTICAL DEVICES FOR SENSITIVE EDGES FASTENED ON MOVING DOOR, CAN BE SWIVELLED THROUGH 210° WITH RELAY OUTPUT. BATTERY KIT (FTA1/FTA2) COMPULSORY	1
FT210B	PAIR OF OPTICAL DEVICES FOR SENSITIVE EDGES FASTENED ON MOVING DOOR, CAN BE SWIVELLED THROUGH 210° WITH BLUEBUS TECHNOLOGY. BATTERY KIT (FTA1/FTA2) COMPULSORY	1

### TECHNICAL SPECIFICATIONS

	Estimated range (m)	Power supply	Absorption	Protection rating (IP)	Working temp. (°C Min/Max)	Range relè	Dimensions (mm)	Weight (g)
FT210	10 (residential), 15 (industrial)	RX: 12-24 Vac/Vdc limits: 18-35 Vdc, 10-28 Vac TX: 3.6 V lithium battery	RX: 120 mA - 12 V, 70 mA - 24 V TX: 20 uA gate not moving, 450 uA gate operating	44	-20 ÷ +55	max 500 mA and 48 V	46x45x128 h	300
FT210B		RX: the device can only be connected to "BlueBUS" networks	1 BlueBUS unit TX: 20 uA gate not moving, 450 uA gate operating					280

### ACCESSORIES

CODE	DESCRIPTION	PC/PACK
FA1	VANDAL-PROOF METAL SHELL	2
FA2	BRACKET FOR FIXING TO MOCF AND MOCF2 COLUMNS	5
FTA1	7 Ah BATTERY KIT FOR FT210/FT210B TRANSMITTERS, FOR INTENSIVE USE	1
FTA2	2 Ah BATTERY KIT FOR FT210/FT210B TRANSMITTERS	1
MOCF2	ALUMINIUM POST FOR 2 PHOTOCELLS, 1000 mm HIGH	2
MOCF	ALUMINIUM POST FOR 1 PHOTOCELL, 500 mm HIGH	2

### Gates

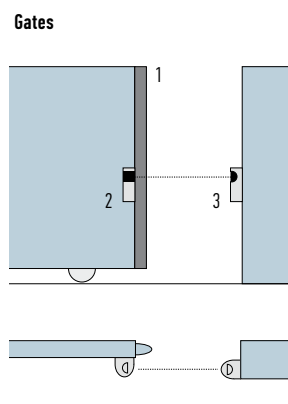

1. TCB65, RESISTIVE SENSITIVE EDGES
2. TX FT210 POWER SUPPLY WITH BATTERY
3. RX FT210.



# F210

BLUEBUS

**Synchronised photocells horizontally adjustable through 210° and 30° vertically. Simply perfect installations.**

### The 210° solution

The beam of the Nice F210 and F210B photocells has a horizontal scope of 210°, thereby increasing the safety level of the system and simplifying installation: the gate or garage door to be automated quite often slide flush with the wall making it very difficult to position the photocell.

### Numerous models and countless advantages

The new photocells are available with relay output (F210) or with the Nice BlueBUS technology (F210B).

With the BlueBUS technology, all devices can be easily connected to the control unit with just two wires.

Sensors with the BlueBUS technology can be connected to incompatible control units by means of an IB interface. The devices that are connected to the BlueBUS network are automatically acquired by the system.

### Suitable for any architectural environment and easy to install

Reduced dimensions: 46x128x45 mm; electrical connections can also be made from the lower section of the box.

### Resilient and safe

Polycarbonate casing; FA1 vandal-proof metal shell (optional).

### Cutting-edge technology

The problem of interference between the sensors and the automatic synchronisation between several pairs of photocells is solved by the anti-blinding circuit; high range adjustable on 2 levels; synchronising circuit; alignment with proportional LED for easy and safe installation.



F210, FA1



MOCF2

MOCF

CODE	DESCRIPTION	PC/PACK
F210	PAIR OF SYNCHRONISED PHOTOCELLS ADJUSTABLE THROUGH 210°, WITH RELAY OUTPUT	1
F210B	PAIR OF SYNCHRONISED PHOTOCELLS ADJUSTABLE THROUGH 210°, WITH THE NICE BLUEBUS TECHNOLOGY	1

### TECHNICAL SPECIFICATIONS

	Estimated range (m)	Power supply	Absorption	Protection rating (IP)	Working temp. (°C Min/Max)	Range relè	Dimensions (mm)	Weight (g)
F210	10 (30 with jumper cut)	without jumper 24 Vac/Vdc limits: 18-35 Vdc, 15-28 Vac with jumper 12 Vac/Vdc limits: 10-18 Vdc, 9-15 Vac	25 mA RX, 30 mA TX	44	-20 ÷ +55	max 500 mA and 48 V	46x45x128 h	230
F210B		the device can only be connected to "BlueBUS" networks	1 BlueBUS unit			-		

### ACCESSORIES

CODE	DESCRIPTION	PC/PACK
IB	INTERFACE FOR CONNECTING BLUEBUS F210B PHOTOCELLS UP TO CONTROL UNITS WHICH HAVE NOT BEEN MANUFACTURED FOR THIS PURPOSE	1
FA1	VANDAL-PROOF METAL SHELL	2
FA2	BRACKET FOR FIXING TO MOCF AND MOCF2 COLUMNS	5
MOCF2	ALUMINIUM POST FOR 2 PHOTOCELLS, 1000 mm HIGH	2
MOCF	ALUMINIUM POST FOR 1 PHOTOCELL, 500 mm HIGH	2

### TECHNICAL SPECIFICATIONS

	Power supply	Current draw with 24 Vdc power supply	Current draw with 24 Vdc power supply	BlueBUS output	Protection rating (IP)	Working temp. (°C Min/Max)	Dimensions (mm)	Weight (g)
IB	16÷35 Vdc 18÷28 Vac	50 mA (add approx. 50 mA for each pair of photocells)	44 mA (add approx. 44 mA for each pair of photocells)	one with maximum load of 9 BlueBUS units	30	-20 ÷ +55	86x58x22 h	72



IB



FA1, FA2

# MOONBUS

BLUEBUS

## Fixed or adjustable, synchronised photocells with BlueBUS technology.

The **MOFB** and **MOFOB** photocells are obstacle detectors which make it possible to detect obstacles on the optical axis between a transmitter (TX) and a receiver (RX), type D according to Standard EN12453.

They can be used in automations for gates and doors.

These devices are equipped with the **BlueBUS** communication system which makes it easy to connect all the devices up to the control units using two wires only.

They are all quite simply connected up in parallel, and the addressed jumpers selected according to the function required.

### Cutting-edge technology:

an anti-blinding circuit that makes it possible to solve the problem of interference between the detectors and automatic synchronisation between several couples of photocells.

The **MOFOB** version, which can be adjusted, will solve the problem of compensating centring gaps up to 30°.

**IB Interface:** enables the user to connect obstacle detectors using BlueBUS technology (MOFB and MOFOB photocells) and control units with inputs for traditional, photocell contacts. The system automatically recognizes the devices connected to the BlueBUS network. The phototest function enables users to achieve Safety Category 2 against faults according to Standard EN 954-1.



CODE	DESCRIPTION	PC/PACK
<b>MOFB</b>	SURFACE-MOUNTED PAIR OF PHOTOCELLS FOR CONNECTION BY NICE BLUEBUS	1
<b>MOFOB</b>	PAIR OF ADJUSTABLE 30°, SURFACE-MOUNTED PHOTOCELLS FOR CONNECTION BY NICE BLUEBUS	1
<b>IB</b>	INTERFACE FOR CONNECTING BLUEBUS MOFB AND MOFOB PHOTOCELLS UP TO CONTROL UNITS WHICH HAVE NOT BEEN MANUFACTURED FOR THIS PURPOSE	1

### TECHNICAL SPECIFICATIONS

	Power supply/output	Adjustability of the photocell	Estimated range (m)	Protection rating (IP)	Working temp. (°C Min/Max)	Dimensions (mm)	Weight (g)
<b>MOFB</b>	the device can only be connected to "BlueBUS" networks, from which it receives its power supply and sends output signals	-	up to 15 m for a maximum TX-RX misalignment of ± 5° (the device can detect and signal an obstacle even in particularly bad weather conditions)	55	-20 ÷ +55	69x25x78 h	50
<b>MOFOB</b>		approximately 30° along the horizontal and vertical axes				69x37x78 h	75

	Power supply	Current draw with 24 Vdc power supply	Current draw with 24 Vdc power supply	BlueBUS output	Protection rating (IP)	Working temp. (°C Min/Max)	Dimensions (mm)	Weight (g)
<b>IB</b>	16÷35 Vdc 18÷28 Vac	50 mA (add approx. 50 mA for each pair of photocells)	40 mA (add approx. 40 mA for each pair of photocells)	one with maximum load of 9 BlueBUS units	30	-20 ÷ +55	86x58x22 h	72



# MOON

**Synchronised photocells with a 10° receiving angle (MOF) also available in a 30° version adjustable in each direction (MOFO).**

**Ultra-thin:**  
just 28 mm (adjustable version: 38 mm).

**Extremely hard-wearing:**  
transparent polycarbonate casing.

2 range levels.

Synchronisation circuit.

Alignment with proportional LED for safe and easy installation.



CODE	DESCRIPTION	PC/PACK
<b>MOF</b>	PAIR OF SURFACE-MOUNTED PHOTOCELLS	1
<b>MOFO</b>	PAIR OF ADJUSTABLE 30°, SURFACE-MOUNTED PHOTOCELLS	1

## TECHNICAL SPECIFICATIONS

	Estimated range (m)	Power supply	Absorption (mA)	Protection rating (IP)	Working temp. (°C Min/Max)	Range relè	Dimensions (mm)	Weight (g)
<b>MOF</b>	15 (30 with jumper + "10 m" cut)	without jumper 24 Vac/Vdc limits 18-35 Vdc, 15-28 Vac	25 RX, 30 TX	54	-20 ÷ +55	max 500 mA and 48 V	69x25x78 h	55
<b>MOFO</b>		with jumper 12 Vac/Vdc limits 10-18 Vdc, 9-15 Vac					69x37x78 h	80



# MOONTOUCHBUS

BLUEBUS

## 12-key digital selector with Nice BlueBUS connection technology.

### Exclusive functions:

- 2 keys to activate two different commands selected from 6 available (for example step-step, close, open), depending on which control unit is connected;
- 255 combinations for storage on BM1000 memory;
- 2 programming modes: Easy or Professional;
- up to 4 MOTB and MOMB control devices connectable via BlueBUS, also in combined configurations;
- possibility of programming the number of times a specific combination can be used;
- possibility of enabling an automation block/unblock function.



**Simple installation:** easy and rapid connection with just 2 wires, no polarity, to complete the BlueBUS systems.

**Safe:** the combination is a number consisting in 1 to 9 figures, resulting in 99,999,999 possible combinations!

**Two different visual indicators** according to automation status:

- red: automation closed or in closing phase;
- green: during opening or when the "automation block" function is active.

**Easy programming:** with MOU palmtop or O-Box interface, extremely simple management of any type of programming of the BM1000 memory in the vicinity of the system, or remotely, directly from the installer's office.

MOU and O-Box interface with the PC, enabling efficient archiving of all installations.

CODE	DESCRIPTION	PC/PACK
MOTB	12-KEY DIGITAL SELECTOR, IN ALUMINIUM, WITH NICE BLUEBUS TECHNOLOGY	1

### TECHNICAL SPECIFICATIONS

	Power supply	Absorption	Protection rating (IP)	Dimensions (mm)
MOTB	via BlueBUS	1.5 BlueBUS unit	54	70x30x80 h

# MOONTOUCH

## 12-key digital switch with 2-wire connection to decoder or radio-controlled.

**MOTXR:** radio coding digital switches with 52 bit FLOR rolling code; compatible with FloR receivers, rolling code 4.5 million billion combinations, with self-learning function.

**MOTXS:** radio coding digital switches with 64 bit Smilo rolling code; compatible with Smilo transmitters, with 64 bit rolling-code, generates 18 billion million combinations, with self-learning function.

**Complete:** 2 transmission channels to control 2 automations.

**Convenient:** no wiring necessary; estimated range: 200 m outdoors and 35 m indoors.



**Safe:** the combination is a number consisting in 0 to 8 figures, resulting in 99,999,999 possible combinations!

**Cheap:** extra low consumption, the transmission will activate when the user presses the key, and switch itself off automatically. The ambient brightness sensor only activates keypad lighting when necessary.

**Sturdy:** vandal-proof die-cast aluminium casing, IP54.

**MOT:** digital switch with 2-wire connection to decoder

- 255 combinations can be entered out of a total of 999,999,999, expandable to 510;
- 2 channels;
- 2 programming modes: Easy or Professional;
- programmable output functions with pulse relay, bistable or timed relay, anti-theft feature;
- up to 4 switches can be connected by cable to the same receiver, with different active combinations.

**Easy programming:** with MOU palmtop or O-Box interface, extremely simple management of any type of programming of the BM1000 memory in the vicinity of the system, or remotely, directly from the installer's office.

MOU and O-Box interface with the PC, enabling efficient archiving of all installations.

CODE	DESCRIPTION	PC/PACK
<b>MOTXR</b>	RADIO-CONTROLLED DIGITAL SWITCH COMPATIBLE WITH FLOR SERIES OF RECEIVERS 2 CHANNELS	1
<b>MOTXS</b>	RADIO-CONTROLLED DIGITAL SWITCH COMPATIBLE WITH SMILO SERIES OF RECEIVERS 2 CHANNELS	1
<b>MOT</b>	12-KEY, ALUMINIUM DIGITAL SWITCH, FOR COMBINATION WITH DECODER MORX	1
<b>MORX</b>	DECODER FOR 1 MOM OR 4 MOT CONNECTED IN PARALLEL WITH MEMORY BM1000 FOR 255 COMBINATIONS	1
<b>BM1000</b>	ADDITIONAL MEMORY CARD FOR OTHERS 255 COMBINATIONS	5

## TECHNICAL SPECIFICATIONS

	Power supply	Battery life	Frequency	Radiated power	Radio coding	Working temp. (°C Min/Max)	No. of figure combination	Estimated range (m)	Protection rating (IP)	Dimensions (mm)	Weight (g)
<b>MOTXR</b>	6 Vdc with 2 CR2430 type lithium batteries	estimated at 2 years, with an average number of 10 transmissions a day	433.92 MHz ± 100 KH	estimated at approximately 1 mW e.r.p.	rolling code 52 bit FloR	-20 ÷ +55	from 0 to 8	200; 35 if inside buildings	54	75x35x85 h	150
<b>MOTXS</b>					rolling code 64 bit Smilo						

	Night operation	Protection rating (IP)	Dimensions (mm)	Weight (g)
<b>MOT</b>	a red/green light will illuminate the keys	54	70x30x80 h	237

	Power supply memory	Power supply	Max. absorbed power	Protection rating (IP)	Working temp. (°C Min/Max)	Dimensions (mm)	Weight (g)
<b>MORX</b>	2 BM10000 for max. 510 MOCARD/MOCARDP FLOR-M or combinations	10÷35 Vdc, 12÷28 Vac	24 Vdc=70 mA 24 Vac=200 mA 12 Vdc=150 mA 12 Vac=300 mA (with 1 MOM or 4 MOT)	30	-20 ÷ +55	98x42x25 h	65



MOTXR, MOTXS



MOT



MORX

# MYMOONBUS

## Proximity reader for transponder cards and badge and Flor-m bimodal transmitters, with Nice BlueBUS connection technology.

### Exclusive functions:

- 255 card/badge capacity;
- 2 programming modes: Easy or Professional;
- reading distance 4-8 cm;
- enables the entry of which type of cards/badge are enabled on the system: both, MOCARD only or MOCARDP only;
- possibility of programming the number of times a specific card/badge can be used;

- possibility of enabling an automation block unblock function;
- up to 4 MOTB and MOMB control devices connectable via BlueBUS, also in combined configurations;
- 2 modes (static and dynamic) to activate two different controls selected from 6 available (for example step-step, close, open) according to the control unit connected.

**Simple installation:** easy and rapid connection with just 2 wires, no polarity, to complete the BlueBUS systems.

**Easy programming:** with MOU palmtop or O-Box interface, extremely simple management of any type of programming of the BM1000 memory in the vicinity of the system, or remotely, directly from the installer's office. MOU and O-Box interface with the PC, enabling efficient archiving of all installations.

### New transponder badge.

A practical badge that can be attached to a key-ring for availability at all times.

CODE	DESCRIPTION	PC/PACK
<b>MOMB</b>	PROXIMITY READER FOR TRANSPONDER CARDS, WITH NICE BLUEBUS TECHNOLOGY	1
<b>MOCARD</b>	TRANSPONDER CARD	10
<b>MOCARDP</b>	TRANSPONDER CARD PROGRAMMABLE VIA MOU PALM-TOP, WITH SEQUENTIAL CODE FOR MULTIPLE INSERTION	10
<b>HSB1</b>	TRANSPONDER BADGE REPROGRAMMABLE VIA MOU PALMTOP, WITH SEQUENTIAL ENCODING, FOR MULTIPLE ENTRIES	10

### TECHNICAL SPECIFICATIONS

	Power supply	Absorption	Detection range (cm)	Protection rating (IP)	Dimensions (mm)
<b>MOMB</b>	via BlueBUS	2 BlueBUS unit	from 4 to 8	55	69x26x78 h



MOCARD, MOCARDP



HSB1

# MYMOON

## Proximity sensor for transponder cards and badge and for Flor-m bimodal transmitters, with 2-wire connection to decoder.

### Exclusive functions:

- 255 cards/badge can be entered with a single code, expandable to 510;
- 2 channels;
- 2 programming modes: Easy or Professional;
- programmable output functions with instantaneous relay, bistable relay, timer, anti-theft feature;
- can be connected by cable to 1 proximity sensor;
- reading distance 5-10 cm;
- hard-wearing polycarbonate;
- LED enabling the user to see the device in the dark;



- it is possible to change the operations counter associated with a given card present in the memory;
- enables the user to change in the memory the parameter relative to the type of card/badge the decoder will be able to recognise.
- it is possible to change the code assigned to a given MOCARDP so that it can be programmed in line with specific requirements.

**Easy programming:** with MOU palmtop or O-Box interface, extremely simple management of any type of programming of the BM1000 memory in the vicinity of the system, or remotely, directly from the installer's office.

MOU and O-Box interface with the PC, enabling efficient archiving of all installations.

### New transponder badge.

A practical badge that can be attached to a key-ring for availability at all times.

CODE	DESCRIPTION	PC/PACK
<b>MOM</b>	PROXIMITY READER FOR TRANSPONDER BADGES MOCARD AND MOCARDP FOR COMBINATION WITH DECODER MORX	1
<b>MOCARD</b>	TRANSPONDER CARD	10
<b>MOCARDP</b>	TRANSPONDER CARD PROGRAMMABLE VIA MOU PALM-TOP, WITH SEQUENTIAL CODE FOR MULTIPLE INSERTION	10
<b>HSB1</b>	TRANSPONDER BADGE REPROGRAMMABLE VIA MOU PALMTOP, WITH SEQUENTIAL ENCODING, FOR MULTIPLE ENTRIES	10
<b>MORX</b>	DECODER FOR 1 MOM OR 4 MOT CONNECTED IN PARALLEL WITH MEMORY BM1000 FOR 255 COMBINATIONS	1
<b>BM1000</b>	ADDITIONAL MEMORY CARD FOR OTHERS 255 COMBINATIONS	5

### TECHNICAL SPECIFICATIONS

	Description	Anti-crushing distance (cm)	Protection rating (IP)	Dimensions (mm)	Weight (g)
<b>MOM</b>	reader for MOCARD, MOCARDP and HSB1	5 ÷ 10	55	69x26x78 h	65

	Power supply memory	Power supply	Max. absorbed power	Protection rating (IP)	Working temp. (°C Min/Max)	Dimensions (mm)	Weight (g)
<b>MORX</b>	2 BM10000 for max. 510 MOCARD/MOCARDP or combinations	10÷35 Vdc 12÷28 Vac	24 Vdc=70 mA 24 Vac=200 mA 12 Vdc=150 mA 12 Vac=300 mA (with 1 MOM or 4 MOT)	30	-20 ÷ +55	98x42x25 h	65



MOM



MOCARD, MOCARDP



HSB1



MORX

# MOONKEY

**Key switches with automatic clasp lock, European or standard cylinder.**

**Die-cast aluminium casing.**

**Ultra-thin:** just 14 mm in the recessed version (39 mm in the surface-mounted version).

**LED courtesy light** (optional).

Electrical contacts and levers protected by a plastic casing.



CODE	DESCRIPTION	PC/PACK
<b>MOSEU</b>	SURFACE-MOUNTED KEY SWITCH, EUROPEAN CYLINDER	1
<b>MOSIU</b>	RECESSED KEY SWITCH, EUROPEAN CYLINDER	1
<b>MOSE</b>	SURFACE-MOUNTED KEY SWITCH	1
<b>MOSI</b>	RECESSED KEY SWITCH	1
<b>MOSU</b>	KEY SWITCH NO EUROPEAN CYLINDER, FOR OUTDOOR USE	1

## ACCESSORIES

CODE	DESCRIPTION	PC/PACK
<b>MOSA1</b>	LED FOR MOSE, MOSI, MOSEU, MOSIU, MOSU	5
<b>CHS</b>	NEUTRAL KEY FOR MOSE, MOSI	1
<b>CHEU</b>	NEUTRAL KEY FOR MOSEU, MOSIU	1



**MOSEU**



**MOSIU**



**MOSE**



**MOSI**



**MOSU**



# MOON ACCESSORIES

## ACCESSORIES

CODE	DESCRIPTION	PC/PACK
<b>MOA1</b>	BOX FOR RECESSED INSTALLATION MOSI, MOSIU. IT IS ALSO SUITABLE FOR MOF, MOFO, MOT, MOM, MOSE, MOSEU, MOSU	20
<b>MOA2</b>	FINISHING KITS FOR INSTALLING THE MOF, MOFO, MOSE, MOSEU, MOSU, MOT, MOM SERIES OVER PRE-EXISTENT FITTINGS. THIS DOES NOT APPLY TO MOTX	3
<b>PCM</b>	FOUNDATION PLATE FOR MOCF, MOCF2, MOCs POSTS	4
<b>MOCA1</b>	INSTALLATION ACCESSORY MOSE, MOSEU, MOSU MOT, MOM ON MOCF2 POST	1
<b>MOCs</b>	ALUMINIUM POST WITH PROTECTED HOUSING FOR 1 SWITCH, 1100 mm HIGH	2
<b>MOCF2</b>	ALUMINIUM POST WITH PROTECTED HOUSING FOR 2 PHOTOCELLS, 1000 mm HIGH	2
<b>MOCF</b>	ALUMINIUM POST WITH PROTECTED HOUSING FOR 1 PHOTOCELL, 500 mm HIGH	2



**MOA1**



**MOA2**



**PCM**



**MOCA1**



**MOCs**

**MOCF2**

**MOCF**

# MOONLIGHT

**MLL version, ideal for 230 V control units without provision, connected directly to the power line, this product monitors absorption and is activated automatically when the automation starts to operate.**

**Dual function:** programmable in flashing light or courtesy light mode.

**Flashing light:** activated when an automation manoeuvre is in progress.

**Courtesy light:** activated when the automation starts to operate and, thanks to the internal timer, remains activated for a programmable time interval.

## Flashing signal light.

**Available with different power supply voltages:** 230 Vac, 24 Vdc and 12 Vdc.

**Practical:** suitable for mounting in any position.

**Incorporated 433.92 MHz aerial on all versions (except for MLL).**

IP44 protection level.

**Available in two colours: orange and neutral.**



CODE	DESCRIPTION	PC/PACK
ML	ORANGE, 230 Vac, FOR PRESET CONTROL UNITS	1
MLT	NEUTRAL, 230 Vac, FOR PRESET CONTROL UNITS	1
ML24	ORANGE, 24 Vac/Vdc, FOR PRESET CONTROL UNITS	1
ML24T	NEUTRAL, 24 Vac/Vdc, FOR PRESET CONTROL UNITS	1
MLB	ORANGE, 12 Vac/Vdc, FOR PRESET CONTROL UNITS	1
MLBT	NEUTRAL, 12 Vac/Vdc, FOR PRESET CONTROL UNITS	1
MLL	NEUTRAL, 230 Vac, FOR NON PRESET CONTROL UNITS. SUPPLIED WITH ONE WHITE LAMP AND ONE ORANGE LAMP, WITHOUT AERIAL	1

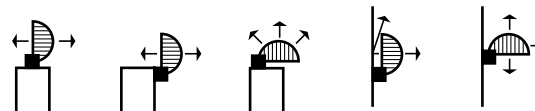

ML, ML24, MLB



MLT, ML24T, MLBT, MLL

## COMPATIBILITY TABLE

	A02	A500	A60	A700F	A924	MC824H	MC424L	WALKY	HYKE	ROAD	ROBUS	RUN	NAKED SLIDING 400	TUB	SPIN / SPINBUS	TEN	SOON	S/M/L BAR	SIGNO	WIL	
ML / MLT	.	.	.	.										.							
ML24 / ML24T					.		.												.	.	
MLB / MLBT						.	.	.	.	.	.	.	.	.	.	.	.	.	.	.	.

# WALLYGHT

**Optimal efficiency, extra long life:**  
the two 1 W-Leds guarantee a lifetime of 70.000 hours (continuous use).

**Horizontal, wall or ceiling mounting:** combined with the possibility of orienting the light beam and compact dimensions of the IP44 box, use of Wallyght is even more flexible.

## Multi-function LED indicator.

**The only version with 12/24 Vac/Vdc** power supply and flashing light function, courtesy light function or dusk sensor function.

**A new idea for improved safety:**  
when connected to compatible control units, Wallyght can act as a normal flashing light, or provide ambient lighting like a fixed courtesy light. When connected to a 12/24 Vac/Vdc output, Wallyght can remain permanently lit, and also be activated at dusk to then turn off at dawn thanks to the integrated dusk sensor.

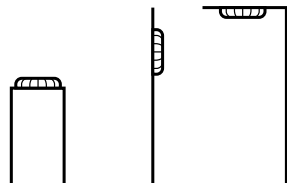

CODE	DESCRIPTION	PC/PACK
WLT	MULTI-FUNCTION LED INDICATOR	1

### PATH INDICATORS ON ENTRANCE PATHWAYS



### COURTESY LIGHT

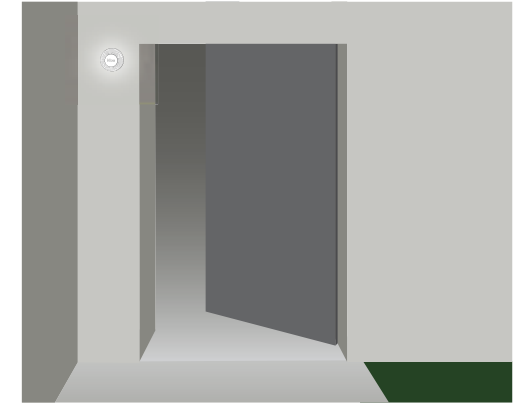

### COMPATIBILITY TABLE

	A924	MC824H	MC424L	WALKY	POP	HYKE	ROAD	ROBUS	RUN	NAKED SLIDING 400	SPIN / SPINBUS	SPIDER / SPIDO	TEN	SOON	S/M/L BAR	SIGNO	WIL
WLT	.	.	.	.	.	.	.	.	.	.	.	.	.	.	.	.	.

# KIO

**Kio, key-operated selector switch for low voltage contacts, with release mechanism for metal cord,** ideal for the automation of sectional doors, folding doors and rolling gates.

**User-friendly:**

Kio is both a key-operated selector switch and a release device. Its design makes it very convenient and effortless to use, and easy to install anywhere thanks to its very narrow outline.

**Long-lasting:** Kio is made of cast aluminium, epoxy powder coated for greater durability.

**Easy:** LED allows you to locate the selector switch even in total darkness.

**More safety:** coded key.

Release device activated directly by opening the door or by the winding device.

**The very first product to incorporate the key-operated control and release motor functions.**



KIO



KA1

CODE	DESCRIPTION	PC/PACK
KIO	KEY-OPERATED SELECTOR SWITCH FOR LOW VOLTAGE CONTACTS, WITH RELEASE MECHANISM FOR METAL CORD	1
KA1	6 m CABLE RELEASE KIT FOR KIO	1

# HEATING DEVICE

**PW1, heating element:** it maintains a suitable temperature for the automation system to operate correctly, **even under the most severe of weather conditions.**

This is a particular type of **resistance** that can reach temperatures close to 100°C under normal environmental conditions.

**Effective:** each element has a consumption of 20 W and is extremely efficient thanks to the silicone sheath that covers the resistance and increases the diffusion of heat.

**Independent:** the device is directly fed by a 230/120 Vac power supply through the TW1 thermostat, and because it doesn't burden the transformer of the product itself, the performance characteristics of the gear motor remain the same.



PW1

**TW1, regulation thermostat for PW1:**

when the detected temperature drops below the set threshold, the thermostat activates the heating element PW1 thereby slowly increasing the internal temperature of the product itself; the heating action is maintained until the detected surrounding temperature stabilizes at the set levels.

**Easy to program:** the intervention threshold can be regulated between 0°C and -20°C.

**Safe:** equipped with a button so that an operational test can be performed at any time. The status of the outputs is continuously verified by means of Leds.



TW1

CODE	DESCRIPTION	PC/PACK
PW1	HEATING ELEMENT FOR THE AUTOMATION SYSTEM	1
TW1	REGULATION THERMOSTAT	1

# PROGRAMMING UNIT

**BUPC, the programming unit** resolves “on-the-spot” control and maintenance problems of **Bio, FloR** and **VeryVR** radio control systems.

With this system you can add, cancel, check, enable or disable codes; copy the memory; enter learning and password security locks and print events.

**The software**, Windows compatible, is simple and immediate so you can use the BUPC palm-top as a local terminal.

## From the PC you can also:

- enter personal notes for each code;
- make back-up copies of the memory in the shape of files on which you can work at any time;
- enter additional codes;
- print the memory's contents;
- easy management of decoders and receivers with multiple memories;
- multiple insertion: enables the user to memorise large number of codes in just one step, simply by keying in the first and last codes.



CODE	DESCRIPTION	PC/PACK
<b>BUPC</b>	PROGRAMMING AND CODE CONTROL UNIT FOR THE FLOR, VERYVR, BIO SERIES	1

## TECHNICAL SPECIFICATIONS

	Power supply	Communication	Consumption (mA)	Dimensions (mm)
<b>BUPC</b>	9 V internal battery inside 12 Vdc external source	interface RS232 standard, 9600Bps N,8 1	10	210x100x25 h

# CONTROL UNITS



# SELECTION GUIDE

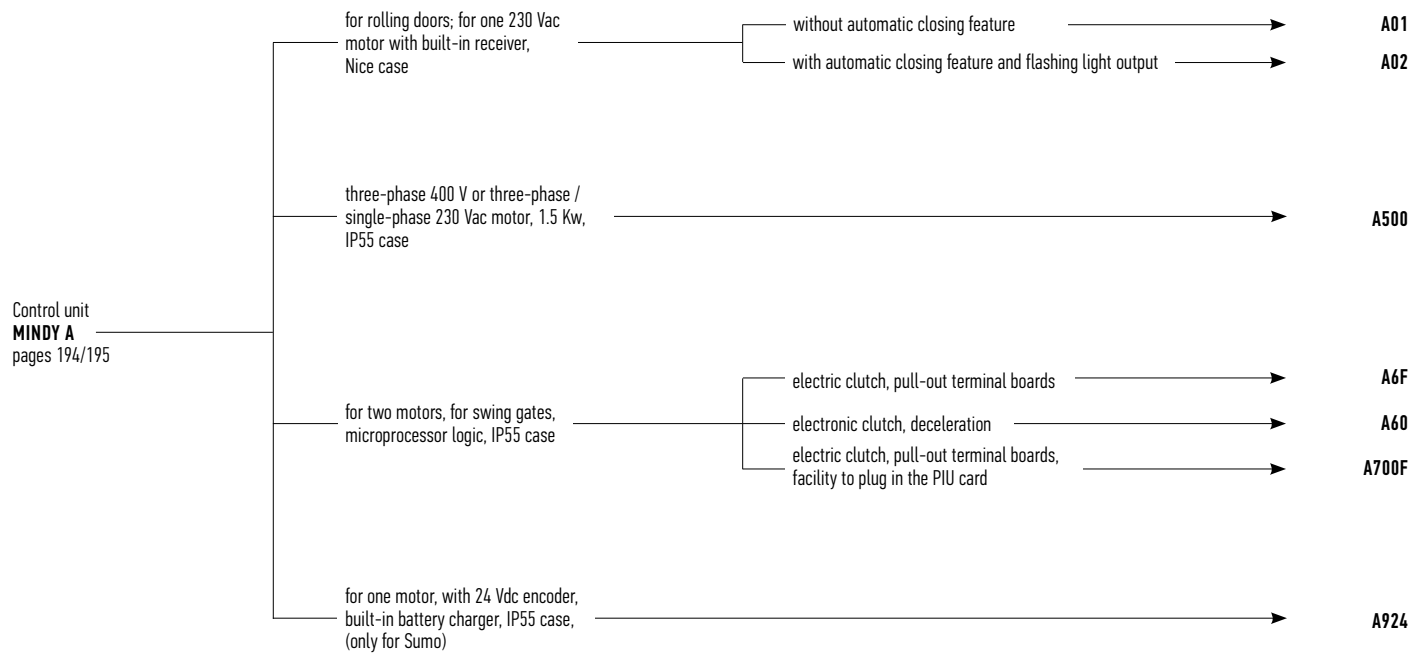
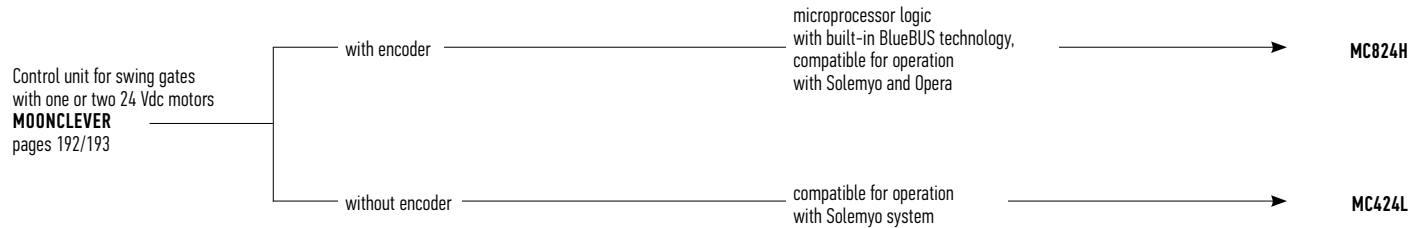

# MOONCLEVER

SOLEMYO OPERA BLUEBUS 24V

## Control unit for 24 Vdc gear motors with magnetic encoder, for swing gates.

Equipped with Nice **BlueBUS** technology and compatible with the **Solemyo** solar power system and **Opera** system for management, programming and diagnostics of automations, also remotely.

Compatible with the Opera system, which thanks to the 0-View multi-function display enables personalisation of the system, modifying the opening and closing positions, leaf offset and deceleration intervals, and diversifying parameters such as force, speed, and obstacle detection for each motor.

Microprocessor logic: in addition to the classic functions such as intelligent clutch with anti-crushing safety device, gradual start-up and deceleration, automatic memorisation of both travel limit positions and the pedestrian door function, Moonclever also offers the advantages of the Opera system.

**Safe and reliable** thanks to obstacle detection with dual technology and monitoring of motor absorption and speed via the encoder, throughout door/gate travel, with provision for connection of latest generation resistive sensitive edges.

**Intelligent:** on start-up, indicator to confirm correct power supply and efficient operation of the control unit; automatic fault diagnostics and signalling via the flashing light and confirmation leds.

**Savings, respect for the environment, and autonomy:** when connected to the buffer battery or Solemyo kit, consumption on standby is reduced to just 0.1 W.

**Installation couldn't be simpler,** thanks to the system BlueBUS, enabling connection of the control unit, motors and accessories by means of just two wires.

**No black out:** operation in the event of a power failure by means of optional batteries (PS124) with compartment in control unit.

**Radio receiver:** provision for insertion of SM snap-fit receivers.



CODE	DESCRIPTION	PC/PACK
MC824H	CONTROL UNIT FOR ONE OR TWO MOTORS AT 24 Vdc WITH ENCODER, WITH BLUEBUS TECHNOLOGY, COMPATIBLE FOR OPERA AND SOLEMYO SYSTEMS	1

## TECHNICAL SPECIFICATIONS

CODE	MC824H
POWER SUPPLY (Vac 50/60HZ)	230 ± 10%
BATTERY POWER (Vdc)	21 ÷ 28
MAXIMUM MOTOR POWER (VA; A)	360 (W); 15
MAXIMUM ACCESSORIES POWER 24 V (A)	0.2
MAXIMUM FLASHING LIGHT POWER (V;W)	12; 21
MAXIMUM GATE OPEN INDICATOR POWER CA (V; W)	24; 2
MAXIMUM ELECTRIC LOCK POWER (Vac; VA)	12; 15
WORKING TIME "TL" (S)	-
PAUSE TIME "TP" (S)	1 ÷ 250
OPENING DELAY TIME TRA (S)	PROGRAMMABLE
CLOSING DELAY TIME TRC (S)	PROGRAMMABLE
COURTESY LIGHT TIME "TCOR" (S)	0:250
PRE-FLASHING TIME "TPRE" (S)	0:10
FORCE ADJUSTMENT (%)	-
ANTI-CRUSHING DEVICE (SENSITIVITY)	MIN ÷ MAX
CASE DIMENSIONS (mm)	230x125x300 h



## ACCESSORIES



**MCA1**  
SPARE CONTROL UNIT FOR MC824H.  
PC/PACK 1



**PS324**  
24 V BATTERY WITH INTEGRATED BATTERY CHARGER.  
PC/PACK 1



# MOONCLEVER

SOLEMYO 24V

**Control unit for 24 Vdc gear motors for swing gates, without encoder.**

Compatible with the solar power kit **Solemyo**.

**Safe and reliable** thanks to obstacle detection throughout travel and provision for the connection of latest generation resistive sensitive edges.

**Intelligent:** automatic fault diagnostics and signals via flashing light and confirmation leds.

**Savings, respect for the environment, ad autonomy:** connected to the buffer battery or Solemyo kit, consumption on standby is just 0.1 W.

**No black out:** operation in the event of a power failure by means of optional batteries (PS124) with compartment in control unit.

**Radio receiver:** provision for insertion of SM snap-fit receivers.

CODE	DESCRIPTION	PC/PACK
MC424L	CONTROL UNIT FOR ONE OR TWO MOTORS AT 24 Vdc WITHOUT ENCODER, COMPATIBLE FOR SOLEMYO SYSTEM	1

## TECHNICAL SPECIFICATIONS

CODE	MC424L
POWER SUPPLY (Vac 50/60HZ)	230 ± 10%
BATTERY POWER (Vdc)	21 ÷ 28
MAXIMUM MOTOR POWER (VA; A)	75; 3
MAXIMUM ACCESSORIES POWER 24 V (A)	0.2 +0.1
MAXIMUM FLASHING LIGHT POWER (V;W)	24; 25
MAXIMUM GATE OPEN INDICATOR POWER CA (V; W)	24; 2
MAXIMUM ELECTRIC LOCK POWER (Vac; VA)	12; 15
WORKING TIME "TL" (S)	-
PAUSE TIME "TP" (S)	5 ÷ 80
OPENING DELAY TIME TRA (S)	5 ÷ 40% TL
CLOSING DELAY TIME TRC (S)	-
COURTESY LIGHT TIME "TCOR" (S)	-
PRE-FLASHING TIME "TPRE" (S)	3
FORCE ADJUSTMENT (%)	-
ANTI-CRUSHING DEVICE (SENSITIVITY)	1 ÷ 6
CASE DIMENSIONS (mm)	230x125x300 h



MC424L

## ACCESSORIES



**MCA2**  
SPARE CONTROL UNIT  
FOR MC424L.  
PC/PACK 1



**PS124**  
24 V BATTERY  
WITH INTEGRATED  
BATTERY CHARGER.  
PC/PACK 1

# MINDY A01, A02

## Mindy A01, A02 control units for rolling doors.

**Incorporated radio card** compatible with the Nice Flo, FloR and Smilo systems.

**Programmable Step-by-step/Open** input.

Input for **close** function.

Input for connection interface for 8.2 KOhm resistive sensitive edge.

Semi-automatic and automatic operation.

Flashing light output (A02 model).



CODE	DESCRIPTION	PC/PACK
<b>A01</b>	FOR ONE 230 Vac MOTOR, FOR ROLLING SHUTTERS, WITHOUT AUTOMATIC CLOSING FEATURE, WITH BUILT-IN RECEIVER COMPATIBLE WITH THE FLO, FLOR AND SMILO SERIES OF TRANSMITTERS	1
<b>A02</b>	FOR ONE 230 Vac MOTOR, FOR ROLLING SHUTTERS, WITH SEMI-AUTOMATIC AND AUTOMATIC CLOSING FEATURE, FLASHING LIGHT OUTPUT AND WITH BUILT-IN RECEIVER COMPATIBLE WITH THE FLO, FLOR AND SMILO SERIES OF TRANSMITTERS	1

### TECHNICAL SPECIFICATIONS

CODE	A01	A02
POWER SUPPLY (Vac 50/60 Hz)	230 ± 10%	
BATTERY POWER (Vdc)	-	
MAXIMUM MOTOR POWER (VA; A)	600; 3	
MAXIMUM ACCESSORIES POWER 24 V (A)	0.055	
MAXIMUM FLASHING LIGHT POWER (V; W)	-	230; 40
MAXIMUM GATE OPEN INDICATOR POWER CA (V; W)	-	
MAXIMUM ELECTRIC LOCK POWER (V; W)	-	
WORKING TIME "TL" (S)	5 ÷ 120	
PAUSE TIME "TP" (S)	-	1 ÷ 120
OPENING DELAY TIME TRA (S)	-	
CLOSING DELAY TIME TRC (S)	-	
COURTESY LIGHT TIME "TCOR" (S)	-	
PRE-FLASHING TIME "TPRE" (S)	-	
FORCE ADJUSTMENT (%)	-	
ANTI-CRUSHING DEVICE (SENSITIVITY)	-	
CASE DIMENSIONS (mm)	128x112x43 h	

# MINDY A500

## Mindy A500 control unit, three-phase 230 V, 400 V or single-phase 230 Vac motor, 1.5 Kw.

Automatic detection of obstacles, door block, brake.

Pull-out terminal boards.



PUL



CODE	DESCRIPTION	PC/PACK
<b>A500</b>	FOR A THREE-PHASE 400 Vac OR SINGLE-PHASE / THREE PHASE 230 Vac MOTOR, 1.5 KW	1
<b>PIU</b>	EXPANSION CARD FOR ADDITIONAL FUNCTIONS	1
<b>PUL</b>	CENTRAL COVER WITH INCORPORATED CONTROL BUTTONS, COMPLETE WITH CONNECTING CABLE AND CONNECTOR FOR A500 AND A924	1

### TECHNICAL SPECIFICATIONS

CODE	A500
POWER SUPPLY (Vac 50/60 Hz)	400/230 ± 10%
BATTERY POWER (Vdc)	-
MAXIMUM MOTOR POWER (VA; A)	1500; 4
MAXIMUM ACCESSORIES POWER 24 V (A)	0.2 + 0.2
MAXIMUM FLASHING LIGHT POWER (V; W)	230; 40
MAXIMUM GATE OPEN INDICATOR POWER CA (V; W)	24.2
MAXIMUM ELECTRIC LOCK POWER (V; W)	-
WORKING TIME "TL" (S)	3 ÷ 120 (210)
PAUSE TIME "TP" (S)	5 ÷ 200
OPENING DELAY TIME TRA (S)	-
CLOSING DELAY TIME TRC (S)	-
COURTESY LIGHT TIME "TCOR" (S)	(PIU)
PRE-FLASHING TIME "TPRE" (S)	5
FORCE ADJUSTMENT (%)	-
ANTI-CRUSHING DEVICE (SENSITIVITY)	MIN ÷ MAX
CASE DIMENSIONS (mm)	220x110x280 h

# MINDY A6F, A60, A700F

## Mindy A6F, A60 control units, for two motors; microprocessor logic.

Pull-out terminal boards (A6F and A60 models).  
Two photocell inputs with separate functions.  
Electrical (A6F model) or electronic (A6F and A60 models)  
adjustment.  
Gradual departure and slowdown (A60).  
Adjustment is separate to the work times (A60).



PUL

## Mindy A700F control unit, for two motors; microprocessor logic.

Removable terminal boards; two photocell inputs; four limit  
switch inputs; partial opening (standard).  
Unbeatable performance due to the many programmable  
functions.  
PIU expansion card can be inserted to provide more functions.



CODE	DESCRIPTION	PC/PACK
<b>A6F</b>	FOR TWO 230 Vac MOTORS WITH ELECTRIC CLUTCH, IP55 CASE	1
<b>A60</b>	FOR TWO 230 Vac MOTORS WITH ELECTRONIC CLUTCH AND SLOWDOWN, IP55 CASING	1
<b>A700F</b>	FOR TWO 230 Vac MOTORS WITH ELECTRIC CLUTCH. POSSIBILITY OF ADDING THE PIU EXPANSION CARD, IP55 CASE	1
<b>PIU</b>	EXPANSION CARD FOR ADDITIONAL FUNCTIONS	1
<b>PUL</b>	CENTRAL COVER WITH INCORPORATED CONTROL BUTTONS, COMPLETE WITH CONNECTING CABLE AND CONNECTOR FOR A500 AND A924	1

### TECHNICAL SPECIFICATIONS

CODE	A6F	A60	A700F
POWER SUPPLY (Vac 50/60 Hz)	230 ± 10%		
BATTERY POWER (Vdc)	-		
MAXIMUM MOTOR POWER (VA; A)	2x400; 2		
MAXIMUM ACCESSORIES POWER 24 V (A)	0.3	0.2 + 0.075	0.2 + 0.1
MAXIMUM FLASHING LIGHT POWER (V;W)	230; 100	230; 40	230; 100
MAXIMUM GATE OPEN INDICATOR POWER CA (V; W)	24; 2		
MAXIMUM ELECTRIC LOCK POWER (V; W)	12; 25		
WORKING TIME "TL" (S)	2.5 ÷ 40 (80)		
PAUSE TIME "TP" (S)	5 ÷ 80		
OPENING DELAY TIME TRA (S)	0/2.5 ÷ 12		
CLOSING DELAY TIME TRC (S)	0/2.5 ÷ 12		
COURTESY LIGHT TIME "TCOR" (S)	60	60 (PIU)	
PRE-FLASHING TIME "TPRE" (S)	5		
FORCE ADJUSTMENT (%)	30/45/60/ 80/100	0 ÷ 100	30/45/60/80/100
ANTI-CRUSHING DEVICE (SENSITIVITY)	-		
CASE DIMENSIONS (mm)	220x110x280 h		

# MINDY A924

## Mindy A924 control units (only for Sumo)

24 V version for one dc motor, complete with encoder.  
Intelligent clutch with anti-crush safety feature.  
Automatic memorization of limit switches on opening and closing;  
gradual departure and slowdown.  
Pedestrian passage function "service".  
Warning light for maintenance (can be programmed).  
Built-in battery charger. Pull-out terminal boards.



PUL



CODE	DESCRIPTION	PC/PACK
<b>A924</b>	FOR ONE MOTOR, WITH 24 Vdc ENCODER, BUILT-IN BATTERY CHARGER, IP55 CASE (ONLY FOR SUMO)	1
<b>B12-B</b>	12 V, 6 Ah BATTERIES	1
<b>B12V-C</b>	12 V, 2 Ah BATTERIES	1
<b>CARICA</b>	PLUG-IN CARD FOR BATTERY CHARGER	1
<b>BA3-A</b>	NICE BATTERY BOX FOR A924	1
<b>PUL</b>	CENTRAL COVER WITH INCORPORATED CONTROL BUTTONS, COMPLETE WITH CONNECTING CABLE AND CONNECTOR FOR A500 AND A924	1

### TECHNICAL SPECIFICATIONS

CODE	A924
POWER SUPPLY (Vac 50/60 Hz)	230 ± 10%
BATTERY POWER (Vdc)	21 ÷ 28
MAXIMUM MOTOR POWER (VA; A)	360 (W); 15
MAXIMUM ACCESSORIES POWER 24 V (A)	0.2 + 0.2
MAXIMUM FLASHING LIGHT POWER (V;W)	24/25
MAXIMUM GATE OPEN INDICATOR POWER CA (V; W)	24; 2
MAXIMUM ELECTRIC LOCK POWER (V; W)	24; 12
WORKING TIME "TL" (S) / PAUSE TIME "TP" (S)	- / 1 ÷ 1023
OPENING DELAY TIME TRA (S)	-
CLOSING DELAY TIME TRC (S)	-
COURTESY LIGHT TIME "TCOR" (S)	60
PRE-FLASHING TIME "TPRE" (S)	5
FORCE ADJUSTMENT (%)	-
ANTI-CRUSHING DEVICE (SENSITIVITY)	MIN ÷ MAX
CASE DIMENSIONS (mm)	220x110x280 h

# CONTROL UNIT FUNCTIONS

PROGRAMMABLE FUNCTIONS	A01	A02	A500	A6/A6F	A60	A700F	A924	MC824H/HK7024	MC424L	WALKY	HO2124	ROAD	ROBUS 350	ROBUS 600/1000/NAKED	RUN	SPIN10	SPIN20/21/22KCE	SPIN23	SPIN30/SN6031	SPIN40/SN6041	TN2030/TNKCE	SOON/TN2010	M-BAR/L-BAR	S-BAR	SIGN03/31/4/41/6/61	WIL4/41/6/61	
Manual operation																											
Semi-automatic operation																											
Automatic operation																											
Automatic operation + always close																											
Condominium operation																											
Pre-flashing																											
Close again 5 s after Photo																											
Photo during opening, too																											
Gradual departure																											
Gradual stop																											
Flashing even during the Pause																											
Courtesy light "on" Flashing light																											
Impulsive courtesy light																											
Gate open light (CA) with proportional flashing																											
Cancel stop during the Step-by Step cycle																											
Photocell safety when each movement starts																											
Automatic realignment when power supply returns																											
Positioning function																											
Hammering								5																			
Maintaining the pressure on oil-pressure motors																											
Activation of the Phototest																											
Skip STOP during opening																											
Skip STOP during closing																											
CLOSE becomes PEDESTRIAN OPEN																											
Photocells (PHOTO and/or PHOTO1) during opening too																											
Partial remote controlled inversion with PHOTO photocell																											
Complete remote controlled inversion with PHOTO photocell																											
Exclude limit switch																											
Standard Step-by-Step function: Open-Close-Open																											
Mode 2 Step-by-Step function: Open-Pause-Close-Open																											
Mode 3 Step-by-Step function: Open-Stop-Close-Open																											

PROGRAMMABLE FUNCTIONS	A01	A02	A500	A6/A6F	A60	A700F	A924	MC824H/HK7024	MC424L	WALKY	HO2124	ROAD	ROBUS 350	ROBUS 600/1000/NAKED	RUN	SPIN10	SPIN20/21/22KCE	SPIN23	SPIN30/SN6031	SPIN40/SN6041	TN2030/TNKCE	SOON/TN2010	M-BAR/L-BAR	S-BAR	SIGN03/31/4/41/6/61	WIL4/41/6/61	
Temporary pause (photocell)																											
Gate open light (CA) becomes "one way" traffic lights																											
Two way traffic lights																											
Step-by-Step function Open-Stop-Close-Stop																											
Extension of work time																											
Pause time with presence detector																											
1 <sup>st</sup> motor delay during opening																											
Gate Open light with limit switch																											
Brake																											
Radio card incorporated in the control unit																											
Stand-by																											



# CONNECTIONS

## WALKY

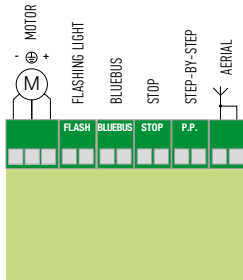

## POP 7124

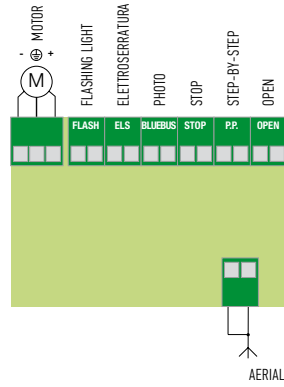

## HOPP 7124

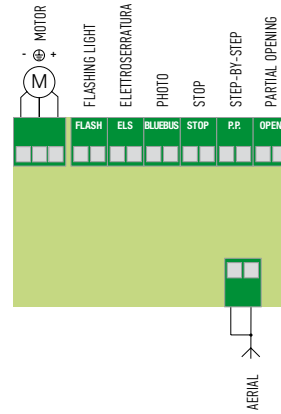

## ROBUS 400/600/1000

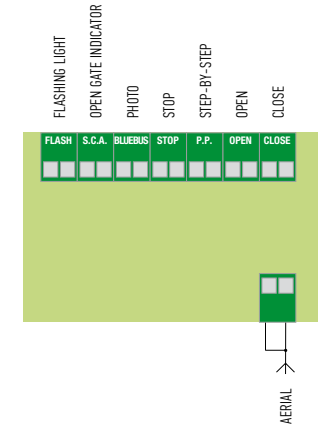

## ROAD

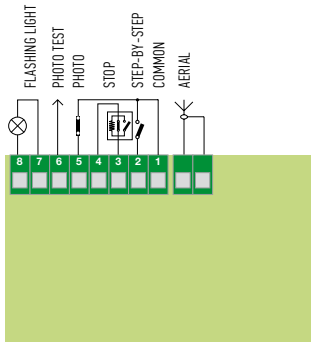

## R0300

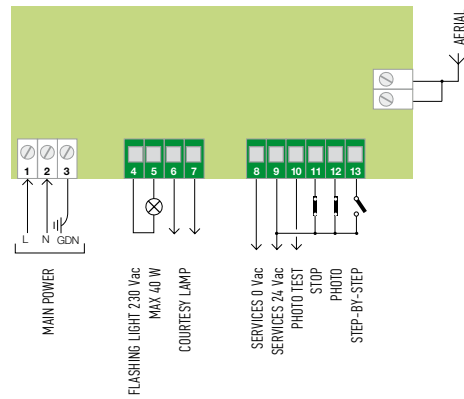

## RUN

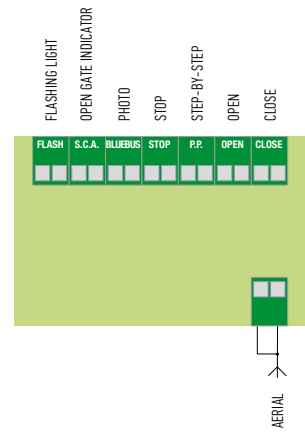

## NAKED

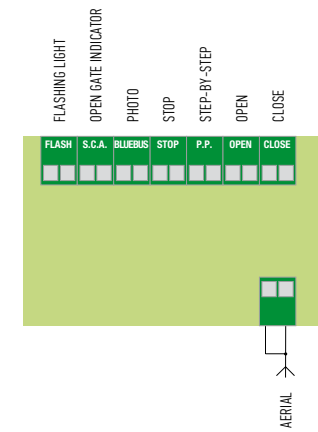

## L-BAR/M-BAR

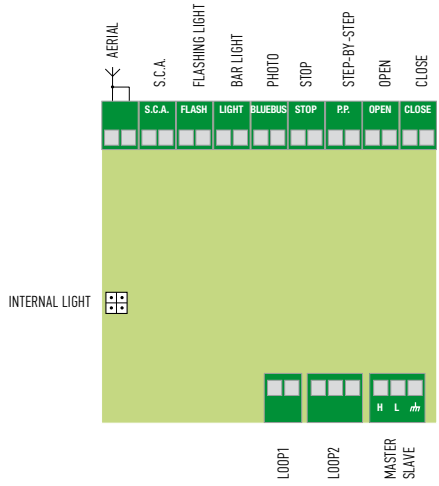

## S-BAR

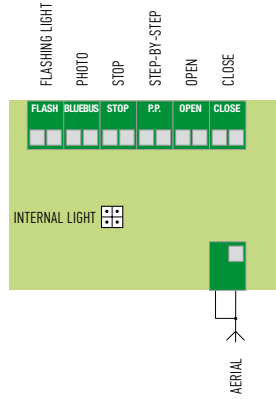

## SIGNO

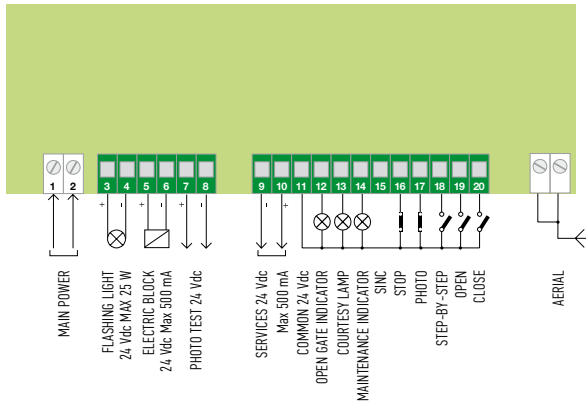

## WIL

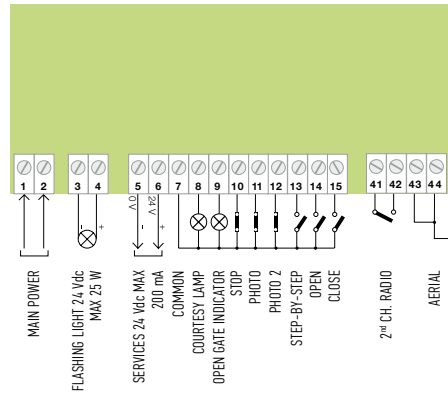

# CONNECTIONS

SPIN20KCE/SPIN21KCE/SPIN22KCE

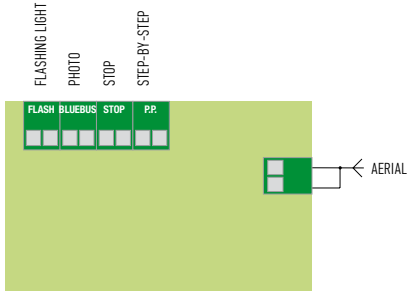

SPIN23KCE/SPIN30/SN6031/SPIN40/SN6041

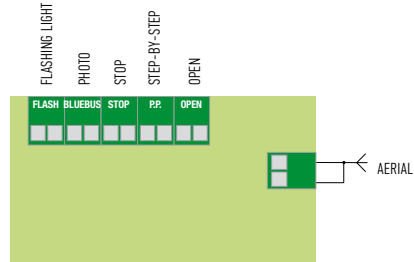

SPIN10KCE/SPIN11KCE

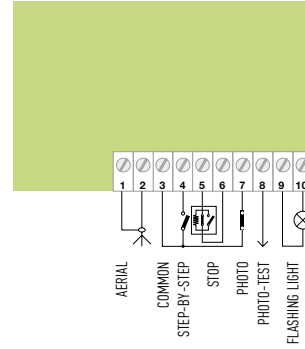

TN2010

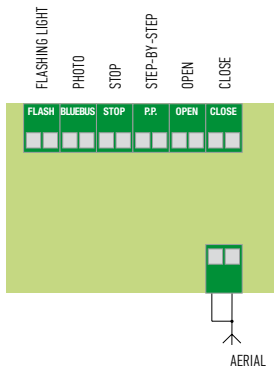

TN2030/TNKCE

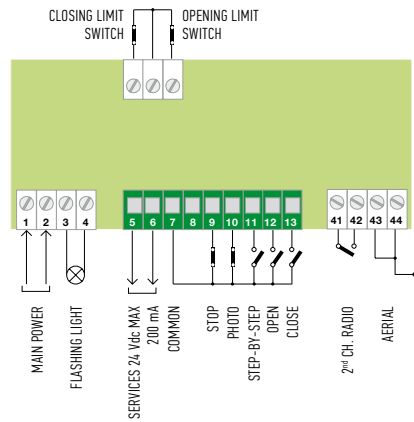

SOON

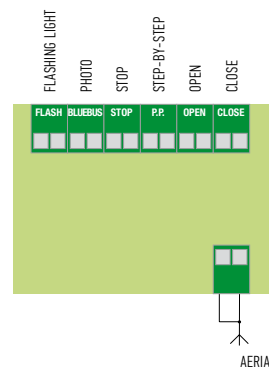



TTX4

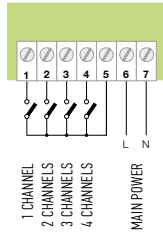

TT2N

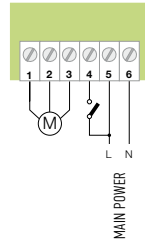

TT2L

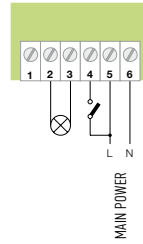

TT2D

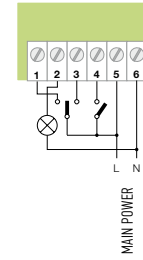

TT1N

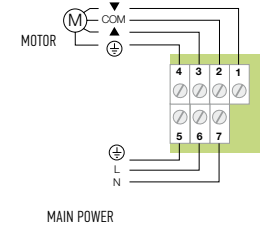

TT1L

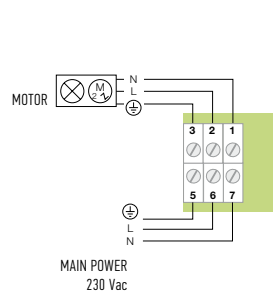

MC824H/HYKE

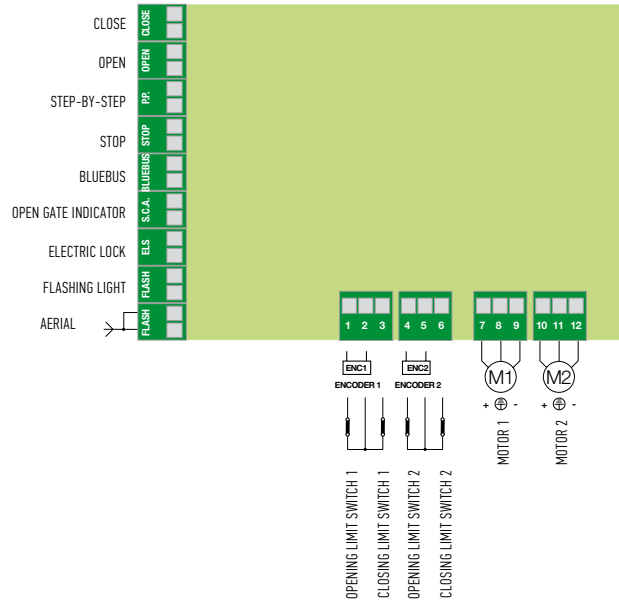

MC424L

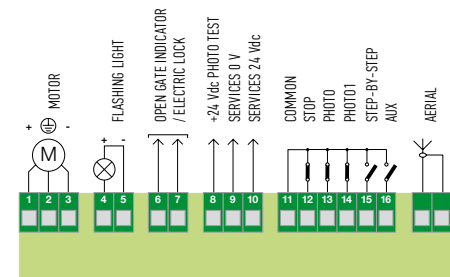

# CONNECTIONS

A0

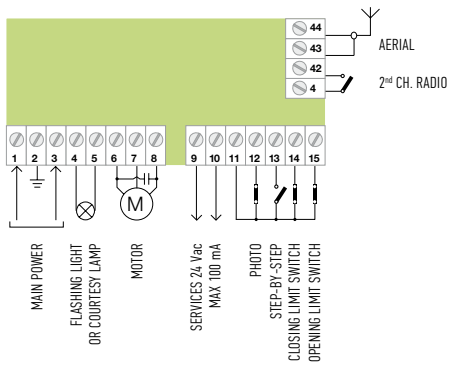

A01

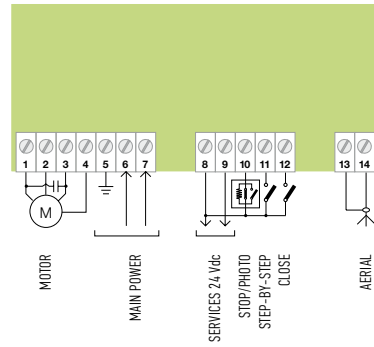

A02

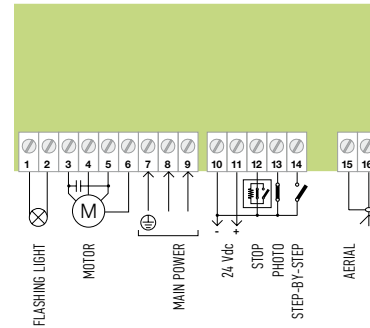

A1

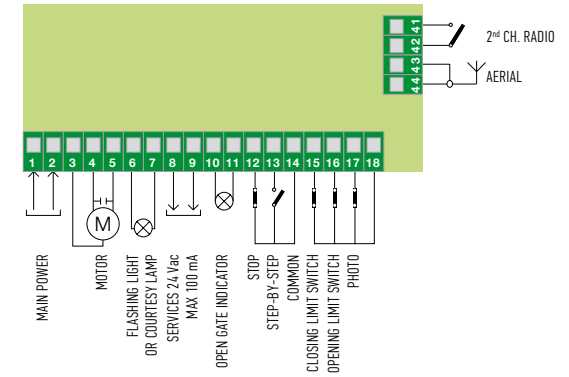

A400

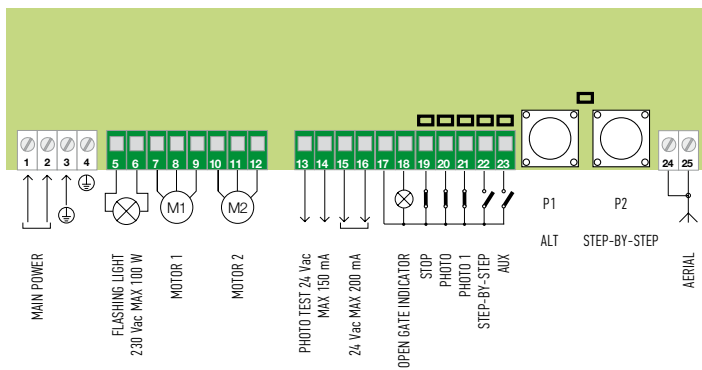

A500

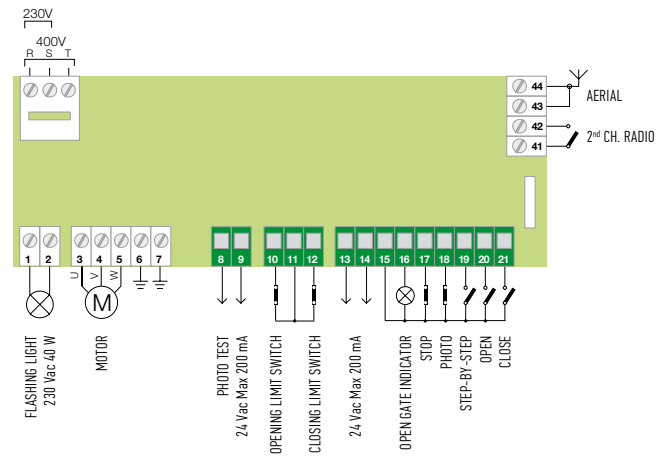

A60

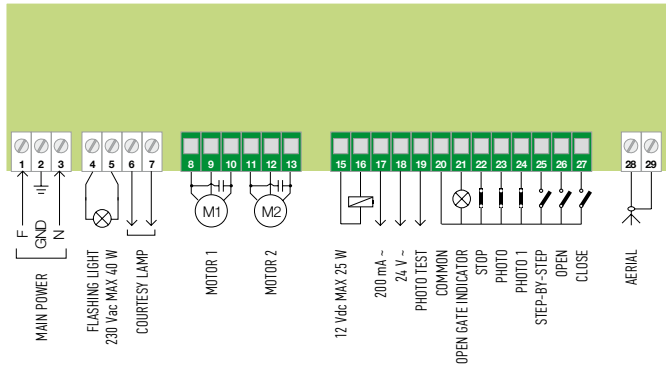

A6/A6F, A700F

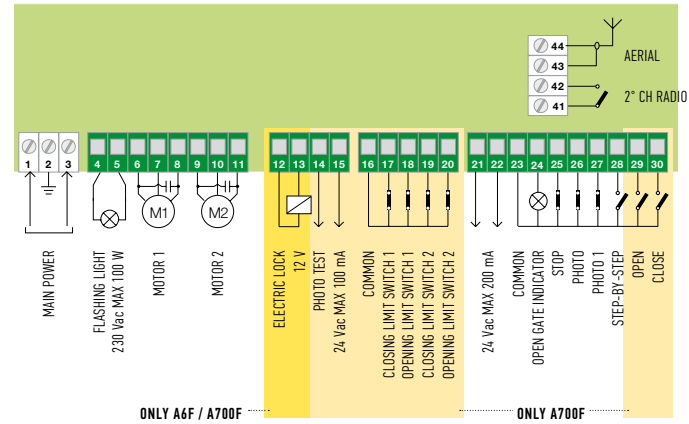

A824

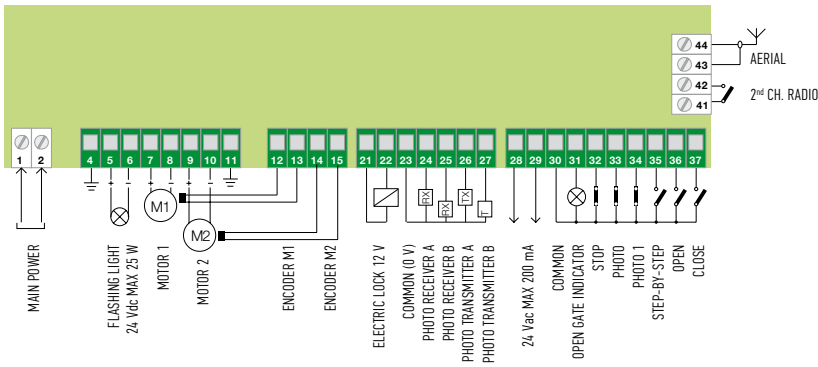

A924

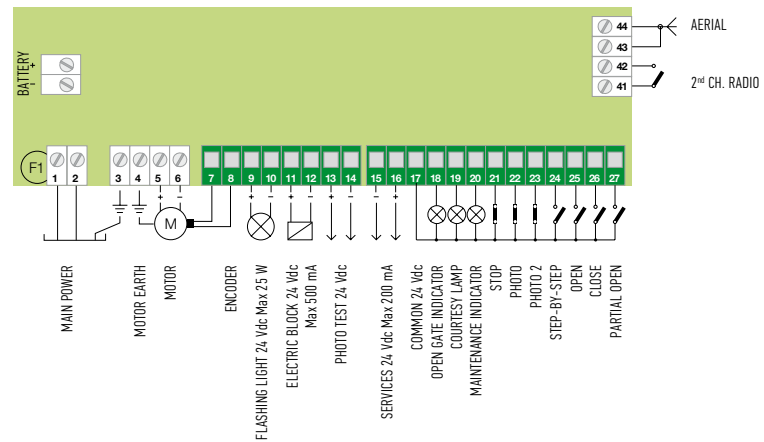

# ALPHABETICAL INDEX

CODE	PRODUCT LINE	PAGE	CODE	PRODUCT LINE	PAGE
A01	Control unit for rolling doors without automatic closing	194	CHS	Neutral key for MOSE, MOSI	184
A02	Control unit for rolling doors with automatic/ semiautomatic closing	194	CMA 1,5MT	Mechanical sensitive edges, length 1.5 m	175
A500	Control unit for a three-phase or single-phase motor	194	CMA 1,7MT	Mechanical sensitive edges, length 1.7 m	175
A6F	Control unit for two motors 230 Vac, with electric clutch, pull-out terminal boards	195	CMA 2,5MT	Mechanical sensitive edges, length 2.5 m	175
A60	Control unit for two motors with electric clutch	195	CMA 2MT	Mechanical sensitive edges, length 2 m	175
A700F	Control unit for two motors with electric clutch, possibility of adding PIU	195	CM-B	Pawl with two metal release keys	39
A924	Control unit for one motor with encoder	195	CMBK4	Kit for installing a low mechanical edge, with aluminium profiles measuring 4 m (to use together with CB)	175
ABF	Tuned directional aerial, for mounting on bracket	157	CMBK6	Kit for installing a low mechanical edge, with aluminium profiles measuring 6 m (to use together with CB)	175
ABFKIT	Tuned directional aerial, embeddable in the FLOXB2R receivers and in Lucy flashing light	157	CRA1	Mechanical accessory, shaft with 18-tooth pinion	135
ALA1	Battery charger power supply unit	162	CRA2	Mechanical accessory, joint for chain	135
B12-B	12 V, 6 Ah batteries	113	CRA3	Mechanical accessory, 1/2" chain, 1 m pack, plus joint for chain	135
B12V-D	12 V alkaline battery for transmitters	157	CRA4	Mechanical accessory, 1/2" chain, 5 m pack, plus joint for chain	135
B12V-C	12 V, 2 Ah batteries for control units	195	CRA5	Mechanical accessory, tensioner drive with brackets	135
B3V	3 V lithium battery for transmitter	157	CRA6	Mechanical accessory, 36-tooth pinion	135
B3VB	3 V lithium battery for Planotime	157	CRA7	Mechanical accessory, 18-tooth pinion	135
BA3-A	Nice battery box	135	CRA8	Mechanical accessory, wall-fixing bracket	135
BMA2	L-Fab accessory, Adapters for the installation of two motors	68	CRA9	Mechanical accessory, adapter for shafts	133
BM1000	Additional memory card (255 codes memory)	157	DBM10	Complete kit for electrical connection of sensitive edges, for gates up to 10 m	174
BM250	Additional memory card (63 codes memory)	157	DBM5	Complete kit for electrical connection of sensitive edges, for gates up to 5 m	174
BM4000	L-Fab, Motor for swing gates, underground installation, with leaves up to 4 m, with mechanical limit switch on closing	68	DBM7,5	Complete kit for electrical connection of sensitive edges, for gates up to 7.5 m	174
BM4024	L-Fab, Motor for swing gates, underground installation, with leaves up to 4 m, with encoder and mechanical limit switch on closing	68	F210	Pair of synchronised photocells, with relay output	177
BM5024	Big-Fab, Motor for swing gates, underground installation, with leaves up to 5 m, with mechanical limit switch on closing	70	F210B	Pair of synchronised photocells, with the Nice BlueBUS technology	177
BMA1	L-Fab and Big-Fab accessory, Accessory for opening up to 360°	69	FA1	Vandal-proof metal shell for optical devices	176
BMBOX	Fab accessory, Foundation box with cataphoresis paint finish	70	FA2	Bracket for fixing vandal-proof metal shell to MOCF and MOCF2 columns	176
BMBOX4	L-Fab accessory, Foundation box with cataphoresis paint finish	68	FLO1RCE	Era FloR transmitter, 1 channel, with sequential code for multiple insertion	147
BMBOX4I	L-Fab accessory, Stainless steel foundation box	68	FLO1RE	Era FloR transmitter, 1 channel	147
BMBOXI	Fab accessory, Stainless steel foundation box	70	FLO1R-S	Transmitter, 1 channel	154
BUPC	Programming and code control unit	189	FLO1R-SC	Transmitter, 1 channel, with sequential code for multiple insertion	154
CABLA01	Cable for connecting O-Box to the computer	162	FLO2RCE	Era FloR transmitter, 2 channels, with sequential code for multiple insertion	147
CABLA02	Optical reader for programming transmitters	162	FLO2RE	Era FloR transmitter, 2 channels	147
CABLA03	Cable for cloning transmitters in the series Very	162	FLO2R-M	Transmitter, 2 channels, with sequential code for multiple insertion and trasponder	155
CABLA04	Cable for cloning transmitters in the series FloR	162	FLO2R-S	Transmitter, 2 channels	154
CABLA05	Cable for programming tubular motors, equipped with port TTBUS	162	FLO2R-SC	Transmitter, 2 channels, with sequential code for multiple insertion	154
CABLA06	Cable for programming receivers universal in the series SMX and OX	162	FLO4RCE	Era FloR transmitter, 4 channels, with sequential code for multiple insertion	147
CABLA07	Cable for cloning transmitters in the series Ergo and Plano	162	FLO4RE	Era FloR transmitter, 4 channels	147
CABLA09	Cable for cloning transmitters in the series Era-Flor	162	FLO4R-M	Transmitter, 4 channels, with sequential code for multiple insertion and trasponder	155
CARICA	Plug-in card for battery charger	195	FLO4R-S	Transmitter, 4 channels	154
CB	Mechanical sensitive edges - protective rubber pad	175	FLO4R-SC	Transmitter, 4 channels, with sequential code for multiple insertion	154
CHEU	Neutral key for MOSEU, MOSIU	184	FLOX2R	Universal receiver, 2 channels with BM250 memory	157

CODE	PRODUCT LINE	PAGE
FLOXB2R	Universal receiver, 2 channels with BM250 memory for ABFKIT	157
FLOXI2R	Plug-in receiver Nice, 2 channels with BM250 memory	157
FLOXM220R	Universal modular receiver, 4 channels with an MXD channel module and BM1000 memory, 230 Vac	157
FLOXMR	Universal modular receiver, 4 channels with an MXD channel module and BM1000 memory, 24 V	157
FT210	Pair of optical devices for sensitive edges, with relay output	176
FT210B	Pair of optical devices for sensitive edges, with BlueBUS technology	176
FTA1	7 Ah battery kit for FT210/FT210B transmitters, for intensive use	176
FTA2	2 Ah battery kit for FT210/FT210B transmitters	176
HK7024	Hyke, Motor for swing gates up to 3.5 m, with articulated arm and control unit	54
HK7224	Hyke, Motor for swing gates up to 3.5 m, with articulated arm	54
HKA1	Hyke, Spare control unit for HK7024	55
HSB1	Trasponder badge for proximity reader	143
HSTS2IT	Touch screen wireless for managing Nice home automation	143
HSTSA1	Base di ricarica per touch screen completa di batterie ricaricabili	143
H07124	Hopp, Motor for swing gates up to 2.4 m, with articulated arm and control unit	50
H07224	Hopp, Motor for swing gates up to 2.4 m, with articulated arm, without control unit	50
HOPPKCE	Hopp, Kit for swing gates with leaves up to 2.4 m, externally mounted	52
HY7005	Hyppo, Motor for swing gates up to 3 m, articulated shear-proof arm, with limit switch on opening and closing	58
HY7024	Hyppo, Motor for swing gates up to 3 m, with magnetic encoder	58
HY7100	Hyppo, Motor for folding 2-leaf doors, 230 Vac, with telescopic arm and limit switch on opening and closing	136
HY7124	Hyppo, Motor for folding 2-leaf doors, 24 Vdc, with telescopic arm and limit switch on opening and closing, with magnetic encoder	136
HYA11	Hyppo, Unlock from inside with a 6 m cord	137
HYA12	Hyppo, Longer articulated arm	59
HYKEKCE	Hyke, Kit for swing gates with leaves up to 3.5 m, with articulated arm, externally mounted	56
IB	Interface for connecting F210B photocells up to control units which have not been manufactured for this purpose	177
IBW	BlueBUS wireless interface for sensitive edges	173
INB	Communication interface between Bticino Bus (SCS) and Nice Bus (TTBus and BusT4)	161
INTI1	Era Inti transmitters, 1 channel, 433,92 MHz, black	144
INTI1B	Era Inti transmitters, 1 channel, 433,92 MHz, blue	144
INTI1G	Era Inti transmitters, 1 channel, 433,92 MHz, green	144
INTI1L	Era Inti transmitters, 1 channel, 433,92 MHz, lilac	144
INTI1R	Era Inti transmitters, 1 channel, 433,92 MHz, red	144
INTI1Y	Era Inti transmitters, 1 channel, 433,92 MHz, yellow	144
INTI2	Era Inti transmitters, 2 channels, 433,92 MHz, black	144
INTI2B	Era Inti transmitters, 2 channels, 433,92 MHz, blue	144
INTI2G	Era Inti transmitters, 2 channels, 433,92 MHz, green	144
INTI2L	Era Inti transmitters, 2 channels, 433,92 MHz, lilac	144
INTI2R	Era Inti transmitters, 2 channels, 433,92 MHz, red	144
INTI2Y	Era Inti transmitters, 2 channels, 433,92 MHz, yellow	144

CODE	PRODUCT LINE	PAGE
INTIKIT	Era Inti, Kit composed by three 2-channel transmitters Era Inti (red, green, blue) and one receiver OX2	144
IRW	Wireless relay interface for sensitive edges	173
KA1	6 m cable release kit for KIO	188
KIO	Key-operated selector switch for low voltage contacts with release mechanism for metal cord	188
LBAR	Road barrier system for bars from 7 to 9 m, steel case with protective cathoporesis treatment	102
LBARI	Road barrier system for bars from 7 to 9 m, stainless steel case	102
LLW	Wireless flashing light with built-in photovoltaic panel	172
LP1	Single-channel metal mass detector 24 V power supply	175
LP2	Two-channel metal mass detector 24 V power supply	175
M3BAR	Road barrier system for bars of 3 m, steel case with protective cathoporesis treatment	98
M3BARI	Road barrier system for bars of 3 m, stainless steel case	98
M5BAR	Road barrier system for bars of 4 or 5 m, steel case with protective cathoporesis treatment	98
M5BARI	Road barrier system for bars of 4 or 5 m, stainless steel case	98
M7BAR	Road barrier system for bars of 5, 6 or 7 m, steel case with protective cathoporesis treatment	98
M7BARI	Road barrier system for bars of 5, 6 or 7 m, stainless steel case	98
MC424L	Control unit for swing gates with one or two 24 Vdc motors, with Solemyo technology	193
MC824H	Control unit for 24 Vdc Toona	192
MCA1	Spare control unit for MC824H	192
MCA2	Spare control unit for MC424L	193
ME3000	X-Fab, Motor for swing gates with leaves up to 3 m, 230 Vac, underground installation, high speed	66
ME3000L	X-Fab, Motor for swing gates with leaves up to 3 m, 230 Vac, underground installation, low speed	66
ME3024	X-Fab, Motor for swing gates with leaves up to 3 m, 24 Vdc	66
MEA1	Mechanical accessory for opening up to 360° for gates max. 2.5 m in length	67
MEA2	Fab accessory, Key unlock system	67
MEA3	Fab accessory, Lever-type key unlock system	67
MEA5	Fab accessory, Lever-type unlock key for MEA3	67
MEA6	Fab accessory, Limit switch bracket	67
MECF	Fab accessory, Externally chamfered foundation box with cathoporesis finish with mechanical stop on opening	66
MECX	Fab accessory, Externally chamfered foundation box in stainless steel with mechanical stop on opening	66
ML	Moonlight, Orange flashing signal light, 230 Vac, for preset control unit	186
ML24	Moonlight, Orange flashing signal light, 24 Vac/Vdc, for preset control unit	186
ML24T	Moonlight, Neutral flashing signal light, 24 Vac/Vdc, for preset control unit	186
MLB	Moonlight, Orange flashing signal light, 12 Vac/Vdc, for preset control unit	186
MLBT	Moonlight, Neutral flashing signal light, 12 Vac/Vdc, for preset control unit	186
MLL	Moonlight, Neutral flashing signal light, 230 Vac, for preset control unit. White and orange lamp	186
MLT	Moonlight, Neutral flashing signal light, 230 Vac, for preset control unit	186
MOA1	Moon Accessory, Box for recessed installation of Moon Series	185
MOA2	Moon Accessory, Finishing kits for installing of the Moon Series	185
MOCA1	Moon Accessory, Installation accessory MOSE, MOSEU, MOSU MOT, MOM on MOCF2 post	185

# ALPHABETICAL INDEX

CODE	PRODUCT LINE	PAGE
<b>MOCARD</b>	Transponder card for proximity reader	<b>182</b>
<b>MOCARDP</b>	Transponder card for proximity reader, programmable via MOU palm-top	<b>182</b>
<b>MOCF</b>	Aluminium post for 1 photocell, 500 mm high	<b>176</b>
<b>MOCF2</b>	Aluminium post for 2 photocells, 1000 mm high	<b>176</b>
<b>MOCS</b>	Aluminium post with protected housing for 1 switch, 1100 mm high	<b>185</b>
<b>MOF</b>	Pair of surface-mounted photocells	<b>179</b>
<b>MOFB</b>	Surface-mounted pair of photocells for connection by Nice BlueBUS	<b>178</b>
<b>MOF0</b>	Pair of adjustable 30°, surface-mounted photocells	<b>179</b>
<b>MOF0B</b>	Pair of adjustable 30°, surface-mounted photocells, for connection by Nice BlueBUS	<b>178</b>
<b>MOM</b>	Proximity reader for transponder badges MOCARD and MOCARDP	<b>183</b>
<b>MOMB</b>	Proximity reader for transponder cards, with Nice BlueBUS technology	<b>182</b>
<b>MORX</b>	Decoder for 1 MOM or 4 MOT connected in parallel with memory BM1000 for 255 combinations	<b>181</b>
<b>MOSA1</b>	Led for MOSE, MOSI, MOSEU, MOSIU, MOSU	<b>184</b>
<b>MOSE</b>	Surface-mounted key switch	<b>184</b>
<b>MOSEU</b>	Surface-mounted key switch, European cylinder	<b>184</b>
<b>MOSI</b>	Recessed key switch	<b>184</b>
<b>MOSIU</b>	Recessed key switch, European cylinder	<b>184</b>
<b>MOSU</b>	Key switch no European cylinder, for outdoor use	<b>184</b>
<b>MOT</b>	12-key, aluminium digital switch, for combination with decoder MORX	<b>181</b>
<b>MOTB</b>	12-key digital selector, in aluminium, with Nice BlueBUS technology	<b>180</b>
<b>MOTXR</b>	Radio-controlled digital switch compatible with FloR series of receivers 2 channels	<b>181</b>
<b>MOTXS</b>	Radio-controlled digital switch compatible with Smilo series of receivers 2 channels	<b>181</b>
<b>MXD</b>	Impulsive channel units for the modular receivers	<b>157</b>
<b>MXP</b>	Step-by-step channel units for the modular receivers	<b>157</b>
<b>MXT</b>	Adjustable timer from 3 seconds to 5 minutes channel unit	<b>157</b>
<b>NKSL400</b>	Naked, Concealed motor for swing gates up to 400 kg, with control unit and absolute encoder	<b>76</b>
<b>NSEA</b>	Instrument for force impact measurement, angular extension	<b>174</b>
<b>NSEL</b>	Instrument for force impact measurement, straight extension	<b>174</b>
<b>NSFB</b>	Instrument for force impact measurement compliant with EN12445- BlueForce	<b>174</b>
<b>NSFS</b>	Instrument for force impact measurement compliant with EN12445- SpeedForce	<b>174</b>
<b>NSSWPDA</b>	BlueForce PDA software for Pocket-PC, for force impact measurement, for NSFB	<b>174</b>
<b>OBOX2</b>	Connection interface complete with software "O-Box Software Suite", with USB connection cable supplied	<b>162</b>
<b>OBOX2B</b>	Connection interface complete with software "O-Box Software Suite", with USB connection cable and integrated Bluetooth module	<b>162</b>
<b>ON1CE</b>	Era One transmitter, 1 channel, 433,92 MHz, with sequential code for multiple insertion	<b>146</b>
<b>ON1E</b>	Era One transmitter, 1 channel, 433,92 MHz	<b>146</b>
<b>ON1EFM</b>	Era One transmitter, 1 channel, 868,46 MHz	<b>146</b>
<b>ON2CE</b>	Era One transmitter, 2 channels, 433,92 MHz, with sequential code for multiple insertion	<b>146</b>
<b>ON2E</b>	Era One transmitter, 2 channels, 433,92 MHz	<b>146</b>
<b>ON2EFM</b>	Era One transmitter, 2 channels, 868,46 MHz	<b>146</b>

CODE	PRODUCT LINE	PAGE
<b>ON4CE</b>	Era One transmitter, 4 channels, 433,92 MHz, with sequential code for multiple insertion	<b>146</b>
<b>ON4E</b>	Era One transmitter, 4 channels, 433,92 MHz	<b>146</b>
<b>ON4EFM</b>	Era One transmitter, 4 channels, 868,46 MHz	<b>146</b>
<b>ON9E</b>	Era One transmitter, 9 channels, 433,92 MHz	<b>146</b>
<b>ON9EFM</b>	Era One transmitter, 9 channels, 868,46 MHz	<b>146</b>
<b>OTA11</b>	Mechanical accessory, Kit for external unlocking with a metal cord	<b>129</b>
<b>OTA12</b>	Mechanical accessory, Kit for external unlocking with key ratchet	<b>129</b>
<b>OTA2</b>	Mechanical accessory, Motor support bracket (1250 mm long)	<b>129</b>
<b>OTA3</b>	Mechanical accessory, Motor support bracket (2000 mm long)	<b>129</b>
<b>OTA9</b>	Mechanical accessory, Motor support bracket (520 mm long)	<b>129</b>
<b>OVA1</b>	0-View Accessory, Clamp for fitting connectors RJ14	<b>160</b>
<b>OVA2</b>	0-View Accessory, Connectors RJ14, type 6/4, for flat 4-wire cable	<b>160</b>
<b>OVA3</b>	0-View Accessory, RJ14 splitters, type 6/4, for cascade connection	<b>160</b>
<b>OVA4</b>	0-View Accessory, Flat 4-wire cable for connection of devices	<b>160</b>
<b>OVB1</b>	0-View, Bluetooth module for 0-View and software for PC, PDA or Smartphone	<b>160</b>
<b>OVB1GSM</b>	0-View, GSM module and software for PC, PDA or Smartphone	<b>160</b>
<b>OVIEW</b>	Unit for control, programming and diagnostics of devices equipped with BUS T4 connection	<b>160</b>
<b>OX2</b>	Prewired receiver 433,92 MHz, 2 channels, without built-in transmitter	<b>148</b>
<b>OX2FM</b>	Prewired receiver 868,46 MHz, 2 channels, without built-in transmitter	<b>148</b>
<b>OX2T</b>	Prewired receiver 433,92 MHz, 2 channels, with built-in transmitter	<b>148</b>
<b>OX2TFM</b>	Prewired receiver 868,46 MHz, 2 channels, with built-in transmitter	<b>148</b>
<b>OX4T</b>	Universal receiver 433,92 MHz, 4 channels, with built-in transmitter	<b>148</b>
<b>OXI</b>	Receiver with connector, 433,92 MHz, 4 channels, without built-in transmitter	<b>148</b>
<b>OXIFM</b>	Receiver with connector, 868,46 MHz, 4 channels, without built-in transmitter	<b>148</b>
<b>OXIT</b>	Receiver with connector, 868,46 MHz, 4 channels, with built-in transmitter	<b>148</b>
<b>OXITFM</b>	Prewired receiver 868,46 MHz, 4 channels, with built-in transmitter	<b>148</b>
<b>PCM</b>	Moon accessory, Foundation plate for MOCF, MOCF2, MOCS posts	<b>185</b>
<b>PHW</b>	Wireless photocells with built-in photovoltaic panel	<b>172</b>
<b>PHWA1</b>	Pair of adapters for PHW on PPH1 posts	<b>172</b>
<b>PIU</b>	Expansion card for additional functions of control unit	<b>90</b>
<b>PLA10</b>	Mechanical accessory, Vertical 12 V electric lock	<b>31</b>
<b>PLA11</b>	Mechanical accessory, Horizontal 12 V electric lock	<b>31</b>
<b>PLA13</b>	Mechanical accessory, Mechanical travel stops for closing and opening manoeuvres	<b>31</b>
<b>PLA14</b>	Mechanical accessory, Screw-adjustable rear bracket	<b>31</b>
<b>PLA15</b>	Mechanical accessory, Screw-adjustable front bracket	<b>31</b>
<b>PLA6</b>	Mechanical accessory, Rear bracket 250 mm long	<b>31</b>
<b>PLA8</b>	Mechanical accessory, Screw-adjustable front bracket	<b>33</b>
<b>PLANOTIME</b>	Wall-mounted radio-control timer with LCD graphic display, can manage up to 6 automation units	<b>156</b>
<b>PO</b>	Support bracket for MOF and MOFB photocells	<b>109</b>

CODE	PRODUCT LINE	PAGE
POA3	Spare control unit for H07124	41
PPH1	ERA classic column 50 cm	172
PS124	24 V battery with integrated battery charger	41
PS224	24 Vdc buffer battery	100
PS324	24 V battery with integrated battery charger (for motor in 24Vdc version)	31
PS424	Buffer battery	47
PSY24	24 V battery box with control circuit and carry handle	171
PUL	Central cover with incorporated control buttons, complete with connecting cable and connector for A500	135
PW1	Heating element for the automation system	188
RB1000	Robus, Motor for sliding gates up to 1000 kg with control unit and electromechanical limit switch	78
RB1000P	Robus, Motor for sliding gates up to 1000 kg with control unit and inductive limit switch	78
RB400	Robus, Motor for sliding gates up to 400 kg with control unit and electromechanical limit switch	78
RB400KCE	Robus, Kit for sliding gates up to 400 kg with control unit and electromechanical limit switch	80
RB600	Robus, Motor for sliding gates up to 600 kg with control unit and electromechanical limit switch	78
RB600KCE	Robus, Kit for sliding gates up to 600 kg with control unit and electromechanical limit switch	82
RB600P	Robus, Motor for sliding gates up to 600 kg with control unit and inductive limit switch	78
RBA1	Accessory for sliding gates, Inductive limit switch	79
RBA3	Robus accessory, Spare control unit for RB400, RB600/600P, RB1000/1000P and RUN1500/1500P	79
RBA4	Road accessory, Spare control unit for RDKCE	85
RDKCE	Road, Kit for sliding gates up to 400 kg and leaves up to 6 m, with control unit and receiver	84
RN2010	Rondo, Reversible motor without brake for balanced rolling doors up to 130 kg	138
RN2020	Rondo, Reversible motor without brake for balanced rolling doors up to 180 kg	138
RN2030	Rondo, Irreversible motor with brake and release device for balanced rolling doors up to 130 kg	138
RN2040	Rondo, Irreversible motor with brake and release device for balanced rolling doors up to 180 kg	138
RNA01	Rondo Accessory, Electronic brake for RN2020 and RN2010	139
ROA6	M4 25x20x1000 mm slotted nylon rack with metal insert for gates weighing up to 500 kg.	91
ROA7	M4 rack, zinc coated, 22x22x1000 mm	91
ROA8	M4 rack, 30x8x1000 mm, zinc coated with spacers and screws	91
ROA81	M6 rack, 30x30x1000 mm, zinc coated, to be coupled with RUA12	91
RUA1	Spare control unit for RUN1800/1800P and RUN2500/2500P	89
RUA12	12-teeth pinion, module 6, to be coupled with rack ROA81	87
RUA2	Run accessory, Spare control unit for RUN2500I	89
RUA3	Run accessory, Spare inverter for RUN2500I	89
RUN1500	Run, Motor for sliding gates up to 1500 kg, with control unit and electromechanical limit switch	86
RUN1500P	Run, Motor for sliding gates up to 1500 kg, with control unit and inductive limit switch	86
RUN1800	Run, Motor for sliding gates up to 1800 kg, with control unit and electromechanical limit switch	88
RUN1800P	Run, Motor for sliding gates up to 1800 kg, with control unit and inductive limit switch	88
RUN2500	Run, Motor for sliding gates up to 2500 kg, with control unit and electromechanical limit switch	88
RUN2500I	Run, Motor for sliding gates up to 2500 kg, with control unit, inverter and electromechanical limit switch	88

CODE	PRODUCT LINE	PAGE
RUN2500P	Run, Motor for sliding gates up to 2500 kg, with control unit and inductive limit switch	88
SBAR	Bar system for bars up to 4 m, with steel case with protective cathaphoresis treatment and paint finish	96
SBARI	Bar system for bars up to 4 m, with stainless steel case	96
SIA1	BAR accessory, Anchorage base with clamps	97
SIA2	SIGN06/SIGN06I accessory, Anchorage base with clamps	109
SIA20	Spare control unit	109
SIA3	SIGN03/SIGN03I accessory, Aluminium bar, painted white 36x73x3250 mm	108
SIGN03	Road barrier system for bars up to 3 m, galvanised steel, painted case	106
SIGN03I	Road barrier system for bars up to 3 m, satin stainless steel case	106
SIGN04	Road barrier system for bars up to 4 m, galvanised steel, painted case	106
SIGN04I	Road barrier system for bars up to 4 m, satin stainless steel case	106
SIGN06	Road barrier system for bars up to 6 m, galvanised steel, painted case	106
SIGN06I	Road barrier system for bars up to 6 m, satin stainless steel case	106
SMX2R	Universal pre-wired receiver, 2 channels, with memory containing 256 codes- Smilo coding	157
SMXI	Universal pre-wired receiver, 2 channels, with memory containing 256 codes- Flo coding	157
SN6031	Spinbus, Motor for sectional doors and up-and-over garage doors, with built-in control unit, 800 N	120
SN6041	Spinbus, Motor for sectional doors and up-and-over garage doors, with built-in control unit, 1000 N	120
SNA1	Spinbus accessory, Spare control unit for SPIN10KCE and SPIN11KCE	127
SNA16	Spinbus accessory, Quick-connect brackets for ceiling mounting	119
SNA2	Spinbus accessory, Spare control unit for SPIN20KCE, SPIN21KCE and SPIN22KCE	123
SNA20	Spinbus accessory, Spare control unit for SPIN23KCE	125
SNA3	Spinbus accessory, Spare control unit for SPIN30/SN6031	119
SNA30	Spinbus accessory, Preassembled 3 m guide	120
SNA31	Spinbus accessory, 1 m extension for guide SNA30	120
SNA4	Spinbus accessory, Spare control unit for SPIN40/SN6041	119
SO2000	Soon, Motor for sectional door up to 5 m, with absolute encoder	132
SOA2	Soon accessory, Spare control unit SO2000	133
SPA2	Spinbus accessory, Kit for unlocking from the outside with cable	119
SPA5	Spinbus accessory, Oscillating arm sliding on bearings with optimised structure for projecting up-and-over doors	119
SPA6	Spinbus accessory, Large 585 mm long connecting arm	119
SPA7	Spinbus accessory, Kit of two additional fixing brackets	119
SPIN10KCE	Spinkit, For sectional doors up to 8.8 m <sup>2</sup> and up-and-over up to 9.8 m <sup>2</sup> . Guide in one 3-metre section	126
SPIN11KCE	Spinkit, For sectional doors up to 8.8 m <sup>2</sup> and up-and-over up to 9.8 m <sup>2</sup> . 3 m pre-assembled guide	126
SPIN20KCE	Spinbuskit, For sectional doors up to 10.5 m <sup>2</sup> and up-and-over up to 11.8 m <sup>2</sup> . Guide in one 3-metre section	122
SPIN21KCE	Spinbuskit, For sectional doors up to 10.5 m <sup>2</sup> and up-and-over up to 11.8 m <sup>2</sup> . 3 m pre-assembled guide	122
SPIN22KCE	Spinbuskit, For sectional doors up to 10.5 m <sup>2</sup> and up-and-over up to 11.8 m <sup>2</sup> . Guide in one 3-metre section + one 1-metre section	122
SPIN23KCE	Spinbuskit, For sectional doors up to 10.5 m <sup>2</sup> and up-and-over up to 11.8 m <sup>2</sup> . 3 m pre-assembled guide. Compatible with Solemyo and Opera	124
SPIN30	Spinbus, For sectional doors up to 12.5 m <sup>2</sup> and up-and-over up to 11.8 m <sup>2</sup> , 800 N	118
SPIN40	Spinbus, For sectional doors up to 12.5 m <sup>2</sup> and up-and-over up to 11.8 m <sup>2</sup> , 1000 N	118

# ALPHABETICAL INDEX

CODE	PRODUCT LINE	PAGE	CODE	PRODUCT LINE	PAGE
SU2000	Sumo, For sectional doors and two-wings sliding doors up to 35 m <sup>2</sup>	134	TOONA4024KCE	ToonaKit, Kit for swing gates with leaves up to 3 m, surface mounted	36
SU2000V	Sumo, For sectional doors and two-wings sliding doors up to 25 m <sup>2</sup> , high speed	134	TS	Signboard	31
SU2000VV	Sumo, For sectional doors and two-wings sliding doors up to 15 m <sup>2</sup> , super high speed	134	TT1L	Control unit for installations for lighting/irrigation systems, with radio receiver, IP55 protection	167
SU2010	Sumo, For sectional doors and two-wings sliding doors up to 35 m <sup>2</sup> , IP54	134	TT1N	Control unit for a 230 Vac motor, with radio receiver, IP55 protection	167
SYA1	Solemyo accessory, Power supply unit for charging the battery PSY24 from the supply mains	171	TT2D	Control unit for installations for 230 Vac lighting systems, with receiver and switching module	166
SYKCE	Solar power kit comprising SYP photovoltaic panel and PSY24 battery box with charging control circuit	171	TT2L	Control unit for installations for 230 Vac lighting systems, with receiver	166
SYP	Photovoltaic panel for 24 V supply with maximum power 15 W	171	TT2N	Miniaturized control unit for a 230 Vac motor, with radio receiver	166
SYP30	Photovoltaic panel for 24 V supply with maximum power 30 W	171	TTX4	Recessed transmitter, 4 channels, with mains power	165
TCA65	Sensitive edges accessory, Aluminium profile L=200 cm	174	TUB3500	Tub, Motor for sliding gates up to 3500 kg, with built-in Mindy A500 control unit	90
TCB65	Sensitive edge in 10 m rolls	174	TW1	Regulation thermostat for PW1	188
TCBS60	Passive sensitive edge in 10 m rolls	175	WA1	SIGN04/4l accessory, Aluminium bar, painted white 36x73x4250 mm	108
TCE	Sensitive edge accessory, Control interface for sensitive edge	174	WA10	Bars accessory, Red adhesive reflector strips	97
TCF	Sensitive edge accessory, Scissors for cutting safety sensitive edges	174	WA11	Bars accessory, Adjustable stand for bars	97
TCK	Sensitive edge accessory, Kit for 8 sensitive edges composition	174	WA12	Bars accessory, Mobile stand for bars	101
TCW1	Sensor for sensitive edge with wireless technology and battery power supply	173	WA13	Bars accessory, Aluminium rack (2 m) for WA1, WA21, WA22	101
TCW2	Sensor for sensitive edge with wireless technology and PV power supply	173	WA14	SIGN04/4l accessory, Joint for rods WA1 (from 1850 mm to 2400 mm)	108
TN2010L	Ten, Upgraded motor for projecting and non projecting up-and-over doors, with control unit, absolute encoder and BlueBUS	128	WA15	WIL4/4l accessory, Anchorage base with clamps	112
TN2020L	Ten, Upgraded motor for projecting and non projecting up-and-over doors, without control unit	128	WA16	WIL6/6l accessory, Anchorage base with clamps	112
TN2030L	Ten, Upgraded motor for projecting and non projecting up-and-over doors, with control unit and receiver, mechanical limit switch	128	WA2	Bars accessory, 8 m pack of red shockproof rubber strip with caps to close	108
TNA1	Ten accessory, Spare control unit for TN2030, TN2030L, TNKCE and TNLKCE	129	WA20	Spare control unit	113
TNA2	Ten accessory, Spare control unit for TN2010L	129	WA21	Bars accessory, Aluminium bar, painted white 36x94x6250 mm	109
TNA38	Ten accessory, Driving device for transmission shafts	129	WA22	Bars accessory, Modular bar, plus joint painted white, 2 sections 36x94x3125 mm	109
TNA4	Ten accessory, 20x20 mm drive shaft (1500 mm long)	129	WA24	Bars accessory, Tubular telescopic bar in white painted aluminium, max. length 8 m	109
TNA5	Ten accessory, Pair of standard straight telescopic arms	129	WA25	Bars accessory, Pivoting connection for rettangular bars up to 4 m	108
TNA6	Ten accessory, Pair of standard curved telescopic arms	129	WA3	Bars accessory, Tubular aluminium bar, painted white Ø 70x4250 mm	108
TNA8	Ten accessory, 20x20 mm drive shaft (200 mm long)	129	WA4	Bars accessory, Connection for the WA3 bar	108
TNA9	Ten accessory, Additional connection cable and supports for wall-mounting of PS324 battery	129	WA6	Bars accessory, 12 m pack of red, shockproof, rubber strip with caps to close	109
TNLKCE	Ten, Upgraded kit for projecting and non projecting up-and-over doors with control unit, receivers and mechanical limit switch	130	WA7	Bars accessory, Tubular aluminium bar, painted white Ø 90x6250 mm	109
TO4005	Toona, Motor for swing up to 3 m, with limit switch on opening, high speed	30	WA8	Bars accessory, Connection for the WA7 bar	109
TO4006	Toona, Motor for swing up to 3 m, with limit switch on opening and closing, high speed	30	WA9	Bars accessory, Pack of flashing signals, wired for WA1, WA21, WA22 bars	109
TO4015	Toona, Motor for swing up to 3 m, with limit switch on opening, low speed	30	WALKY1024KCE	Walky, Kit for swing gates with leaf up to 1.8 m	46
TO4024	Toona, Motor for swing up to 3 m, mechanical stop on opening	30	WALKY2024KCE	Walky, Kit for swing gates with leaf up to 1.8 m, with MOFB e MOSE	48
TO4605	Toona, Motor for swing up to 3 m, limit switch on opening, high speed	30	WAX	Ondo, Table holder for Nice Way, white plastic + Ice Blue rubber	152
TO5015	Toona, Motor for swing up to 5 m, with limit switch on opening, low speed	32	WCF	Go, Mini cover for NiceWay, fern green	153
TO5016	Toona, Motor for swing up to 5 m, with limit switch on opening and closing, low speed	32	WCG	Go, Mini cover for NiceWay, graphite	153
TO5024	Toona, Motor for swing up to 5 m, mechanical stop on opening	32	WCI	Go, Mini cover, Ice Blue	153
TO5024I	Toona, Motor for swing up to 5 m, mechanical stop on opening, for intensive use	32	WCO	Go, Mini cover, orange	153
TO5605	Toona, Reversible motor for swing up to 5 m, limit switch on opening, high speed	32	WEO	Stone, Table shockproof holder, orange	152
TO7024	Toona, Motor for swing up to 7 m, mechanical stop on opening and closing	34	WET	Stone, Table shockproof holder, neutral transparent	152



CODE	PRODUCT LINE	PAGE
WEW	Stone, Table shockproof holder, white	152
WIL4	Wil, Bar system for bars up to 4 m, with galvanised steel painted case	110
WIL4I	Wil, Bar system for bars up to 4 m, with satin stainless steel case	110
WIL6	Wil, Bar system for bars up to 6 m, with galvanised steel painted case	110
WIL6I	Wil, Bar system for bars up to 6 m, with satin stainless steel case	110
WING04024KCE	Wingo, Kit for swing gates with leaves up to 2 m, 24 Vdc, surface mounted	40
WING05024KCE	Wingo, Kit for swing gates with leaves up to 3.5 m, 24 Vdc, surface mounted	44
WING05KCE	Wingo, Kit for swing gates with leaves up to 3.5 m, 24 Vdc, surface mounted, with A60	42
WING0KCE/A60	Wingo, Kit for swing gates with leaves up to 2 m, with A60	38
WLA1	Walky accessory, Spare control unit for WL1024C	47
WLT	Wallyght, Multi-function Led indicator	187
WM001C	Niceway, Single channel module to control 1 automation system	151
WM001G	Niceway, Module to control 1 Open-Stop-Close automation system	151
WM002G	Niceway, Module to control 2 Open-Stop-Close automation systems	151
WM003C	Niceway, Three channel module to control 3 automation systems	151
WM003C1G	Niceway, Module to control 3 Step-by-Step and 1 Open-Stop-Close automation systems	151
WM003G	Niceway, Module to control 3 Open-Stop-Close automation systems	151
WM004G	Niceway, Module to control 4 Open-Stop-Close automation systems and sun sensor activation command	151
WM006G	Niceway, Module to control 6 Open-Stop-Close automation systems	151
WM009C	Niceway, Nine channel module to control 9 Step-by-Step automation systems	151
WM080G	Niceway, Module to control 80 Open-Stop-Close automation systems and sun sensor activation command	151
WM240C	Niceway, Module to control 240 Step-by-Step automation systems	151
WRA	Opla, Rectangular wall plate, aluminium	153
WRB	Opla, Rectangular wall plate, black	153
WRG	Opla, Rectangular wall plate, graphite	153
WRS	Opla, Rectangular wall plate, seawater	153
WRT	Opla, Rectangular wall plate, neutral transparent	153
WRW	Opla, Rectangular wall plate, white	153
WSA	Opla, Squared wall plate, aluminium	153
WSB	Opla, Squared wall plate, black	153
WSG	Opla, Squared wall plate, graphite	153
WSS	Opla, Squared wall plate, seawater	153
WST	Opla, Squared wall plate, neutral transparent	153
WSW	Opla, Squared wall plate, white	153
WWW	Ondo, Magnetic wall support for Ondo	152
XBA10	Bars accessory, Pivoting connection for bars up to 4 m	100
XBA11	Joint for bars XBA15 and XBA14 (from 1950 mm to 2400 mm)	100
XBA13	Bars accessory, Rubber impact protection strip	97
XBA14	Bars accessory, White paint-finished aluminium bar 69x92x4150 mm	101

CODE	PRODUCT LINE	PAGE
XBA15	Bars accessory, White paint-finished aluminium bar 69x92x3150 mm	100
XBA16	Bars accessory, Anchorage base with clamps	100
XBA17	Bars accessory, Anchorage base with clamps	103
XBA18	Bars accessory, Indicator lights for click fixture on upper or lower side of bar. Length 8 m	101
XBA19	Bars accessory, White paint-finished aluminium bar 45x58x4000 mm	97
XBA20	Spare control unit for SBAR	97
XBA3	Spare control unit	100
XBA4	Bars accessory, Indicator lights for click fixture on upper or lower side of bar	97
XBA5	Bars accessory, White paint-finished aluminium bar 69x92x5150 mm	101
XBA6	Bars accessory, Indicator lights for click fixture on upper or lower side of bar. Length 6 m	101
XBA7	Bars accessory, Integrable flashing light	97
XBA8	Bars accessory, Integrable traffic light	100
XBA9	Bars accessory, Expansion joint	101
XMBOX	Fab accessory, Externally foundation box, with cataphoresis paint finish	60
XME2024	X-Fab, Motor for swing gates with leaves up to 2.3 m, underground installation	60
XME2124	X-Fab, Motor for swing gates with leaves up to 2.3 m with encoder, underground installation	60
XMETRO2024KCE	X-Fab, Kit for swing gates with leaves up to 2.3 m, underground installation	62
XMETRO2124KCE	X-Fab, Kit for swing gates with leaves up to 2.3 m, underground installation, BlueBUS, compatible with Opera	64





# NICE IS THE SIMPLEST INTEGRATION/ THE WIDEST RANGE/THE BEST CONTROL ELECTRONICS/THE FINEST DESIGN/THE MOST AMUSING AUTOMATION ALL TOGETHER!

## GATE&DOOR

Systems for the automation of gates, garage doors and barriers.

## SCREEN

Systems for the automation of blinds, awnings and sun screens. The easiest way to get the right light.

## INDUSTRIAL DOORS

Systems for the automation of industrial applications: sectional and rolling doors, high speed doors and dock levellers.

## PARK SYSTEMS

Systems for the management of off-street car-parks. Versatile, flexible and complete. Born fully grown!

## HOME SYSTEMS

Integrated management of home alarm and automation systems.



**Nice**

Nice SpA  
Oderzo TV Italia  
Ph. +39.0422.85.38.38  
info@niceforyou.com

Find out more about Nice products and services on the website:  
[www.niceforyou.com](http://www.niceforyou.com)



Nice cares for the environment. Using natural paper it avoids excessive use of raw materials and forest exploitation. Waste is reduced, energy is saved and climate quality is improved.