

EN TRANSLATION OF THE ORIGINAL INSTALLATION AND OPERATING MANUAL

Sliding gate operator SP 900

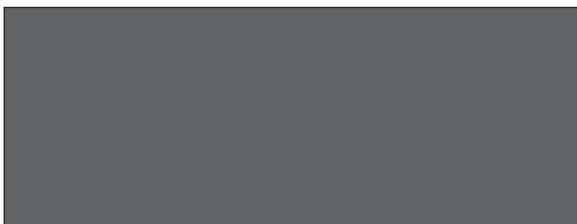

Download the current manual:



Somloq
Rollingcode

Table of contents

General Information	3	Commissioning/operation	23
Symbols.....	3	Rest control unit	23
Safety instructions	3	Programming	23
Intended use.....	4	Safety instructions	24
Permitted gate wing dimensions	4	Radio receiver (version Somloq Rollingcode)	24
Technical data	4	Radio receiver (version SOMloq2)	25
Max. traction/pressure force	4	Completing commissioning	28
Dimensions.....	5	Safety instructions	28
Installation preparations.....	6	Opening the gate.....	28
Safety instructions	6	Closing the gate	28
Tools required.....	6	Defined opening and closing	28
Personal protective equipment.....	6	Partial opening	28
Scope of supply.....	6	Automatic closing function.....	29
Package 1	6	Dead man operation.....	29
Package 2	7	Obstacle detection.....	30
Tips for installation.....	8	Power-saving mode.....	30
Installation.....	9	Overload protection	31
Foundation	9	Operation after a power failure	31
Installation of column.....	9	Emergency release	31
Installing the operator.....	11	Maintenance and care	32
Installing the racks.....	12	Safety instructions	32
Adjusting the tooth play	13	Regular testing	32
Connection.....	14	Troubleshooting	33
Safety instructions	14	Description of the flash sequences of the LEDs.....	33
Installation location.....	14	Disassembly and disposal.....	34
Mains connection	15	Disassembly	34
Connecting safety devices	15	Disposal.....	34
Connecting button	17	Warranty and customer service.....	34
Optional connections.....	18	DIP switch settings.....	35
Connection/commissioning	19	Wiring diagram	36
Battery pack	19		
Safety instructions	21		
Connecting the power supply	21		
Installing limit switches	21		

General Information

Symbols



ATTENTION SYMBOL:

Important safety instructions!

Attention – to ensure personal safety, it is important to observe all instructions. Save these instructions!



IMPORTANT INFORMATION SYMBOL:

Information, useful advice!

1 (1) Refers to a respective picture in the introduction or main text.

Safety instructions

General

- These installation and operating instructions must be read, understood and complied with by persons who install, use or perform maintenance on the operator.
- Keep this installation and operating manual accessible at all times.
- Installation, connection and initial commissioning of the operator may only be carried out by technically knowledgeable persons.
- Install the operator on correctly aligned gates only. An improperly aligned gate can cause serious injuries or damage the operator.
- The manufacturer assumes no liability for injuries, damage or breakdowns that occur due to non-compliance with the installation and operating instructions.
- Always ensure compliance with accident prevention regulations and current standards in each respective country.
- Observe and comply with the "ASR A1.7 Technical Regulations for Workplaces" of the German Committee for Workplaces (ASTA), which is mandatory for the operator in Germany.
- Before any work on the operator disconnect it from the power supply and lock it to prevent reconnection. This also includes disconnection of a battery, if present.
- All electrical wiring must be firmly secured to prevent displacement
- Only use OEM (Original Equipment Manufacturer) spare parts, accessories and mounting material.

Storage

- The operator must be stored in an enclosed, dry area at a room temperature of $-20\text{ }^{\circ}\text{C}$ to $+50\text{ }^{\circ}\text{C}$.
- The operator should be stored horizontally.

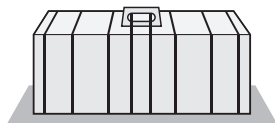
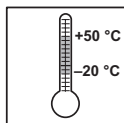

Operation

- The operator must be operated only if a non-hazardous force tolerance is set or safety is guaranteed by other safety equipment. The force tolerance must be set low enough to eliminate any danger of injury by the closing force (see "Maintenance and care").
- Never put your hand near the gate when it is moving or near moving parts.
- Drive through the gate only when it has opened completely.
- There is a risk of persons being crushed or cut by the mechanism or sharp edges of the gate.
- For automatic closing the main and auxiliary closing edges must be secured in accordance with the applicable directives and standards.
- Open and close the gate only if there are no children, persons, animals, or objects within its range of motion.
- Regularly check the safety and protection functions and repair faults when they are detected. See Care and maintenance.

Radio remote control

- The remote control must only be used for devices and systems in which radio interference will not endanger people, animals or objects or the risk is reduced by other safety devices.
- The user must be made aware that systems that pose an accident risk should only be remote controlled, if at all, if the user can actually see the gate.
- The radio remote control may only be used if the gate's movement can be watched and no persons or objects are within the range of movement.
- Store the hand-held transmitter so that unintended operation, e.g., by children or animals, is impossible.
- The operator of the radio system is not protected from faults due to other telecommunications equipment or devices (e.g. radio-controlled systems that are licensed to operate in the same frequency range). If substantial interference occurs, please contact your appropriate telecommunications office which has radio interference measuring equipment (radiolocation).
- Do not operate the handheld transmitter in areas with sensitive radio communications or systems (e.g. airports, hospitals).

Type plate

- The type plate is attached to the inside of the base frame/housing. The type plate shows the exact type designation and the date of manufacture (month/year) of the operator.

General Information

Intended use

- The operator is exclusively intended to open and close sliding gates (see EN 12433-1). Any other use does not constitute intended use. The manufacturer accepts no liability resulting from use other than intended use. The user bears the sole responsibility for any risk involved. The warranty expires as a result.
- Gates automated with an operator must comply with all currently valid standards and directives: e.g. EN 12604, EN 12605.
- Maintain the safety clearances between the gate and surroundings as specified in EN 12604.
- The operator must be in good technical condition, and it must be used for its intended purpose with awareness of the hazards as described by the installation and operating manual.
- Position the running rail to allow water to drain to prevent ice accumulation in winter.
- The gate must move freely in the guide and on the running rail to allow the operator to react sensitively and the gate to be switched off in emergency.
- The gate must have end stops in open and closed position, otherwise it may be pushed out of the guide in the event of an emergency release.
- Malfunctions which could affect safety must be corrected immediately.
- The gate must be stable and rigid, meaning that it may not bend or twist when being opened or closed.
- The operator cannot compensate for defects in the gate or incorrect assembly or installation.
- Do not install operator in explosive areas.
- Do not operate operator in rooms with aggressive atmosphere.

Simplified Declaration of Conformity

SOMMER Antriebs- und Funktechnik GmbH hereby declares that the radio system (SP 900) complies with Directive 2014/53/EU. You can see the full text of the EU Declaration of Conformity for the radio system at:



<https://som4.me/mrl>

Permitted gate wing dimensions

min. path:	1,400 mm	
max. path:	8,000 mm	
	Gate weight	Incline

Depends on the installed shaft

Standard shaft	Max. 250 kg	3.5 %*
	251–400 kg	0 %
Extended shaft Adjustment range 50 mm	Max. 400 kg	0 %
Extended shaft Adjustment range 100 mm	Max. 300 kg	0 %

* Gates operated in combination with a **SP 900**, must not have an inclination of more than 3.5 % and must comply with the valid standards and directives, in particular EN 12604. Radial dampers are recommended with lift gates. However, these merely optimise speed regulation and do not in any way guarantee safety.

Technical data

Rated voltage	AC 220–240 V
Rated frequency	50–60 Hz
Storage locations in radio receiver	112* 40/450**
Operating temperature range	–20 °C to +60 °C
IP code	Operator: IP44 control unit: IP64
Max. torque	10 Nm
Rated torque	3 Nm
Rated wattage	46 W
Max. speed	285 mm/s
Power consumption, standby	0.5 W
Operating time	S3 40 %

Workplace-related emission value <75 dB(A) – operator only.

* 112 Somloq Rollingcode

** 40 SOMloq2 (Memo 450)

Max. traction/pressure force

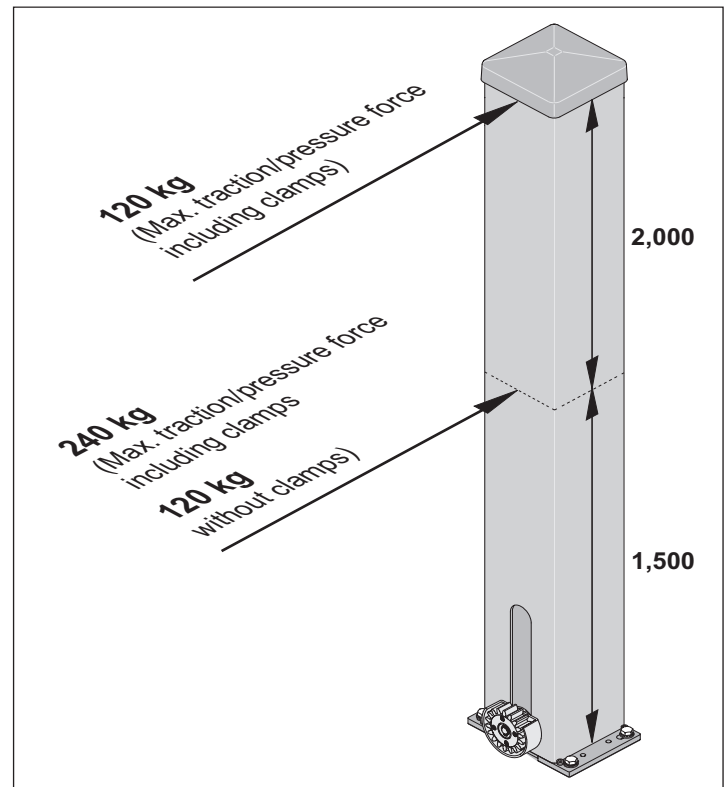

General Information

Dimensions

All dimensions are in millimetres. The operator is locked.

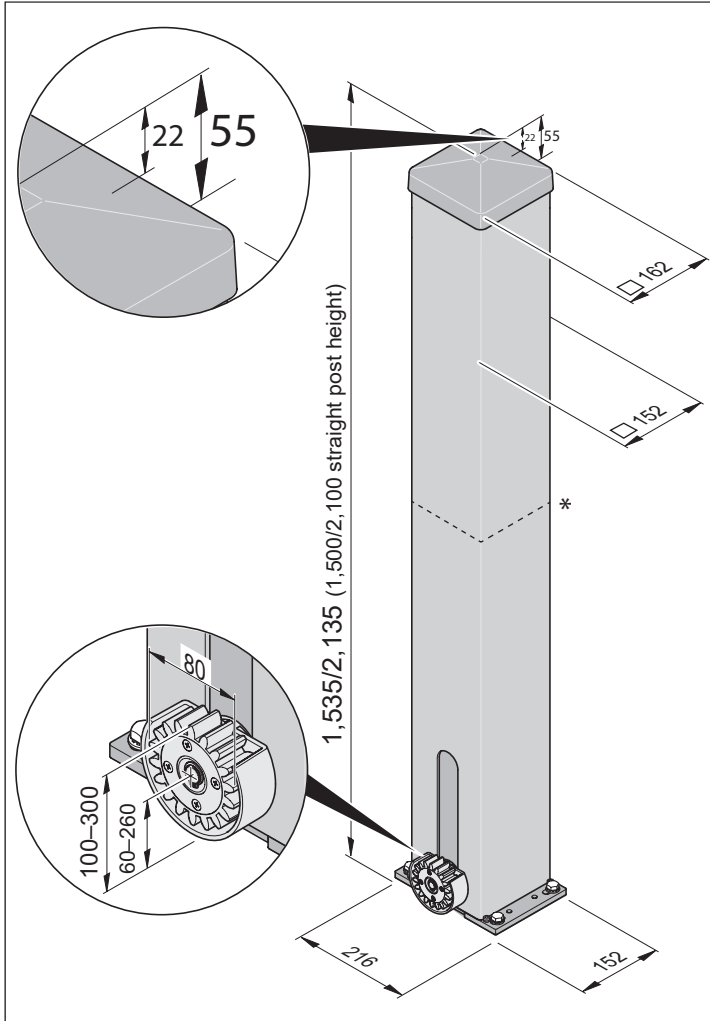

* Minimum height: 800 mm.

Declaracion of incorporation

for the installation of an incomplete machine in accordance with the Machinery Directive 2006/42/EC, Appendix II, Section 1 B

SOMMER Antriebs- und Funktechnik GmbH

Hans-Böckler-Straße 27

73230 Kirchheim/Teck

Germany

hereby declares that the operator

SP 900

was designed, developed and manufactured in compliance with

- Machinery Directive 2006/42/EC
- Low Voltage Directive 2014/35/EU
- Directive on Electromagnetic Compatibility 2014/30/EU
- RoHS Directive 2011/65/EU.

The following norms were used:

- EN ISO 13849-1, PL "C" Cat. 2 Safety of machines – Safety-related parts of controls – Part 1: General design guidelines
- EN 60335-1/2, where applicable Safety of electrical appliances/operators for gates
- EN 61000-6-3 Electromagnetic compatibility (EMC) – interference
- EN 61000-6-2 Electromagnetic compatibility (EMC) – interference resistance
- EN 60335-2-103 General safety requirements for household and similar electrical appliances – Part 2: Special requirements for operators for gates, doors and windows

The following requirements of Annex 1 of the Machinery Directive 2006/42/EC are met:

1.1.2, 1.1.3, 1.1.5, 1.2.1, 1.2.2, 1.2.3, 1.2.4, 1.2.6, 1.3.2, 1.3.4, 1.3.7, 1.5.1, 1.5.4, 1.5.6, 1.5.14, 1.6.1, 1.6.2, 1.6.3, 1.7.1, 1.7.3, 1.7.4

The special technical documentation was prepared in accordance with Annex VII Part B and will be submitted to regulators electronically on request.

The incomplete machine is intended for installation in a gate system only to form a complete machine as defined by the Machinery Directive 2006/42/EC. The gate system may only be put into operation after it has been established that the complete system complies with the regulations of the above EC Directive.

The undersigned is responsible for compilation of the technical documents.

Kirchheim,
20.04.2016



i.V.

Jochen Lude
Responsible for documents

Installation preparations

Safety instructions



ATTENTION!

Follow all installation directions. Improper installation may cause serious injuries.

- The mains voltage must correspond with the voltage listed on the operator type plate.
- The contacts of all devices to be connected externally must be safely isolated from the mains voltage supply according to IEC 60364-4-41.
- Wires for external devices must be installed in accordance with IEC 60364-4-41.
- The operator may only be installed, connected and commissioned by qualified technicians.
- Do not move the gate if there are people, animals or objects in the area of movement.
- Keep children, disabled persons and animals away from the gate.
- Wear safety glasses when drilling the fastening holes.
- Cover the operator during drilling to prevent penetration of dirt.



ATTENTION!

The foundation must be solid and stable. Only install the operator on a correctly aligned gate. An incorrectly aligned gate could cause serious injury.

- Gates must be stable in themselves, since high traction and compression forces are encountered. Reinforce lighter gates made of plastic or aluminium if necessary before installation. Ask a specialist retailer for advice.
- Remove or disable gate locks.
- Use only approved fasteners (e.g. anchor fittings, bolts). The fasteners must match the material of the ground.
- Check that the gate runs smoothly.

Tools required

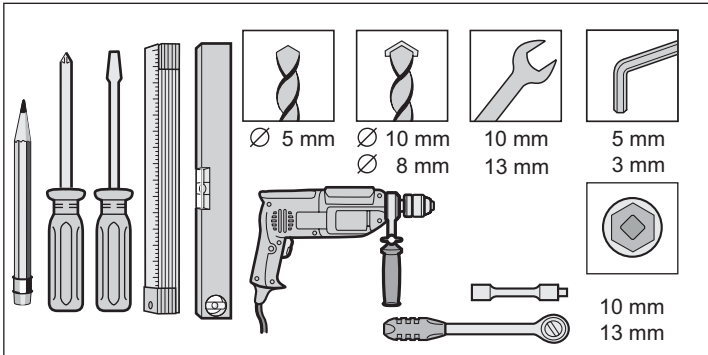

Personal protective equipment

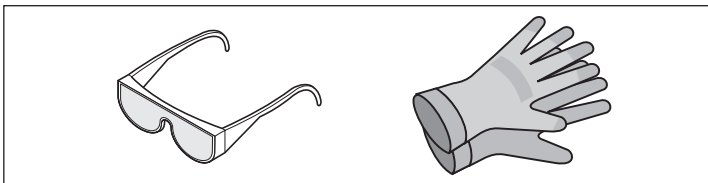

- Safety glasses (for drilling).
- Work gloves.

Scope of supply

- Check the package before installation to avoid unnecessary work and expense if a part is missing.
- The actual scope of supply may vary depending on the operator version.

Package 1

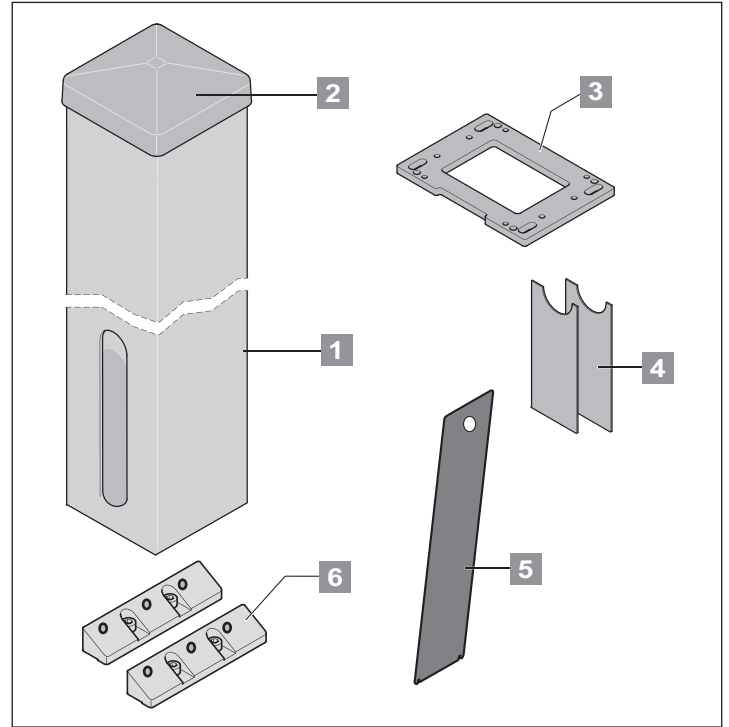

Package 1

Post 1,500 mm high

Package (l x w x h)	2.350 mm x 210 mm x 165 mm	
Weight	11.8 kg	
1	1 pc	Post
2	1 pc	Post cover
3	1 pc	Baseplate
4	2 pcs	Cover for height adjustment
5	1 pc	Revision flap

Package 1

Post 2,100 mm high

Package (l x w x h)	2.350 mm x 210 mm x 165 mm	
Weight	20 kg	
1	1 pc	Post
2	1 pc	Post cover
3	1 pc	Baseplate
4	2 pcs	Cover for height adjustment
5	1 pc	Revision flap
6	2 pcs	Clamping claws

Installation preparations

Package 2

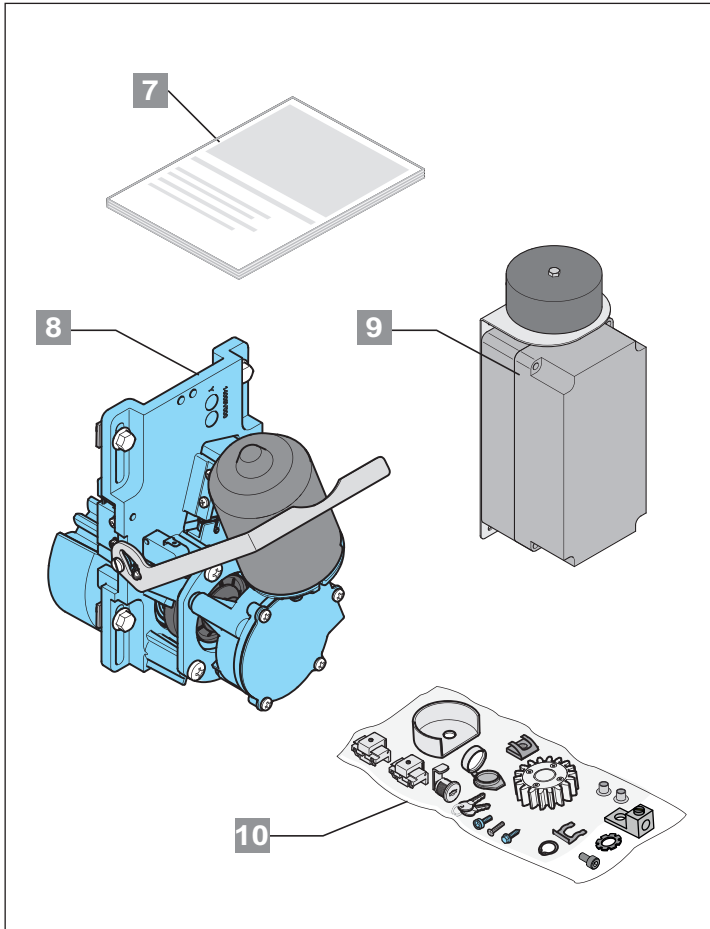

Package 2

Package (l x w x h)	800 mm x 180 mm x 155 mm	
Weight	7.3 kg	
7	1 pc	Installation and Operating Manual
8	1 pc	Operator unit
9	1 pc	Control unit with transformer
10	1 pc	Installation bag*

* No. 10 installation bags

1 pc	Pinion
1 pc	Plastic shield
1 pc	Circlip
2 pcs	Screw (3.8 mm torx)
6 pcs	Covers
2 pcs	Solenoid for limit switch
9 pcs	Slot nut
4 pcs	Pan head screw with hexagon socket
1 pc	Lever lock
1 pc	Locking clamp for lever lock
2 pcs	Key
1 pc	Dust cap
4 pcs	Torx screw with fillister head (M6 x 20 mm)
4 pcs	Hexagon screw (M6 x 16 mm)
1 pc	Tooth lwasher
1 pc	Hexagon socket screw (M6 x 10 mm)
1 pc	Earth clamp

Installation preparations

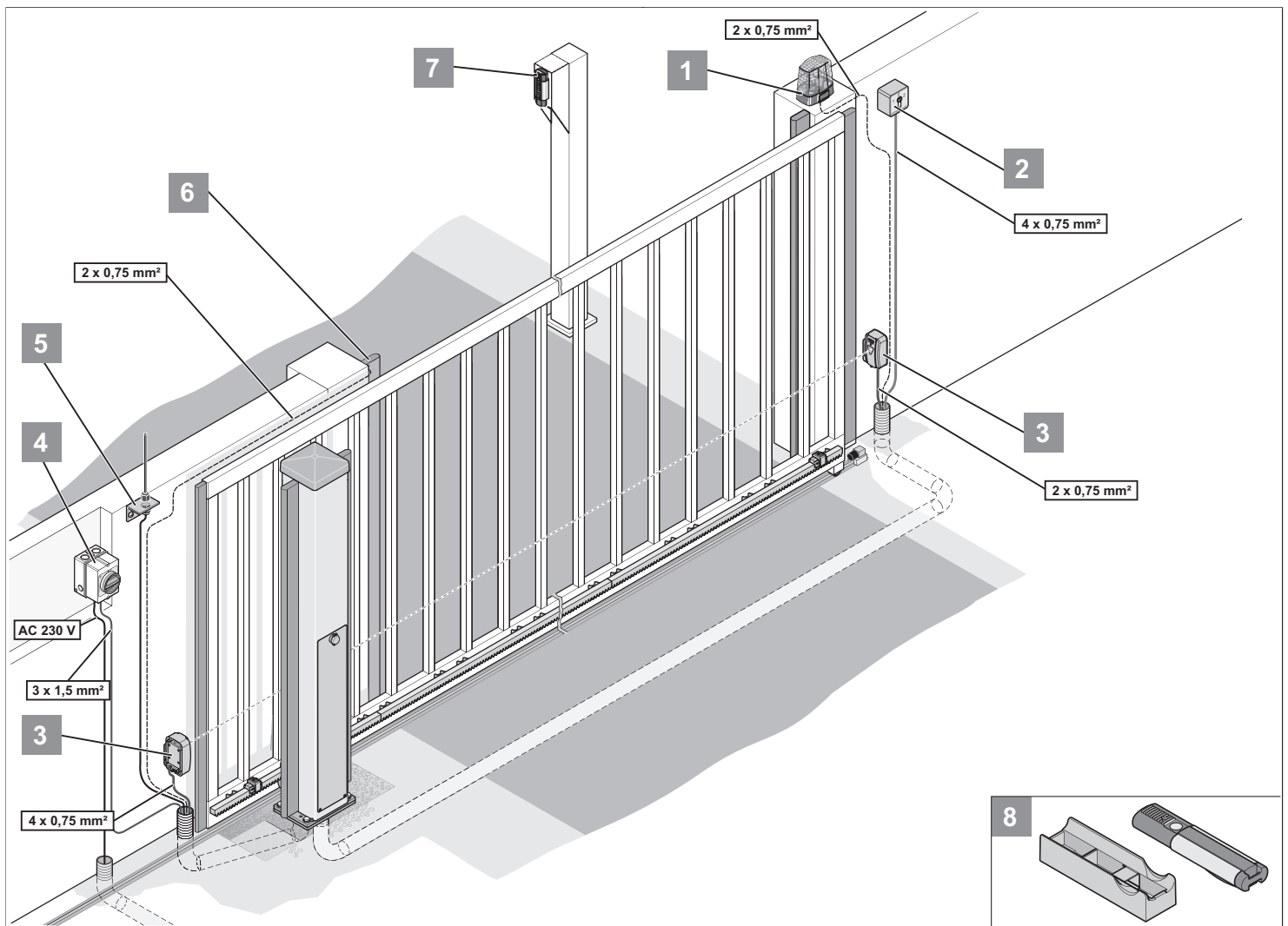

Tips for installation

- A safety device must always be connected as an NC contact so that safety is always guaranteed in case tripping or a defect.
- Determine the position of the accessories before installation together with the operator.

1	Warning light DC 24 V, 25 W, max 0.8 A
2	Key switch (1 or 2 contact)
3	Photo eye (prescribed for automatic closing, see EN 12543)
4	Main switch (lockable)
5	Rod antenna (including 10 m cable)
6	Safety contact strip (8.2 kOhm, optoelectronic safety contact strip)
7	Telecody unit
8	Car/wall holder for handheld transmitter

General preparations

- Remove or disable all locking devices (electric lock, bars, etc.) before installing the operator
- The gate must have a stable structure and must be suitable
- The gate must not show excessive lateral deviation throughout its range of movement
- The system wheels and bottom track and the roller and top guide must operate without excessive friction
- End stops must be installed at the "gate OPEN + gate CLOSED" positions to prevent derailing of the gate
- Install empty ducts under the gate for the cables of the mains supply line and the accessories (photo eye, warning light, key switch, etc.)



IMPORTANT INFORMATION!

Additional pulse transmitters are: hand-held transmitters, Telecody, wireless indoor switches and key switches. etc. In the case of the hand-held transmitter, Telecody or the wireless indoor switches a connecting line to the operator is not required (contact your dealer).

Installation

Foundation

- The foundation must extend below the frost line (approx. 800 mm in Germany).
- The foundation must be cured and horizontal.

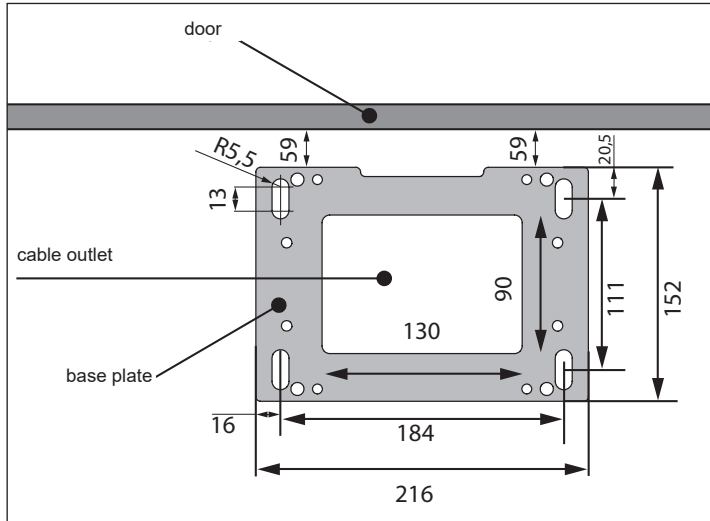

- Provide a hole in the foundation for the cables (cable outlet)

Installation of column

- ATTENTION! RISK OF INJURY WHEN DRILLING!**
- Wear safety glasses and close-fitting clothing
 - Bind long hair back

- ATTENTION!**
- Use only suitable and approved installation materials.

- IMPORTANT INFORMATION!**
- Dispose of packaging according to local regulations.

Step 1: Install cover for height adjustment

Required parts:

- 1x post
- 1x cover for height adjustment

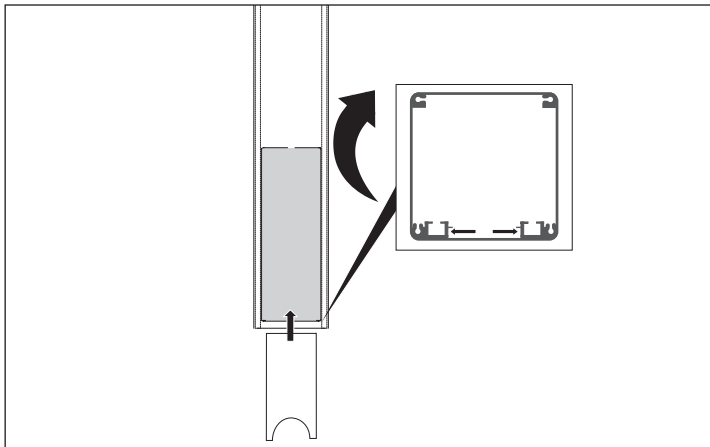

1. Carefully place column horizontally on a soft surface.
⇒ Bottom is accessible.
2. Insert cover into the inside back of the column as shown in the drawing.

Step 2: Installing the control unit

Required parts:

- 1x post
- 1x control unit
- 4x socket head bolts (installation bag)
- 4x slot nuts (installation bag)

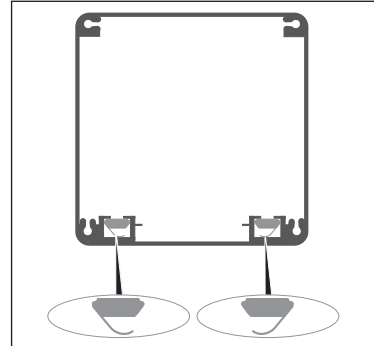

1. Insert slot nuts in C-profile on the inside back.
⇒ Note the installation direction of the slot nuts (diagram).

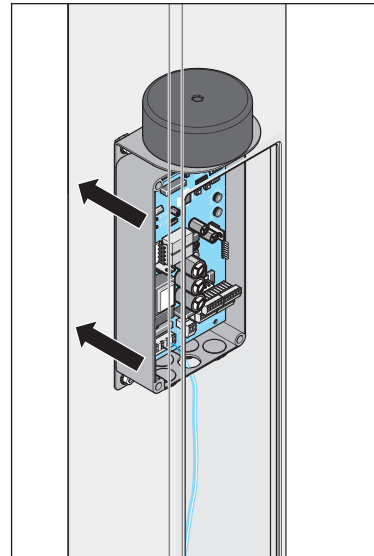

2. Insert control unit through the revision opening onto the C-profile.
3. Align control unit and slot nuts with the holes in the retainer plate exactly above the slot nuts.
4. Lightly screw in the socket head bolts and move the control unit to its subsequent position.
5. Tighten bolts.

Installation

Step 3: Installing the operator unit

Required parts:

- 1x post
- 1x operator unit
- 4x slot nuts (installation bag)
- 4x hexagon bolts (M6 x 16 mm)

1. Insert slot nuts into the C-profile as in step 2 (installing control unit).

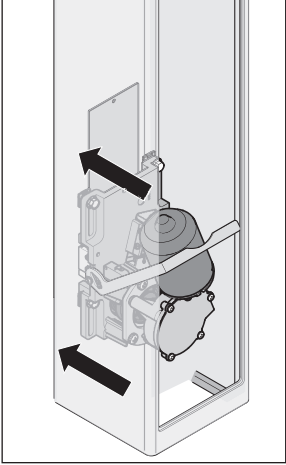

2. Install the operator unit in the same way as the control unit.

Step 4: Installing the base plate

Required parts:

- 1x post
- 1x base plate
- 4x torx screws with fillister head (M6 x 20 mm)

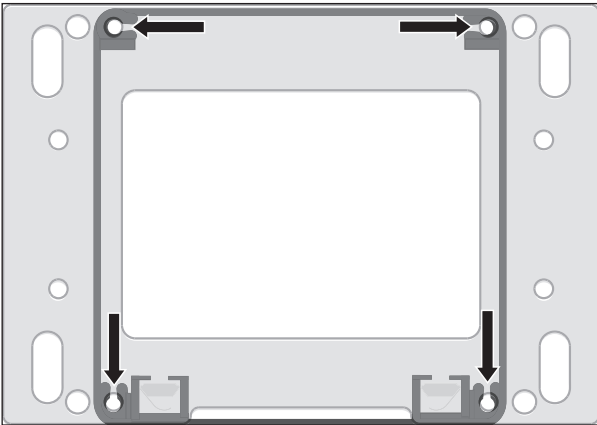

• Screw base plate to column from below as shown in the diagram.

⇒ Position the base plate with the milled groove in the direction of the gate.

– Only in the position can the screw heads be countersunk in the holes in the base plate.

Step 5: Installing the pinion

Required parts:

- 1x post
- 1x shield (installation bag)
- 1x pinion (installation bag)
- 1x circlip (installation bag)
- 2x screws (3.8 mm torx)

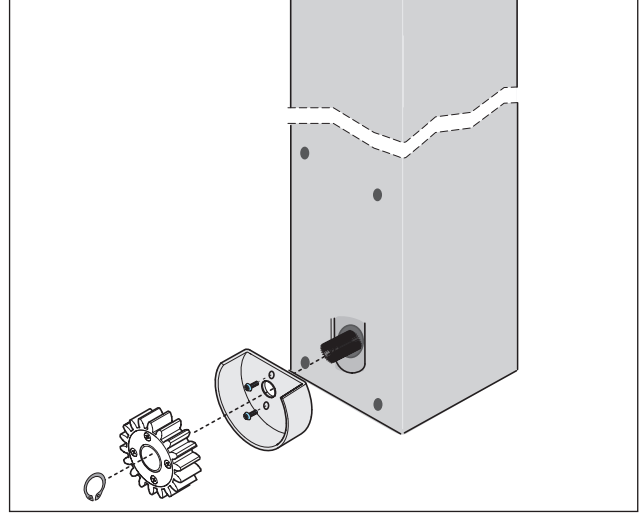

1. Position shield as shown in the diagram and screw in place.

2. Place pinion on motor shaft as shown in the diagram.

3. Lock pinion with circlip.

⇒ Use a suitable circlip pliers.

Step 6: Installing the revision flap

Required parts:

- 1x revision flap
- 1x lever lock (installation bag)
- 1x dust cap (installation bag)
- 1x locking clamp for lever lock (installation bag)
- 1x key (installation bag)

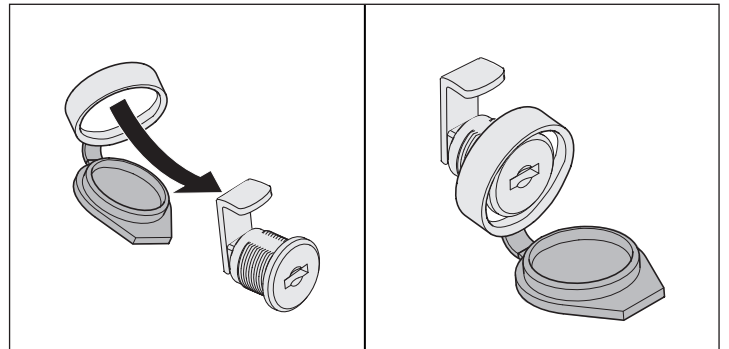

1. Assemble dust cap and lever lock as shown in the diagram.

Installation

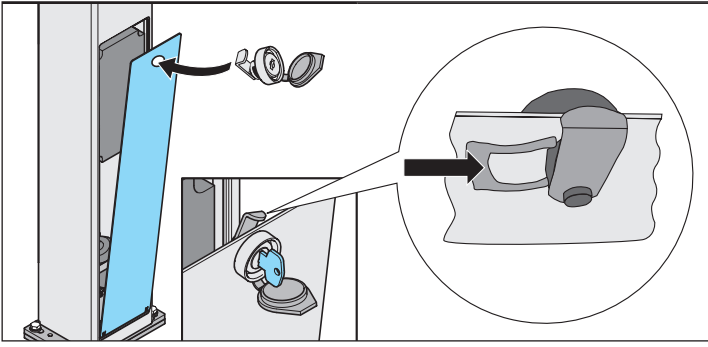

2. Connect revision flap and lock as shown in the diagram.
3. Attach lock to back of revision flap with locking clamp.
 - ⇒ Do not close revision flap yet, because additional work inside the column is required.

Installing the operator

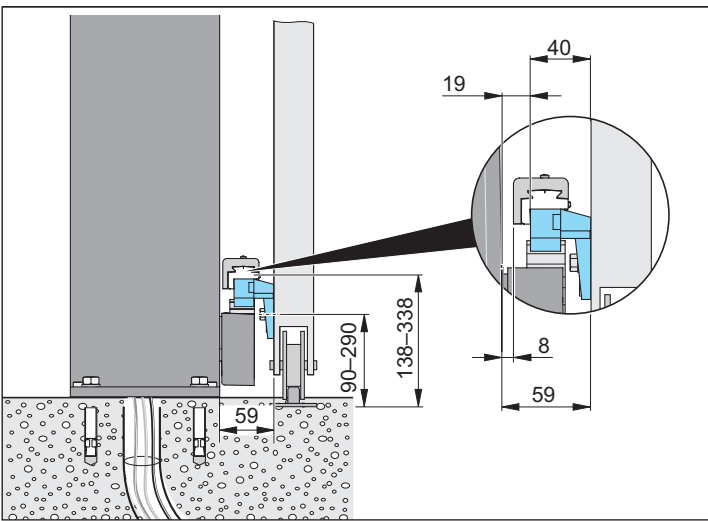

1. Place the operator on the foundation.
2. Position the operator as shown by the dimension in the diagram.
3. Mark the fixing points.
4. Define the subsequent position of the racks.
 - A second person holds a rack in the required position.

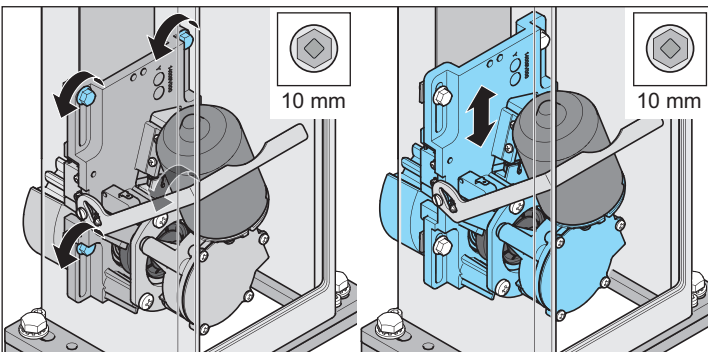

5. Unscrew the 4 external hexagon bolts (M6).
6. Push the motor unit upwards until the pinion is in contact with the rack.
7. Tighten the 4 external hexagon bolts at that position.

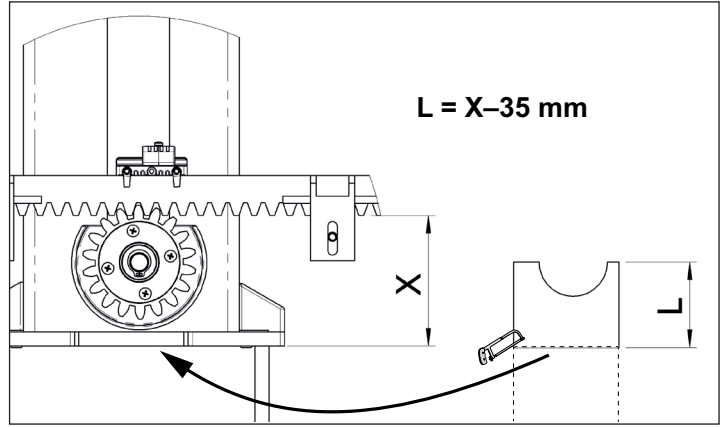

8. Measure the clearance.
 - Measure the distance between the floor (foundation) and rack.
 - ⇒ (The rack used for measurement can be placed aside for now)
 - Subtract 35 mm from the result.
 - Cut the cover plate included with the system to the calculated dimension.
9. Remove the operator from the foundation and place horizontally on a soft surface with the bottom accessible.
10. Insert the cover plate into the C-profile from below to close the opening under the pinion.
11. Drill holes in the foundation for the fastening points.
12. Replace operator on the foundation.

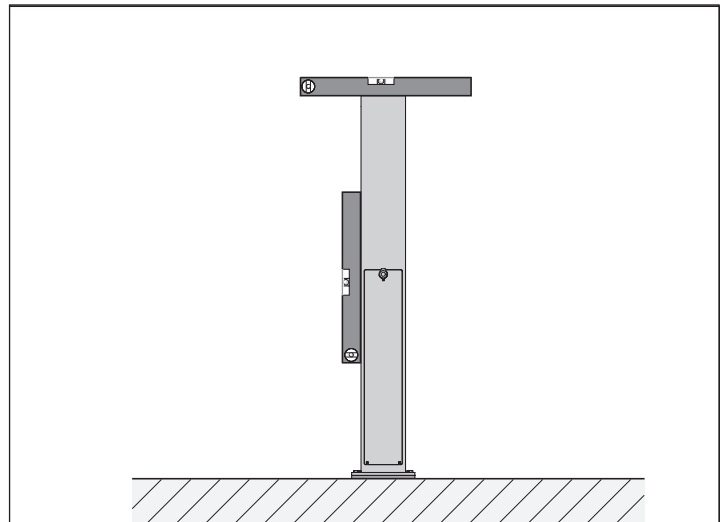

- Align column with spirit level



IMPORTANT INFORMATION!

If the unevenness of the base makes it impossible to align it correctly, a levelling plate, available as an accessory, will be required.

13. Screw operator to foundation.

Installation

i **IMPORTANT INFORMATION!**
Post cover must be secured to prevent removal.

i **IMPORTANT INFORMATION!**
Post cover is cast aluminium.

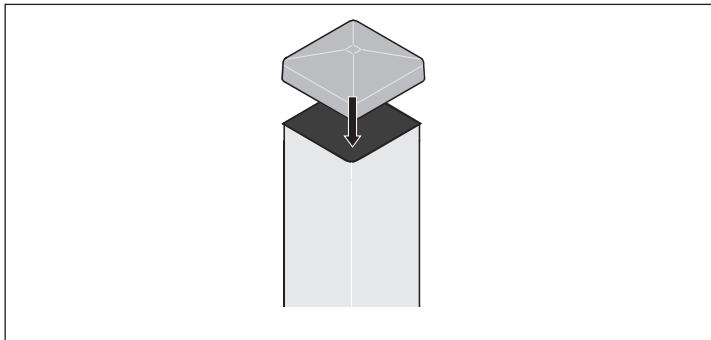

- Fasten post cover to post so it cannot be removed simply by lifting it.

Releasing the operator

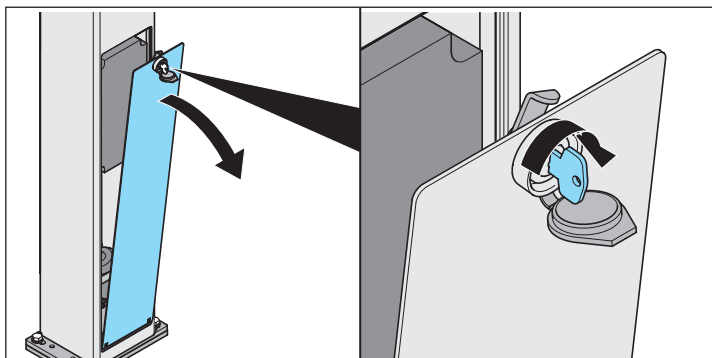

1. Open dust cap.
2. Unlock lock.
3. Open revision flap.

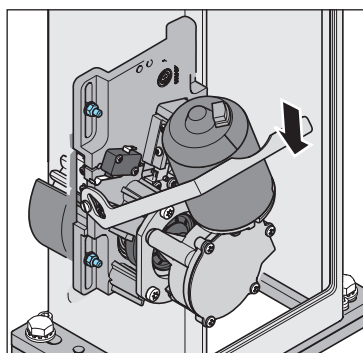

4. Push lever down.
⇒ Operator is unlocked.

Installing the racks

! **ATTENTION!**
Steel racks must have a minimum width of 12 mm.
Narrower steel racks may damage the drive.

- The rack must not press on the pinion at any position during operation, otherwise the gears will be damaged.
- Always start installing the rack on the passage side of the gate.
- The holes must always be marked near the pinion.

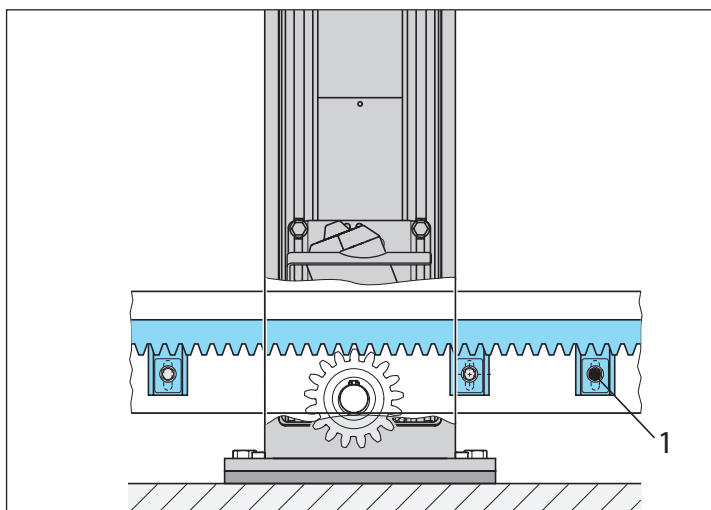
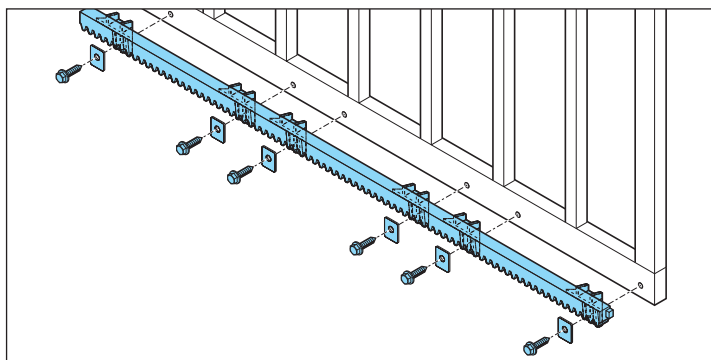

1. Before marking the first hole open the gate completely by hand.
2. Position the rack on the pinion and align it horizontally with a spirit level.
3. Mark the first hole, drill it and fasten.

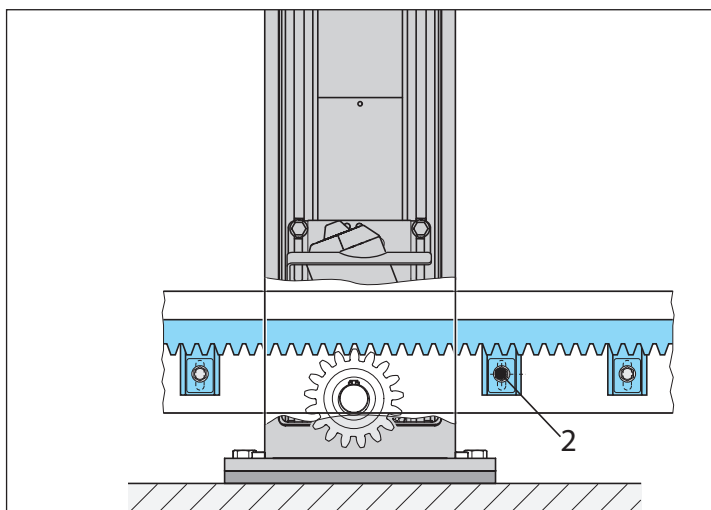

4. Slide gate towards the Closed position until the next drill point is positioned as shown in the diagram and mark the hole again.
5. Repeat until all drill positions are marked.
6. Fasten rack.

Installation

Installing additional racks



TIP!

Mark and drill the two outer holes first. Screw rack temporarily and mark the remaining holes. Then remove the rack again and drill the remaining holes. Then the rack can be finally bolted in position.

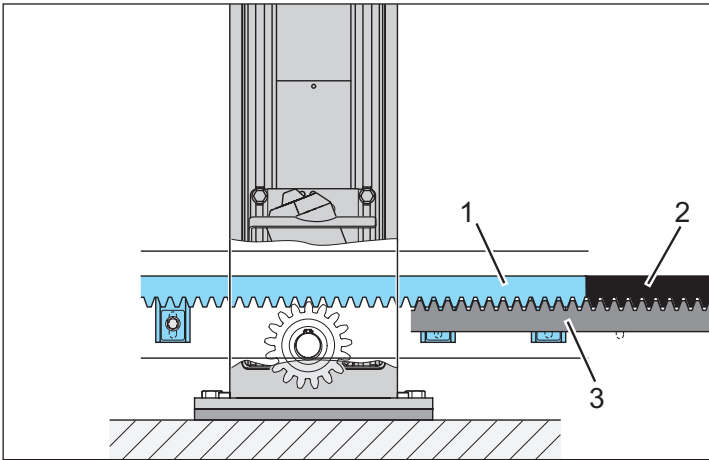

1. Position second rack (2) flush with the first rack (1) and hold another rack (3) against them from below so the teeth of the additional rack (3) mesh with the teeth of the two top racks (1 and 2). This will ensure that the second rack (2) is accurately fitted.
 - A height offset must be avoided at all times.
2. Mark and drill the holes for the second rack.
3. Attach the rack.
4. Repeat this procedure for additional racks.

Adjusting the tooth play



IMPORTANT!

Adjusting the tooth play compensates for minor unevenness and protects the gears.



IMPORTANT!

The weight of the gate must never rest on the motor shaft or pinion.

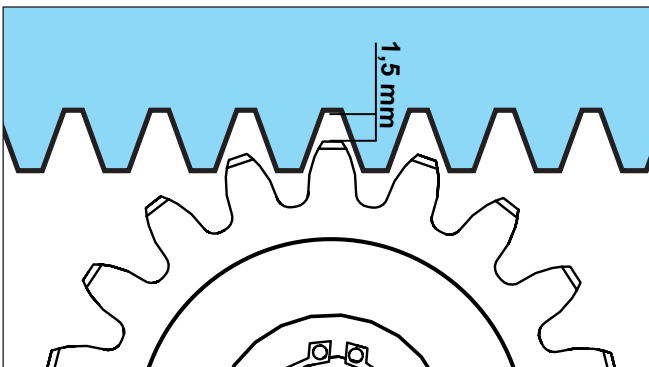

- The play between pinion and racks must be approx. 1.5 mm.

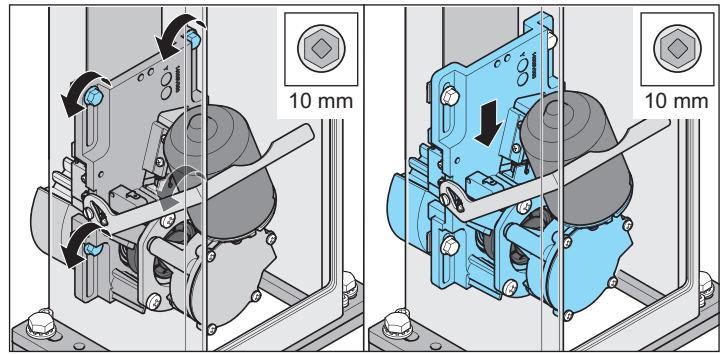

TIP!

Mark the position of the motor unit before loosening the bolts.

1. Unscrew the 4 hexagon bolts.
2. Adjust the height of the motor unit so the tooth play is approx. 1.5 mm.
3. Tighten the 4 hexagon bolts.

Installing clamps



IMPORTANT INFORMATION!

Clamps are also required for installing the high column (2,100 mm).

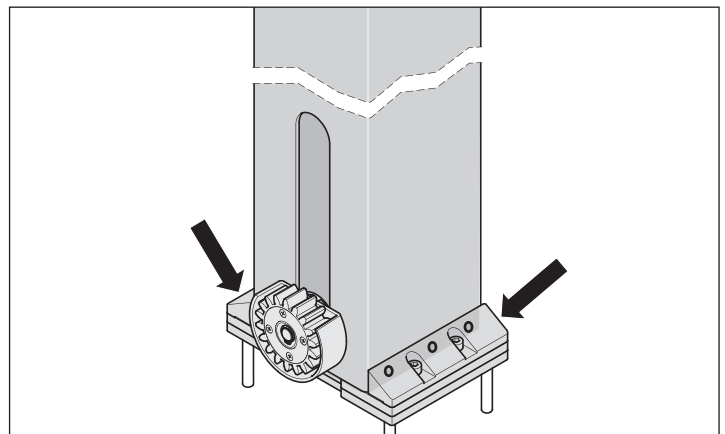

1. Fix clamps at the specified position.
 - ⇒ The column has holes.
 - ⇒ The clamps have locating pins.
2. Fasten the clamps with the 4 socket head bolts to max. 15 Nm each.

Connection

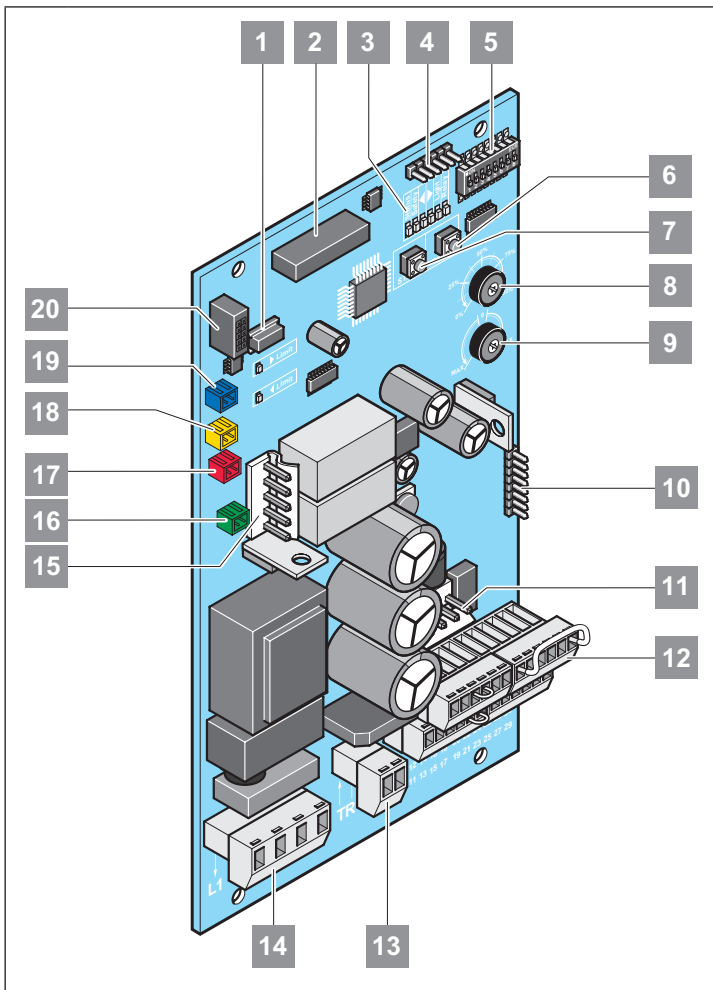

1. TorMinal connection
2. Slot for 4-channel radio receiver
3. LEDs
4. Software update interface
5. DIP switches
6. Prog. Button
7. Start button
8. Weight setting
9. Automatic close setting
10. SOM bus
11. Battery connection
12. Connecting strip for accessories
13. Secondary transformer
14. Mains connection
15. Motor connection
16. Motor lock (green)
17. Emergency release switch (red)
18. Limit switch left (yellow)
19. Limit switch right (blue)
20. Connection for wireless safety contact strip (accessory)

Safety instructions

- The control unit must be connected to the power supply by an electrician only
- Ensure that the operator is securely fastened to the ground and the racks on the gate to withstand the high forces generated when opening and closing the gate
- If a button is used for opening or closing, it must be installed within sight of the gate at a height of at least 1.6 m to prevent operation by children
- The rack must not press on the pinion during operation, otherwise the operator will be damaged. See "Adjusting the tooth play"
- Follow the standards for installation, e.g.: EN 12604, EN 12605.



IMPORTANT INFORMATION!

Set the DIP switch with a narrow and flat plastic object. Never use a metal object. This will damage the DIP switch.

Installation location



IMPORTANT INFORMATION!

As delivered the operator is installed on the left, i.e. the gate opens to the left.



IMPORTANT INFORMATION!

If a moving block with an internal rack is used, the DIP switch positions are reversed see "Adjustment of the limit switches" and "Moving block with internal rack".

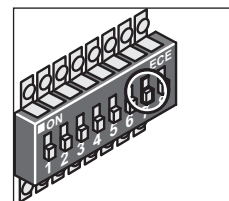
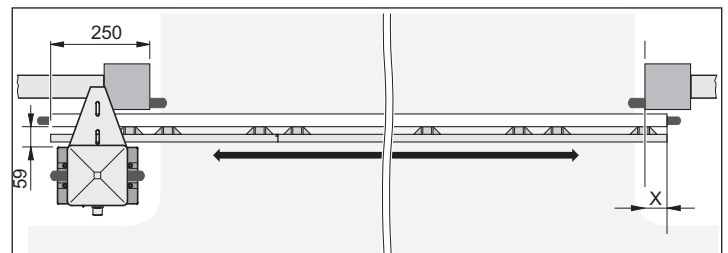

- DIP 7 OFF
⇒ Gate opens to the left.

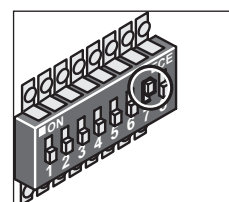
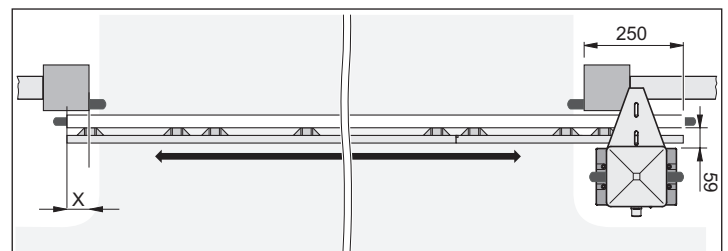

- DIP 7 ON
⇒ Gate opens to the right.

Connection

Mains connection



WARNING!

Risk of electric shock when working on live parts!
Always disconnect the complete system from the power supply before starting any electrical work.
Also unplug the battery pack.



IMPORTANT INFORMATION!

The mains power cable and the cables for the solenoids (limit switches) must be installed in the right of the column.

All signal wiring must be installed in the right of the column.



IMPORTANT INFORMATION!

Use only the ST-B-1 control unit with special programming for S 900/SP 900!



IMPORTANT INFORMATION!

In order to maintain the functionality of the technical equipment, we recommend that you observe the specified maximum lengths and minimum cross-sections for power cables!

Connection lines	Signal lines
Maximum length 20 m	Maximum length 25 m
Minimum cross-section 1.5 mm ²	

Approved wire cross sections for all terminals:
1 mm²–2.5 mm².

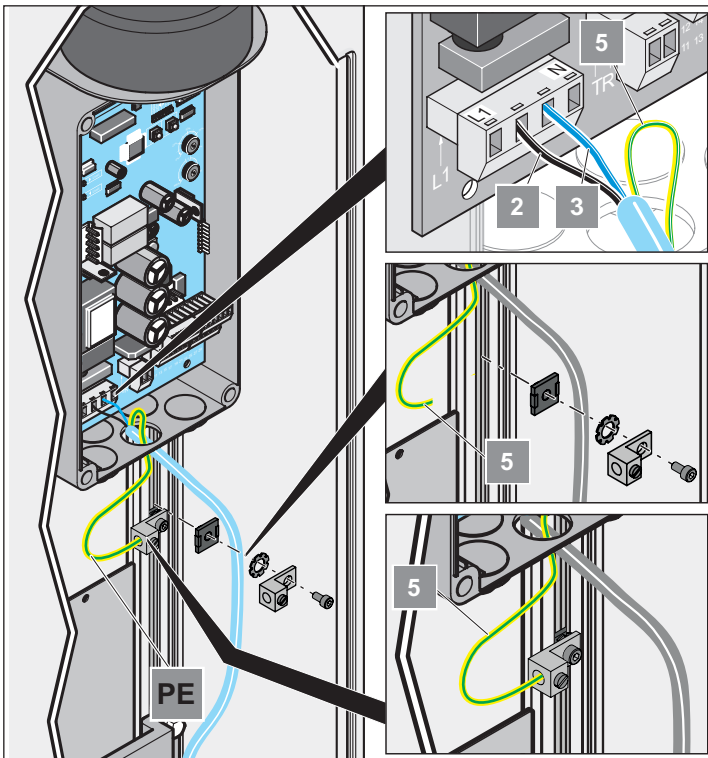

1	L1	Primary transformer line AC 220–240 V
2	L (black)	Mains supply line AC 220–240 V
3	N (blue)	Transformer line (neutral conductor)
4	N	Primary transformer line (neutral conductor)
5	PE (green/yellow)	The PE is run from the control unit housing and connected to the earth clamp under the control unit housing



ATTENTION!

Buttons and other command controls must be installed and actuated within view of the gate only.
Violation of this requirement may result in serious injury to third parties.



IMPORTANT INFORMATION!

Connect all safety components and accessories before commissioning, because the control unit automatically detects and saves the connected peripherals. If additional peripherals are connected later, the control unit will need to be reset first. Then the peripherals can be connected. When it is switched on for the first time after that, the control unit detects newly connected accessories and the system can be operated again.

Connecting safety devices



ATTENTION!

The system must be disconnected from the power supply before any work on the gate or operator.
Also unplug the battery pack.



ATTENTION!

The emergency stop button must be used for the specified purpose only.

Emergency stop button (normally closed contact)

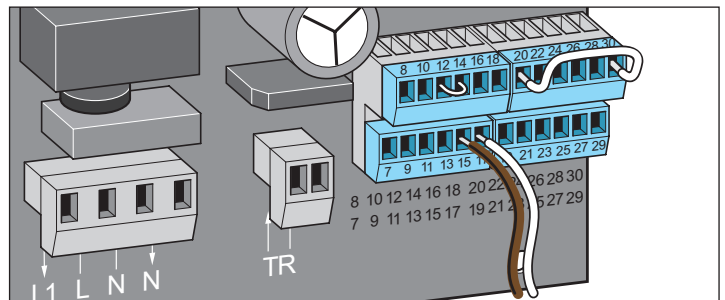

Terminals:

15 normally closed contact

17 normally closed contact

Safety contact strips

8.2 K Ω (OPEN)

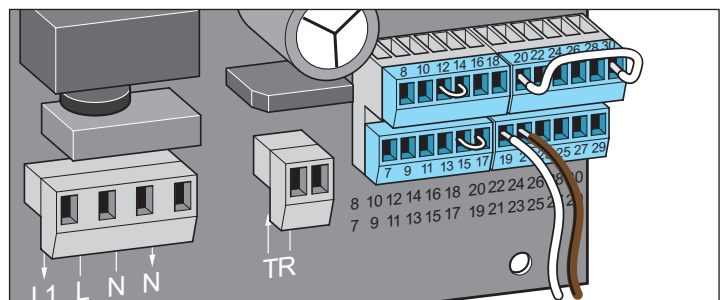

Terminals:

19 GND

21 Signal

Connection

8.2 K Ω (CLOSED)

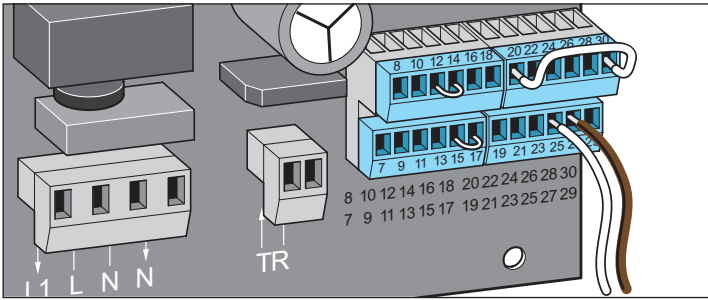

Terminals:
25 GND
27 Signal

Optoelectronic safety contact strip (OPEN)

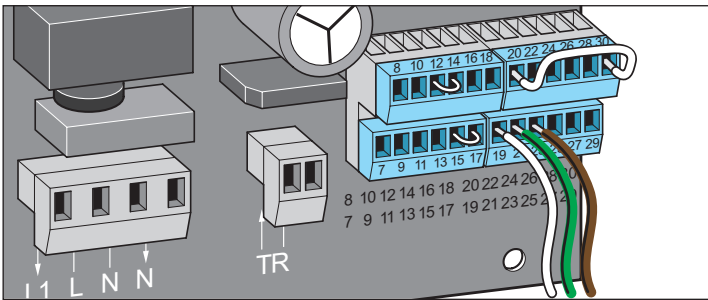

Terminals:
19 GND
21 Signal
23 +12 V

Optoelectronic safety contact strip (CLOSED)

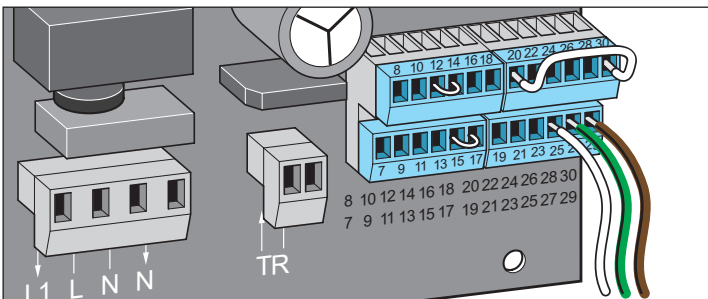

Terminals:
25 GND
27 Signal
29 +12 V

Photo eye

2-wire photo eye (bus system)

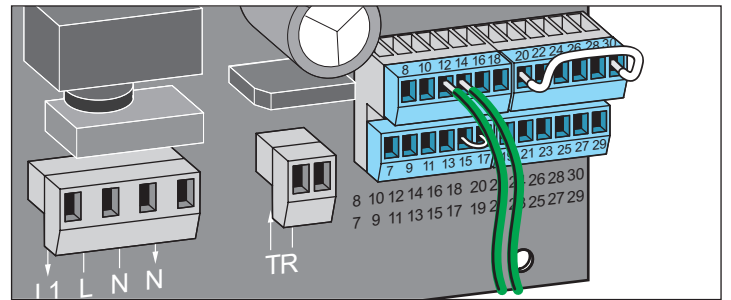

Terminals:
12 NC
14 COM



IMPORTANT INFORMATION!

The polarisation is irrelevant for connection!

4-wire photo eye



ATTENTION!

If an external device that is used only during movement operation is powered from the +20 V output (e.g. card reader), power-saving mode must be disabled. See "Power-saving mode".

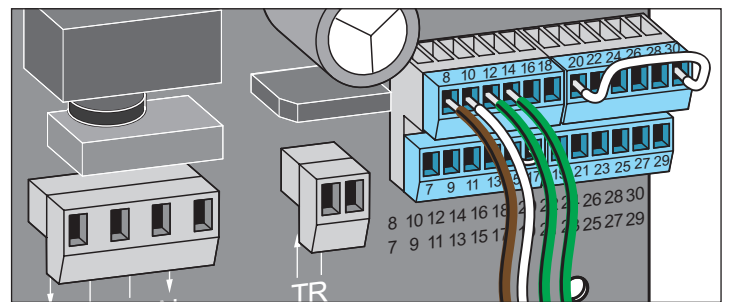

Terminals:
8 +20 V; max. 400 mA
10 0 V
12 NC
14 COM

Warning light

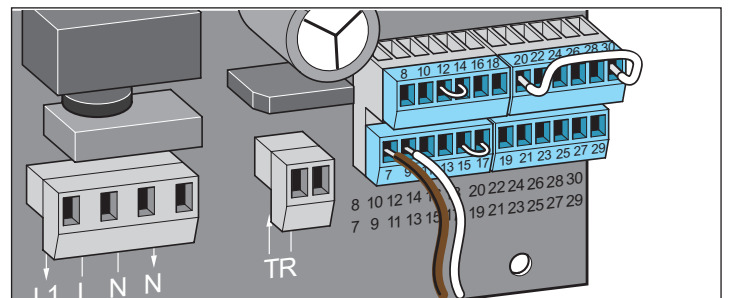

Terminals:
7 24 V (unregulated), max. 25 W
9 GND



IMPORTANT INFORMATION!

The control unit automatically generates the flashing warning light.

Connection

Connecting button



IMPORTANT INFORMATION!

Connect button only!

Do not use locking switches, because continuous signals cannot be processed.

Pulse button

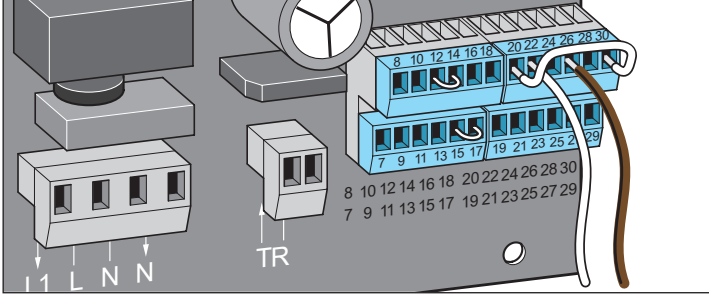

Terminals:

- 22 GND
- 26 Signal (normally open contact)

Defined opening and closing



ATTENTION!

Which button has which function must be clearly labelled.

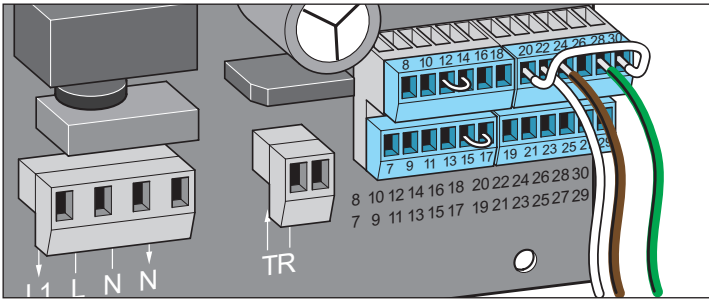

Terminals:

- 22 GND
- 24 OPEN input (normally open contact)
- 28 CLOSED input (normally open contact)

Partial opening/timer input



IMPORTANT INFORMATION!

Either a switch for the partial opening or a timer can be connected! A timer can be set up only using TorMinal. See the separate TorMinal instructions.

When the timer is connected, the partial opening can be used by radio again.

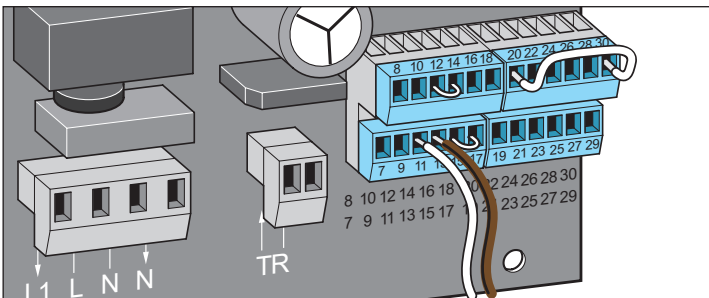

Terminals:

- 11 Partial opening (make contact)
- 13 GND

Stop button



IMPORTANT INFORMATION!

Remove jumper.

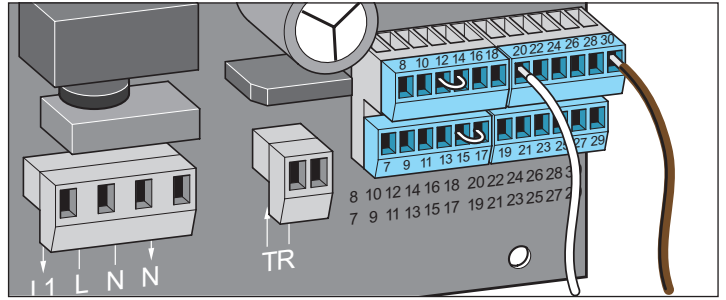

Terminals:

- 20 GND
- 30 STOP input (normally closed contact)

Open-Stop-Close button



ATTENTION!

Which button has which function must be clearly labelled.

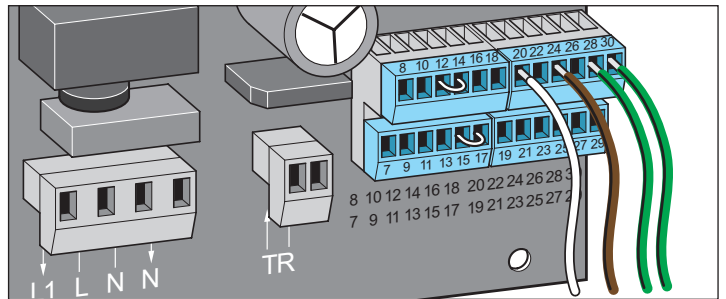

Terminals:

- 20 GND
- 24 OPEN input (normally open contact)
- 28 CLOSED input (normally open contact)
- 30 STOP input (normally closed contact)

Potential-free relay contact

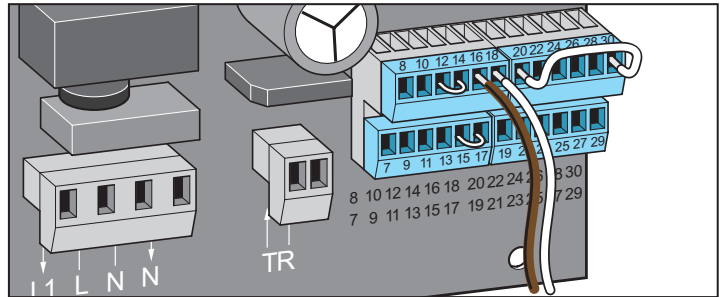

Terminals:

- 16 ; 18 max. 24 V (DC or AC); max. 1 A



IMPORTANT INFORMATION!

Factory setting: Pulse at motor start. Additional functions can be programmed with TorMinal.

See TorMinal instructions e.g.: Gate status indication, triggering of the external light etc.

Optional connections



ATTENTION!

The system must be disconnected from the power supply before any work on the gate or operator. Also unplug the battery pack.

Radio-based safety contact strip

Connect radio receiver to board



ATTENTION!

The system must be disconnected from the power supply before plugging in the radio receiver. Also unplug the battery pack.

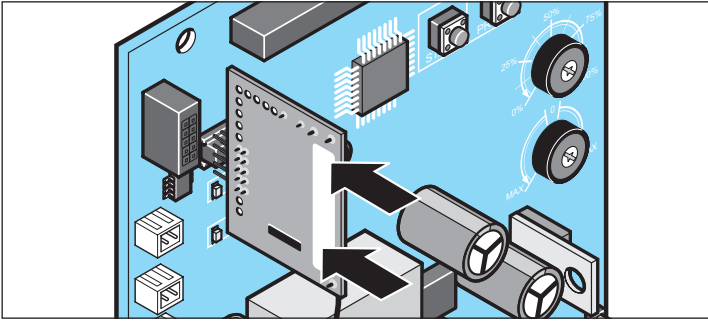

1. Connect the receiver board to the control unit as shown in the diagram.



IMPORTANT INFORMATION!

The maximum runtime for a gate movement when using a radio-based safety contact strip is reduced to 80 seconds for safety reasons.



IMPORTANT INFORMATION!

For information on connection, settings etc., see the separate instructions for the radio-based safety contact strip.

Connection/commissioning

Battery pack



ATTENTION!

Installation and inspection of the battery pack may only be performed by a qualified electrician.



ATTENTION!

The system must be disconnected from the power supply before working on the operator. Also unplug the battery pack.



ATTENTION!

The battery pack is not suitable for use on lifting gates.



ATTENTION!

Only a genuine battery pack from the company SOMMER Antriebs- und Funktechnik GmbH may be used!



IMPORTANT INFORMATION!

The general requirements for working with batteries (see instructions for battery pack) must be observed.

1. Disconnect the system from the power supply.

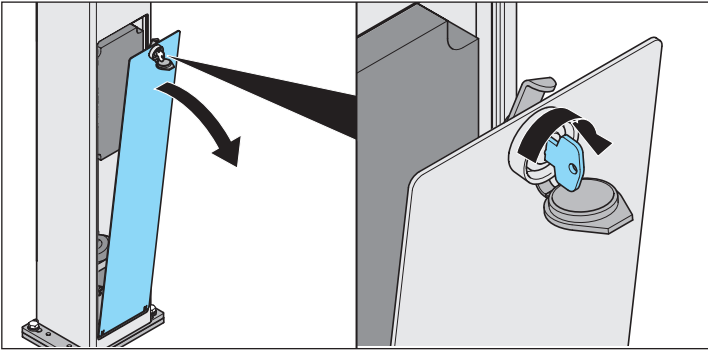

2. Open revision flap.

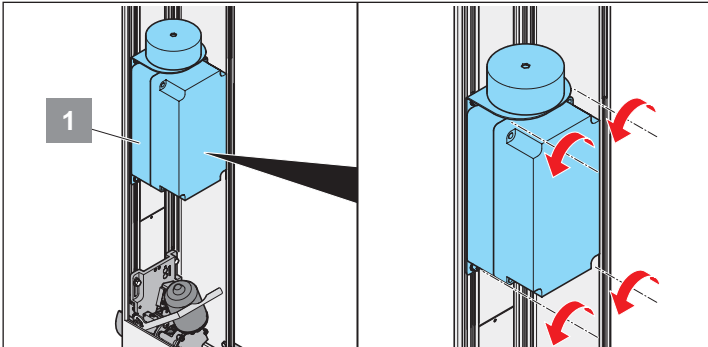

3. Unscrew the 4 screws on the control unit (1).

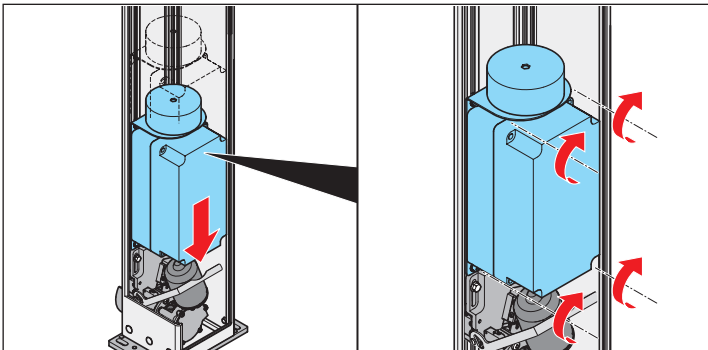

4. Lower the control unit approx. 150 mm and fix in place again.

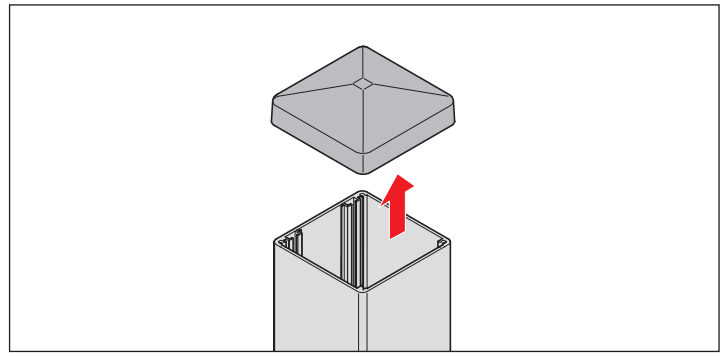

5. Remove the post cover.

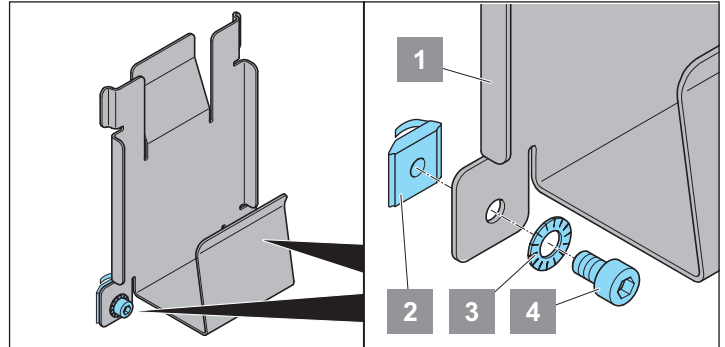

6. Prepare base plate (1) for installation.

⇒ Insert screws (4) through the washers (3) and the fastening holes.

⇒ Rotate slot nuts (2) from the opposite side to the screws (do not tighten yet).

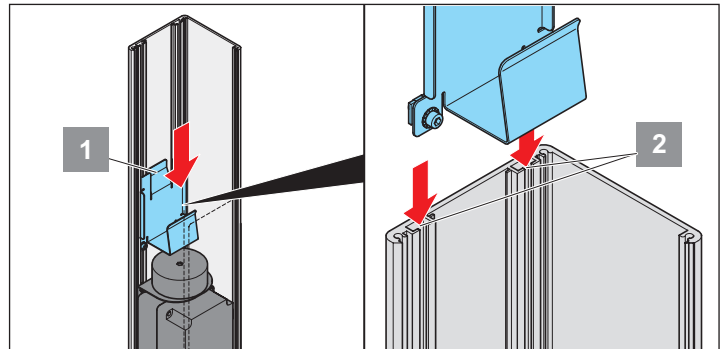

7. Insert installation plate (1) from above into the post profile (C-profile) (2) and push down.

⇒ The installation plate has been correctly inserted in the post if the guide nose (1) runs between the two C-profiles (2).

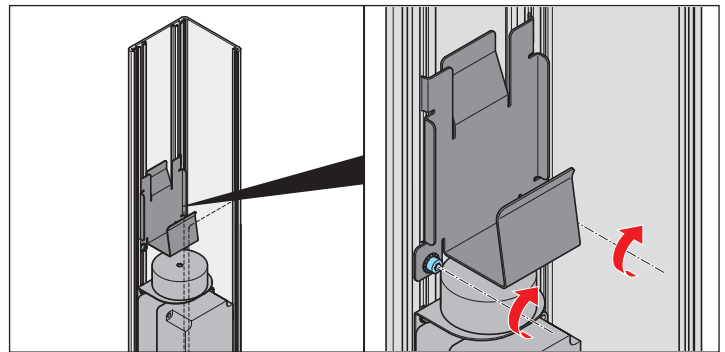

8. Position the installation plate and tighten the screws.

⇒ The installation plate is correctly positioned if it is immediately under the control unit transformer (see diagram).

Connection/commissioning

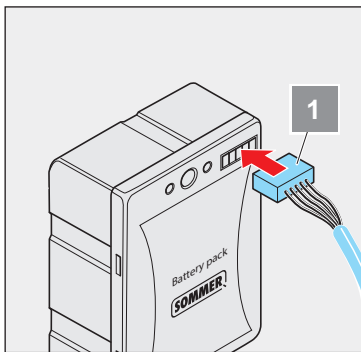

9. Plug connector cable into the battery pack (1).

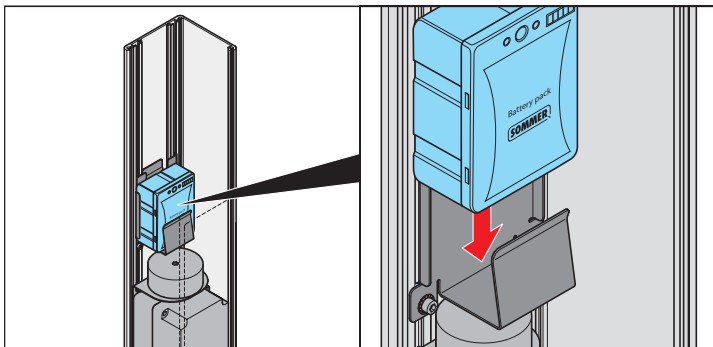

10. Place battery pack on the installation plate.

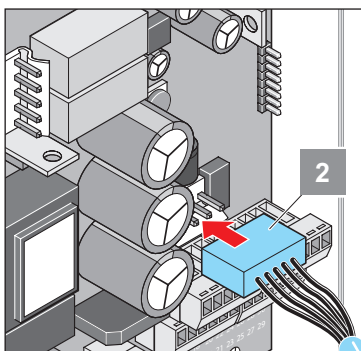

11. Remove control unit cover and plug the other end of the connector cable into the control unit (2).

⇒ For better accessibility disconnect the terminal block with terminals 9–18 and reconnect after connecting the connecting cable.

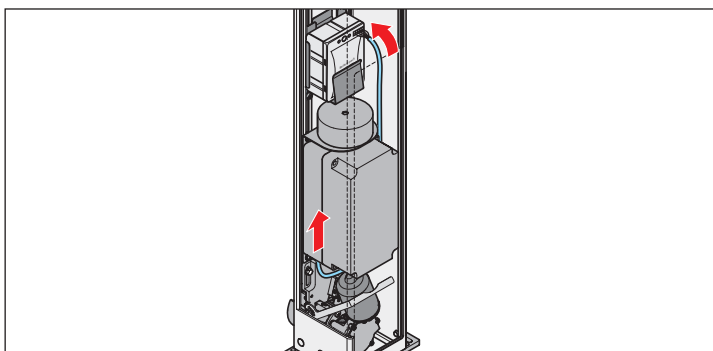

12. Replace the cover.

⇒ Make sure that the connector cable is positioned as shown in the diagram.

⇒ If necessary, push the control unit up slightly.

13. Connect mains power.

Test run

1. Run a complete cycle with mains power (gate OPEN and gate CLOSE).
2. Start a new cycle and disconnect the mains power during the cycle.
 - ⇒ Operator continues running (speed may change).
 - ⇒ Battery pack is detected and activated.
3. Restore mains power.

External antenna

- If reception is inadequate with the radio receiver internal antenna, an external antenna can be connected.
- The antenna cable may not exert any mechanical force on the radio receiver; provide for stress relief.
- Define the installation location together with the operator.

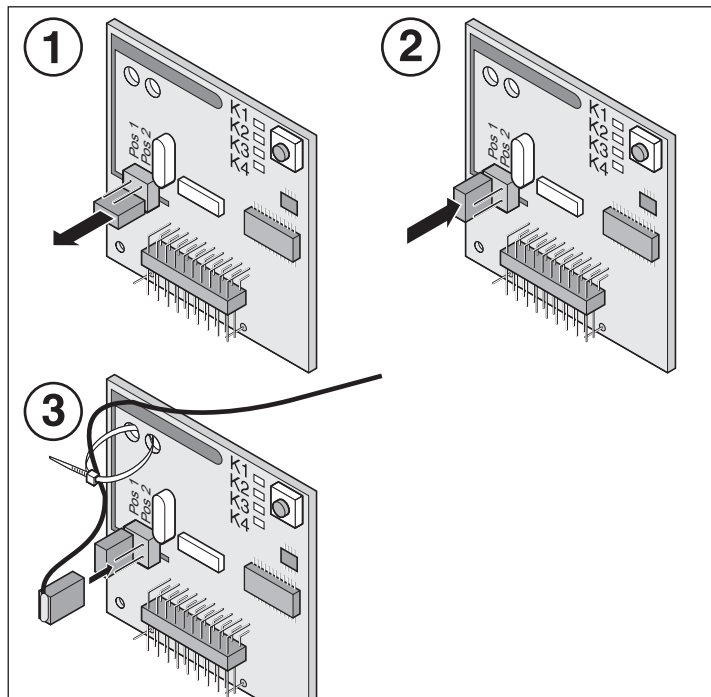
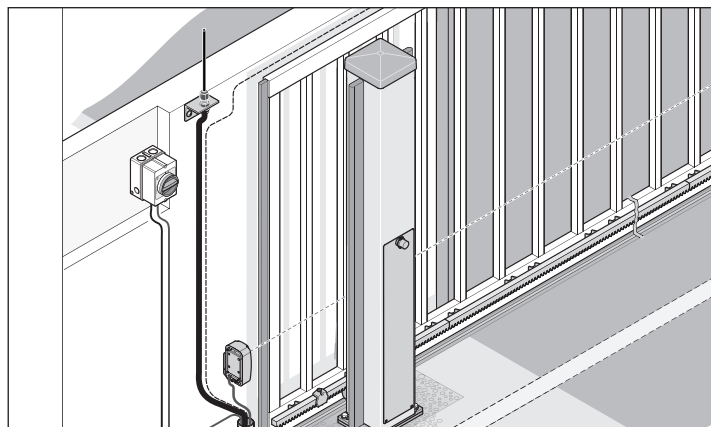

1. Pull jumper from pins.
2. Place jumper in "Pos 1".
3. Place external antenna jumper at "Pos 2".



IMPORTANT INFORMATION!

Follow the external antenna instructions.

Connection/commissioning

Safety instructions



IMPORTANT INFORMATION!

After installation of the operator, the person responsible for the installation must complete an EC declaration of conformity for the gate system in accordance with Machinery Directive 2006/42/EC and apply the CE mark and a type plate. This is also required for private installations and also if the operator is retrofitted to a manually operated gate. This documentation and the Installation and Operating Instructions are retained by the operator.



IMPORTANT INFORMATION!

The commissioning sequence described below is important. All safety components and accessories connected to the control unit are automatically detected by the control unit when it is switched on and its correct function is tested. If peripherals are connected later, the control unit must be reset before the operator can be operated again.

Adjusting gate weight



ATTENTION!

The gate weight must be precisely adjusted. If the setting is not correct, the operating forces will be too high and the power shut-off will be too late. Severe injuries may result.

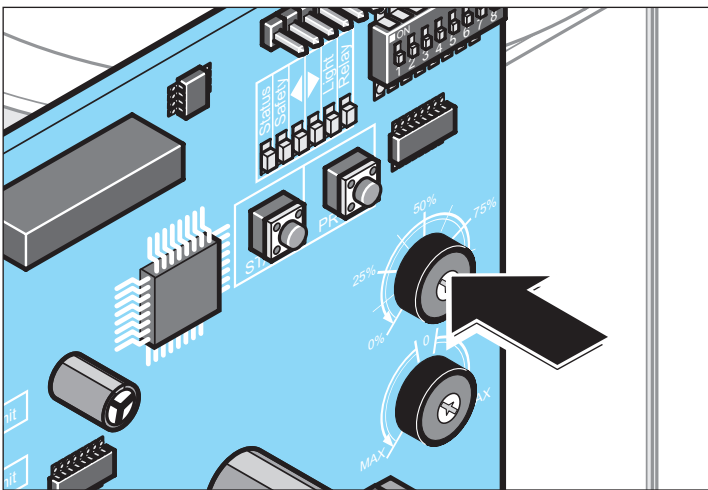

Gate weight	Setting
400 kg	100 %
300 kg	75 %
200 kg	50 %
100 kg	25 %

Locking weight potentiometer



IMPORTANT INFORMATION!

(1) After adjusting the gate weight, DIP switch 3 must be set to ON immediately. This prevents the weight adjustment and other parameters important for safe operation of the system from being accidentally changed.

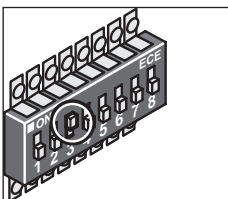

Connecting the power supply

Connect the power supply of your operator.

Switch on operator

Switch on the operator at the main switch.

Installing limit switches



ATTENTION!

The limit switches contain strong magnets!

Strong magnetic fields may interfere with some medical devices such as pacemakers!
Do not place magnets close to such devices!

In case of doubt, consult the manufacturer of the device.

Set left end position

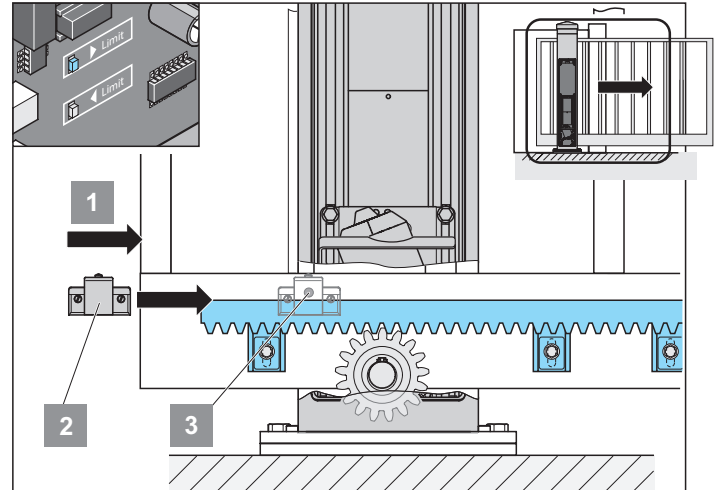

1. Make sure that the operator is unlocked.
2. Push gate to the left end position (1).
3. Slide the limit switch magnet (2) to sensor (3) until the latter switches (LED ◀ on the control unit lights up).
4. Tighten limit switch magnet 2.

Set right end position

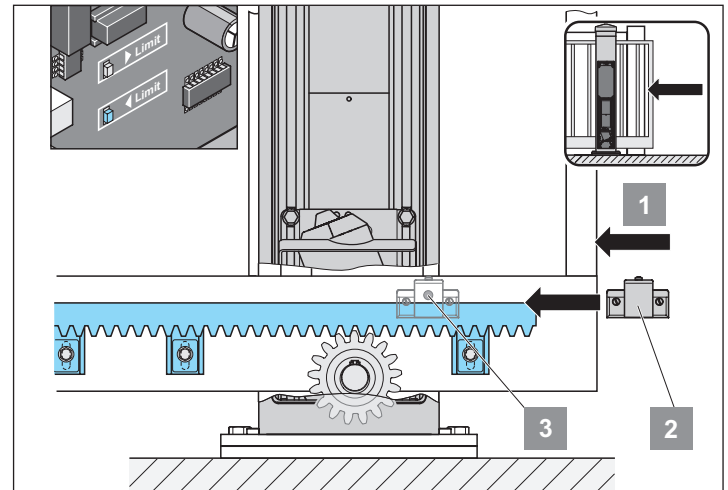

1. Push gate to the right end position (1).
2. Slide the limit switch magnet (2) to sensor (3) until the latter switches (LED ▶ on the control unit lights up).
3. Tighten limit switch magnet 2.

Connection/commissioning

i **IMPORTANT INFORMATION!**
Fine adjustment of the limit stops.

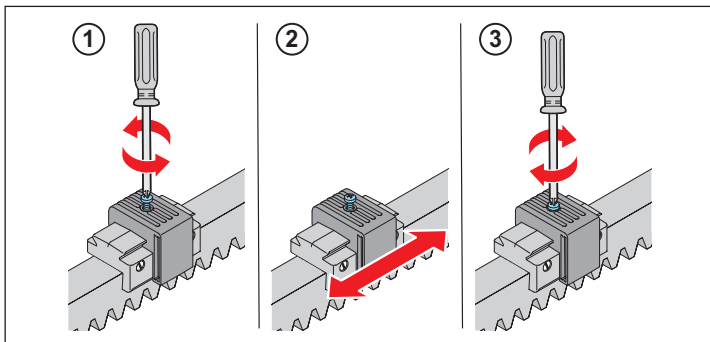

1. Loosen screw.
2. Adjust switching magnet.
3. Tighten screw.

Install limit switch and adjust end positions with a rectangular rack cover

i **IMPORTANT INFORMATION!**
The rack cover cannot be procured from SOMMER as an accessory!

i **IMPORTANT INFORMATION!**
If a rectangular cover is installed on the rack, the limit switches must be attached to the cover.

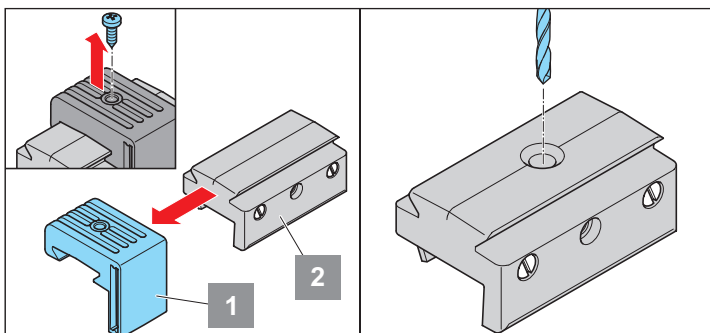

1. Unscrew screw on top section (1) of the solenoid holder.
2. Pull top section off to the side.
3. Drill a hole in the bottom section (2) of the solenoid holder for screwing it to the rack cover and smooth the hole thoroughly.

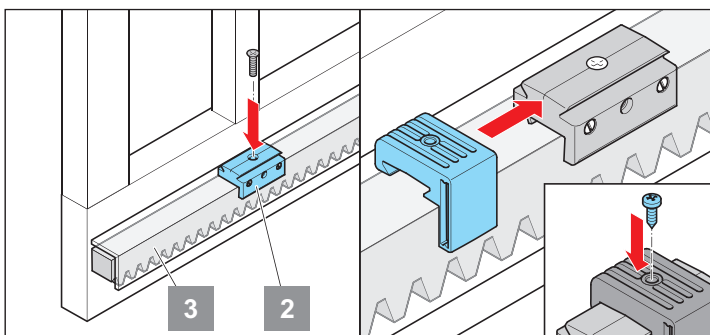

4. Screw the bottom section (2) of the solenoid holder to the rack cover at the required position (3).
5. Push the top section (1) of the solenoid cover onto the bottom section (2), perform the fine adjustment (see note on "fine adjustment of the limit stops") and screw it in position.

Adjust limit switch when using a moving block with internal rack

i **IMPORTANT INFORMATION!**
Not available from SOMMER as an accessory!

i **IMPORTANT INFORMATION!**
Because another pinion acts to transfer the movement of the motor to the rack when a block is used, the direction of motion of the gate is reversed. This means that the limit switches on the board must be reversed.

Optional: Operation of a moving block with internal rack

! **ATTENTION!**
DIP switch position of DIP switch 7 is reversed here! (see "Installation location")
After installation immediately test all safety devices (e.g. photo eye in CLOSED direction and safety contact strips in both directions) to ensure that they are operating correctly!

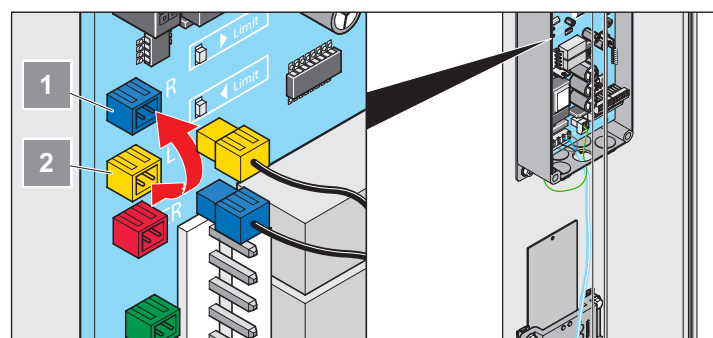
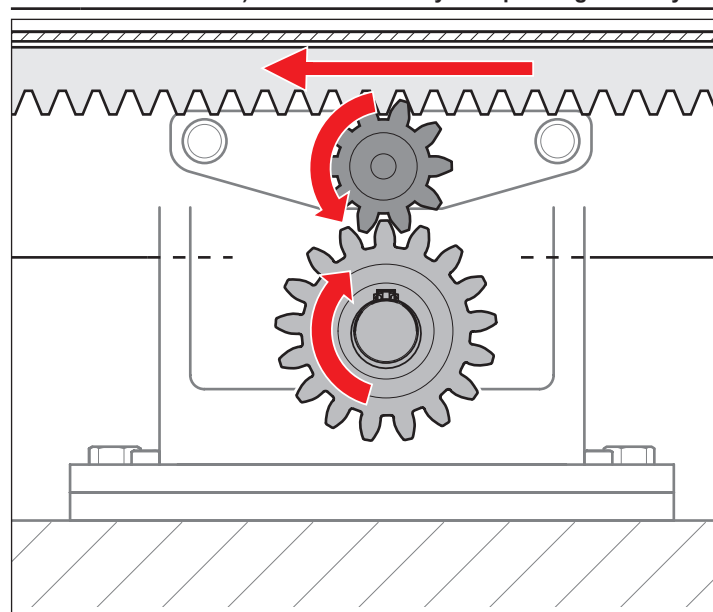

1. Open control unit housing.
2. Pull off the two blue and yellow limit stop wires.
3. Connect the limit stop wire with the yellow plug to the blue socket (1).
4. Connect the limit stop wire with the blue plug to the yellow socket (2).

Commissioning/operation

Locking operator

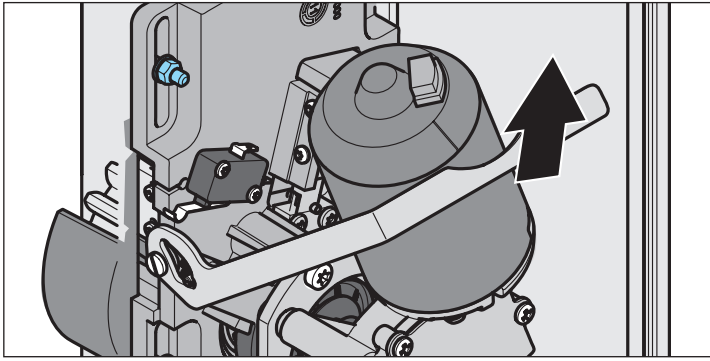

1. Push locking lever upwards.
⇒ Operator is locked. The gate can only be moved by motor.
2. Switch on main switch.
⇒ LED (Status) on.

Rest control unit

⇒ Power must be connected.

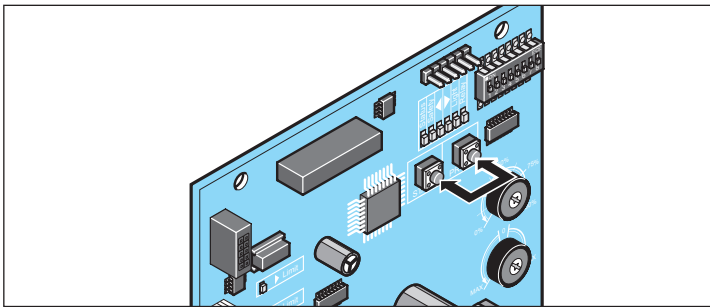

1. Press and hold "Start" and "Prog" simultaneously
⇒ Light LED starts flashing.
2. Release buttons when light LED remains steady.
⇒ Reset completed successfully.

Programming



IMPORTANT INFORMATION!

Once programming has been started, it cannot be interrupted and restarted at a later time. If programming is interrupted, it must be restarted from the beginning.

The "Light" LED flashes continuously during programming runs (as a rule 3 complete runs from one limit position to the other). The light LED remains steady if the gate remains stationary between cycles.

On completion of programming the LED switches off.

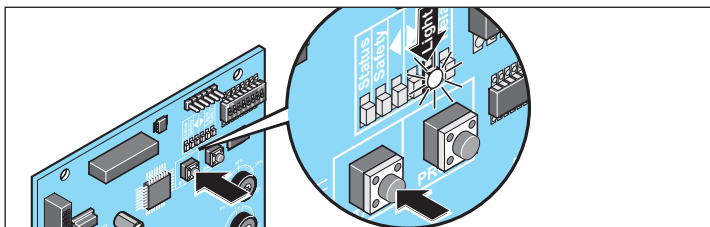

1. Move gate manually to centre position.
2. Briefly press the start button on the control unit or control device.



IMPORTANT INFORMATION!

If a lifting magnet was fitted at the factory or retrofitted, it is immediately activated and the learning run starts in the normal way.

If no lifting magnet was installed at the factory, the operator first moves 3x each towards the left and right before the learning run begins.

- ⇒ Movement to initial position in automatic mode at reduced speed to "Gate OPEN" end position.
3. Briefly press the start button on the control unit or control device again.
⇒ First programming run for path measurement in automatic mode at reduced speed to "Gate CLOSED" end position.
 4. Briefly press the start button on the control unit or control device again.
⇒ Second programming run for force measurement in automatic mode at standard speed including soft ramps to "Gate OPEN" end position.
 5. Briefly press the start button on the control unit or control device again.
⇒ Third programming run for force measurement in automatic mode at standard speed including soft ramps to "Gate OPEN" end position.
 - When the "Light" LED goes out,
⇒ programming is complete.
 - If the light LED remains on,
⇒ repeat the procedure until the LED is out.



IMPORTANT INFORMATION!

If a programming movement is interrupted by an obstacle (operator stops and reverses), the programming procedure must be continued in dead man mode.

Press and hold the start button on the control unit or control device until the programming runs described above are finished. Do not briefly press and release the button as in automatic mode.

Checking the force tolerance



ATTENTION!

Rubber safety strips must be used on the main and auxiliary closing edges. No sliding gate without safety strips may be used!

- ⇒ Our program contains various safety strips, both active (triggers an immediate stop of the gate at contact) and passive (takes up part of the inertial mass of the moving gate).

See also the section "Maintenance and care/Regular testing" on the subject of safety strips.

Test run

1. Close the gate.
2. Press button (1) once.
Gate opens to gate OPEN limit position.
3. Press button (1) once.
The gate closes until the gate CLOSED end position is reached.
4. If one of the programmed gate end positions is not reached (gate OPEN or CLOSED), check that the correct gate weight is set on the potentiometer.
⇒ Correct if necessary.

Commissioning/operation

Safety instructions

- The local safety regulations for the system must be complied with to ensure safe operation. Information is available from electrical utility companies, VDE (Association for Electrical, Electronic & Information Technologies) and professional associations.
- The operator is not protected against interference caused by other telecommunications equipment or devices (e.g. wireless systems which are being operated properly in the same frequency range).
- Replace the handheld transmitter unit's batteries if you experience reception problems.

Radio receiver (version Somloq Rollingcode)

- ATTENTION!**
- The radio receiver must be connected or disconnected from the control unit only if the control unit is disconnected from the power supply. If the operator is operated by battery, it must also be disconnected from the control unit.

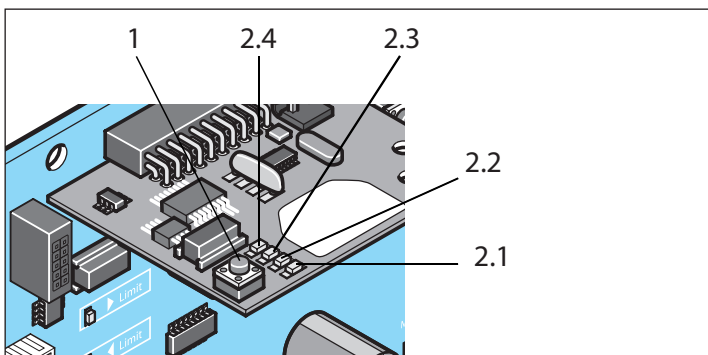

1. Learn button
- 2.1 LED channel 1
- 2.2 LED channel 2
- 2.3 LED channel 3
- 2.4 LED channel 4

Explanation of radio channels

Channel 1	Pulse mode
Channel 2	Partial opening
Channel 3	Defined OPEN
Channel 4	Defined CLOSE or pot.-free relay (must be activated by TorMinal)

Pulse sequence of gate movements

Radio channel 1: OPEN – STOP – CLOSE – STOP – OPEN – STOP – CLOSE...

Radio channel 2: Partial opening

Radio channel 3: OPEN – STOP – OPEN – STOP – OPEN...

Radio channel 4: CLOSE – STOP – CLOSE – STOP – CLOSE...

Deleting the radio receiver memory

1. Press and hold the teach-in button (1).
 - ⇒ After 5–seconds an LED flashes – after another 10–seconds an LED is steady.
 - ⇒ After a total of 25 seconds all LEDs light.
2. Release the teach-in button (1).
 - ⇒ The deletion procedure is ended.

Deleting a channel from the radio receiver

1. Press and hold the teach-in button (1).
 - 1x for channel 1; the LED (2.1) lights.

- 2x for channel 2; the LED (2.2) lights.
 - 3x for channel 3; the LED (2.3) lights.
 - 4x for channel 4; the LED (2.4) lights.
 - ⇒ The LED flashes after 5 seconds.
 - ⇒ The LED lights after another 10 seconds.
2. Release the teach-in button (1).
 - ⇒ The deletion procedure is ended.

Programming the handheld remote control

- ATTENTION!**
- The radio remote control may only be used if the door's movement can be watched and no persons or objects are within the range of movement.

- IMPORTANT INFORMATION!**
- Delete the memory of the radio receiver before programming the handheld transmitter for the first time.

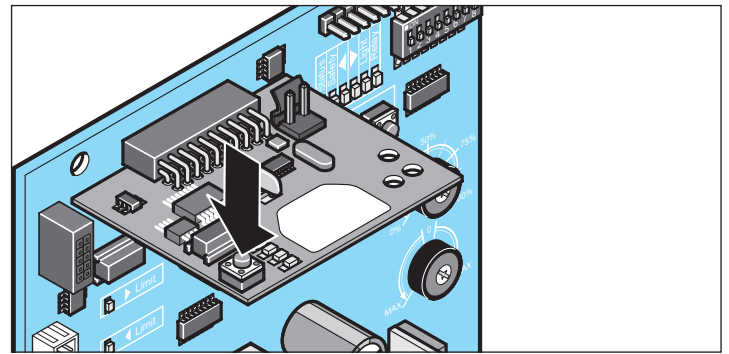

1. Press the teach-in button.
 - 1x for channel 1; the LED (2.1) lights.
 - 2x for channel 2; the LED (2.2) lights.
 - 3x for channel 3; the LED (2.3) lights.
 - 4x for channel 4; the LED (2.4) lights.
 - ⇒ If no code is sent within 10 seconds, the radio receiver switches to Normal mode.
2. Press the desired hand-held transmitter button until the LED (2.1/2.2/2.3/2.4) goes out, depending which channel has been selected.
 - ⇒ LED goes out – programming is finished.
 - ⇒ The handheld transmitter has transferred the radio code to the radio transmitter.
3. Repeat the above steps to program by teach-in any additional handheld transmitters. A maximum of 112 storage locations for each radio receiver are available.

Cancelling the teach-in mode

Press the teach-in button (1) until all LEDs are out or make no input for 10 seconds.

Deleting the handheld transmitter from the radio receiver

If a handheld transmitter is to be deleted from the radio receiver, **every** button and **every** short cut of the handheld transmitter must be deleted for security reasons!

1. Press the teach-in button (1) and keep it pressed for 5 seconds.
 - ⇒ One of the LEDs flashes.
2. Release the teach-in button (1).
 - ⇒ The radio receiver is in Deletion mode.
3. Press the transmitter button whose code should be deleted in the radio receiver.
 - ⇒ The LED goes out. The deletion procedure is ended.
4. Repeat the procedure for **all** buttons and shortcuts.

Commissioning/operation

Teach-in by radio (HFL)

Prerequisites for teach-in by radio

At least one handheld transmitter has been programmed by teach-in via the radio receiver (see Teach-in of handheld receivers).

Restrictions

The following is not possible by radio

- The targeted teach-in of a selected handheld transmitter button on a radio channel.
- Deletion of a handheld transmitter, radio channel or of the entire radio receiver (memory).
- Changing the programming of a handheld transmitter programmed by teach-in by radio (e.g. teach-in of another button).

Importation information

- Each handheld transmitter that has already been programmed by teach-in can put the radio receiver into teach-in mode by radio.
- Radio receivers that are within the range of the handheld transmitter are put into teach-in mode simultaneously.
- The key assignment of handheld transmitter (A) that put the radio receiver into teach-in mode by radio is used for the new handheld transmitter (B) that is to be programmed by teach-in.
Example: Button 1 on channel 1 and button 2 on channel 2 has been programmed by teach-in by handheld transmitter (A).
 - ⇒ The new handheld transmitter (B) that has been programmed by teach-in has acquired the key assignment of handheld transmitter (A):
 - ⇒ Button 1 on channel 1 and button 2 on channel 2.

Procedure

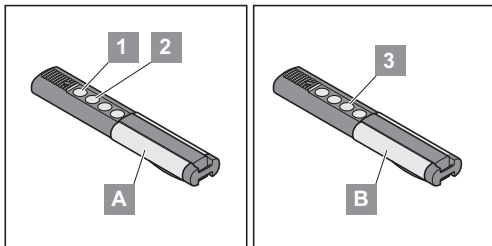

1. Press buttons 1 + 2 of a handheld transmitter programmed by teach-in (A) for 5 seconds until LED channel 1 lights up on the radio receiver.
 - ⇒ If no code is transmitted within another 10 seconds, the radio receiver switches over to normal mode.
 - ⇒ To interrupt teach-in mode: Press button (1), LED channel 1 goes out.
2. Release buttons 1 + 2 of the handheld transmitter (A).
3. Press any key, e.g. (3) on the new handheld transmitter button (B) to be programmed by teach-in.
4. LED channel 1 on the radio receiver flashes initially and then goes out.
 - ⇒ Handheld transmitter (B) has been programmed by teach-in.

Important note for more detailed information

You can get the separate Installation and Operating Manual (radio receiver, 4-channel – Somloq Rollingcode/868.8 MHz/434,42 MHz) by scanning the QR code.



<https://downloads.sommer.eu/?category=40>

Radio receiver (version SOMloq2)

Information on SOMloq2

The bidirectional data transmission between the transmitter and receiver allows a wide range of functions. Transmission is tap-proof and particularly reliable thanks to the special coding. Separate antennas or other installations are not necessary.



IMPORTANT INFORMATION!

The receiver is SOMlink-compatible!

Safety instructions



CAUTION!

- Opening the device is strictly prohibited and will cause loss of any claims for warranty service.
- Have faulty devices repaired by a technician authorised by the manufacturer.
- The local safety regulations for the system must be observed to ensure safe operation! Information is available from electrical utility companies, VDE (Association for Electrical, Electronic & Information Technologies) and professional associations.

Intended use

- Systems that pose an accident risk should not be operated by remote control unless the complete range of movement of the system is visible to the user!
- Remote control of devices and systems with increased accident risk (e.g. hoists) is prohibited!
- The remote control must only be used for devices and systems in which radio interference in the handheld transmitter or radio receiver will not endanger people, animals or objects, or the risk is reduced by other safety devices.
- The operator of the radio system has no protection against interference from other telecommunications systems or terminal equipment (e.g. including other radio systems that are licensed to operate in the same frequency range).
- After a power interruption, (e.g. in the event of a power failure), the radio receiver sets all outputs to **OFF**. Switch on an actuated alarm system again after a power interruption or use a backup battery.

Commissioning/operation

Explanation of display and buttons

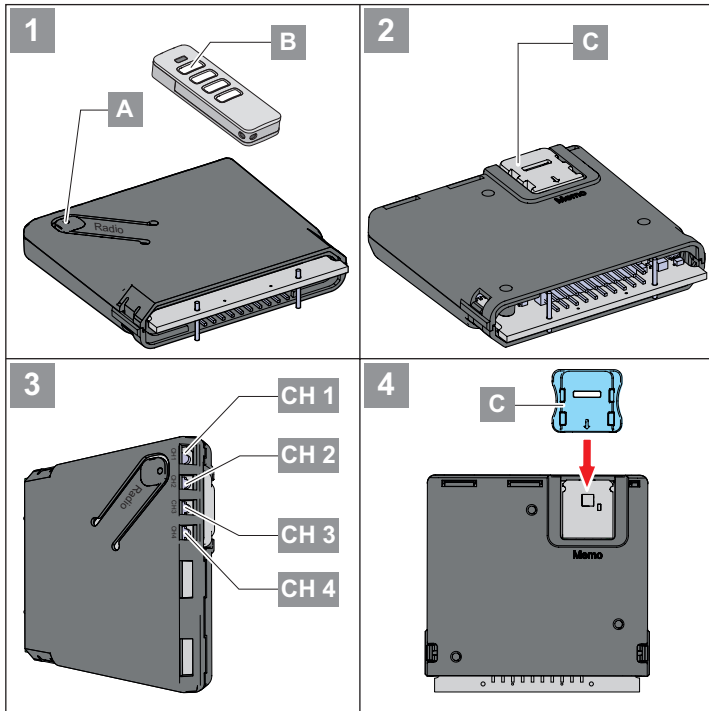

i IMPORTANT INFORMATION!

- If no button is detected as pressed on the handheld transmitter within 30 seconds, the LED for the selected radio channel (CH) goes out and programming mode is ended.

1. Press the Radio button (A) on the control unit repeatedly to select the desired radio channel (CH).

	1x	2x	3x	4x
LED				
CH 1				
CH 2				
CH 3				
CH 4				

LED	Description
	LEDs show selected channel
CH 1	Radio channel 1 -> same function as "Start 1" (pulse)
CH 2	Radio channel 2 -> same function as "Start 2" (partial opening)
CH 3	Radio channel 3 -> no function
CH 4	Radio channel 4 -> no function

Programming the transmitter



IMPORTANT INFORMATION!

The transmitter that is to be programmed must be located near the receiver during the programming process!

1. Press button (A) briefly.
 - 1x for channel 1, ⇒ LED CH 1 lights up green.
 - 2x for channel 2, ⇒ LED CH 2 lights up green.
 - 3x for channel 3, ⇒ LED CH 3 lights up green.
 - 4x for channel 4, ⇒ LED CH 4 lights up green.
 - ⇒ If no command is transmitted within 30 seconds, the radio receiver switches over to normal mode.
 - ⇒ Cancelling programming mode: Press the Teach-in button (A) repeatedly until no more LEDs are lit.
2. Press and hold the desired handheld transmitter button (B) until the LED for the selected channel blinks quickly and goes out.
 - ⇒ Programming is finished.
3. Repeat steps 1–2 to program other handheld transmitters to this radio receiver.

Installing accessories

Only **SOMMER** accessories may be connected.

Commissioning/operation

Programming by radio (HFL)

Function

Each handheld transmitter that has already been programmed can put the receiver into programming mode by radio. This allows additional transmitters to be programmed without having to press button (A) on the receiver. The button assignment on handheld transmitter A (Fig. HFL) (which activated the receiver) is also used for handheld transmitter (B) which needs to be programmed. Both handheld transmitters must be located within the range of the radio receiver.



i IMPORTANT INFORMATION!

Only the programming of identical handheld transmitters by radio is recommended!

If different handheld transmitter types are used, only the first button command is transferred from handheld transmitter 1 to important information! handheld transmitter 2.

Procedure

1. Press and hold buttons (1+2) of the previously programmed handheld transmitter A for 3–5 seconds until LEDs (CH 1 and CH 2) on the receiver fast flash inverted green.
2. Release buttons (1+2).
 - ⇒ If a command is not transmitted within another 30 seconds, the radio receiver switches over to normal mode.
3. Press any button on the new handheld transmitter B.
 - ⇒ LEDs (CH 1–CH 4) on the receiver blink quickly and go out.
 - ⇒ Commands and key assignment on handheld transmitter B and handheld transmitter A are now identical.

Operation

1. Press transmitter button (B) briefly.
 - ⇒ LED for the programmed channel lights up orange as long as the button is pressed.
 - ⇒ The assigned output switches.

Deleting a transmitter button from the radio channel

1. Select radio channel with button (A) and hold the button pressed for 15 to 20 seconds until the LED for the selected channel flashes red.
2. Release Teach-in button (A).
 - ⇒ To cancel delete mode: Press button (A); LED goes out.
 - ⇒ If no command is transmitted within 30 seconds, the radio receiver switches over to normal mode.
3. On the transmitter, press the button for which the command is to be deleted in the radio receiver.
 - ⇒ LED blinks quickly – delete complete.
 - ⇒ Radio receiver switches to normal mode – delete complete.

Deleting a transmitter from the radio receiver

1. Press and hold button (A) for 20 to 25 seconds until LED (CH 1) blinks red.
2. Release button (A).
 - ⇒ To cancel delete mode: Press button (A); LED (CH 1) goes out.
 - ⇒ If no command is transmitted within 30 seconds, the radio receiver switches over to normal mode.
3. Press any button on the transmitter that is to be deleted from the receiver memory.
 - ⇒ Radio receiver deletes the transmitter, LED (CH 1) blinks quickly.
 - ⇒ Radio receiver switches to normal mode – delete complete.

Deleting a radio channel

i IMPORTANT INFORMATION! This action cannot be interrupted!

1. Select the radio channel to be deleted with button (A) and hold button (A) pressed for 25–30 seconds until the LED for the selected channel lights up red.
2. Release button (A).
 - ⇒ The channel is deleted from the radio receiver.
 - ⇒ Receiver switches to normal mode – delete complete.

Deleting the entire memory of the radio receiver

i IMPORTANT INFORMATION! This action cannot be interrupted!

If a transmitter is lost, all channels in the radio receiver must be deleted for security reasons! Then reprogramme all transmitters.

1. Press and hold button (A) for more than 30 seconds until the LEDs (CH 1–CH 4) simultaneously light up red.
2. Release button (B).
 - ⇒ Radio receiver deletes the memory.
 - ⇒ Radio receiver switches to normal mode – delete complete.

If the memory capacity has been reached

A total of 40 handheld transmitter commands are available for all channels. If an attempt is made to program additional transmitters, the red LEDs of radio channels CH 1–4 blink.

Information on Memo

The memory capacity can be extended to 450 handheld transmitter commands using the optional Memo accessory part. When the Memo is plugged in, all available transmitters are transferred from the internal memory to the Memo and stored there. The Memo must remain plugged in on the control unit. No more transmitters are then stored in the internal memory. Stored transmitters cannot be transferred from the Memo back to the internal memory. All radio channels, including the memory of the Memo, can be deleted.

Installing the Memo

i IMPORTANT INFORMATION! If the Memo is removed, the receiver memory is empty. Radio commands need to be programmed again!

1. Turn off the power supply to the operator control unit.
2. Disconnect the receiver from the operator control unit.
3. Plug the Memo (C) into the slot.
4. Reconnect the receiver to the operator control unit.
5. Restore the power supply.
 - ⇒ A total of 450 memory positions is now available for radio commands.

Important note for more detailed information

You can get the separate Installation and Operating Manual (radio receiver SOMup4 – SOMloq2/868.95 MHz) by scanning the QR code.



<https://downloads.sommer.eu/?category=36>

Commissioning/operation

Completing commissioning

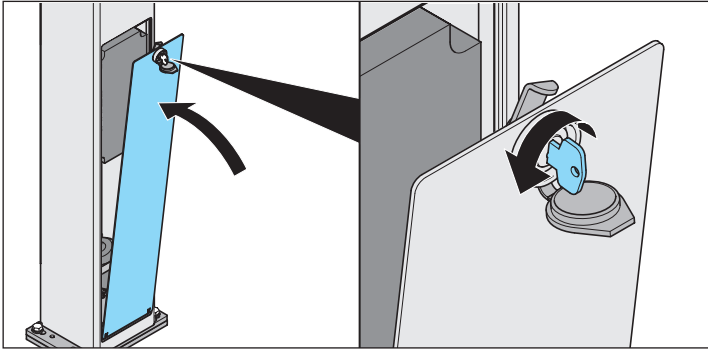

1. Insert revision flap from below and fold upwards.
2. Close revision flap.
3. Place dust cap.
⇒ Commissioning complete.

Safety instructions

- The radio remote control may only be used if the gate's movement can be watched and no persons or objects are within the range of movement.
- Keep children, disabled persons and animals away from the gate.
- Never reach into a moving gate or moving parts.
- Do not drive through the gate until it has been fully opened.
- Entrapment and/or cutting hazard from the mechanism or closing edges of the gate.
⇒ The safety instructions in this manual and the applicable standards and directives for securing closing edges must be observed at all times.

Opening the gate



ATTENTION!

Buttons and other command controls must be installed and actuated within view of the gate only. Violation of this requirement may result in serious injury to third parties.

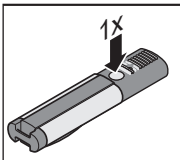

1. Press the pulse transmitter or hand-held transmitter button once.
 - Initial position gate CLOSED.
 - If the button is pressed during the gate OPEN movement, the gate stops.
 - It closes when pressed again.

Closing the gate

1. Press the button or hand-held transmitter button once.
 - Initial position gate OPEN.
 - If the button is pressed during the gate CLOSE movement, the gate stops.
 - It opens when pressed again.

Defined opening and closing

This function opens and closes the gate with separate handheld transmitter buttons.

Defined opening:

- programme the desired hand-held transmitter button on radio channel 3

Defined closing:

- programme the desired hand-held transmitter button on radio channel 4

Partial opening

This function partially opens the gate.



IMPORTANT INFORMATION!

A new partial opening function can only be programmed with automatic closing deactivated.



IMPORTANT INFORMATION!

A partial opening of approx. 20 % of the total length of the gate is factory-set. If this is to be retained, it is only necessary to programme channel 2 or to connect the button accordingly.

Example:

open the gate for persons to pass through. Partial opening can be used with a second button or by radio (hand-held transmitter, Telecody, etc.).

Partial opening by radio

1. Close gate completely to gate CLOSED end position.
2. Select radio channel 2 and programme partial opening with the desired hand-held transmitter button.
⇒ See "Radio receiver".
3. Open the gate to the desired partial opening position by pressing the hand-held transmitter button programmed on channel 2 (partial opening button).
4. Press the partial opening button again when the desired partial opening position has been reached.
⇒ Gate stops.
⇒ The partial opening function has been programmed.

Partial opening by pulse button

1. Wire button as described in "Connection".
2. Close the gate completely up to the gate CLOSED end position.
3. Press button to open gate to the desired partial opening position.
4. Press button again when the desired partial opening position is reached.
⇒ Gate stops.
⇒ The "partial opening" function has been set.

Deleting partial opening

- Close gate to the gate CLOSED end position.
- Press and hold PROG + hand-held transmitter button on which the partial opening was programmed for 2 seconds.

or

- Close gate to the gate CLOSED end position.
- Press and hold PROG + partial opening buttons for 2 seconds.
⇒ Light LED lights when partial opening has been deleted.

Commissioning/operation

Automatic closing function



ATTENTION!

Risk of injury during automatic closing. Automatically closing gates may injure persons within the range of movement of the gate when closing. Always install a photo eye before activating the function. This is a legal requirement.



ATTENTION!

The controller does not respond to continuous signal in the "gate OPEN" direction.



IMPORTANT INFORMATION!

A timer can be set up only using TorMinal. See the separate TorMinal instructions.

When the timer is connected, the partial opening can be used by radio again.



IMPORTANT INFORMATION!

Operation with automatic closing must comply with EN 12453.



IMPORTANT INFORMATION!

There are two types of automatic closing. Both allow the open holding time to be set from 0–255 seconds.

1. Semi-automatic closing (potentiometer left)
2. Fully automatic closing (potentiometer right)
3. Deactivating automatic closing (potentiometer at centre position)



IMPORTANT INFORMATION!

The progress of the open holding time is indicated by the flashing status LED (2 x ... 2 x...).



IMPORTANT INFORMATION!

Automatic closing is disabled if dead man mode is activated (DIP 1 ON).

Semi-automatic closing function

- All commands from command transmitters are accepted.
- When the gate OPEN end position or the programmed partial opening position is reached, the open holding time starts (referred to as OHT below).
- The gate closes on expiration of the OHZ.
- If a pulse command is received (e.g. START button or radio channel 1), the OHZ is reduced.
- The OHZ is reduced if a partial opening command is received.
- The OHZ does not expire at an intermediate stop.

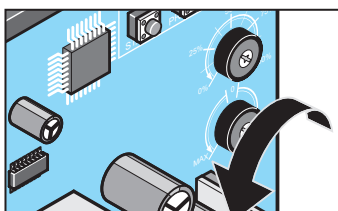

Turn potentiometer anticlockwise to the desired OHZ.

Fully automatic closing function

- All commands are ignored during opening.
- When the gate OPEN end position or the programmed partial opening position is reached, the OHZ starts.
- If a pulse command is received (e.g. START button or radio channel 1), the OHZ is restarted.
- If a new partial opening command is received at the "partial opening" operator setting, the OHT is restarted.

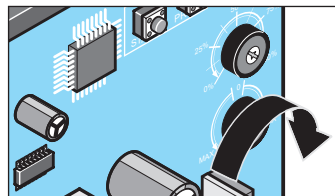

Turn potentiometer clockwise to the desired OHZ.

STOP command during automatic closing

A STOP command triggered by a STOP button (see section "Connection") always interrupts the movement of the operator, regardless of what type of automatic closing has been selected.

Light barrier event during automatic closing

DIP switch 6

"ON" Gate closes 5 seconds after triggering photo eye.

"OFF" The OHT restarts after triggering photo eye.

Pre-warning time

Before the operator starts, a warning light flashes for 5 seconds after the button or the hand-held transmitter is pressed (factory setting).

The pre-warning time is cancelled if a command transmitter is actuated again.

- Wire warning light as described in "Connection".

DIP switch 8

"ON" Activates the pre-warning time.

"OFF" Deactivates the pre-warning time.

Dead man operation

In dead man operation the gate can only be moved by continuous signals from buttons.

Dead man button mode is not possible by radio.



ATTENTION!

Force cut-off is not available in dead man operation.

Danger of serious injury!

Always ensure that there are no persons, animals or object in the area of movement of the gate.



ATTENTION!

Buttons and other command controls must be installed and actuated within view of the gate only.

Violation of this requirement may result in serious injury to third parties.

DIP switch 1

"ON" Activates dead man button mode.

- ⇒ Gate movements require the button to be pressed as long as the gate OPEN and gate CLOSE movements are required.

"OFF" Deactivates dead man operation.

Commissioning/operation



IMPORTANT INFORMATION!

If safety devices fail, the control unit is automatically set to dead man operation. However, this only affects the movement that is affected by the fault in the safety device.

Example: If a safety contact strip in the gate CLOSE direction fails, the gate can only be closed in dead man operation until the fault is repaired.

Obstacle detection



ATTENTION!

Buttons and other command controls must be installed and actuated within view of the gate only. Violation of this requirement may result in serious injury to third parties.



ATTENTION!

The reversing length must be set as short as possible to prevent additional hazards arising from gates with grids at an ancillary closing edge.
The reversing times can be changed with the TorMinal.



IMPORTANT INFORMATION!

Reversing: The operator stops on contact with an obstacle and then moves in the opposite direction to release the obstacle.

Partial reversing: The operator reverses a predefined distance to release the obstacle.

Full reversing: The operator reverses completely back to the end position.

The following safety devices are installed to detect obstacles:

- Photo eye (object protection).
- Safety contact strips (personal protection).
- Force cut-off of operator (personal protection).

Obstacle detection by photo eye



ATTENTION!

A photo eye must be used for object protection only.
A photo eye must not be used for personal protection.

- Connect photo eye as described in "Connection".

Action in gate CLOSE

DIP 4

"ON" Full reversing

"OFF" Partial reversing



IMPORTANT INFORMATION!

A photo eye has no effect in the gate OPEN direction.



IMPORTANT INFORMATION!

If the photo eye is interrupted, the gate runs on for a short distance.

Obstacle detection by safety contact strips:

- Connect safety contact strips as described in "Connection".



ATTENTION!

Make absolutely sure that the safety contact strips are connected for the correct direction (OPEN/CLOSE).
A safety contact strip connected for gate CLOSE will not respond in the gate OPEN direction and vice versa.

Behaviour

DIP 2

"ON" Full reversing

"OFF" Partial reversing

Force cut-off of operator



ATTENTION!

There is no force cut-off in dead man button mode.
This operating mode is activated by default during the programming phase. It is also activated if DIP switch 1 is set to ON. There is a risk of serious injury for anyone in the range of movement of the gate in this operating mode.

- The sensitivity of the force cut-off depends on the correct weight setting of the gate or the weight potentiometer.
⇒ See "Commissioning".

Power-saving mode

To save energy, the operator control unit switches to power-saving mode after the specified period. Connected accessories (e.g. photo eye, safety contact strip, external radio receiver etc.) are deactivated and then reactivated at the next command (button, radio etc.).



IMPORTANT INFORMATION!

The factory-set period before the control unit switches to power-saving mode is 6.5 minutes.
The period can be changed with a TorMinal.
(see TorMinal instructions)

Important information when using an external radio receiver

Because external radio receivers are deactivated in power-saving mode, they cannot receive commands from the hand-held remote control when the control unit has switched to power-saving mode.

If an external radio receiver is used, power-saving mode must be deactivated with DIP switch 5.

Deactivating power-saving mode

DIP 5

"OFF" Power-saving activated (factory setting).

"ON" Power-saving deactivated.

Commissioning/operation

Important information when using a battery pack

If there is a power failure, the control unit automatically switches to power-saving mode after 5 seconds in order to extend the battery life.

If a battery pack is connected, standby mode is automatically deactivated to enable charging of the battery pack.

Overload protection

If the operator is overloaded during opening or closing, the control unit detects this and stops the drive.

A control unit reset then puts the operator back in standby mode (See section "Commissioning").

Operation after a power failure

If there is a power failure while a battery pack is connected, the control unit automatically switches to power-saving mode after 5 seconds in order to extend the battery life. This function cannot be deactivated.

The programmed force values and the end positions are stored in the event of a power failure. The first movement of the operator after a power failure is always door OPEN.

If the power failure occurs during a door movement, the operator stops. The operator can be restarted with a command device when the power supply has been restored. The operator then moves in automatic mode at reduced speed to "Door OPEN" end position.

Emergency release

ATTENTION!
 During an emergency release the gate may start moving if it is not 100 % horizontal. Risk of injury!

IMPORTANT INFORMATION!
 It can be released in any gate position.
If the operator is not locked again at an end position after an emergency release and restarted with a control device, it moves in automatic mode at reduced speed to the "Gate OPEN" end position.
If a programming movement is interrupted by an obstacle, the operator stops and reverses. The operator can be restarted with a control device. The next movement is in automatic mode at reduced speed to "Gate CLOSED" end position.

Releasing the operator

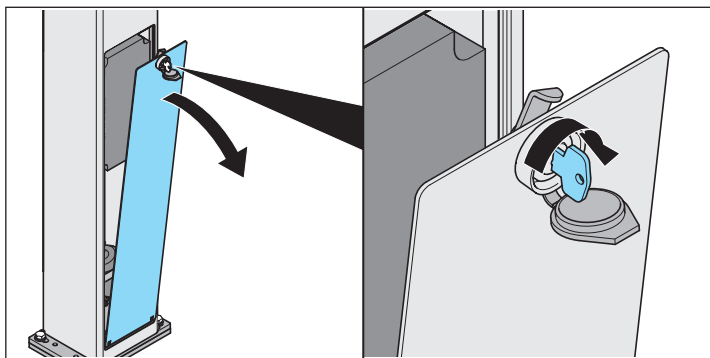

1. Open dust cap.
2. Unlock lock.
3. Open revision flap.

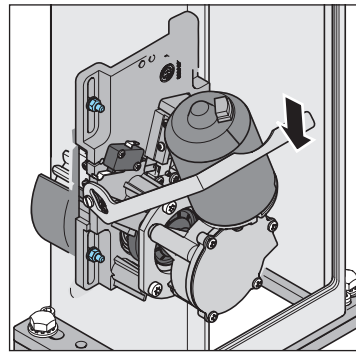

4. Push lever down.

Locking operator

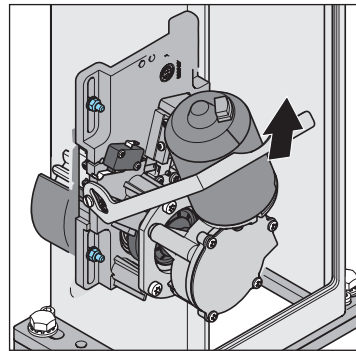

1. Push lever up.

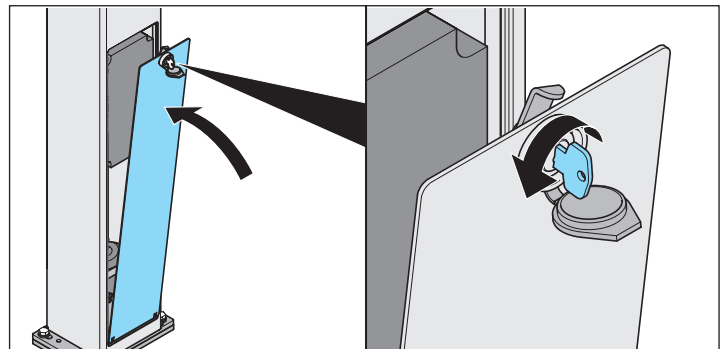

2. Position revision flap.
3. Close revision flap.
4. Place dust cap.

IMPORTANT INFORMATION!
 Move gate back and forth by hand so the pinion meshes with the rack more easily and the motor can lock.
⇒ Operator is locked and the gate can only be moved with the motor. Disassembly.

Maintenance and care

Safety instructions



DANGER!

Never use a water hose or high-pressure cleaner to spray down the operator or the control unit housing.

- Before any work on the gate or operator disconnect it from the power supply and lock it to prevent reconnection.
- Do not use acids or alkalis for cleaning.
- Wipe the operator clean with a dry cloth as required.
- Never reach into a moving gate or moving parts.
- Crush and shear hazards at the closing edges and the mechanical systems of the gate.
- Check all fastening screws and bolts of the operator for tight seating and retighten them where necessary.
- Check the gate in accordance with the manufacturer's instructions.

Regular testing

Safety devices must be tested at intervals which do not exceed six months and which must be prescribed in the maintenance instructions for the door, in accordance with EN 12453-1/2.

Check every 4 weeks that pressure-sensitive safety devices (e. g. safety contact strips) are operating correctly, in accordance with EN 60335-2-103.

Testing	Behaviour	yes or no	Possible cause	Remedy
Force cut-off				
Stop gate during closing with an object 50 mm x 50 mm.	Does operator reverse when it contacts the object?	Yes	<ul style="list-style-type: none"> • The force cut-off is functioning. 	
		No	<ul style="list-style-type: none"> • Force tolerance too high, adjust with TorMinal. • Gate incorrectly adjusted. 	<ul style="list-style-type: none"> • Reduce the force tolerance until the test is successful. First open and close the gate completely twice under supervision. See TorMinal owner's manual. • Adjust gate, call a technician.
Emergency release				
Proceed as described in the "Emergency release" section.	The gate must be easily opened and closed by hand. (Gate is balanced)	Yes	<ul style="list-style-type: none"> • Everything is OK. 	
		No	<ul style="list-style-type: none"> • Emergency release defective. • Gate jams. 	<ul style="list-style-type: none"> • Repair emergency release. • Check the gate, see maintenance instructions for the gate.
Safety contact strip, if present				
Open and close the gate and actuate the strip at the same time.	Adjust the behaviour of the gate, as set with DIP switch 1, 2 or 3. Safety LED lights continuously.	Yes	<ul style="list-style-type: none"> • Everything is OK. 	
		No	<ul style="list-style-type: none"> • Cable breakage, terminal loose. • Strip defective. 	<ul style="list-style-type: none"> • Check the wiring; retighten the terminals. • Decommission the system and lock it to prevent reactivation. Then contact customer service.
Photo eye, if present				
Open and close the gate while interrupting the photo eye.	Adjust the behaviour of the gate, as set with DIP switch 1, 2 or 3. Safety LED lights continuously.	Yes	<ul style="list-style-type: none"> • Everything is OK. 	
		No	<ul style="list-style-type: none"> • Cable breakage, terminal loose. • Photo eye dirty. • Photo eye maladjusted (holder bent). • Photo eye fault. 	<ul style="list-style-type: none"> • Check the wiring; retighten the terminals. • Clean the photo eye. • Adjust photo eye. • Decommission the system and lock it to prevent reactivation. Then contact customer service.

Troubleshooting

Malfunction	Possible cause	Corrective action
Operator does not close the gate	• Photo eye power supply interrupted.	Check connection Replace fuse
	• Operator has been disconnected from mains power supply.	• The operator always opens the gate completely upon first command after the power supply has been restored.
	• The operator was in an intermediate position when it was disconnected and as a result has switched to dead man operation.	• Move gate to an end position in dead man operation and lock.
Operator opens gate, then no further reaction to a command from the hand-held remote control.	• Safety input triggered (e.g. photo eye fault), safety LED flashing (see table)	• Remove object from photo eye. • Repair photo eyes. • Control unit not properly plugged in.
Speed varies during opening and closing.	• Operator starts and slows down before reaching the end position.	Completely normal, operator starts at maximum speed. The operator reduces speed before reaching the other end position (soft running).
Gate cannot be operated unless the user presses and holds the buttons, e.g. key switches.	• Dead man button mode switched on.	Deactivate dead man button mode, see section 'Select DIP switch settings' or 'Remedy defective safety periphery'.

Only radio receiver!		
All LEDs flashing.	• All memory locations occupied, max. 112.	• Delete any transmitters that are no longer needed. • Install additional radio receivers.
One of the LEDs on the receiver is on continuously.	• The radio signal is being received; the button of a handheld remote control may be defective or an external signal present.	• Remove the battery from the handheld transmitter. • Wait until the external signal falls off.
One of the LEDs on the receiver is on.	• The radio receiver is in the Learning mode and awaiting a radio code from a hand-held remote control.	Press the desired hand-held transmitter button.

Description of the flash sequences of the LEDs

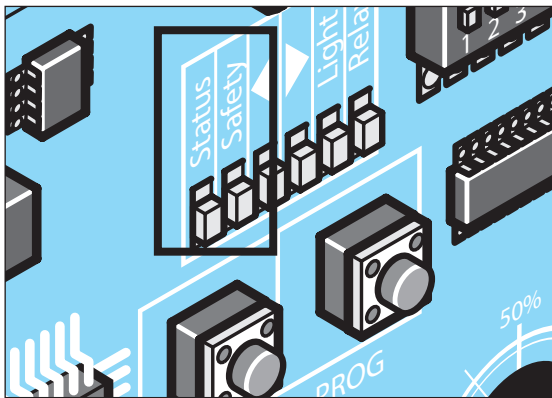

Flash sequences of the safety LED		Meaning
████████████████████	Continuously on	Emergency release is actuated, EMERGENCY STOP or stop button is pressed.
■ ■ ■ ■	2x	Safety contact strip is bent or a force cut-off has occurred
■ ■ ■ ■ ■ ■	3x	Photo eye is interrupted.
■ ■ ■ ■ ■ ■ ■ ■	4x	Runtime is >90 seconds, path is too short or too long.
■ ■ ■ ■ ■ ■ ■ ■ ■ ■	5x	System error: control unit has a defect or is overloaded/motor – encoder error/motor fault.
■ ■	1x	Battery charge is no longer sufficient.

Flash sequences of the status LED		Meaning
████████████████████	Continuously on	System OK.
■ ■ ■ ■	4x	Power-saving mode is activated.
■ ■ ■ ■	2x	Open time of auto closing is expiring.
■ ... 3 sec... ■ ... 3 sec... ■ ... 3 sec... ■	1x	Operator is in power-saving mode.

Disassembly and disposal

Disassembly



IMPORTANT!

Observe the safety notices!

The sequence is identical to that described in the “Installation” section, but in reverse order. Ignore the setting instructions.

Disposal



DANGER CAUSED BY HAZARDOUS SUBSTANCES!

Improper storage, use or disposal of accumulators, batteries and operator components pose a risk to the health of humans and animals. Serious injury or death may result.

- ▶ Accumulators and batteries must be stored out of the reach of children and animals.
- ▶ Keep accumulators and batteries away from chemical, mechanical and thermal influences.
- ▶ Do not recharge old accumulators and batteries.
- ▶ Components of the operator as well as old accumulators and batteries must not be disposed of with household waste. They must be disposed of properly.
- ▶ Batteries may contain hazardous chemical substance which damage the environment and pose a risk to the health of humans and animals. Caution must be exercised, in particular when handling batteries containing lithium, as these can easily ignite and cause fires if not handled correctly.
- ▶ Batteries and accumulators in electrical appliances and which can be removed non-destructively must be disposed of separate from the appliance.



NOTE!

This device is labelled in accordance with European Directive 2012/19/EU on used electrical and electronic devices (WEEE – waste electrical and electronic equipment).



This Directive provides the framework for the EU-wide return and recycling of used equipment.



Operator components that have been taken out of service as well as old accumulators and batteries must not be disposed of with household waste. Components which are no longer in use, old accumulators and batteries must be disposed of properly. You must observe the local and national regulations here. Contact your specialist retailer to find out more about current disposal channels.



Points de collecte sur www.quefairedemesdechets.fr
Privilégiez la réparation ou le don de votre appareil !

Warranty and customer service

The warranty complies with statutory requirements. The contact person for warranties is the specialist retailer. The warranty is only valid in the country in which the operator was purchased.

Batteries, fuses and bulbs are excluded from the warranty.

If you require after-sales service, spare parts or accessories, please contact your specialist retailer.

DIP switch settings

Switch	ON	OFF (delivery status)
1	Dead man mode activated.	Dead man button mode deactivated.
2	Reaction to SKL input/force cut-off	
	Full reversing	Partial reversing
3	Weight potentiometer blocked.	Weight potentiometer unblocked.
4	Reaction to photo eye when closing	
	Full reversing	Partial reversing
5	Power-saving mode	
	Power-saving mode deactivated	Power-saving mode activated
6	Gate closes 5 seconds after triggering photo eye.	Triggering photo eye resets the open holding time.
7	Gate opens to the right.	Gate opens to the left.
8	Pre-warning time activated.	Pre-warning time deactivated.

Wiring diagram

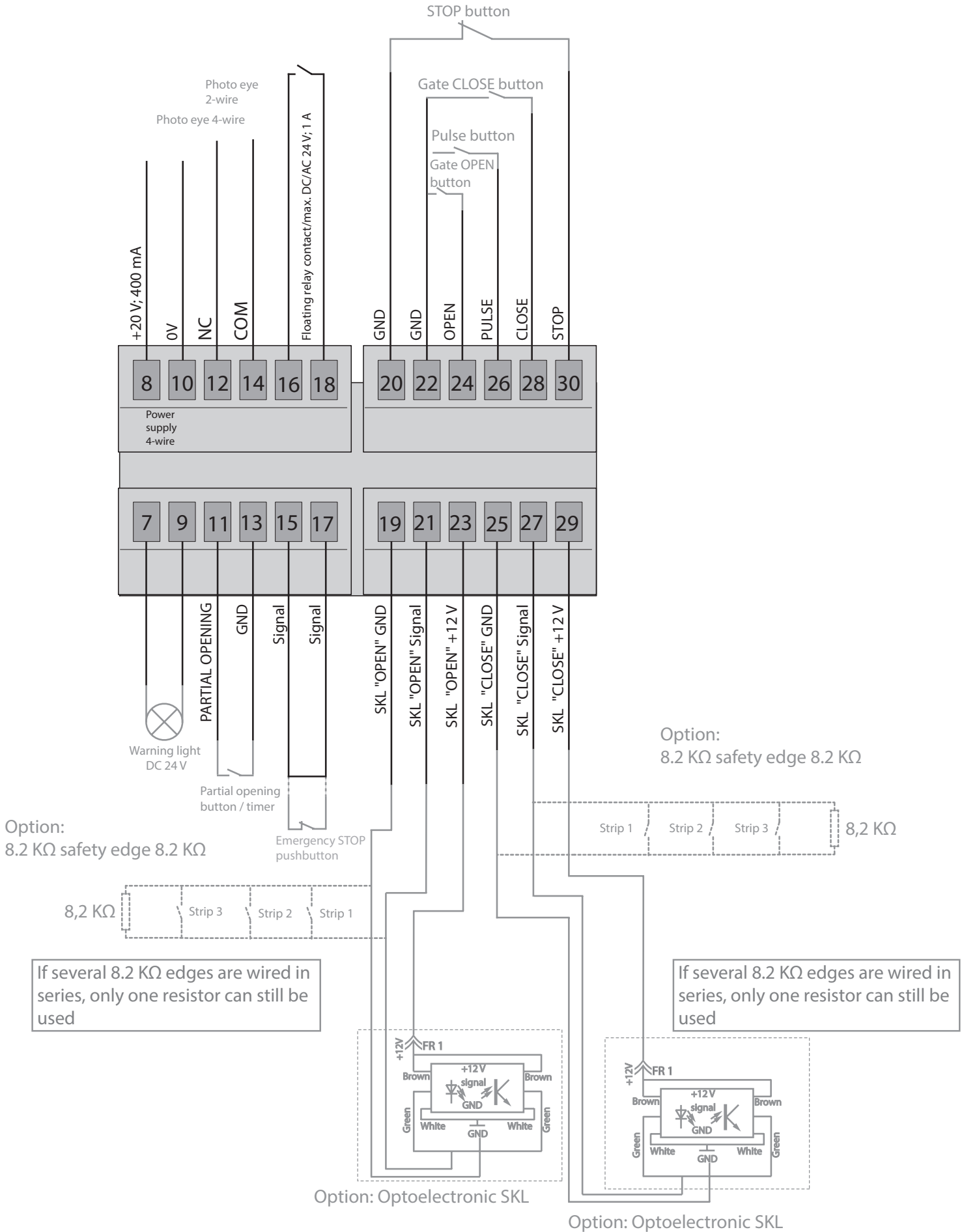

SOMMER Antriebs- und Funktechnik GmbH

Hans-Böckler-Straße 27
73230 Kirchheim/Teck
Germany

www.sommer.eu

© Copyright 2022 All rights reserved.