

KIT BI-FOLDING 180° BI-FOLDING 180° KIT

Kit accessori in acciaio zincato, con cerniere in alluminio, per la realizzazione di un cancello Bi-folding con ante battenti a libro. Il sistema 180° ha fatto proprie tutte le caratteristiche del sistema Bi-folding, dotandosi di un apposito braccio e speciali cardini che ne permettono il movimento fino a 180°. I cardini e le cerniere sono stati specificatamente disegnati e garantiscono una realizzazione di eccezionale solidità, associata ad un movimento preciso, senza necessità di rotaie a terra.

Inoltre, le ante pieghevoli permettono di ridurre al minimo l'ingombro in fase di apertura e chiusura. Questo sistema è perfetto per applicazioni ad uso residenziale e/o commerciale, mantenendo sempre una particolare attenzione alle esigenze di protezione e sicurezza.

Galvanized steel accessory kit, with aluminum hinges, for the construction of a Bi-folding gate with folding leaves. The 180° system has made all the features of the Bi-folding system its own, being equipped with a special arm and special hinges that allow it to rotate up to 180°. The hinges were specifically designed and ensure exceptionally solid construction, combined with precise movement, without the need of ground rails.

In addition, the folding leaves allow to reduce the footprint to the minimum during the opening and closing phase. Our Bi-folding 180° is designed for both industrial and commercial use, with a particular attention to the protection and security needs.



KC7201.160

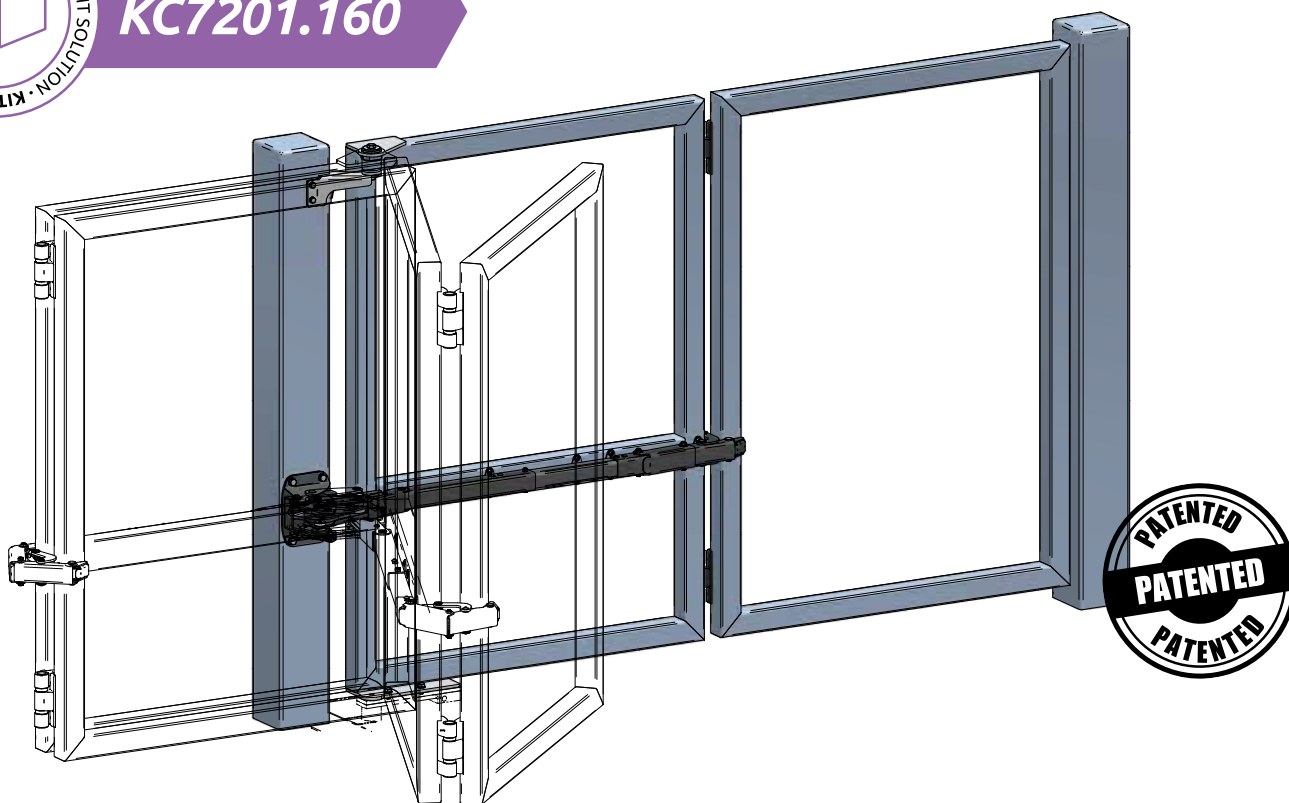

1 kit

Anta singola
Single leaf

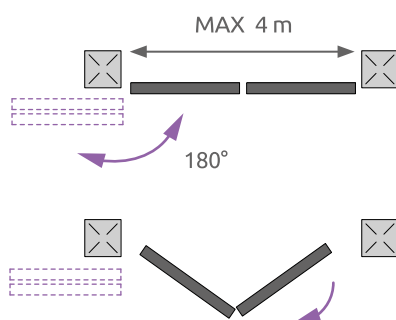



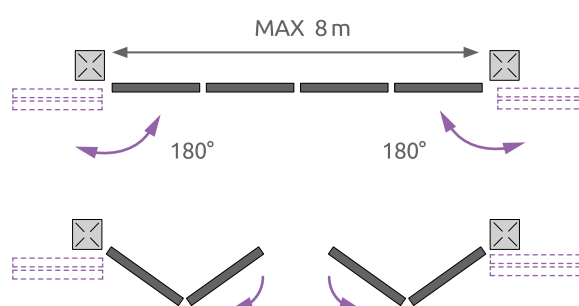

2 kit

Anta doppia
Double leaf





COMPONENTI
COMPONENTS

<p>x1</p> 	<p>x1</p> 	<p>x1</p> 
<p>VC7201.060</p>	<p>VC7202.060</p>	<p>VC7203.060</p>
<p>x1</p> 	<p>x1</p> 	<p>x2</p> 
<p>VC7205.060</p>	<p>VC7204.060</p>	<p>VL4500</p>
<p>x1</p> 	<p>x1</p> 	<p>x1</p>  <p>* solo per montaggio provvisorio, vedi istruzioni a seguire * only for pre-assembly, see the instructions below</p>
<p>VC7105.060</p>	<p>VA5401</p>	<p>Cardine inferiore/bottom hinge</p>

ARTICOLI CORRELATI
RELATED ARTICLES



VC9101
VC9111



VC5101
VC5102
VC5103



Collegati al nostro sito per le diverse tipologie
e misure disponibili
Click on our website for other related items



TABELLA DIMENSIONI
SIZES CHART

A min-max (m)	B min (mm)	C (mm)	D min (mm)	E min (mm)	M max (mm)	Q (mm)	A/H max	H max (m)
2,2 - 4	70	50	60	80	800	60	3	2,5

APERTURA A (m) OPENING A (m)	L (m) con/with B=0,07 m	Peso max S2 (kg) Max weight S2 (kg)
2,2	~ 1,04	125
2,6	~ 1,24	125
3	~ 1,44	125
3,5	~ 1,69	120
4	~ 1,94	105

Dati calcolati con A/H = 2
Data calculated with A/H = 2

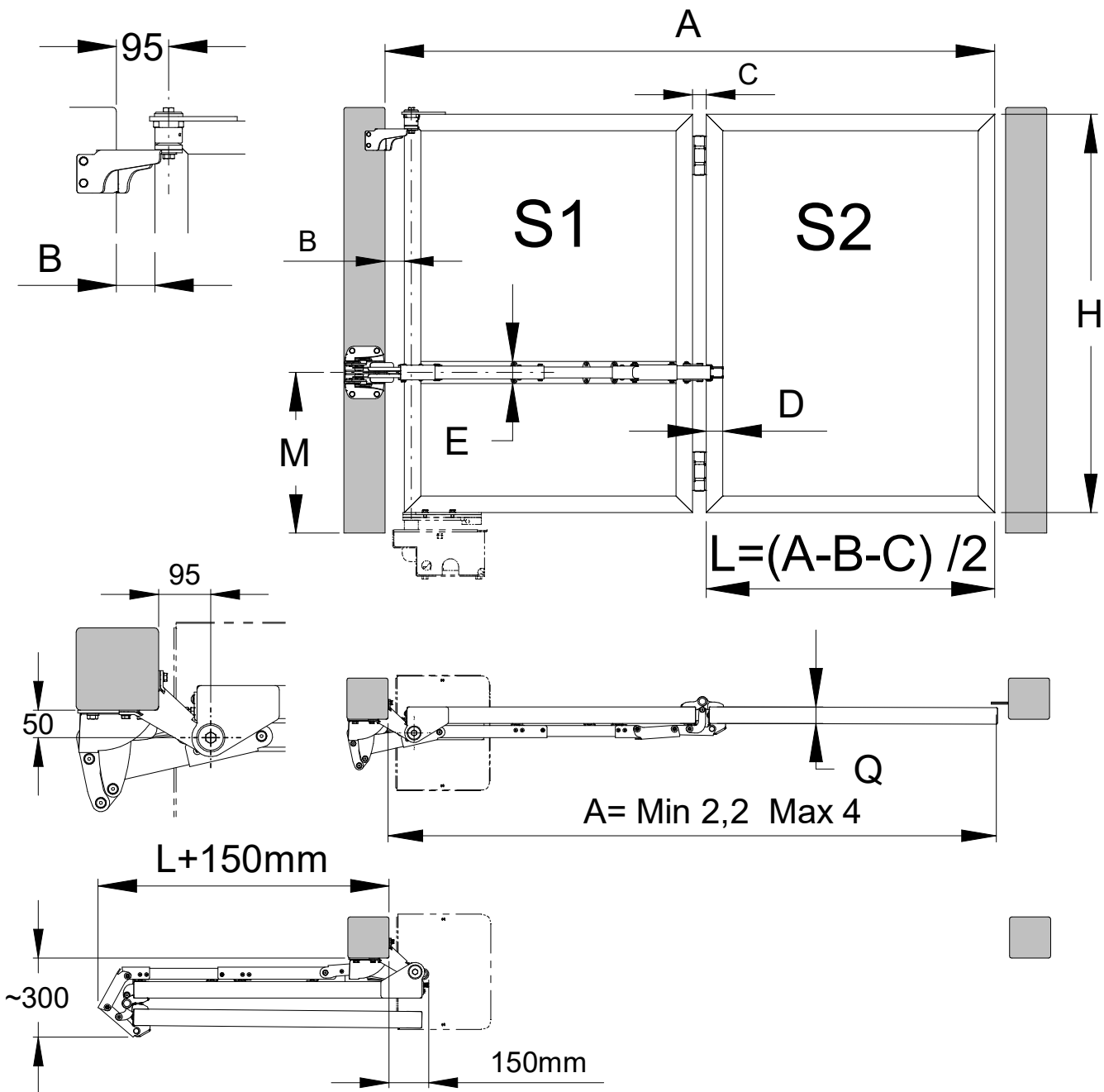
ESEMPIO MISURE FUORI TABELLA
EXAMPLE OF OUT-OF-TABLE MEASUREMENTS

A = 3,6 m
B = 70 mm (da tabella sopra / as per above table)
C = 50 mm da tabella sopra / as per above table
L = (A - B - C) / 2
L = (3,6 - 0,07 - 0,05) / 2
L = 3,48 / 2
L = 1,74 m



PESO MAX S2 IN FUNZIONE DI L
MAX WEIGHT S2 IN RELATION TO L

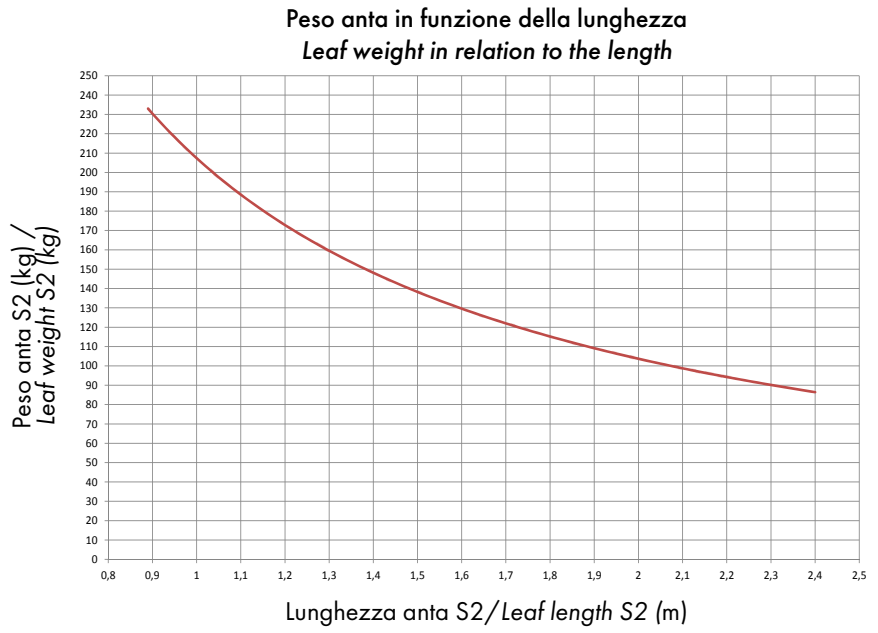
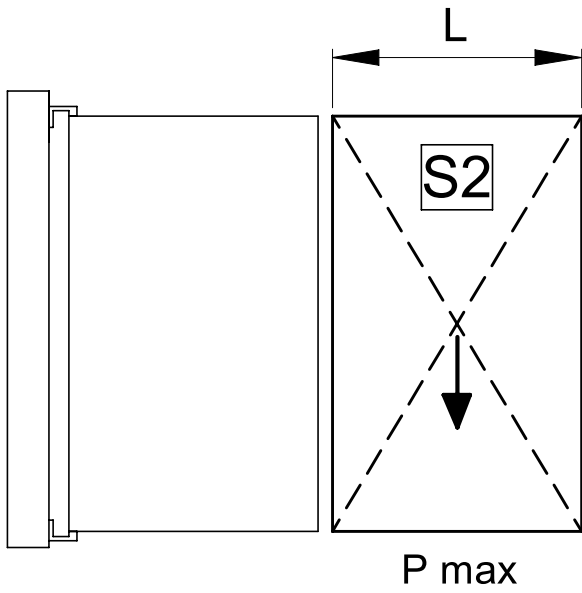

PORTATA CARDINI IN FUNZIONE DI A/H
HINGES WEIGHT CAPACITY IN RELATION TO A/H

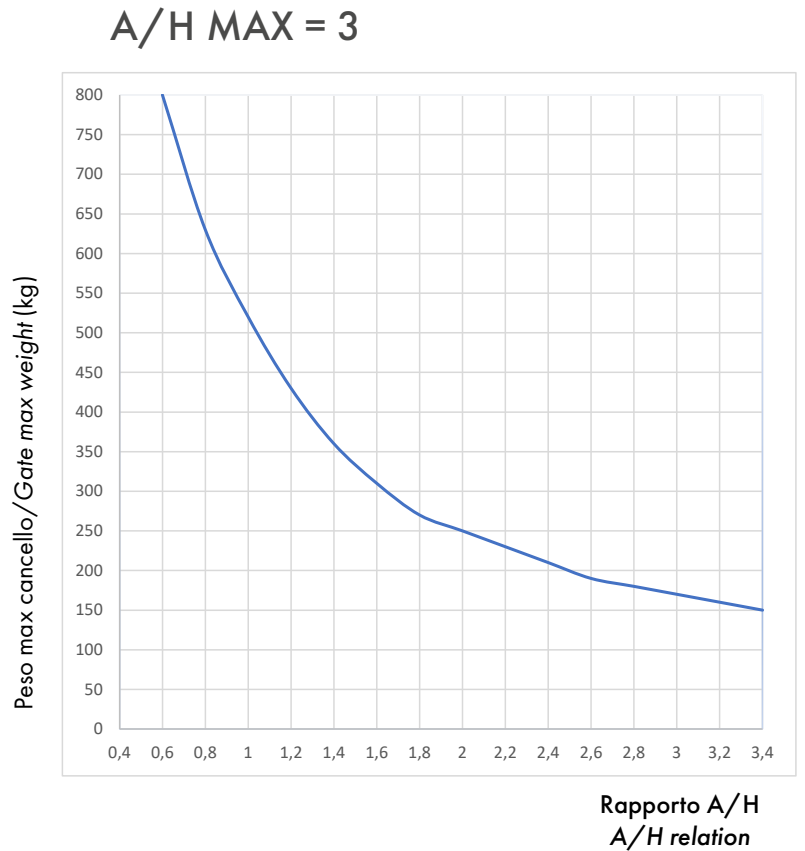
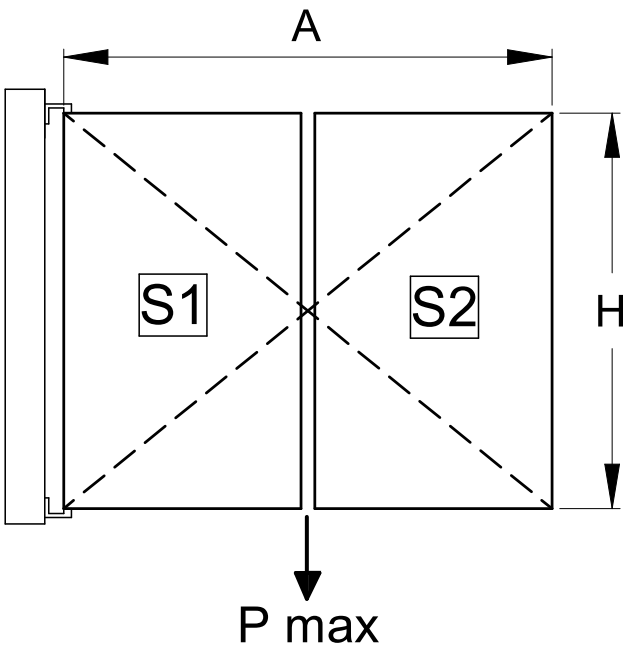

Il punto di incrocio tra peso e rapporto A/H deve posizionarsi sotto alla curva del kit.
The crossing point between weight and A/H relation must be under the curve of the kit.



INFO TECNICHE
TECHNICAL INFO

1. Bi-folding 180° necessita di un motore interrato, con movimento minimo 180°. Velocità di rotazione 180° in min 60 secondi. Prevedere partenze ed arresti lenti e velocità basse per evitare effetti elastici tra le ante e malfunzionamenti.

1. Bi-folding 180° need underground motor, with minimum movement of 180°. Rotation speed of 180° minimum 60 seconds. For motorized gates provide slow starting points, soft stops and suitable speed in order to avoid elastic effects between the leaves and malfunctions.

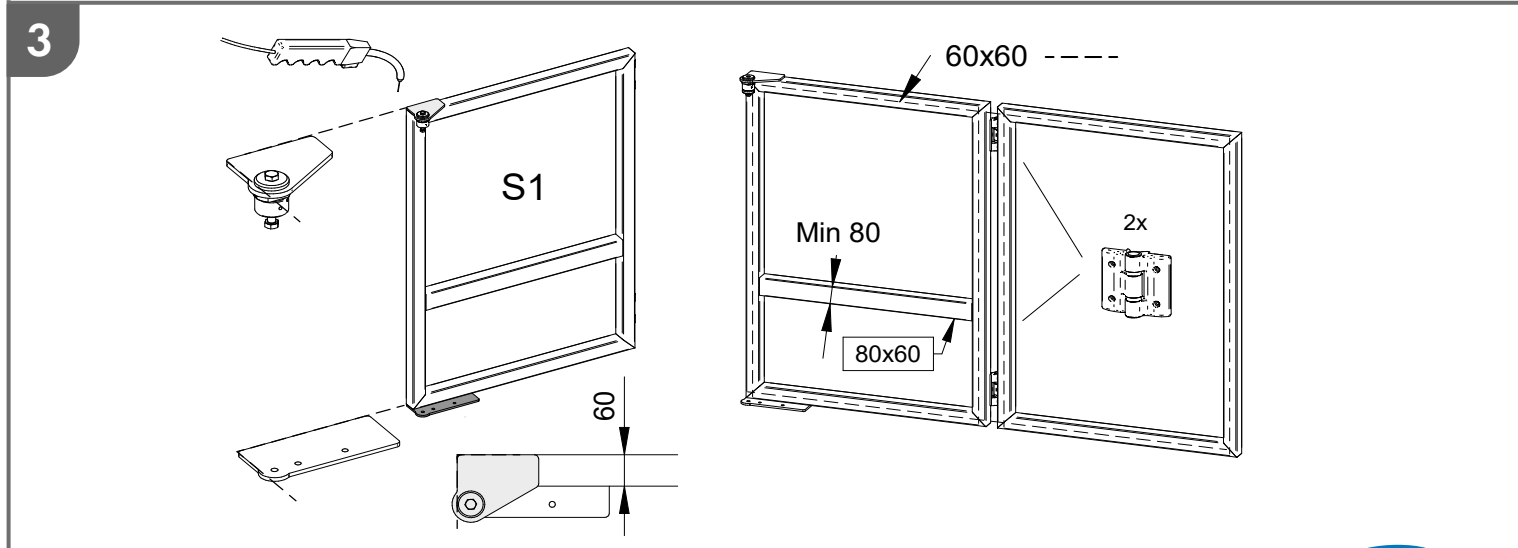
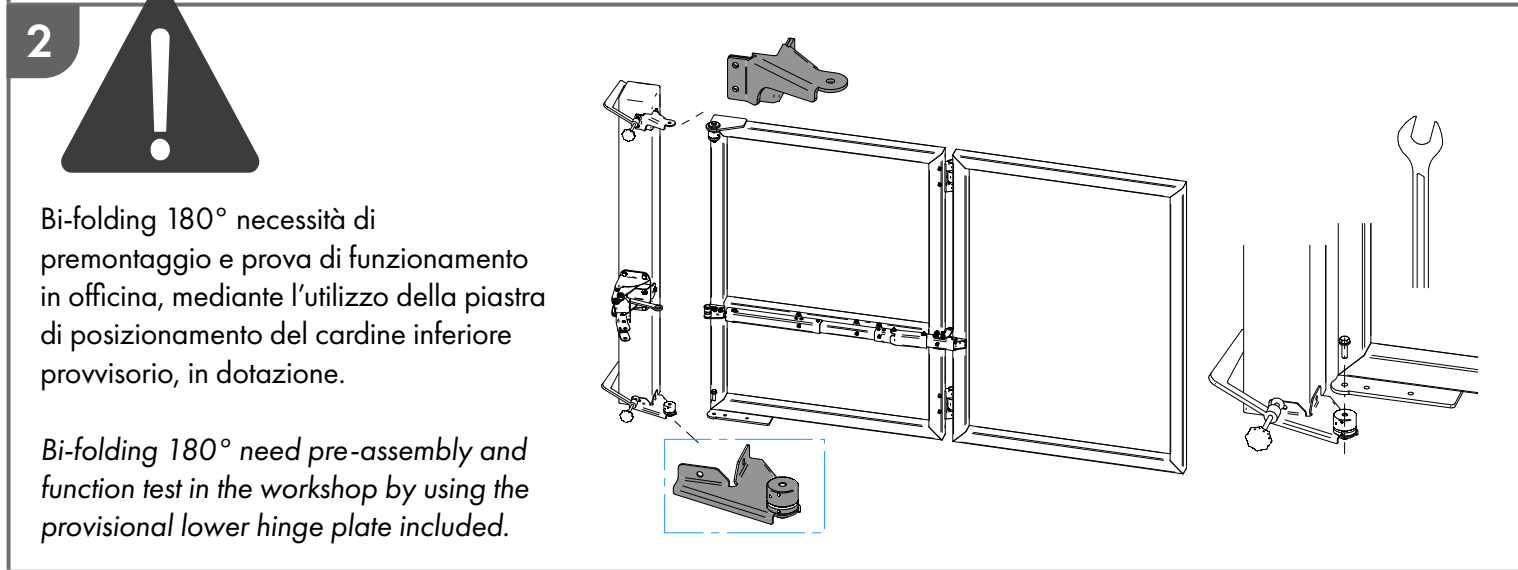
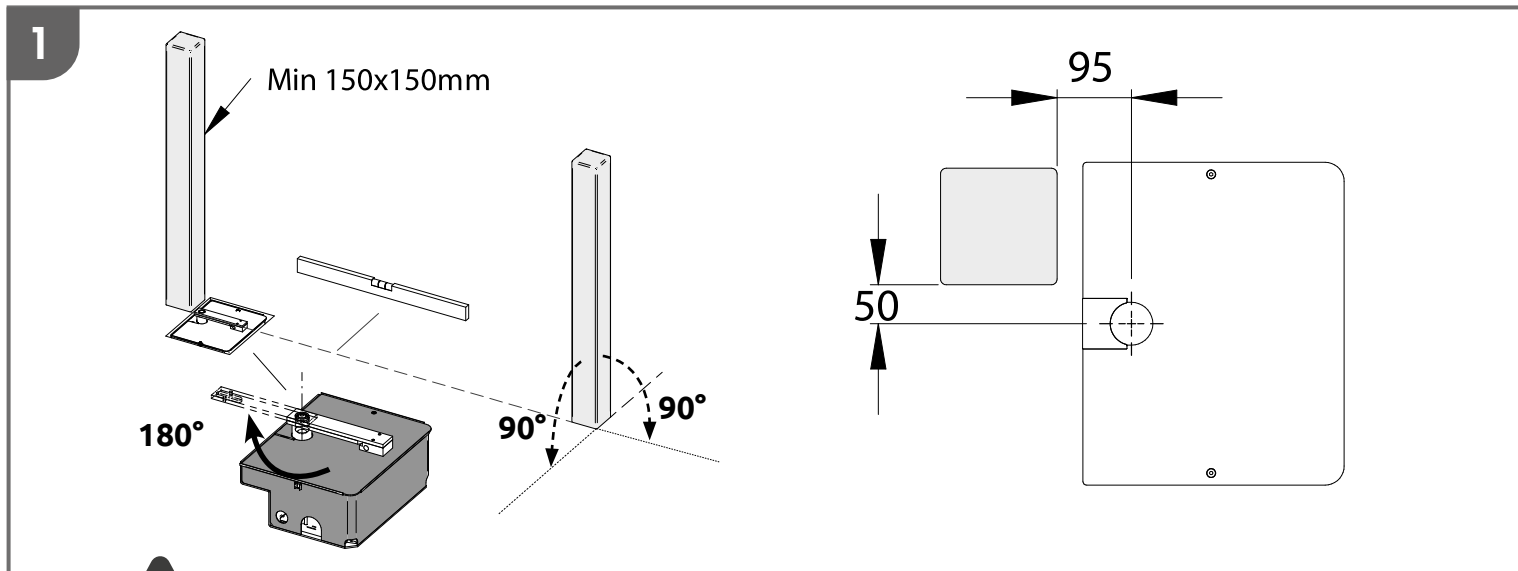



4

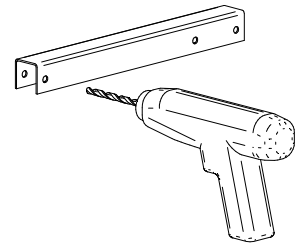
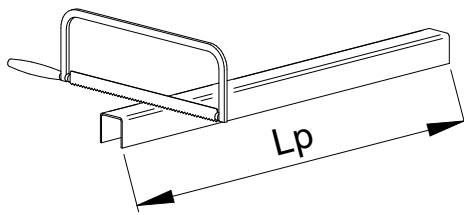

$$L_p = L - 670 \text{ mm}$$

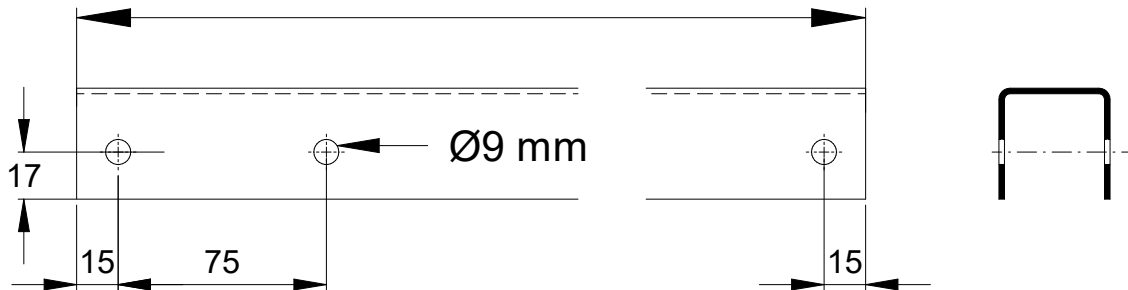

5

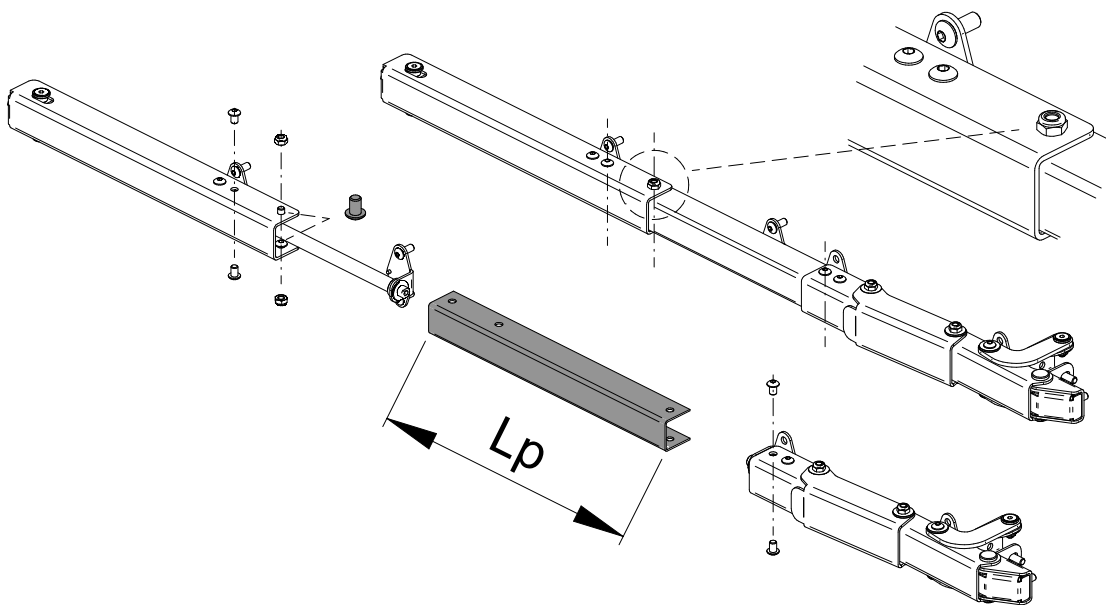

6



Segnare / Mark
Forare / Drill
Filettare / Thread

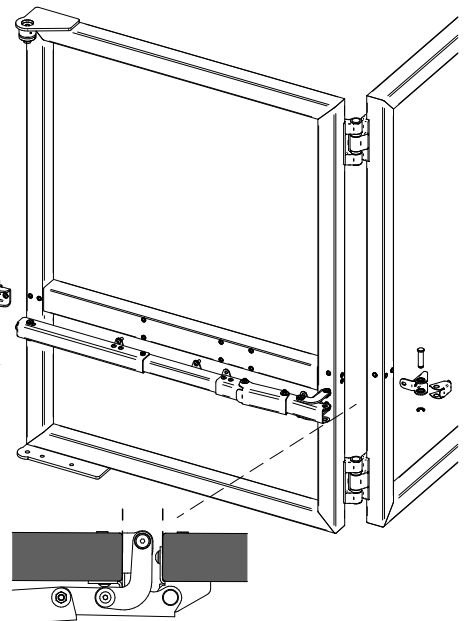
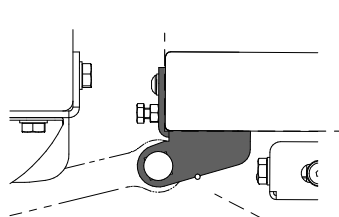

Min. 80

Fori/Holes M8

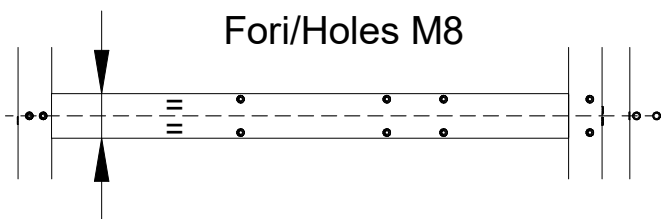



7

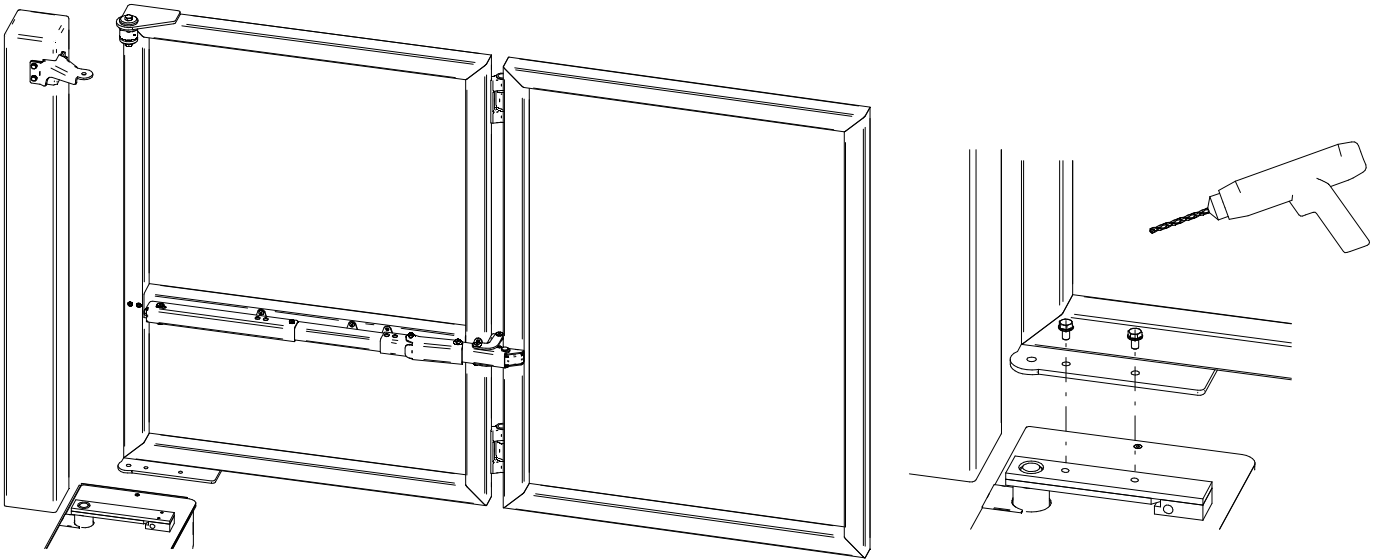

8

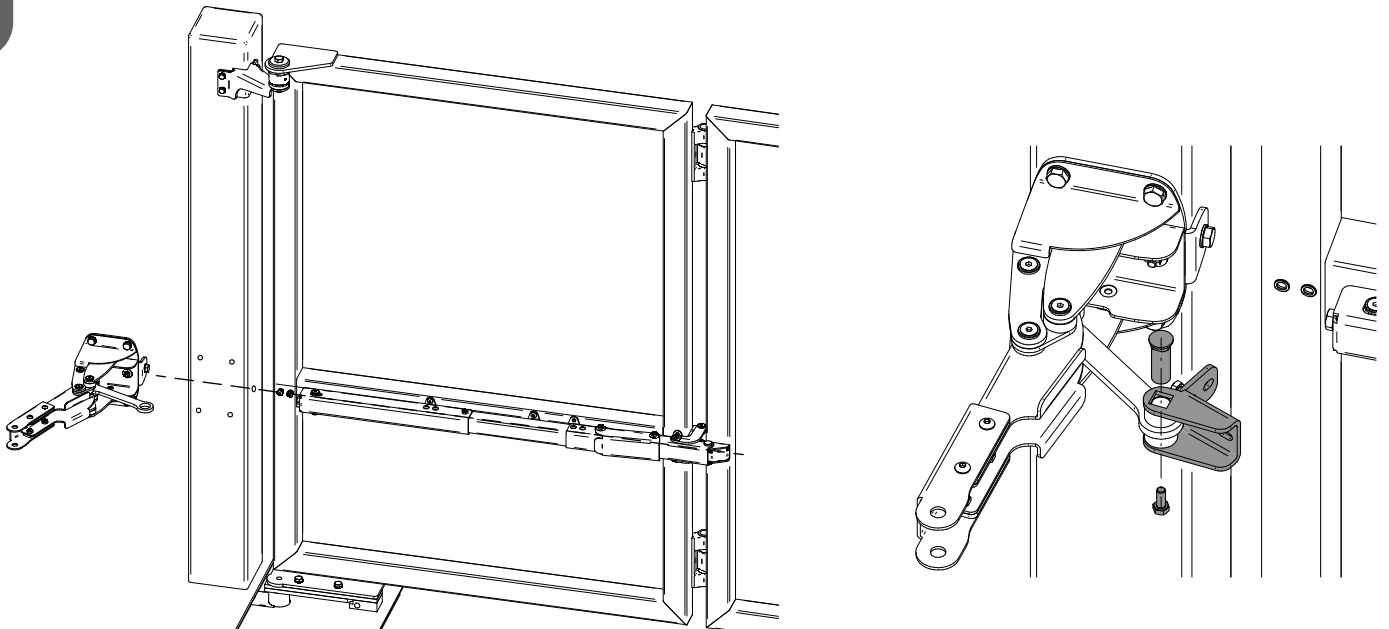

9

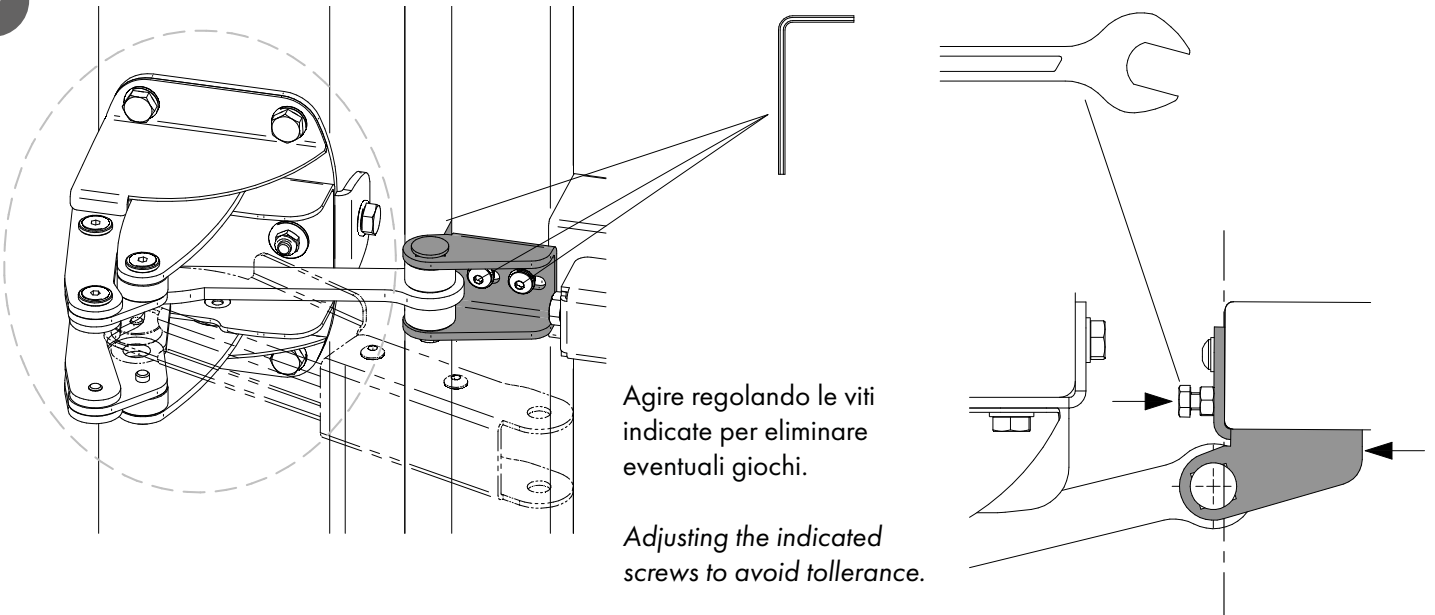



10

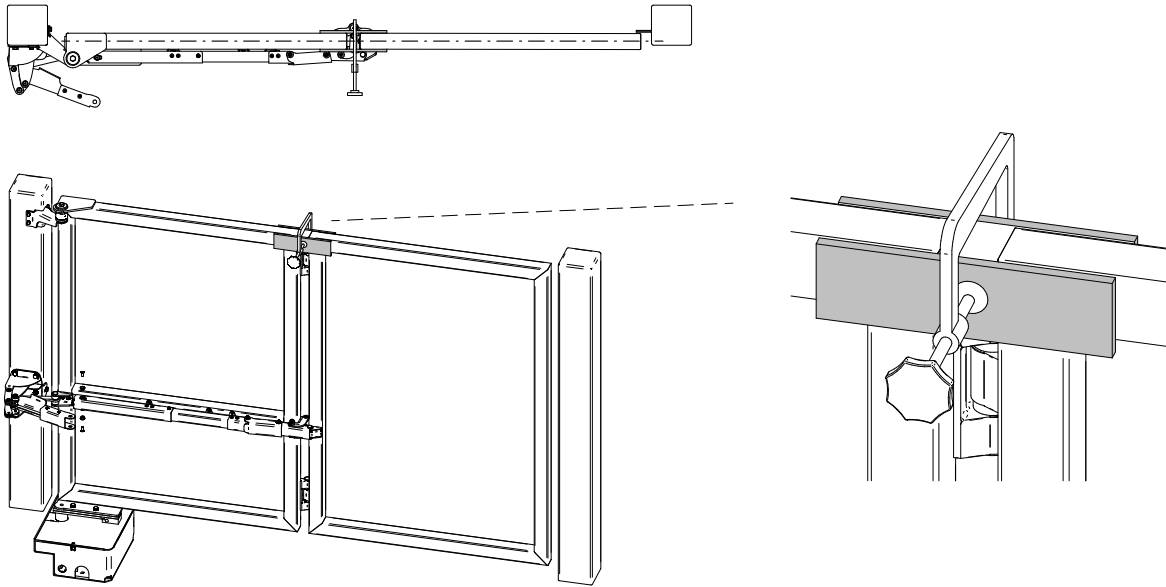

11

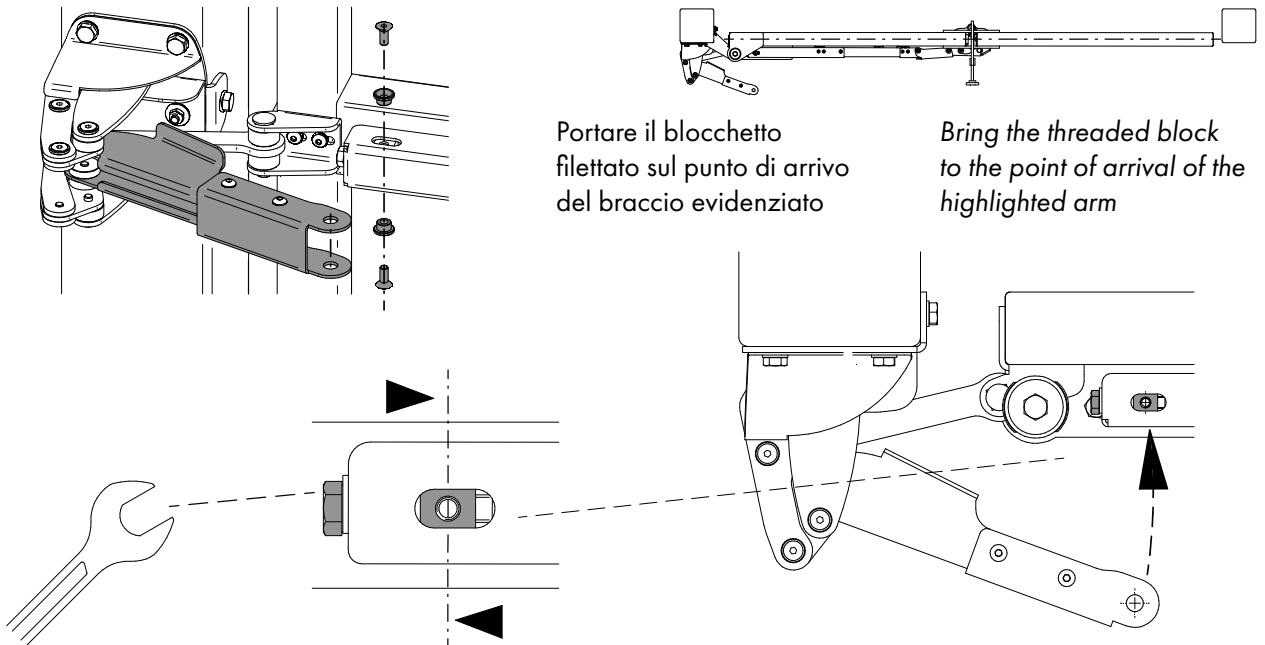

12

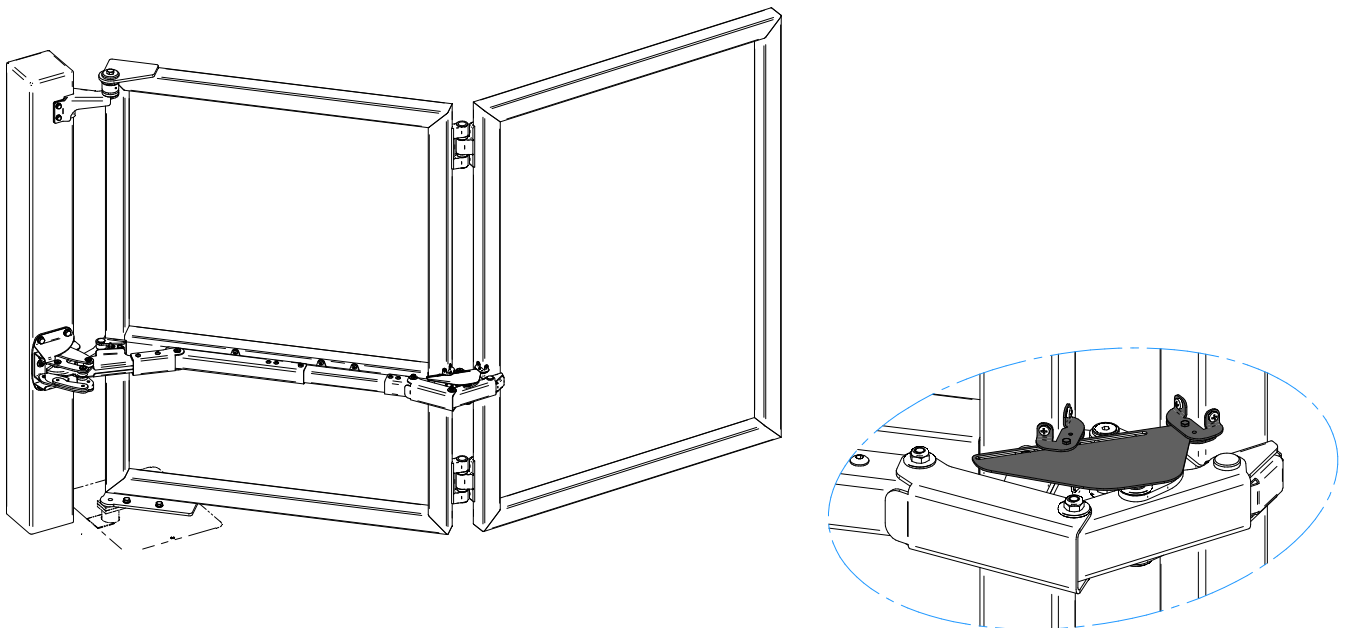



13

R



**CARTER DI SICUREZZA
SAFETY CARTER**

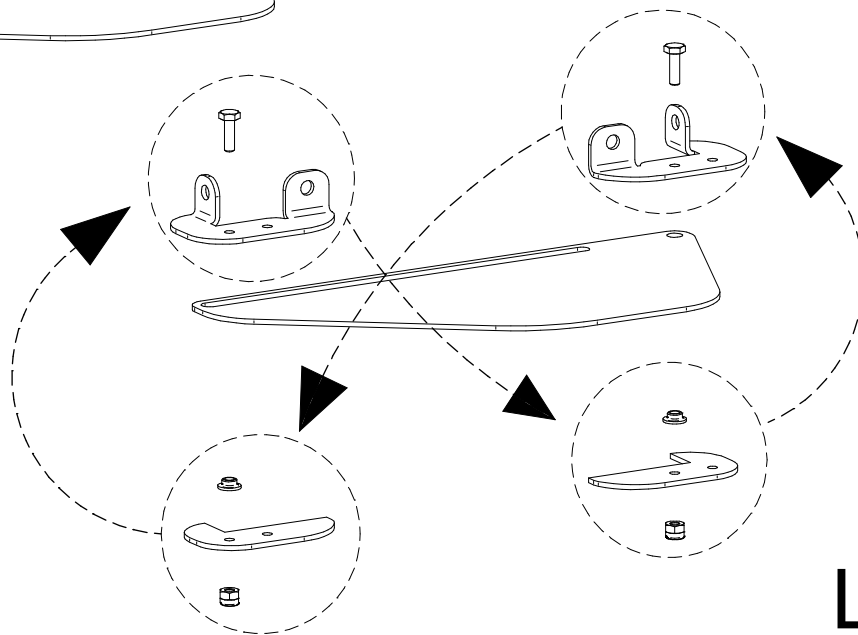
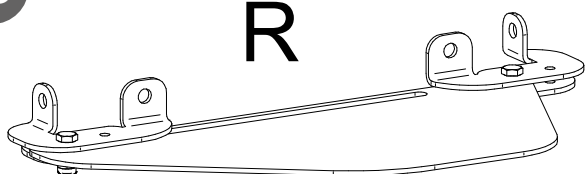

L

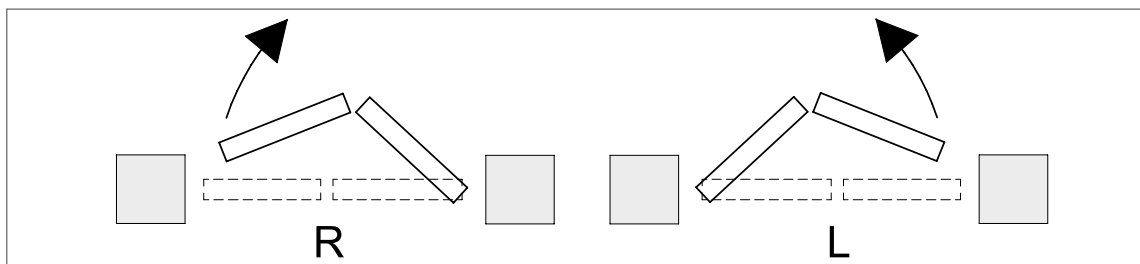



MANUTENZIONE MAINTENANCE

1. Eseguire le verifiche di funzionamento manuale a fine installazione; controllare periodicamente che il sistema sia correttamente funzionante, privo di allentamenti e ben lubrificato (consigliato ogni tre mesi o max 20.000 cicli). Se necessario intervenire serrando le viti e lubrificando.
2. In caso di malfunzionamenti dovuti ad usura o urti accidentali, assicurarsi che tutti i componenti atti al sostegno del cancello ed alla sua movimentazione siano integri, eventualmente procedere alla sostituzione.
3. FAC garantisce il corretto funzionamento del sistema esclusivamente con l'utilizzo di ricambi originali.

Attenzione: FAC non si assume alcuna responsabilità in caso di errata installazione od utilizzo di accessori/componenti/ricambi non originali e non idonei all'opera specifica.

Gli accessori compresi nei kit e l'installazione proposta fanno riferimento ad un esempio standard. Una installazione non conforme alla procedura illustrata e/o l'omissione delle corrette manutenzione potrebbero causare malfunzionamenti, compromettendo la sicurezza di persone e cose adiacenti. Verificare che gli accessori siano idonei all'opera specifica e dotarla dei necessari dispositivi di sicurezza previsti dalle normative vigenti.

Per ulteriori informazioni scrivici a : info@fac srl.com

1. Perform all functioning inspections manually at the end of the installation; periodically check that the system is functioning, that it is well lubricated and does not have any loosening (we suggest a full examination every 3 months or maximum 20.000 cycles).
2. In case of malfunctions due to wear or accidental impacts, make sure that all components apt to support the gate and its movement are intact. If necessary, proceed with substitution.
3. FAC ensures the system correct functioning only using original spare parts.

Attention: FAC does not assume any responsibility in the event of incorrect installation or use of non-original and unsuitable accessories/spare parts.

The kit included accessories and the proposed installation make reference to a standard example. An installation not in accordance with the illustrated procedure and the omission of the correct maintenance might compromise nearby things and people's security. Make sure that all accessories suit the specific work and make sure to use the necessary safety devices provided by current regulations.

For more information: info@fac srl.com



KIT BI-FOLDING 180° BI-FOLDING 180° KIT

Kit d'accessoires en acier galvanisé, avec charnières en aluminium, pour la construction d'un portail Bi-folding. Le système 180° reprend toutes les caractéristiques du système Bi-folding, en étant équipé d'un bras spécial et de charnières spéciales qui lui permettent de se déplacer jusqu'à 180°. Les charnières et les gonds ont été spécialement conçus et garantissent une construction exceptionnellement solide, associée à un mouvement précis, sans qu'il soit nécessaire d'utiliser des rails au sol.

En outre, les portes pliantes permettent de minimiser l'espace nécessaire à l'ouverture et à la fermeture. Ce système est parfait pour les applications résidentielles et/ou commerciales, tout en maintenant l'accent sur la protection et la sécurité.

Zubehör-Kit aus verzinktem Stahl, mit Aluminiumscharnieren für ein Bi-folding-Tor mit Dreh-Falt-Flügeln. Das 180°-System hat sich alle Merkmale des Bi-folding-Systems zu eigen gemacht mit einem entsprechenden Arm und speziellen Torbändern, die die Bewegung in einem Winkel bis 180° ermöglichen. Die Torbänder und Scharnieren sind spezifisch gestaltet und garantieren eine außerordentlich solide Anlage sowie eine präzise Bewegung ohne Bodenschienen.

Zudem reduzieren die faltbaren Türen den Platzbedarf beim Öffnen und Schließen auf ein Mindestmaß. Dieses System ist ideal für Wohn- und Gewerbeanwendungen. Stets liegt ein besonderes Augenmerk auf den Anforderungen an Schutz und Sicherheit.



KC7201.160

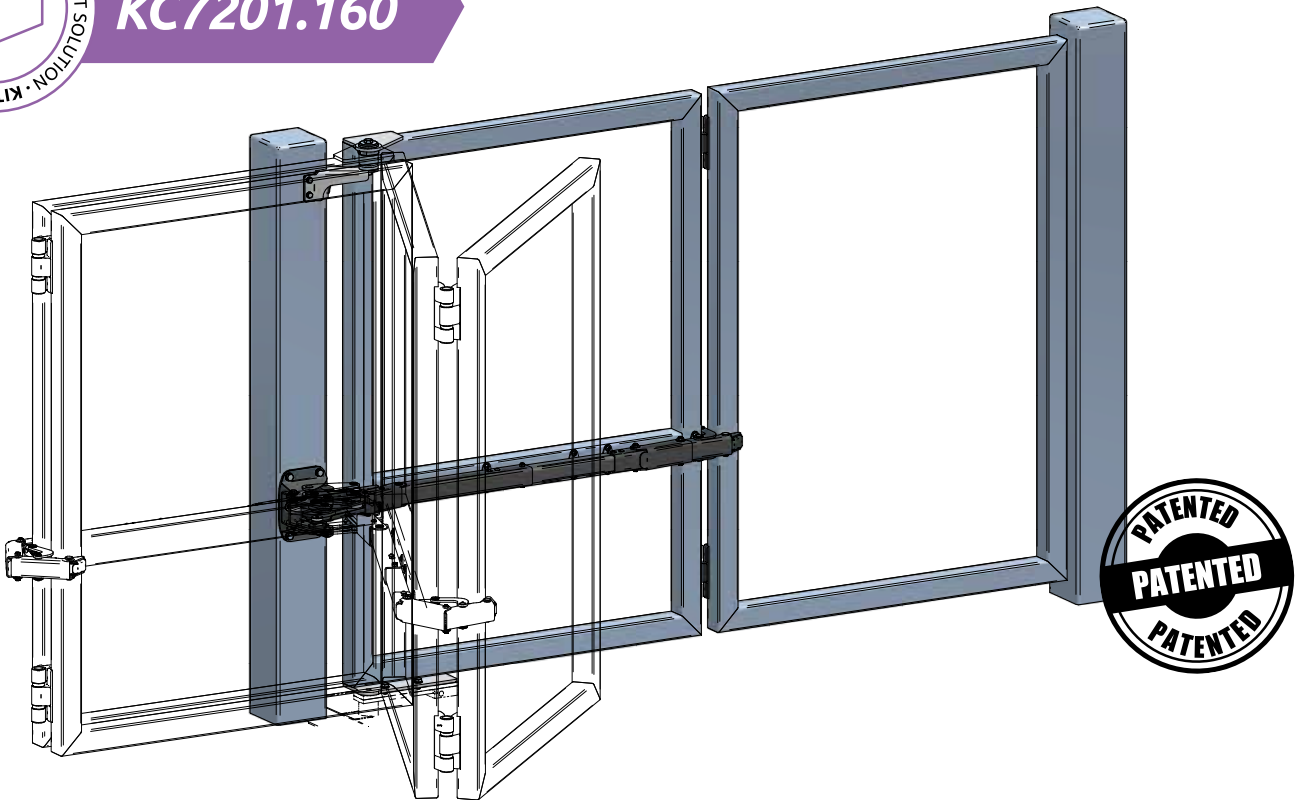

1 kit

Pour Seule Porte
für Einzeltor

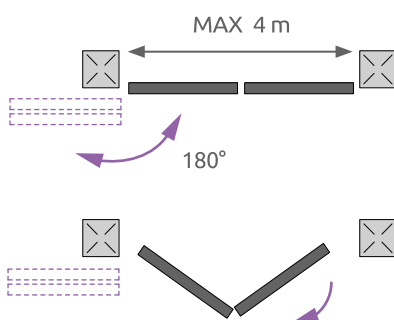



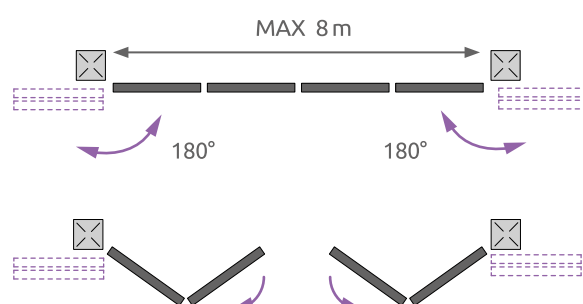

2 kit

Pour Double Porte
für Doppeltor





LISTE DE COMPOSANTS
KOMPONENTEN

<p>x1</p> 	<p>x1</p> 	<p>x1</p> 
<p>VC7201.060</p>	<p>VC7202.060</p>	<p>VC7203.060</p>
<p>x1</p> 	<p>x1</p> 	<p>x2</p> 
<p>VC7205.060</p>	<p>VC7204.060</p>	<p>VL4500</p>
<p>x1</p> 	<p>x1</p> 	<p>x1</p>  <p>* pour prémontage uniquement, voir les instructions à suivre * nur für die provisorische Montage, siehe die folgende Anleitung.</p>
<p>VC7105.060</p>	<p>VA5401</p>	<p>Cardine inferiore/bottom hinge</p>

ARTICLE CONNEXES
VERWANDTE ARTIKEL



VC9101
VC9111



VC5101
VC5102
VC5103



Connectez-vous sur notre site pour voir les différents types et mesures disponibles
Welche Arten und Maße erhältlich sind, erfahren Sie auf unserer Website

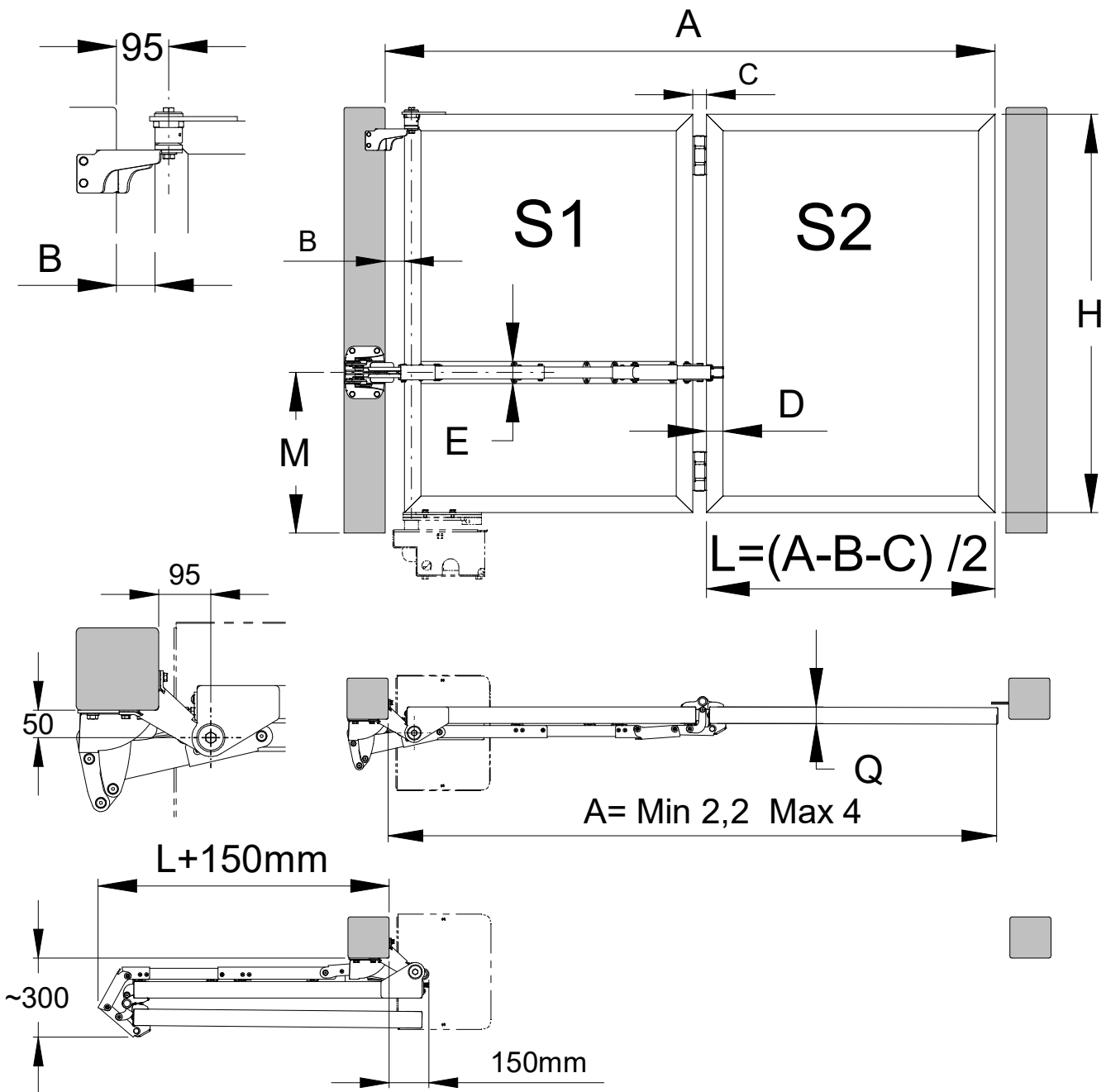

**TABLEAU DES DIMENSIONS
MASSTABELLE**

A min-max (m)	B min (mm)	C (mm)	D min (mm)	E min (mm)	M max (mm)	Q (mm)	A/H max	H max (m)
2,2 - 4	70	50	60	80	800	60	3	2,5

OUVERTURE A (m) max ÖFFNUNG A (m)	L (m) con/mit B=0,07 m	Poids Maximum S2 (kg) max. Gewicht S2 (kg)
2,2	~ 1,04	125
2,6	~ 1,24	125
3	~ 1,44	125
3,5	~ 1,69	120
4	~ 1,94	105

Données calculées avec A/H = 2
Data calculated with A/H = 2

**EXEMPLE AVEC MESURES HORS TABLEAU
BEISPIEL NICHT IN TABELLE VERZEICHNETE MASSE**

A = 3,6 m
B = 70 mm (voir tableau / gemäß der obigen Tabelle)
C = 50 mm voir tableau / gemäß der obigen Tabelle
L = (A - B - C) / 2
L = (3,6 - 0,07 - 0,05) / 2
L = 3,48 / 2
L = 1,74 m



POIDS MAXIMUM DU VANTAIL S2 EN FONCTION DE LA LONGUEUR L
MAX. GEWICHT S2 IN ABHÄNGIGKEIT VON L

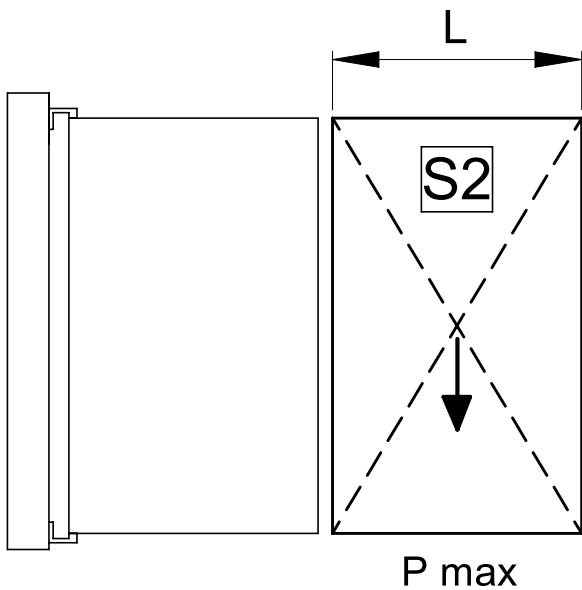

Poids Maximum du vantail en fonction de la longueur
Flügelgewicht in Abhängigkeit von der Länge

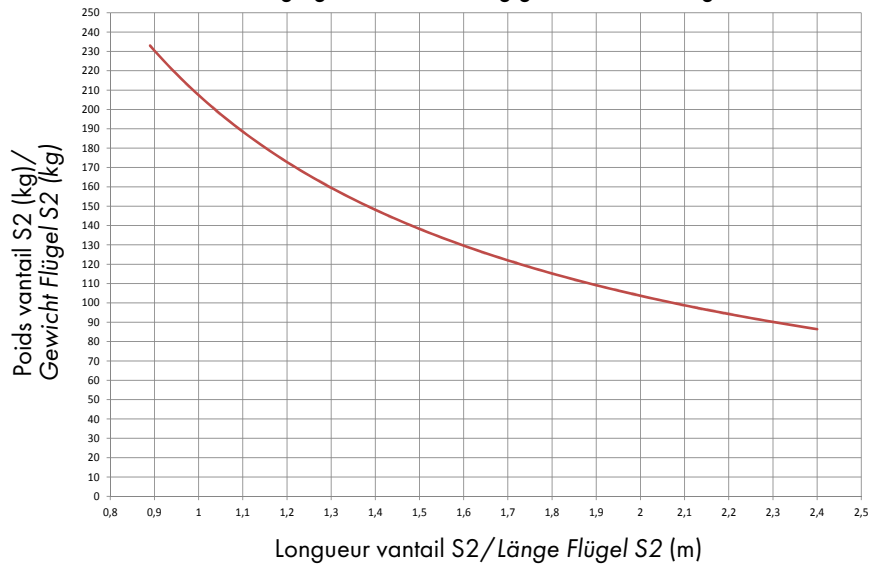

CHARGE GONDS EN FONCTION DE A/H
TRAGFÄHIGKEIT TORBÄNDER IN
ABHÄNGIGKEIT VON A/H

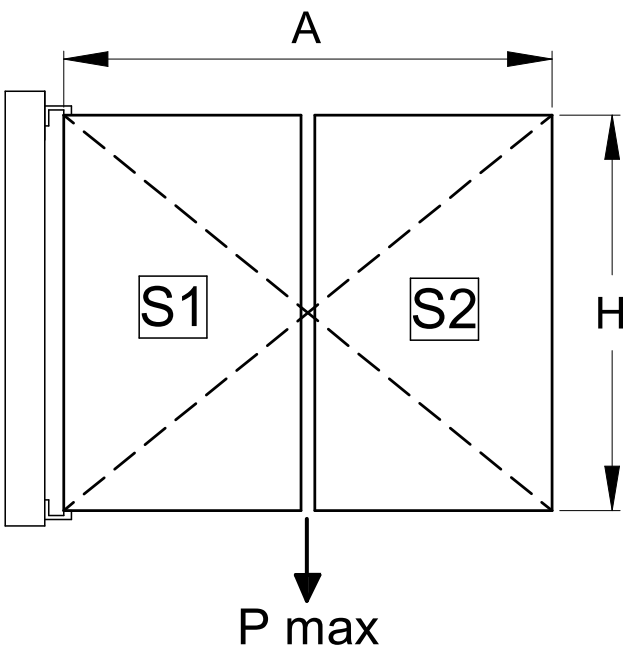

$A/H \text{ MAX} = 3$

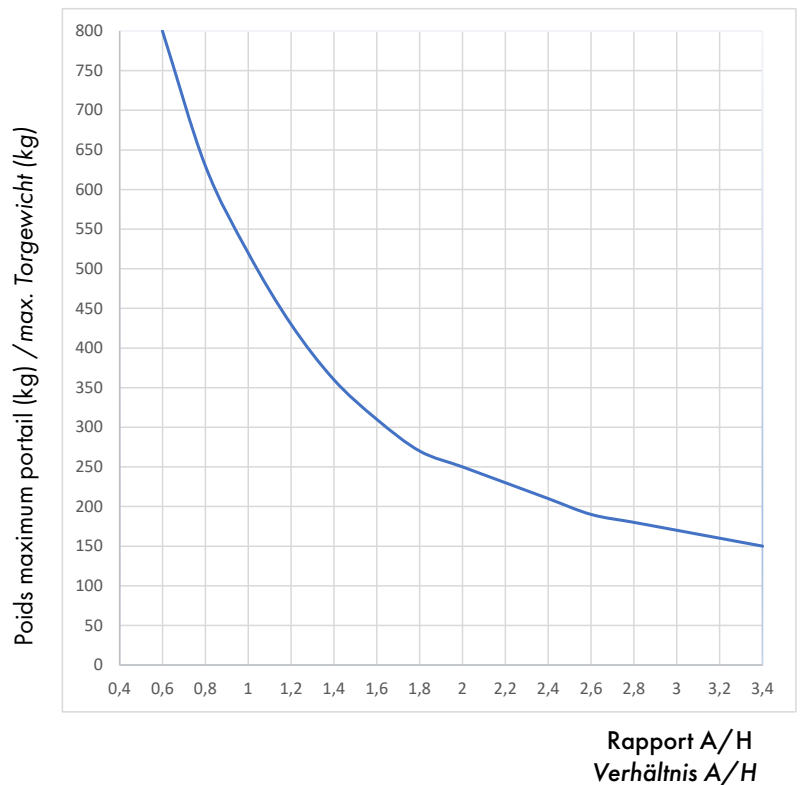

Le point d'intersection entre le poids et le rapport A/H doit être sous la courbe du Kit.
Der Schnittpunkt der Grafiken Gewicht und Verhältnis A/H muss sich unterhalb der Kurve.



INFO TECHNIQUE
TECHNISCHE INFORMATIONEN

1. Bi-folding à 180° nécessite un moteur enterré, mouvement minimum de 180°. Vitesse de rotation de 180° en 60 secondes minimum. Prévoir des démarrages et des arrêts lents et des vitesses faibles pour éviter les effets de ressort entre les vantaux et les dysfonctionnements.

1. Bi-folding 180° benötigt einen Unterflur-Motor mit einem Mindestbewegungswinkel von 180°. Drehgeschwindigkeit 180° in mindestens 60 Sekunden. Vorzusehen sind ein langsames Anlaufen und Anhalten sowie geringe Geschwindigkeiten. So werden elastische Effekte zwischen den Flügeln sowie Fehlfunktionen vermieden.

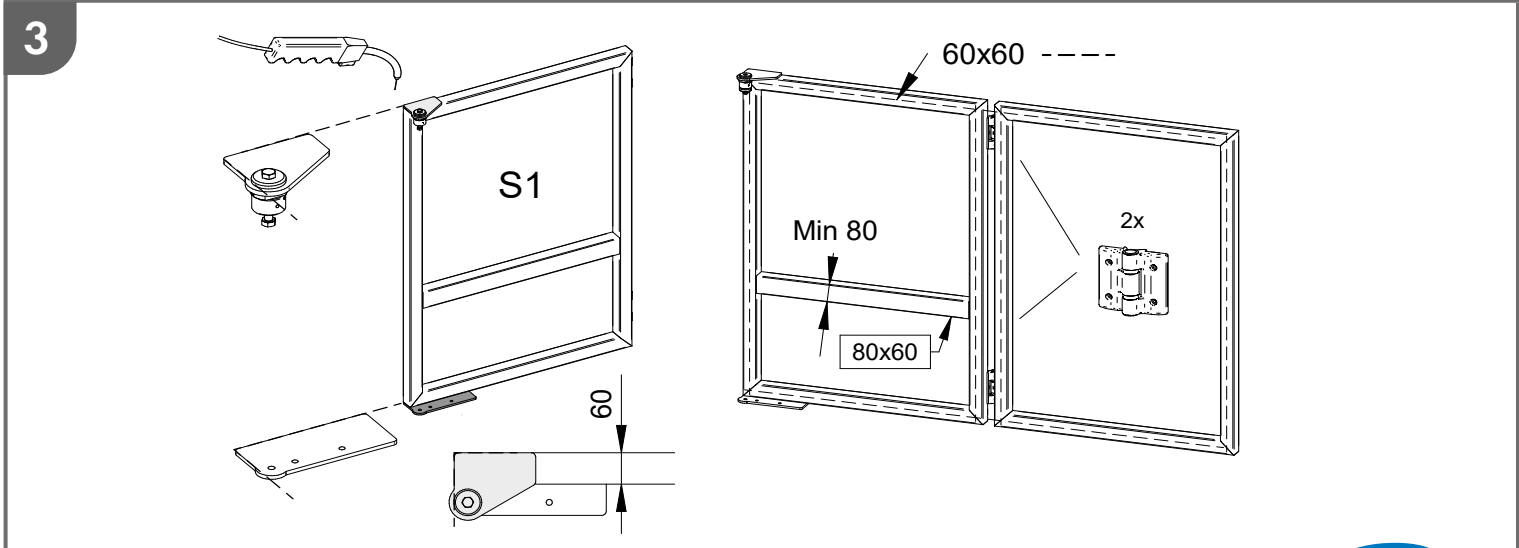
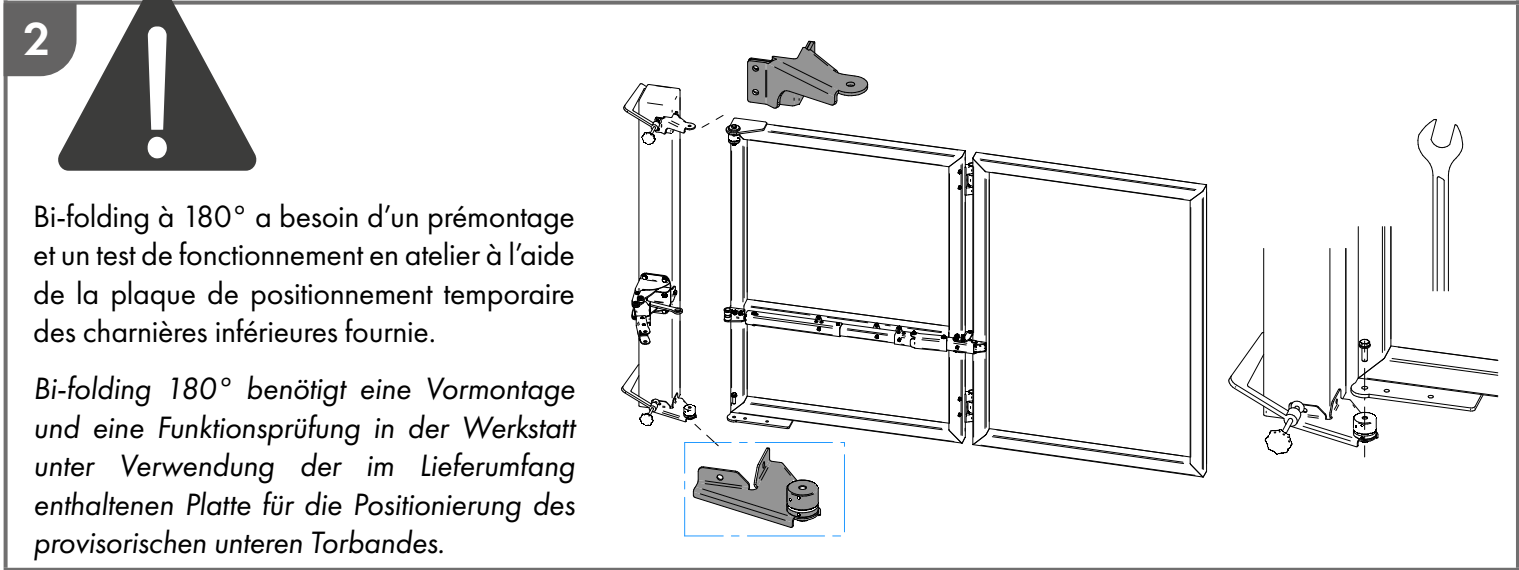
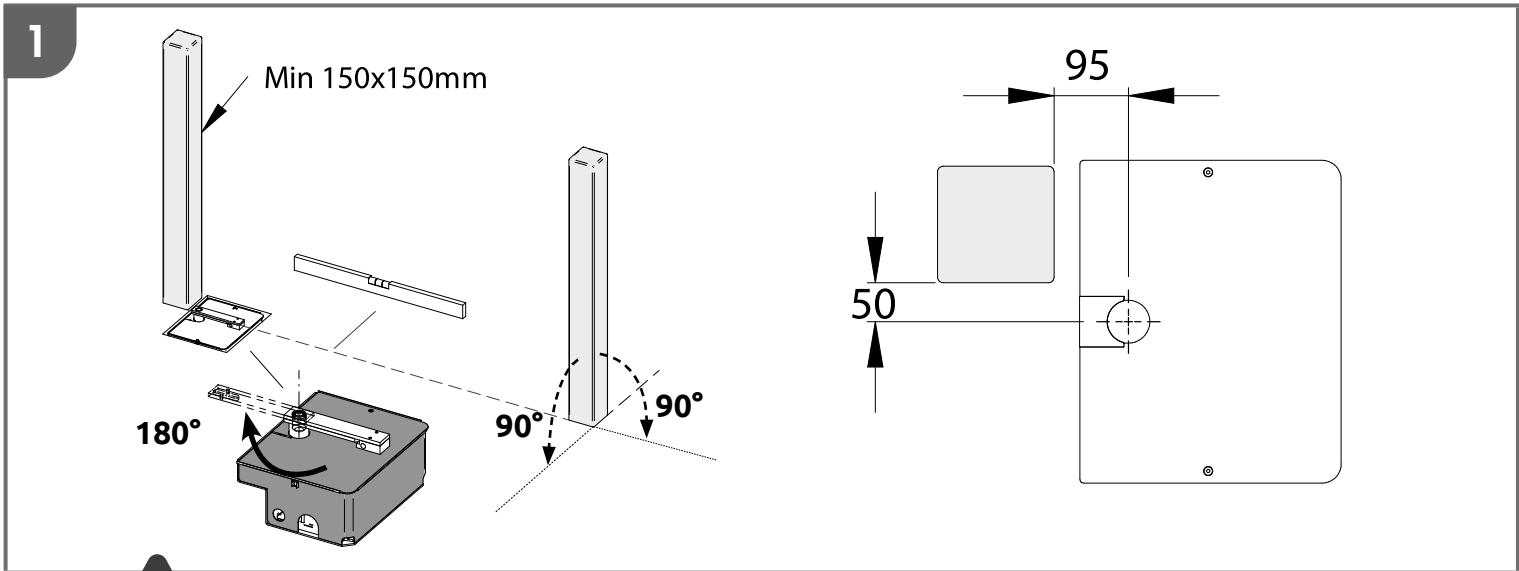



4

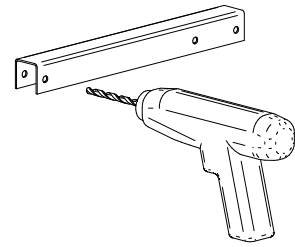
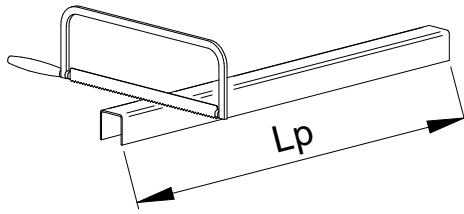

$$L_p = L - 670 \text{ mm}$$

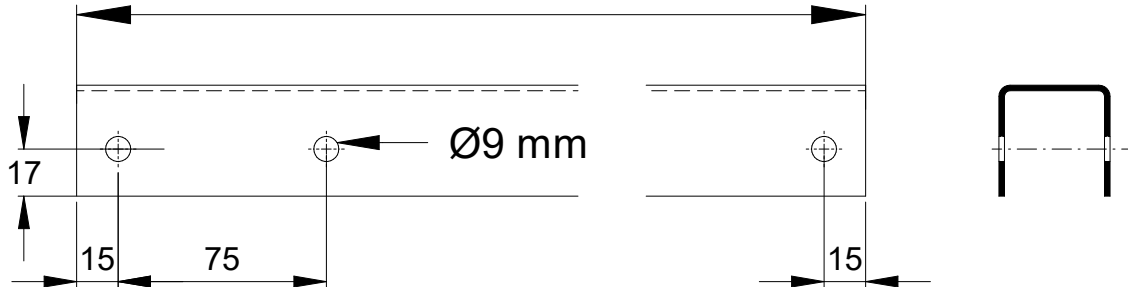

5

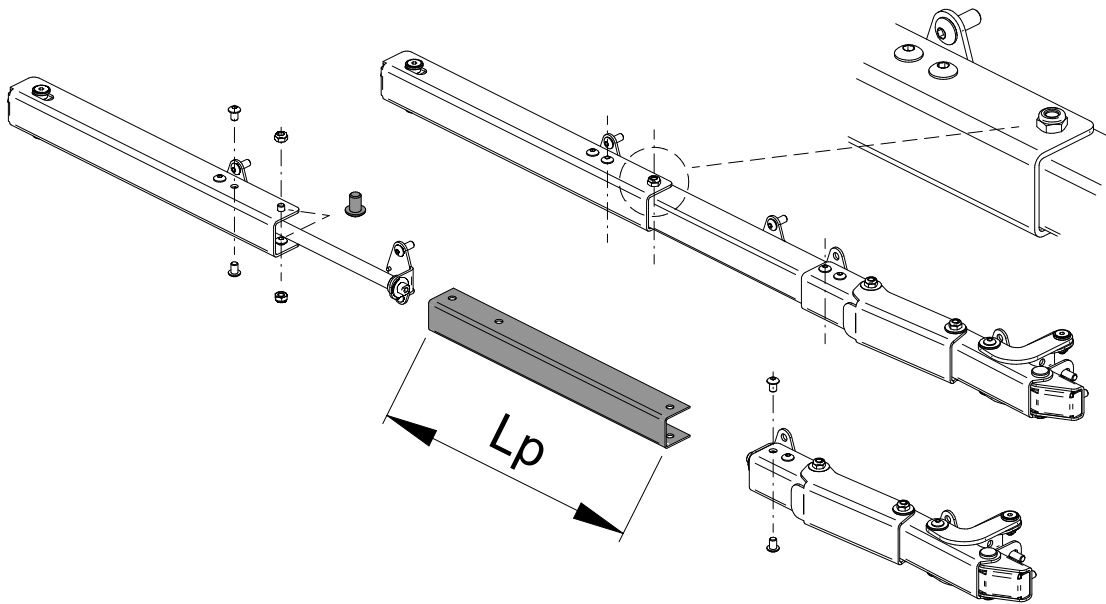

6



Marquer / Markieren
Percer / Bohren
Fileter / Gewindeschneiden

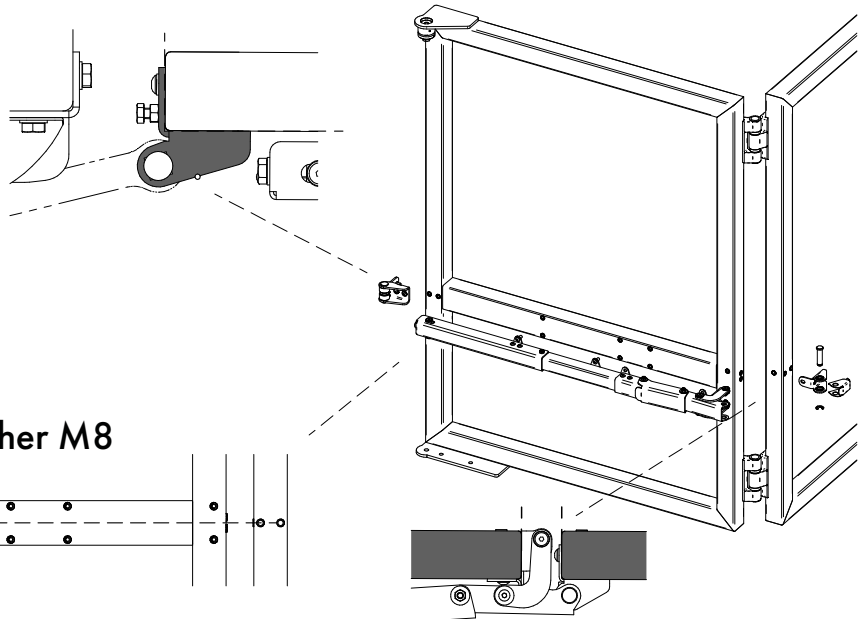

Min. 80

Trous/Löcher M8

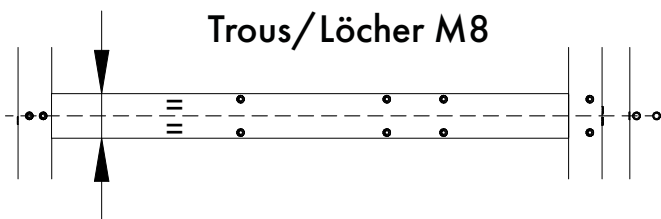



7

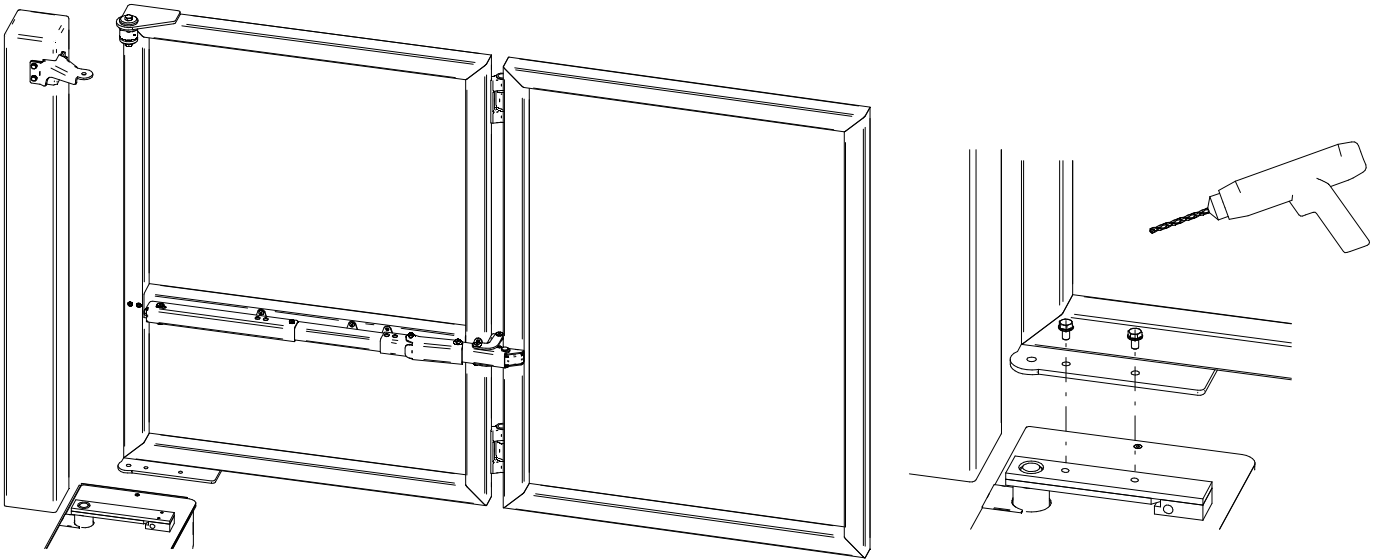

8

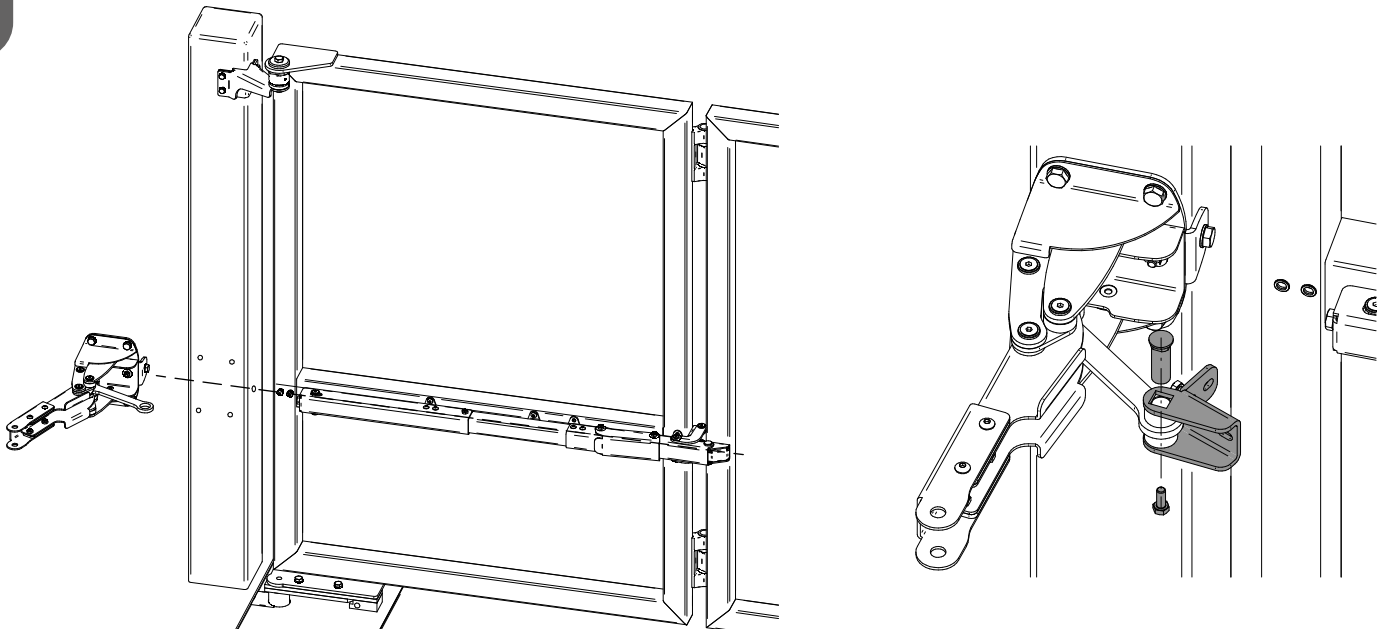

9

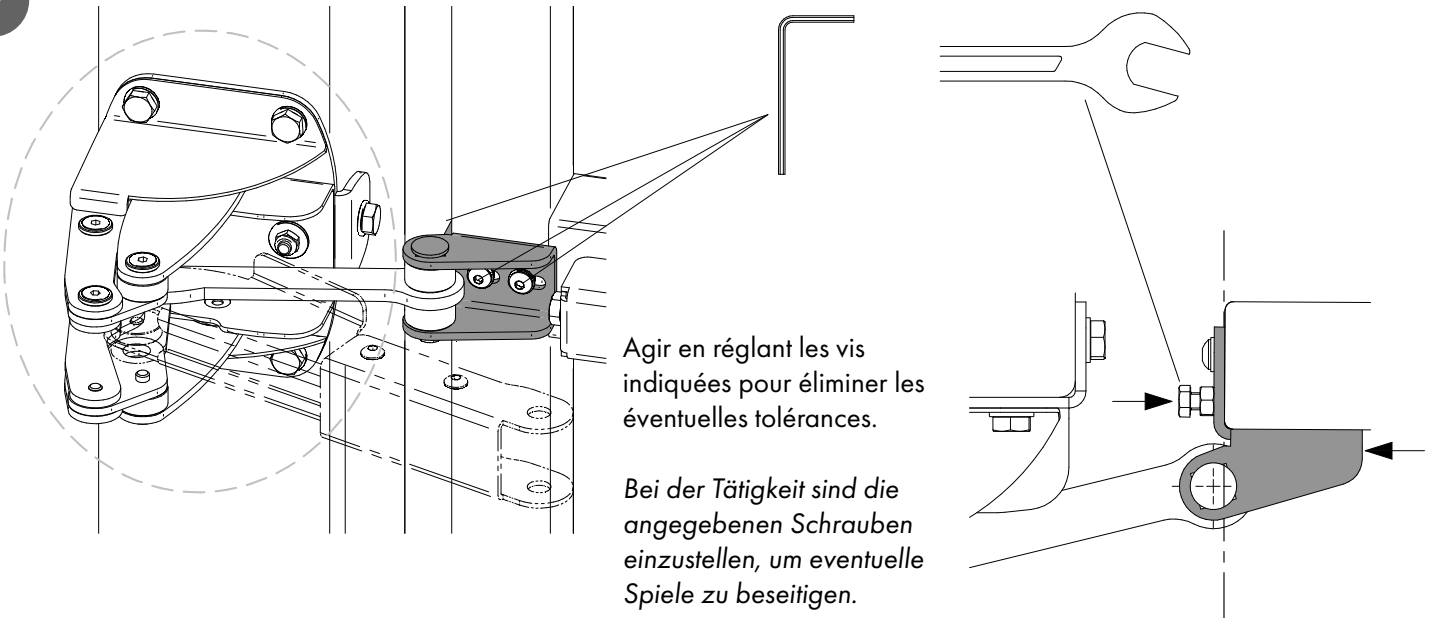



10

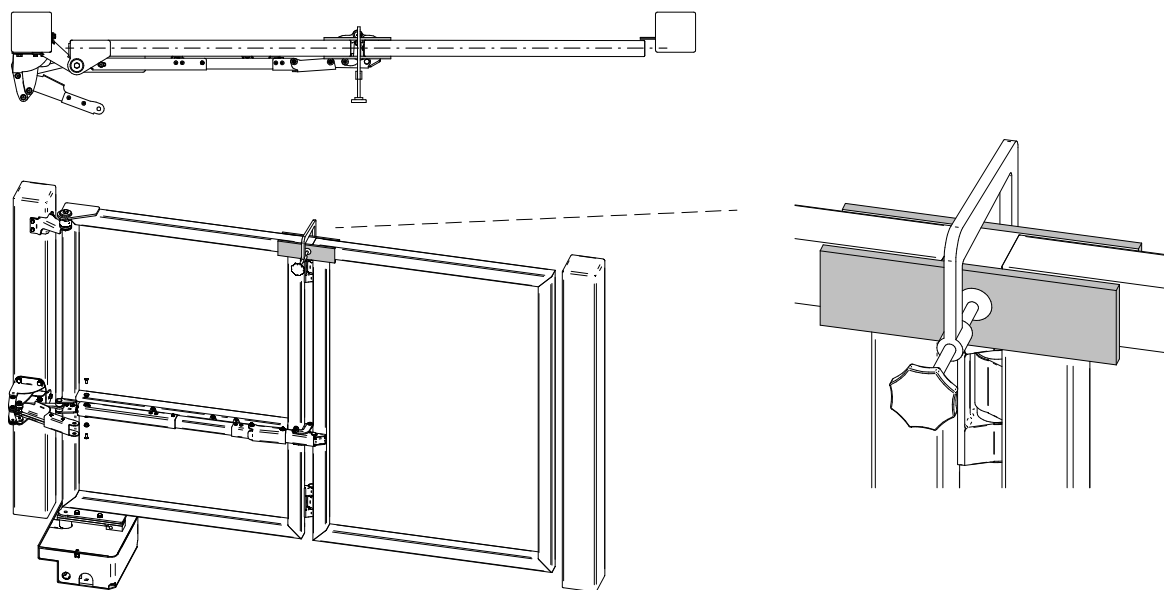

11

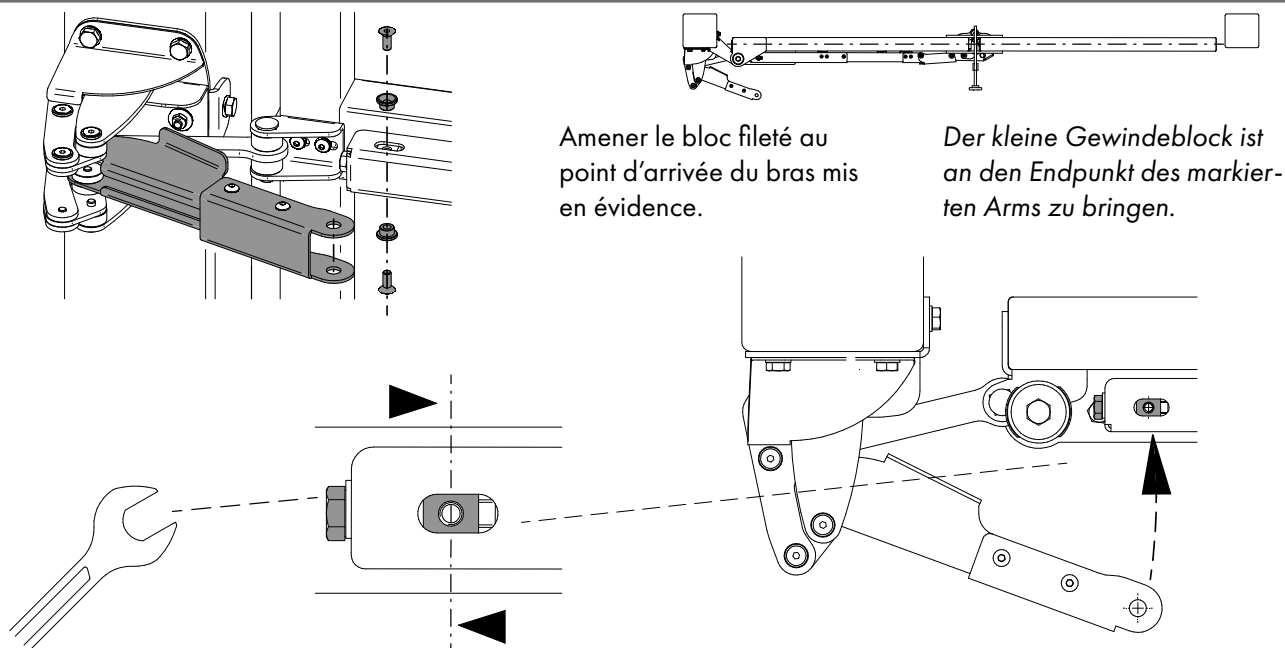

12

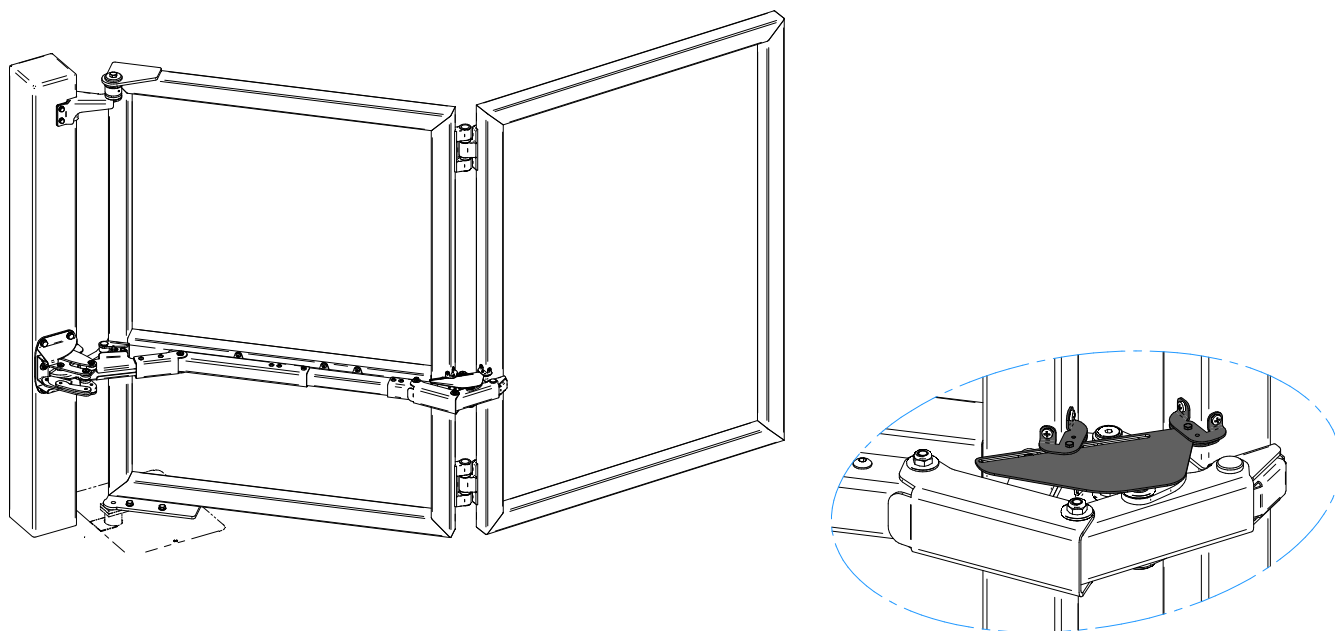



13

R



**CARTER DE PROTECTION
SICHERHEITSGEHÄUSE**

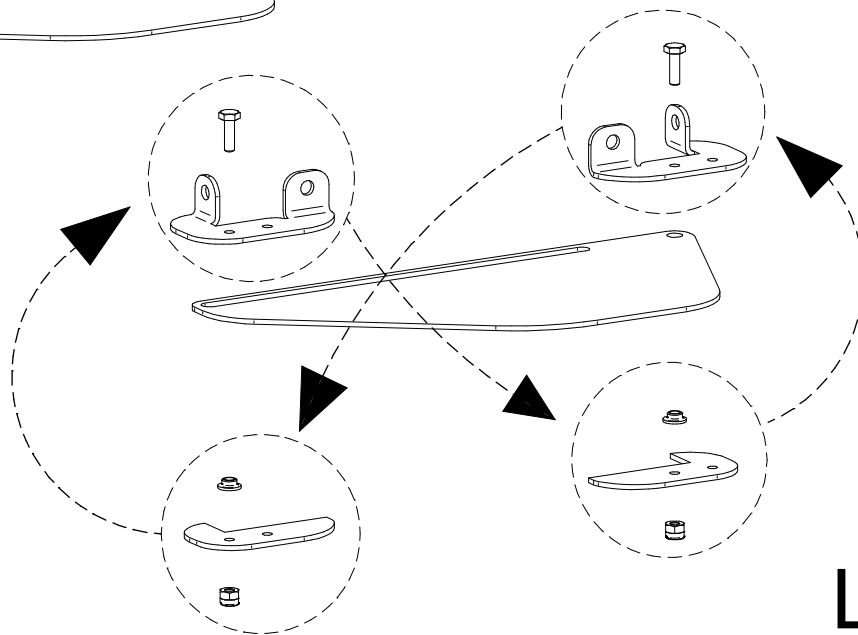
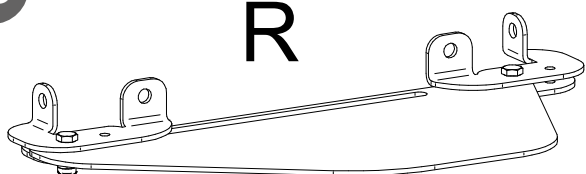

L

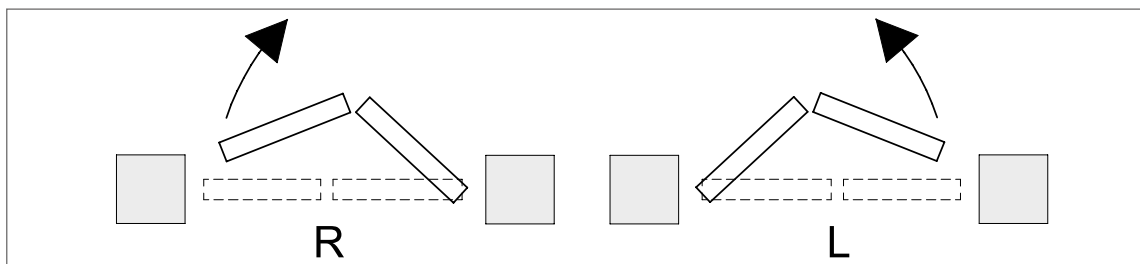



ENTRETIEN WARTUNG

1. Une fois le montage terminé et après avoir exécuté quelques opérations d'ouverture et fermeture, s'assurer qu'il n'y a pas de pièces desserrées ; dans tous les cas, contrôler périodiquement qu'il n'y a pas de desserrements provoqués par des vibrations, chocs ou autres. Garder toujours lubrifié les pivots aux points de jonctions tous les trois mois et max tous les 8000 cycles. Si nécessaire il faut intervenir en serrant les vis et en lubrifiant (voir image 15)
2. En cas de chocs provoqués par des véhicules ou par d'autres causes, s'assurer que les pièces du portail n'ont pas été endommagées. En cas de pièce abîmée, remplacer par une nouvelle pièce.
3. FAC garantit un fonctionnement correct du système uniquement si des pièces de recharge d'origine sont utilisées.

Attention: FAC décline toute responsabilité en cas d'installation incorrecte ou d'utilisation d'accessoires/pièces de rechange non originaux et inadaptés.

Les accessoires qui composent les kits ainsi que la proposition d'installation se réfèrent à un exemple standard. Une installation non conforme à la procédure indiquée ou la non-exécution des opérations d'entretien correctes, peuvent provoquer un dysfonctionnement du portail, en mettant en danger la sécurité des choses se trouvant à proximité. Vérifier que les accessoires soient appropriés à l'ouvrage spécifique et l'équiper de tous les dispositifs de sécurité prévus par la réglementation en vigueur.

Pour des informations supplémentaires vous pouvez écrire à info@facsl.com

1. Nach Abschluss der Installation die Funktionsprüfungen vornehmen. Regelmäßig kontrollieren, ob das System einwandfrei arbeitet, keine gelockerten Stellen hat und gut geschmiert ist (empfohlen alle drei Monate, spätestens alle 20.000 Vorgänge). Bei Bedarf die Schrauben anziehen und schmieren.
2. Bei Fehlfunktionen, die durch Verschleiß oder versehentliche Stöße bedingt sind, ist sicherzustellen, dass alle Komponenten, die das Tor tragen und bewegen, intakt sind. Bei Bedarf sind solche Komponenten zu ersetzen..
3. FAC übernimmt die Gewährleistung für den einwandfreien Betrieb des Systems ausschließlich dann, wenn Originalersatzteile benutzt werden.

Achtung: Die Firma FAC übernimmt keine Haftung für den Fall einer fehlerhaften Installation oder die Verwendung von Zubehör, Komponenten und Ersatzteilen, die nicht original und nicht für das jeweilige Werk geeignet sind.

Das im Kit enthaltene Zubehör und die vorgeschlagene Anlage beziehen sich auf ein Standardbeispiel. Eine Installation, die nicht der dargestellten Prozedur entspricht oder die Unterlassung der korrekten Wartung können Fehlfunktionen verursachen sowie die Sicherheit von in der Nähe befindlichen Personen und Sachwerten beeinträchtigen. Prüfen Sie, ob das Zubehör für die spezifische Anlage geeignet ist. Diese ist mit den notwendigen und vorschriftsmäßigen Sicherheitsvorrichtungen auszustatten.

Weitere Informationen erhalten Sie unter: info@facsl.com

KIT BI-FOLDING 180° BI-FOLDING 180° KIT

Kit accesorios de acero galvanizado, con bisagras de aluminio, para la realización de una puerta Bi-folding con hojas de libro. El sistema de 180° ha hecho suyas todas las características del sistema Bi-folding, equipándose con un brazo específico y goznes especiales que permiten su movimiento hasta 180°. Los goznes y las bisagras se han diseñado específicamente y garantizan una realización de solidez excepcional, asociada con un movimiento preciso, sin necesidad de rieles en el suelo. Además, las hojas plegables permiten reducir al mínimo la ocupación de espacio durante las fases de apertura y de cierre. Este sistema es perfecto para aplicaciones de uso residencial y/o comercial, manteniendo siempre una atención especial a las necesidades de protección y seguridad.

Galvanized steel accessory kit, with aluminum hinges, for the construction of a Bi-folding gate with folding leaves. The 180° system has made all the features of the Bi-folding system its own, being equipped with a special arm and special hinges that allow it to rotate up to 180°. The hinges were specifically designed and ensure exceptionally solid construction, combined with precise movement, without the need of ground rails.

In addition, the folding leaves allow to reduce the footprint to the minimum during the opening and closing phase. Our Bi-folding 180° is designed for both industrial and commercial use, with a particular attention to the protection and security needs.



KC7201.160

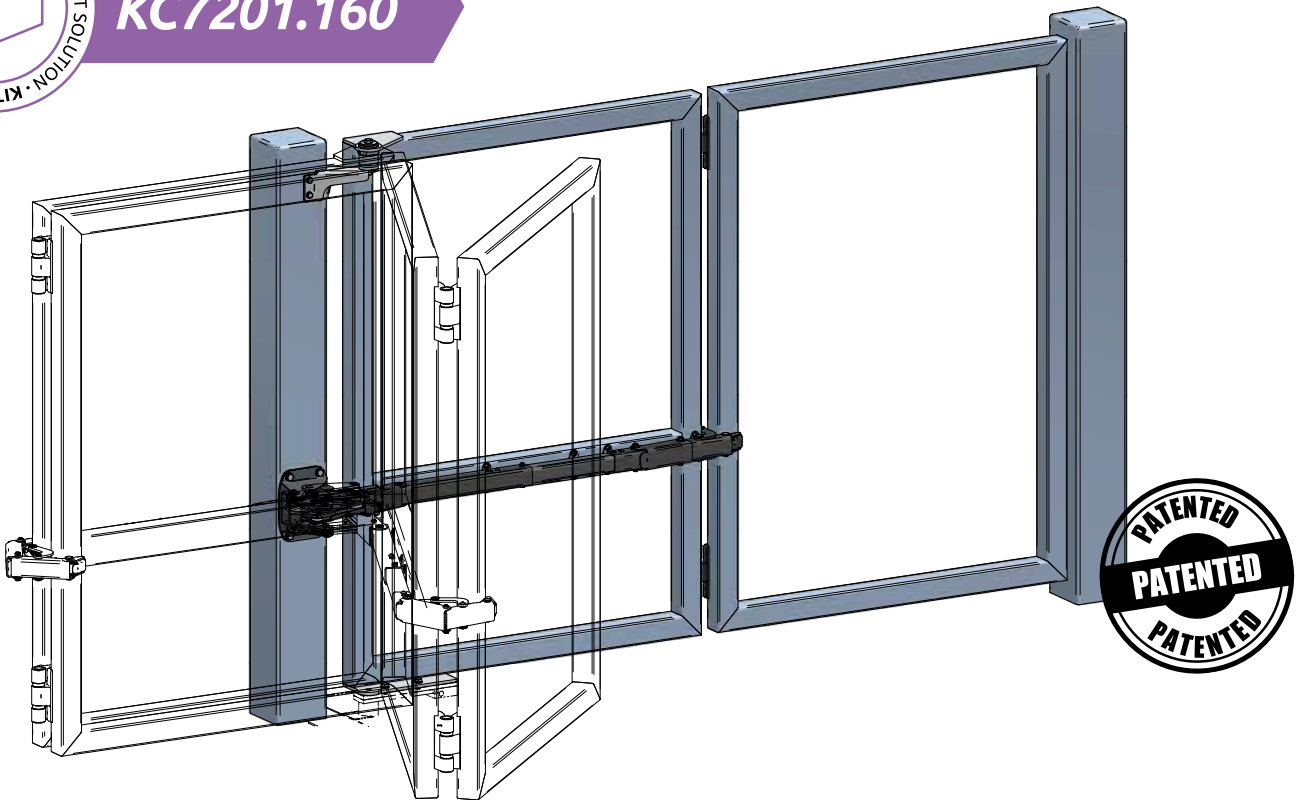

1 kit

Para puerta simple
Single leaf

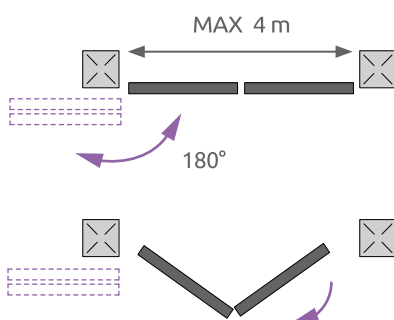





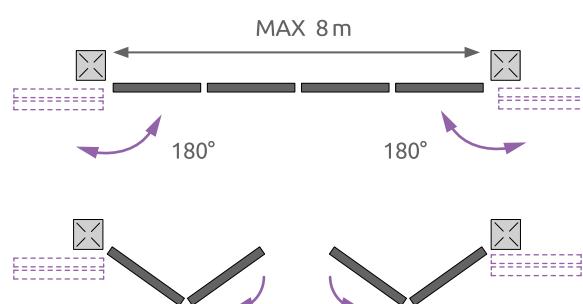



2 kit

Para puerta doble
Double leaf





LISTA DE COMPONENTES
COMPONENTS

<p>x1</p> 	<p>x1</p> 	<p>x1</p> 
<p>VC7201.060</p>	<p>VC7202.060</p>	<p>VC7203.060</p>
<p>x1</p> 	<p>x1</p> 	<p>x2</p> 
<p>VC7205.060</p>	<p>VC7204.060</p>	<p>VL4500</p>
<p>x1</p> 	<p>x1</p> 	<p>x1</p>  <p>* solo per montaggio provvisorio, vedi istruzioni a seguire * sólo para montaje provisional. Ver las instrucciones a continuación.</p>
<p>VC7105.060</p>	<p>VA5401</p>	<p>Bisagra inferior/bottom hinge</p>

ARTÍCULOS RELACIONADOS
RELATED ARTICLES



VC9101
VC9111



VC5101
VC5102
VC5103



Conéctese a nuestra pagina web para conocer
los diferentes tipos y tamaños disponibles
Click on our website for other related items



TABLA DE DIMENSIONES
SIZES CHART

A min-max (m)	B min (mm)	C (mm)	D min (mm)	E min (mm)	M max (mm)	Q (mm)	A/H max	H max (m)
2,2 - 4	70	50	60	80	800	60	3	2,5

APERTURA A (m) OPENING A (m)	L (m) con/with B=0,07 m	Peso max S2 (kg) Max weight S2 (kg)
2,2	~ 1,04	125
2,6	~ 1,24	125
3	~ 1,44	125
3,5	~ 1,69	120
4	~ 1,94	105

EJEMPLO DE MEDIDAS FUERA DE LA TABLA
EXAMPLE OF OUT-OF-TABLE MEASUREMENTS

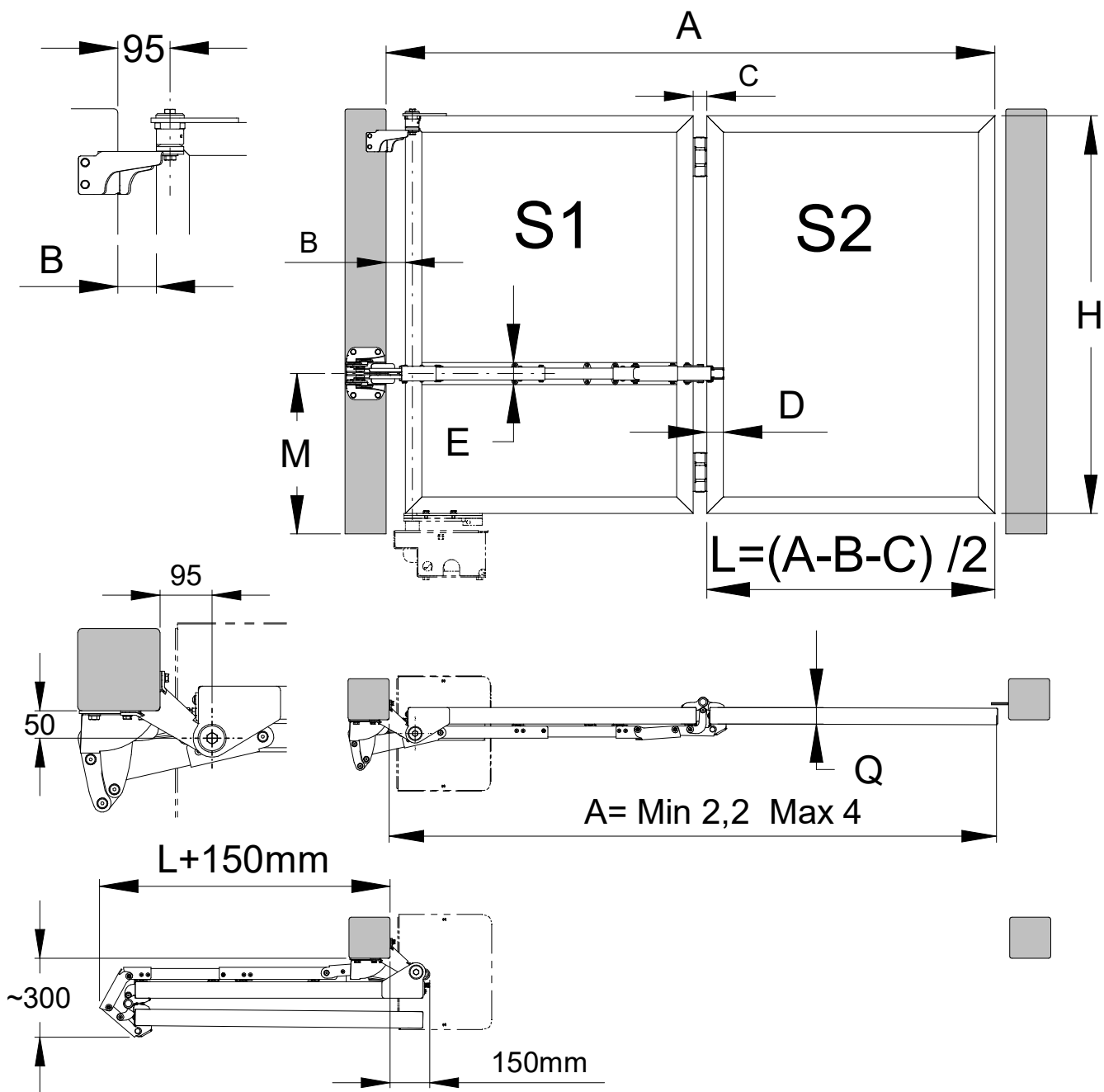
A = 3,6 m
 B = 70 mm (como en la tabla superior / as per above table)
 C = 50 mm (como en la tabla superior / as per above table)
 L = (A-B-C)/2
 $L = (3,6 - 0,07 - 0,05) / 2$
 L = 3,48/2
 L = 1,74 m

Datos calculados con A/H = 2
 Data calculated with A/H = 2



PESO MÁXIMO S2 EN RELACION CON L
MAX WEIGHT S2 IN RELATION TO L

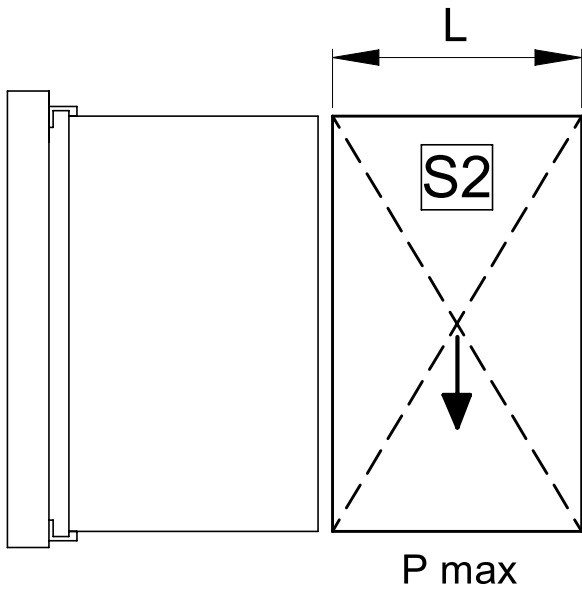

Peso de la hoja en relación con la longitud
Leaf weight in relation to the length

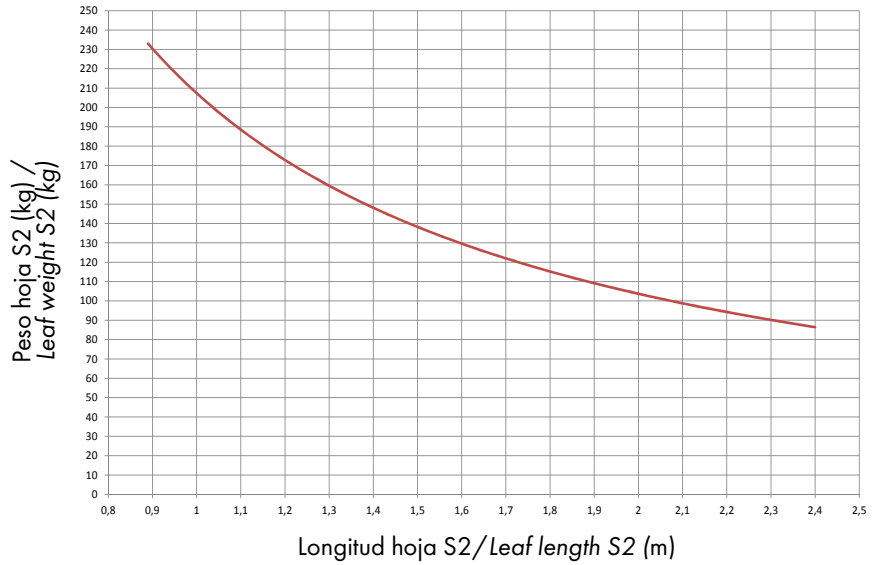

CAPACIDAD DE CARGA DE LOS PERNIOS EN RELACIÓN A A/H
HINGES WEIGHT CAPACITY IN RELATION TO A/H

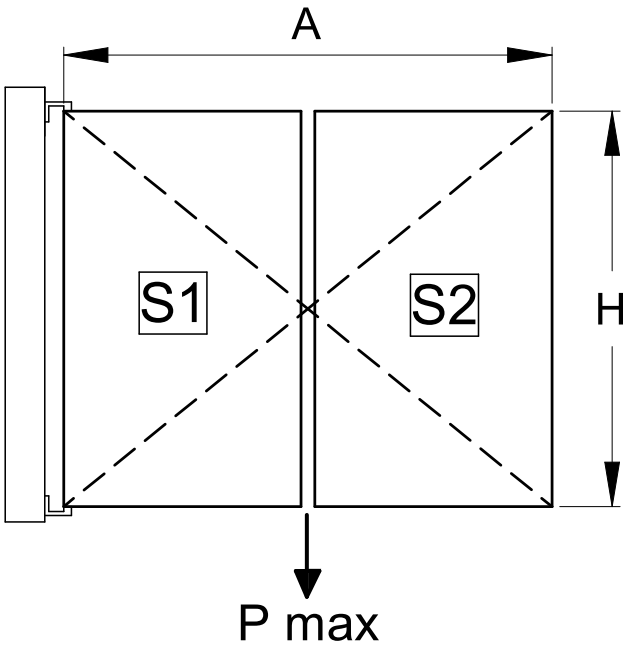

A/H MAX = 3

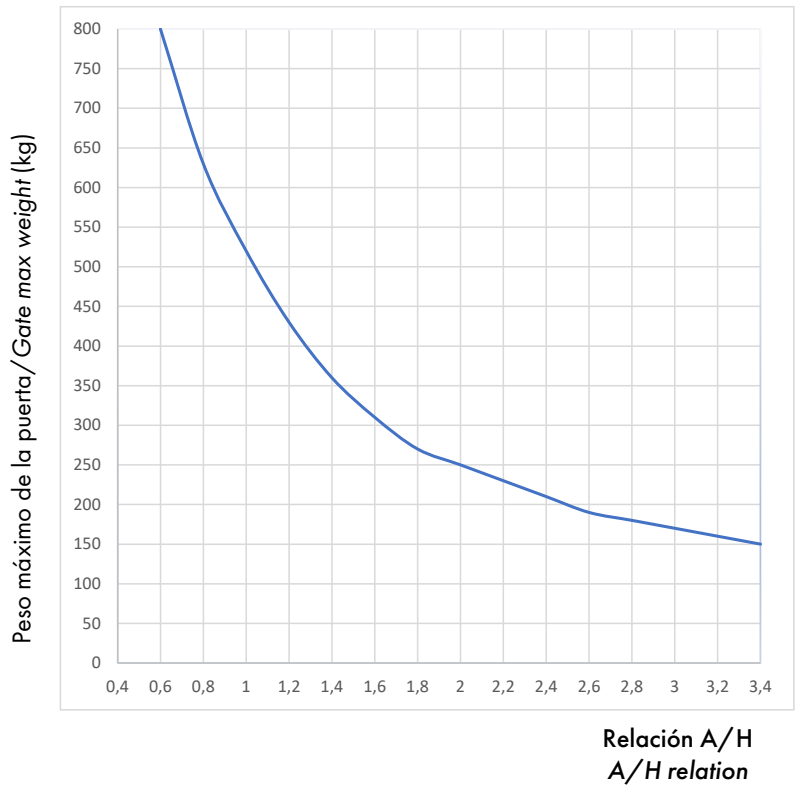

El punto de cruce entre el peso y la relación A/H debe estar por debajo de la curva.
The crossing point between weight and A/H relation must be under the curve of the kit.



INFORMACIÓN TECNICA
TECHNICAL INFO

1. Bi-folding 180° necesita un motor enterrado, con movimiento mínimo de 180°. Velocidad de rotación 180° en mínimo 60 segundos. Prever arranques y paradas lentos y velocidad bajas para evitar efectos elásticos entre las hojas y disfunciones.

1. Bi-folding 180° need underground motor, with minimum movement of 180°. Rotation speed of 180° minimum 60 seconds. For motorized gates provide slow starting points, soft stops and suitable speed in order to avoid elastic effects between the leaves and malfunctions.

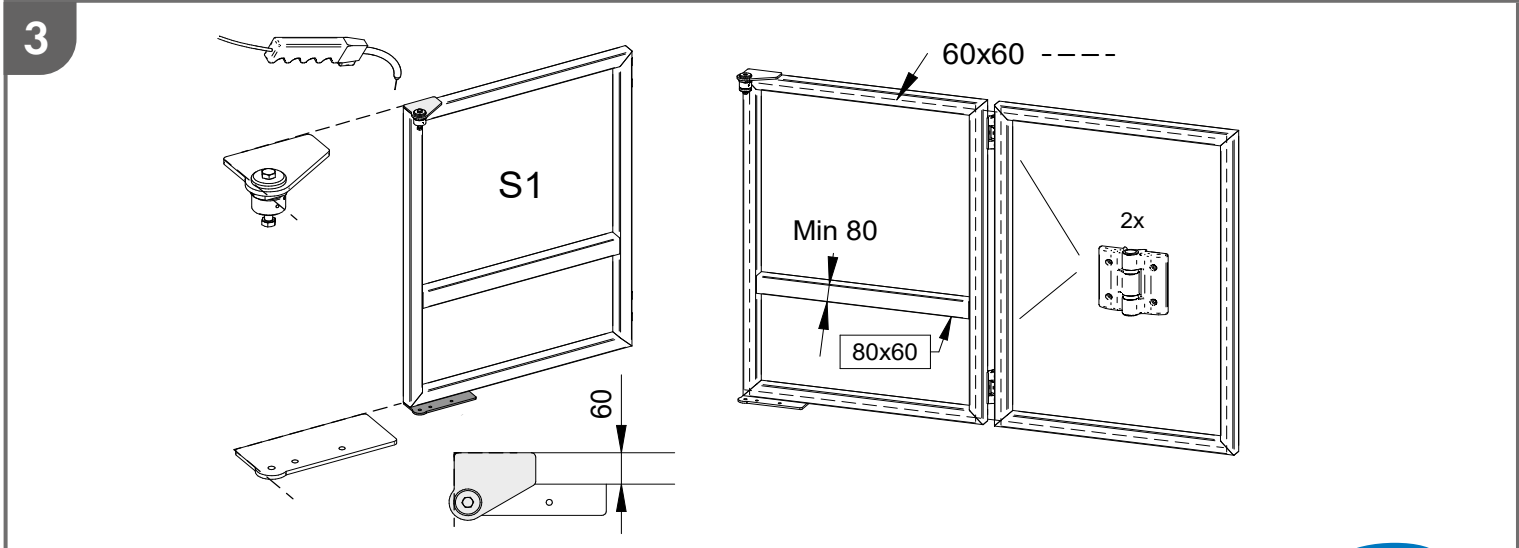
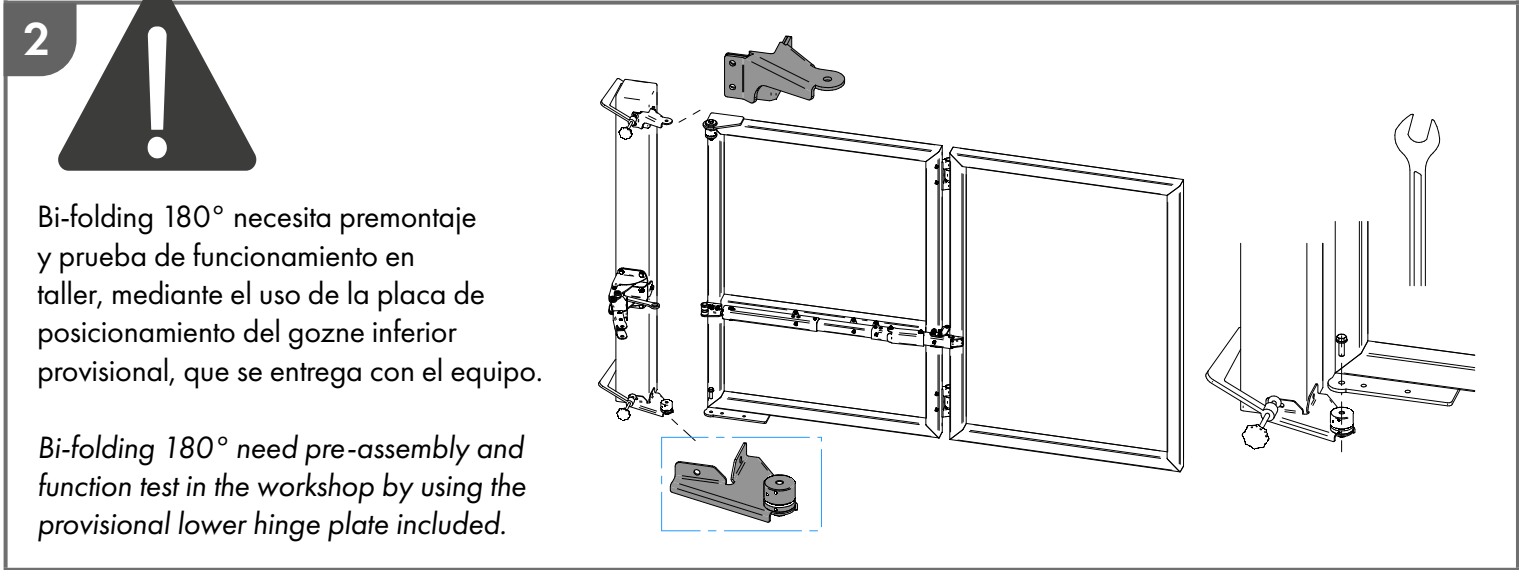
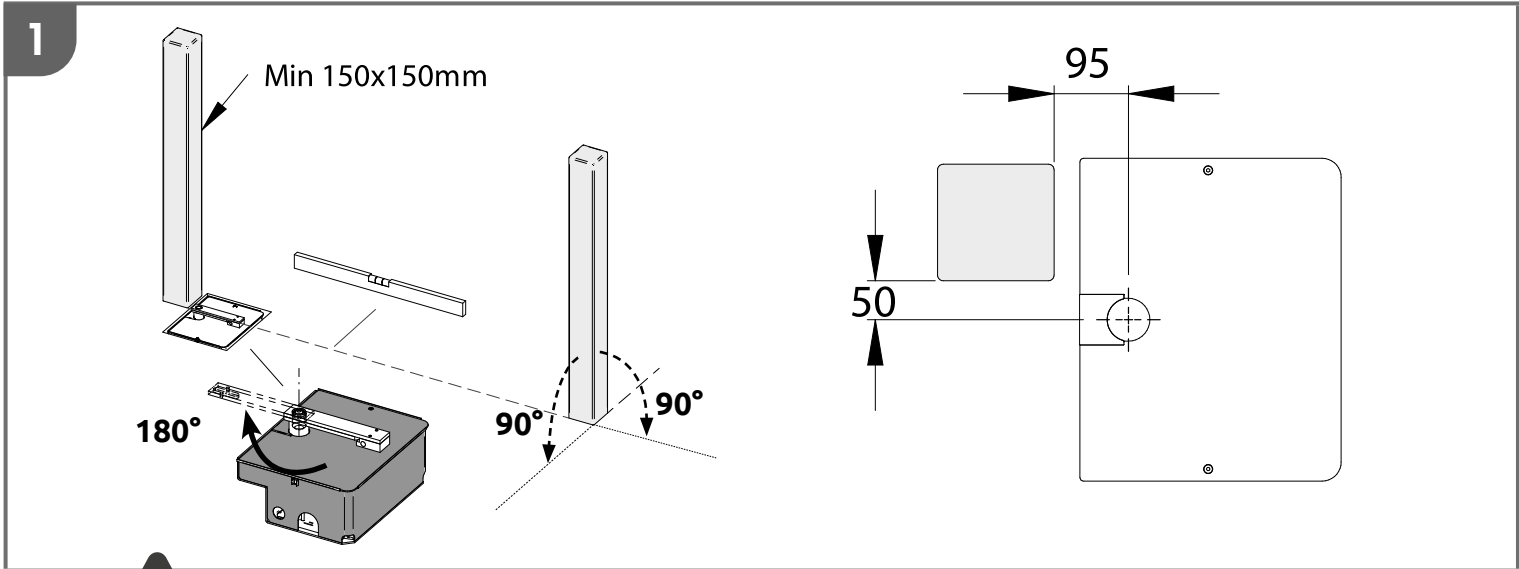



4

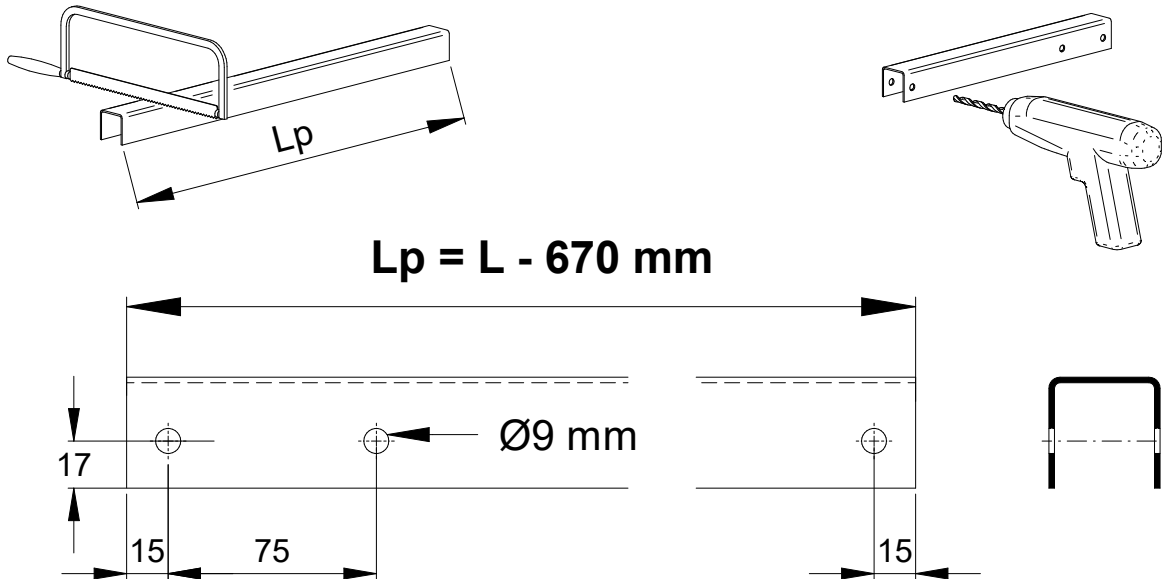

5

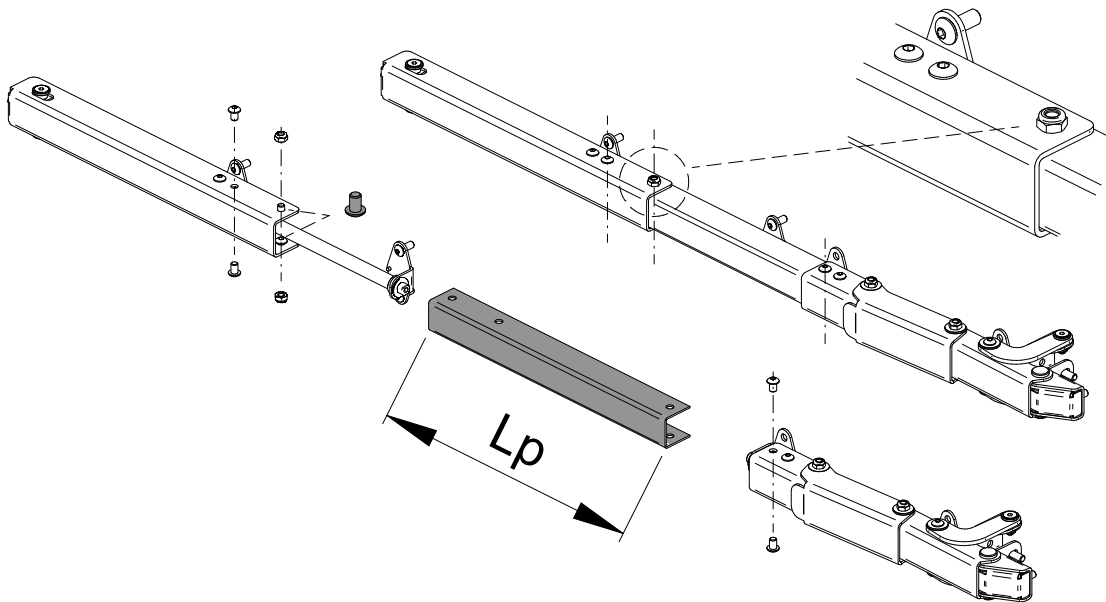

6

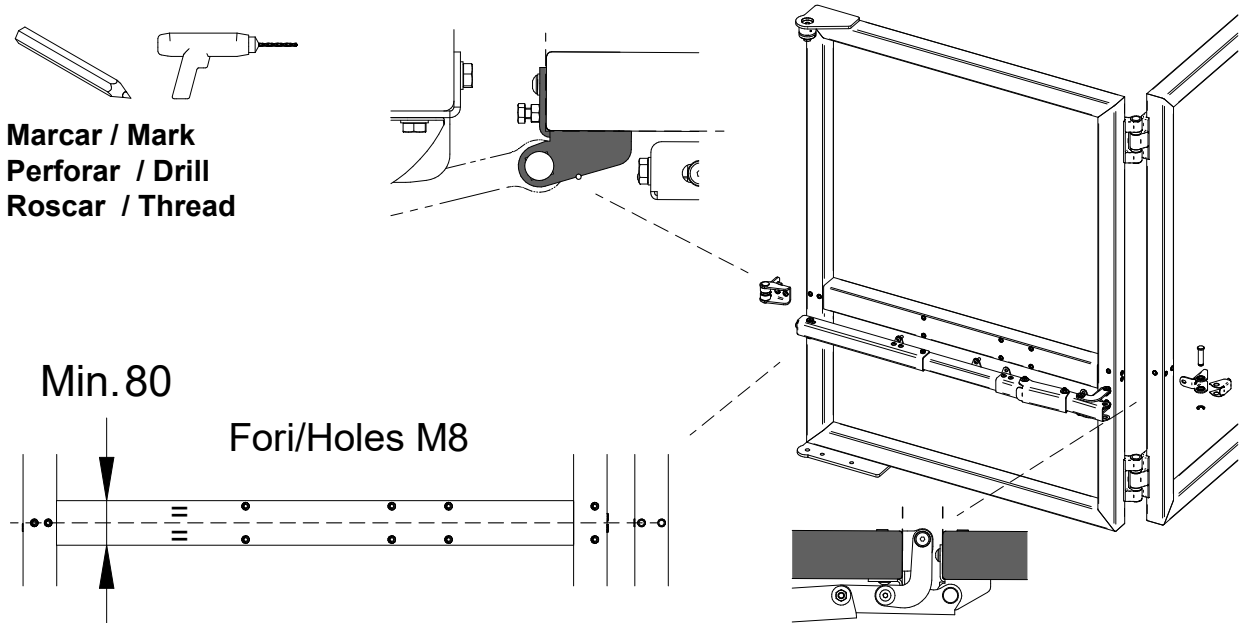



7

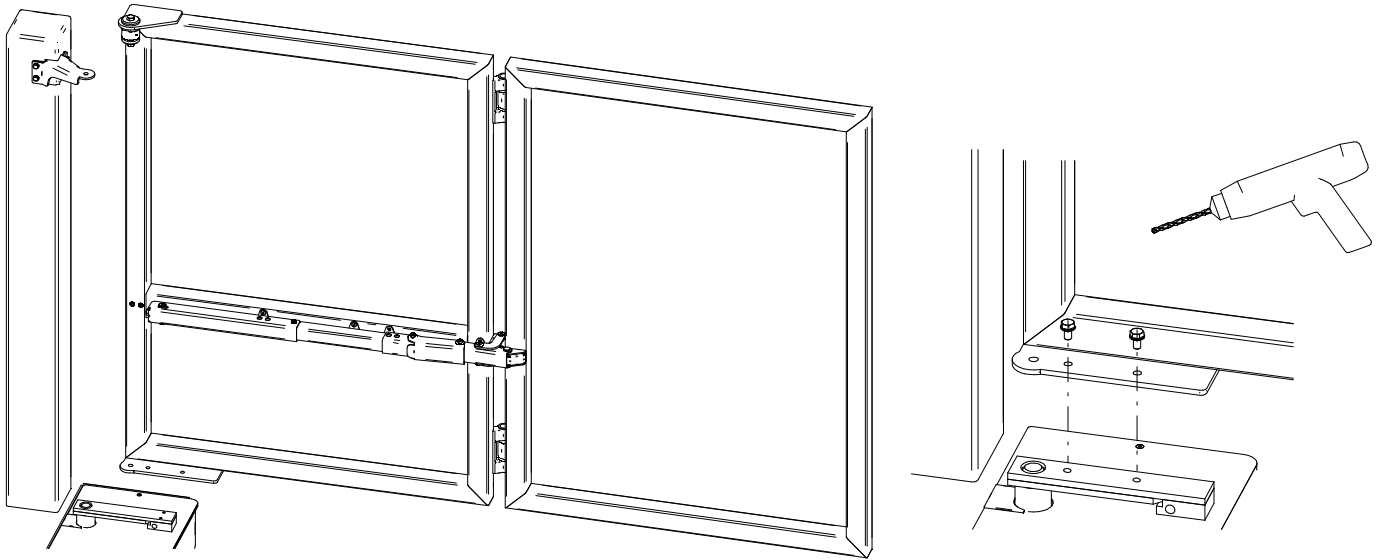

8

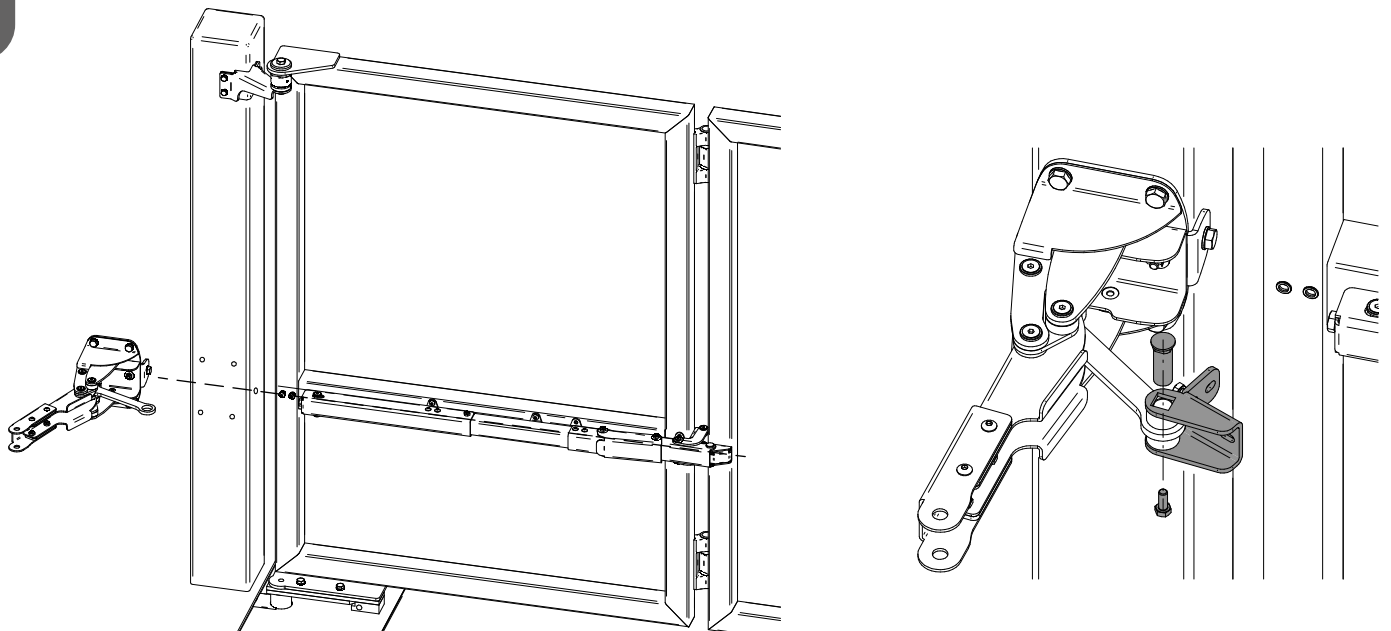

9

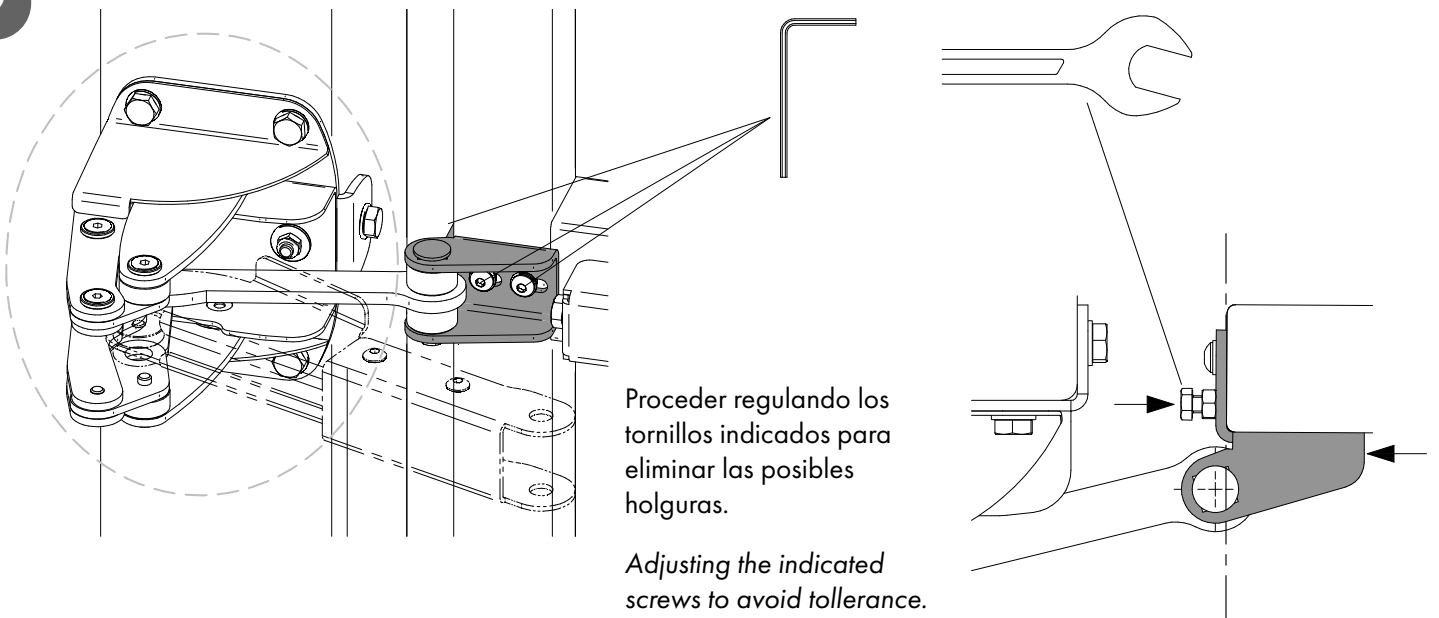

Proceder regulando los tornillos indicados para eliminar las posibles holguras.

Adjusting the indicated screws to avoid tolerance.



10

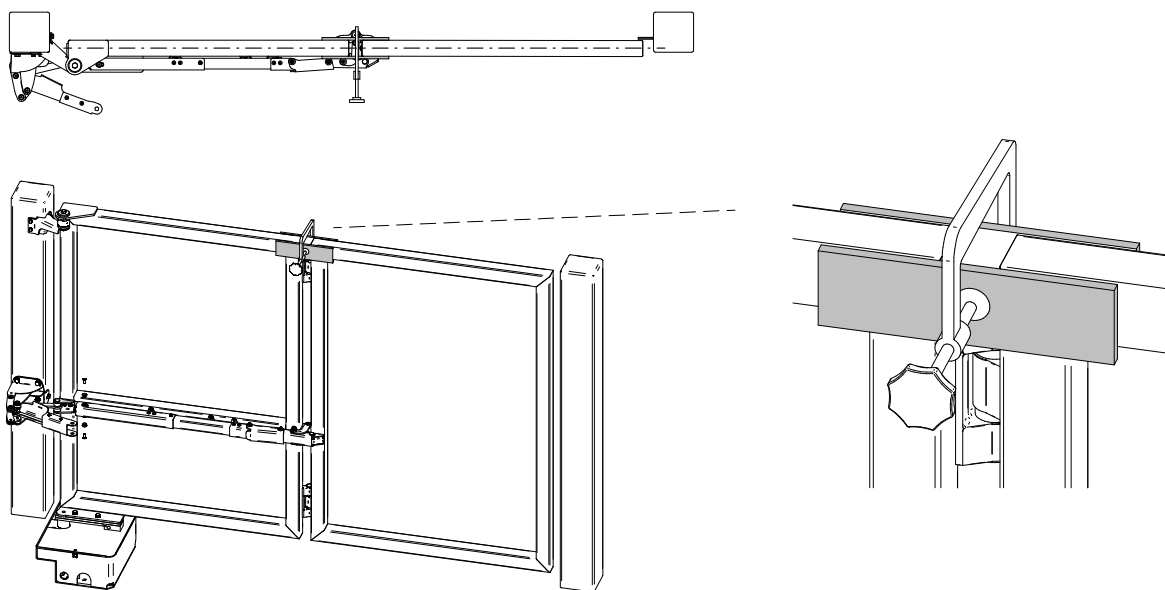

11

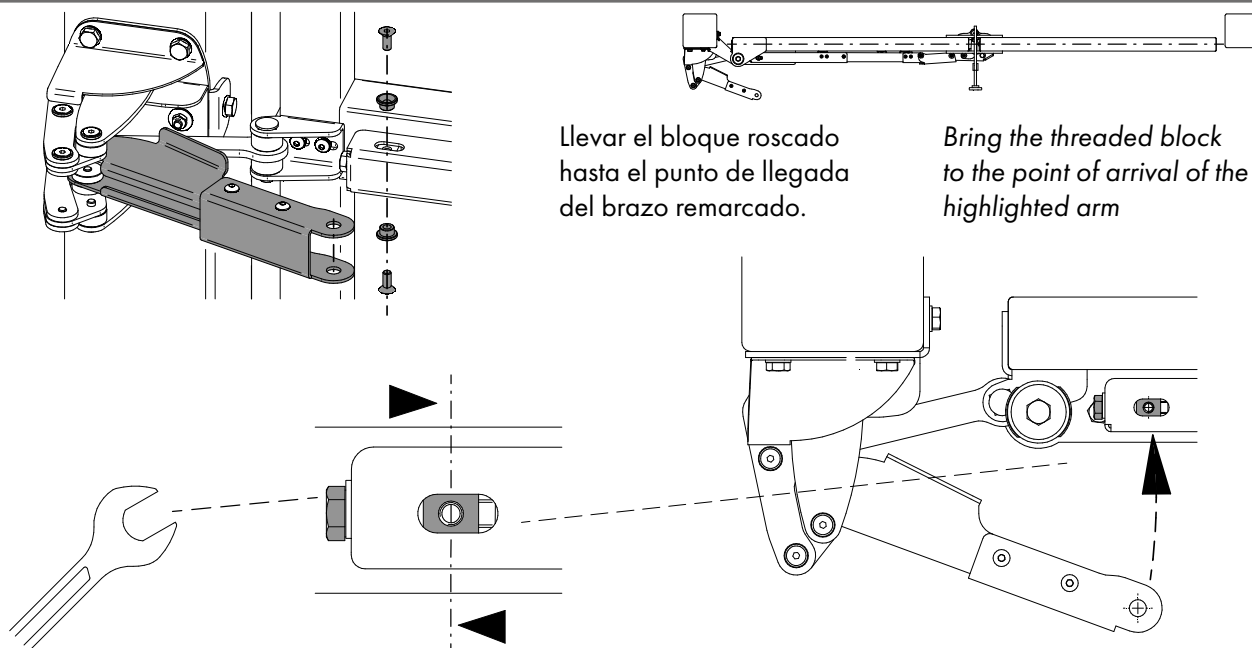

12

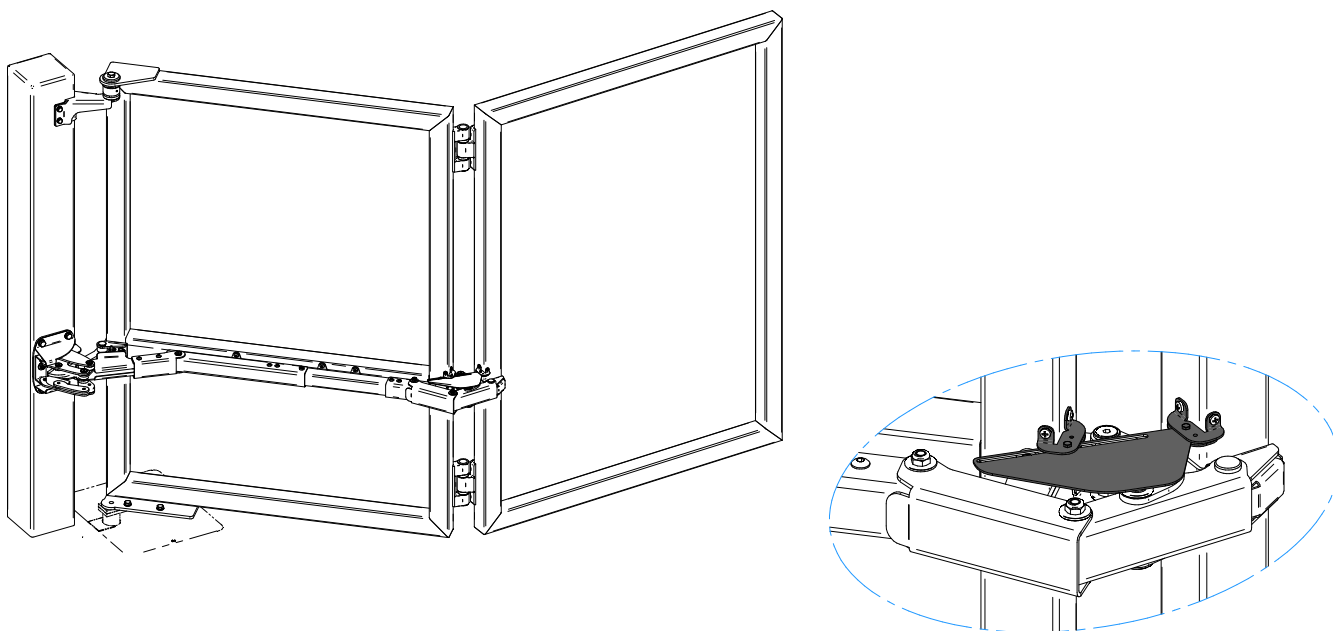



13

R



**CARTER DE SEGURIDAD
SAFETY CARTER**

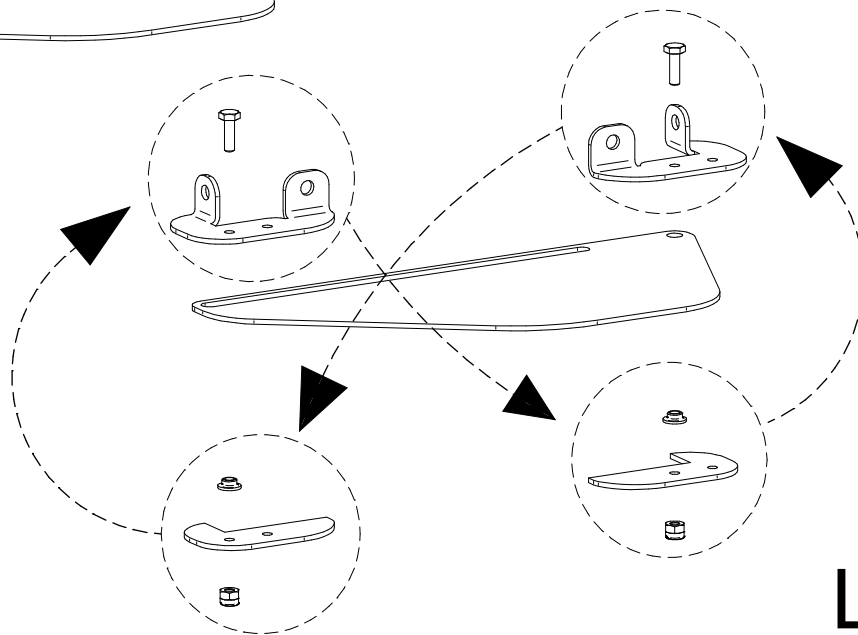
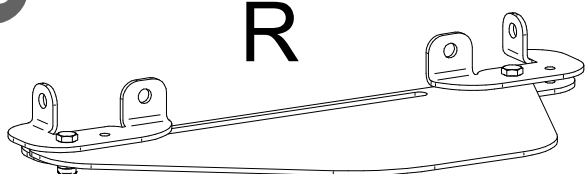

L

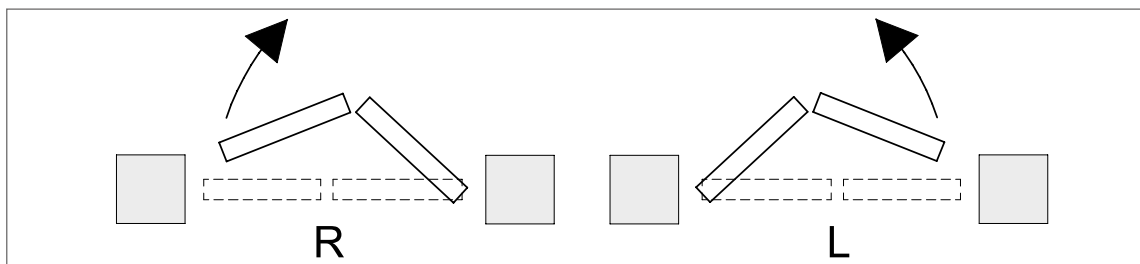
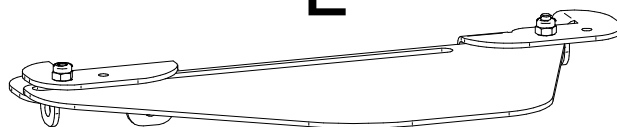



MANTENIMIENTO MAINTENANCE

1. Inspeccione manualmente el funcionamiento al final de la instalación; periódicamente revise que el sistema funciona correctamente, que está bien lubricado que no hay ningún aflojamiento (sugerimos una revisión completa cada 3 meses o después de 8000 ciclos).
2. En caso de funcionamiento incorrecto debido al desgaste o a impactos accidentales, asegúrese que todos los componentes están aptos para soportar la puerta y que su conservación está intacta. Si fuera necesario, proceda con la sustitución.
3. FAC asegura el correcto funcionamiento del sistema solo si se usan componentes originales.

Atención: FAC no asume ninguna responsabilidad en caso de instalación o uso equivocado de accesorios/ componentes/repuestos no originales y no idóneos para la obra específica.

El Kit incluye accesorios y la propuesta de instalación hace referencia a un ejemplo estándar. Una Instalación que no esté de acuerdo con el procedimiento ilustrado y la omisión del correcto mantenimiento podrían comprometer bienes cercanos y la seguridad de las personas. Asegúrese de que todos los accesorios se adaptan a su trabajo específico y asegúrese del uso de los dispositivos de seguridad previstos por las regulaciones vigentes.

Para más información: info@facsrl.com

1. Perform all functioning inspections manually at the end of the installation; periodically check that the system is functioning, that it is well lubricated and does not have any loosening (we suggest a full examination every 3 months or maximum 20.000 cycles).
2. In case of malfunctions due to wear or accidental impacts, make sure that all components apt to support the gate and its movement are intact. If necessary, proceed with substitution.
3. FAC ensures the system correct functioning only using original spare parts.

Attention: FAC does not assume any responsibility in the event of incorrect installation or use of non-original and unsuitable accessories/spare parts.

The kit included accessories and the proposed installation make reference to a standard example. An installation not in accordance with the illustrated procedure and the omission of the correct maintenance might compromise nearby things and people's security. Make sure that all accessories suit the specific work and make sure to use the necessary safety devices provided by current regulations.

For more information: info@facsrl.com